

# **Dictionary of American Naval Aviation Squadrons**

Volume I

## ***The History of VA, VAH, VAK, VAL, VAP and VFA Squadrons***

Roy A. Grossnick



Naval Historical Center  
Department of the Navy  
Washington, D.C., 1995

**Library of Congress Cataloging-in-Publication Data**

Grossnick, Roy A.

Dictionary of American Naval Aviation Squadrons / by Roy A. Grossnick.

p. cm.

Contents: v. 1. The history of VA, VAH, VAK, VAL, VAP, and VFA squadrons

ISBN 0-945274-29-7 (v. 1)

1. United States. Navy—Aviation—History. 2. Airplanes, Military—United States—History. I. Naval Historical Center (U.S.) II. Title. III. Title: American naval aviation squadrons.

VG93.G76 1995

359.9'434'0973—dc20

94-35647

# ***Secretary of the Navy's Advisory Committee on Naval History***

William D. Wilkinson, Chairman  
CAPT Edward L. Beach, USN (Retired)  
David R. Bender  
John C. Dann  
RADM Russell W. Gorman, USNR (Retired)  
Richard L. Joutras  
VADM William P. Lawrence, USN (Retired)  
Vera D. Mann  
Ambassador J. William Middendorf II  
VADM Gerald E. Miller, USN (Retired)  
Clark G. Reynolds  
Betty M. Unterberger

## *About the Author*

**R**OY A. GROSSNICK is currently a historian and head of the Naval Aviation History Office, a branch of the Naval Historical Center. He graduated from Wisconsin State University, Stevens Point, where he earned a Bachelor of Science in history in 1970. In 1972, Mr. Grossnick completed a Master of Arts in history at the University of Wisconsin, Madison. He served in the Navy on active duty for ten years. Following his separation from military service, Mr. Grossnick worked at the Smithsonian's National Air and Space Museum. In 1980, he assumed the historian position in the Naval Aviation History Office. He has written numerous articles for *Naval Aviation News* magazine and was the author of the monograph *Kite Balloons to Airships . . . the Navy's Lighter-than-Air Experience*, Volume 4 in a commemorative collection published in 1986 to mark the 75th anniversary of naval aviation.

Mr. Grossnick resides in Chevy Chase, Maryland, with his wife, Mary, and daughter Maki.



*Mr. Grossnick resides in Chevy Chase, Maryland, with his wife, Mary, and daughter Maki.*

# ***Contents***

Foreword / ix

Preface / xi

Acknowledgments / xiii

## **Chapter 1**

The Evolution of Aircraft Class and Squadron  
Designation Systems / 1

## **Chapter 2**

Attack Squadron Histories (VA) / 17  
*VA-1E to VA-873*

## **Chapter 3**

Heavy Attack Squadron Histories (VAH) / 295  
*VAH-8 to VAH-123*

## **Chapter 4**

Tactical Aerial Refueling Squadron Histories (VAK) / 303  
*VAK-208 to VAK-308*

## **Chapter 5**

Light Attack Squadron History (VAL) / 307  
*VAL-4*

## **Chapter 6**

Heavy Photographic Squadron Histories (VAP) / 309  
*VAP-61 to VAP-62*

## **Chapter 7**

Strike Fighter Squadron Histories (VFA) / 317  
*VFA-15 to VFA-305*

	<i>Title</i>	<i>Page</i>
Appendix 1	Aircraft Data—Technical Information and Drawings	443
Appendix 2	Aircraft Carrier Listing for CV, CVB, CVA, CVAN, CVN, CVL, and CVE Designations	517
Appendix 3	Carrier Deployments by Year	521
Appendix 4	U.S. Navy Squadron Designations and Abbreviations	537
Appendix 5	How to Trace Squadron Lineage	541
Appendix 6	Lineage Listing for VA, VA(AW), VAH, VA(HM), VAK, VAL, VAP, and VFA Designated Squadrons	543
Appendix 7	Types of Aircraft Listed in Squadron Histories	551
	Glossary of Abbreviations and Terms	553
	Bibliography	557
	Index of Squadron Histories and Aircraft Data	561

# Foreword

**G**REAT CREDIT IS DUE TO ROY GROSSNICK and his expert staff in the Naval Historical Center's Aviation History Branch for initiating a new publication series entitled the *Dictionary of American Naval Aviation Squadrons*. The first volume of that series, which we are now publishing, includes approximately 140 histories and other data covering every squadron in the attack (VA) and strike fighter (VFA) communities from the time the first of these commands (VA-35) was established in 1934. This publication may be compared to the *Dictionary of American Naval Fighting Ships*, a nine-volume compilation of individual ship histories published by the Naval Historical Center between 1959 and 1991. Now, at long last, a basic reference work is under preparation that provides similar data for aviation commands.

Subsequent volumes in this series will cover other components of naval aviation. At the present time, the Aviation History Branch is preparing a follow-on volume containing histories of all patrol squadrons of the U.S. Navy. This task is in addition to the many other duties that office handles, including the writing of arti-

cles for *Naval Aviation News* and responding to an increasingly heavy load of official and unofficial requests for information on all aspects of aviation history.

History is a useful subject for the Navy for several reasons. Insofar as it represents the sum total of the Navy's experience, it is an essential subject for study by naval professionals. History also is a means of giving an account to the American people of the activities of their Navy. Finally, since history allows naval personnel to learn about the origins, achievements, and traditions of their commands and of the Navy as a whole, it is a powerful means to promote naval morale. The Navy's historians publish the first volume with all of these purposes in mind. We hope this volume will be of interest and use to the active-duty Navy and to many other individuals interested in this nation's rich naval heritage.

Dean C. Allard  
Director of Naval History

# Preface

**T**HE *DICTIONARY OF AMERICAN NAVAL AVIATION SQUADRONS*, the first of a multivolume series, provides a brief history, by community, of every squadron the Navy has established since the evolution of the squadron concept in the post-World War I era. The information and format selected to tell the story of each squadron was developed from a pattern of common reference questions. The nature of the squadron data lends itself to a variety of formats for most entries in the squadron histories instead of a straight narrative style. The dictionary, written primarily for use as a reference work, states concise facts about each squadron that provide a better understanding of the contributions made by naval aviation squadrons in service to their country.

Naval aviation is primarily a twentieth century development and has become an important element of U.S. sea power. It is part of the technological revolution that has been the hallmark of the twentieth century. The aircraft, weapons systems and associated technical equipment, combined with the men and women assigned to the squadrons, are instrumental to its success.

Each squadron history begins with a lineage section that starts with the date of establishment. It also includes any redesignations and disestablishment date if applicable. The squadron's establishment date may be equated to a ship's commissioning and the history for a squadron or ship begins on that date. When a squadron is redesignated, there is no break in the history of that squadron. The history of a squadron covers the period from its establishment to its disestablishment, regardless of how many redesignations it undergoes. Redesignations can cause confusion when tracing the lineage of a squadron. For more information on how to trace squadron lineages, please refer to Appendix 5.

A short description and photograph for all officially approved insignia used by a squadron follows the lineage section. The chronology narrates the squadron's important operational events and developments. The

remaining six sections pertain to the evolutionary history of the squadron and includes listings of home port assignments, commanding officers, aircraft assignments, overseas deployments, air wing assignments and major unit awards.

This first volume covers the attack and strike fighter communities and includes VA (attack squadron), VAH (heavy attack squadron), VAK (tactical aerial refueling squadron), VAL (light attack squadron), VAP (heavy photographic squadron) and VFA (strike fighter squadron). Although VAK and VAP did not have a primary mission of offensive and defensive air-to-surface operations, they are included here because these squadrons operated attack-designated planes, such as the AJ-2 and the A-3 and its derivatives. The squadron histories in this volume cover only those squadrons that are currently designated VA or VFA or those that had the VA, VAH, VAK, VAL, VAP and VFA designations when they were disestablished. Any attack squadron redesignated VF, VS, RVAH, VAQ or VAW that did not revert back to VA is not in this volume. The lineage listing in Appendix 6 provides a cross reference list for all squadrons that may have had the VA, VA(AW), VAH, VA(HM), VAK, VAL, VAP and VFA designation.

Reserve squadron histories begin in 1970 following the reorganization of the Naval Air Reserve Force. Prior to that time reserve air squadrons were not permanently assigned aircraft. During weekend drills they used aircraft from their local naval air station. This pre-1970 organizational system, combined with the fact that these squadrons provided no permanent historical records, makes it difficult to trace its activities. Hence, histories on reserve squadrons prior to 1970 cover only those squadrons called to active duty and assigned their own aircraft.

Histories for active squadrons cover the period from establishment up through 1990, an arbitrary cutoff date. If a squadron was redesignated or disestablished after 1990, its history is updated to its redesignation or disestablishment date.



Most illustrations used in the book are official U.S. Navy photographs unless otherwise identified. If available, a photograph is included for each major type of aircraft operated by a squadron.

Extensive appendices not only provide additional statistical material but also help to clarify or explain the Navy's unique organization and use of acronyms or designations.

When drafting a reference work with such an extensive range of data, it is almost impossible to prevent errors. An exhaustive effort was made to check the

compilation of material presented in this book. When different sets of records or sources provided conflicting dates, I attempted to select the most accurate one based on my research. In some cases only a specific year could be determined. As the writer and major compiler of the data for this volume, I accept full responsibility for any mistakes or errors of fact or misinterpretations that may have occurred in the book, and I welcome any corrections.

Roy A. Grossnick

# Acknowledgments

I CONCEIVED THIS BOOK AFTER eight years of working in the Naval Aviation History Office. A common request received by the office was for a complete history of a particular squadron. Realizing the need for a history of all naval aviation squadrons prompted the development of a format that would meet the requirements posed by the Navy and most people requesting information on a squadron. Using the *Dictionary of American Fighting Ships* as an example of an excellent primary reference source, I patterned my approach along lines similar to that series.

I am very grateful for the guidance and support provided by many individuals and organizations that were instrumental in making this book possible. The initial support I received from Captain Steven U. Ramsdell, USN (Ret.), former Director, Naval Aviation History and Publications Division, in getting this project off the ground was one of the keys to the successful completion of the book. He provided valuable comments in his reviews of the draft histories. His successors, Commander Stephen R. Silverio, USN (Ret.) and Commander Michael S. Lipari, continued in his footsteps, providing review recommendations as well as support for the project.

The personnel in the Naval Aviation History Office, Ms. Gwen Rich, Ms. Judith Walters and Mr. Steven Hill, were my prime supporters in writing the book. Special thanks go to Mr. John M. Elliott, retired historian from the office, for his recommendations, and providing the aircraft line drawings for Appendix 1, as well as other assistance in getting the book ready for publication. The staff from the *Naval Aviation News* Branch, filled the editorial role. The manuscript was reviewed several times by Mrs. Sandy Russell and Ms. Joan A. Frasher. Mr. Charles C. Cooney provided design support for the squadron format, as well as extensive photographic support.

I would also like to recognize Naval Historical Center offices that made their records available. First, and foremost, was the Operational Archives Branch. Mrs. Kathleen M. Lloyd and members of her Research and Reference Section, as well as Mrs. Judith W. Short, were always willing to make that extra effort to find the documents I needed for the book. Mr. John C. Reilly and

the Ships' Histories Branch was always there to provide documentation regarding a particular carrier. The staff of the Navy Department Library was particularly helpful when I reviewed their collection of cruise books. The Photographic Section of the Curator Branch, particularly Mr. Edwin C. Finney, Jr., was always responsive to my needs for particular aircraft photographs. The services provided by Ms. Sandra J. Doyle, the Naval Historical Center's senior editor, are also appreciated.

The advice, information and comments offered by personnel outside the Naval Historical Center warrant special attention. Mr. Harold Andrews, Captain Rosario (Zip) Rausa, USN (Ret.), and Captain Kenneth L. Coskey, USN (Ret.), reviewed sections of the manuscript and provided valuable recommendations. A very special thank you goes to Vice Admiral William P. Lawrence, USN (Ret.), a member of the Secretary of the Navy's Advisory Committee on Naval History, for reviewing the complete manuscript. Mr. Robert Lawson, past editor of *The Hook* magazine, has lent encouragement over the past six years and provided many photographs from his collection. Mr. Duane Kasulka, as well as many other individuals, also contributed photographs from their collections.

Dr. William J. Armstrong, historian for the Naval Air Systems Command, compiled and drafted the manuscript on aircraft data for Appendix 1. When writing the history of naval aviation, it is imperative that the technical aspects are included with the operational history. His contributions in Appendix 1 will help to amplify and clarify information regarding the specific aircraft operated by the Navy's aviation squadrons.

I would like to express my thanks to my wife, Mary, and daughter, Maki, for helping to assemble the book during its last stages before publication. I owe a debt of gratitude to Mr. John Grier, a design and typesetting specialist from the Government Printing Office, for his efforts in getting the book ready for the printer. For those I have not mentioned by name, let me say that your contributions are appreciated and are not forgotten.

Roy A. Grossnick

# ***The Evolution of Aircraft Class and Squadron Designation Systems***

---

**N**AVAL AVIATION HAS BECOME the forward element of America's ability to project its influence, at short notice, any place in the world. It is a product of the 20th century and reflects the massive technological developments and changes that have characterized this century. One reason for naval aviation's success has been its ability to change with the times and keep pace with innovations in technology. This, in turn, has made aviation squadrons a flexible tool that can adapt quickly to new missions or requirements.

This chapter will provide the background necessary to help understand the history and evolution of naval aviation squadron designations. The Navy has used over one hundred different squadron designations since the inception of the squadron concept. This figure does not include Marine Corps squadron designations. To further complicate the Navy's squadron designation system, many of the squadron abbreviations, such as VT, have had different mission functions during different time frames. As an example, the VT designation was used as an abbreviation for a Torpedo Squadron from the early 1920s and lasting until 15 November 1946 when the designation VT (Torpedo Squadron) was abolished. Then, on 1 May 1960, the use of the VT designation was reinstated. However, this time the meaning and mission for VT was assigned as training and stood for Training Squadron (VT). This is just one example of the many changes that have occurred in the squadron designation system.

In order to more fully understand squadron designations, it is important to know the factors that played a role in developing the different missions that squadrons have been called upon to perform. Technological changes affecting aircraft capabilities have resulted in corresponding changes in the operational capabilities and techniques used by aviation squadrons. In the early period of naval aviation a system was developed to designate an aircraft's mission. Different aircraft class designations evolved for the various types of missions performed by naval aircraft. This became known as the Aircraft Class Designation System. The Squadron Designation System and the Aircraft Class Designation System are separate systems.

Yet, there is an inherent parallel relationship between the two systems whereby changes in the Aircraft Class Designation System have an effect on the Squadron Designation System. Both systems reflect the technological changes and mission developments in aircraft. Numerous changes have been made to both systems since the inception of naval aviation in 1911.

With the evolution of the squadron concept, a Squadron Designation System was developed to identify the specialized missions of various aviation squadrons using different types of aircraft. Since a specific class of aircraft identifies the type of mission performed by the squadron operating a particular aircraft class, an inherent parallel relationship occurs between the Aircraft Class Designation System and the Squadron Designation System. As an example, an aircraft designed and built primarily with a mission of dropping torpedoes, such as the World War II TBF Avenger, would normally be assigned to a squadron with a similarly designated mission, such as a Torpedo Squadron (VT). The TBF Avenger aircraft would fall under the VT class in the Aircraft Class Designation System.

The evolution of squadron designations may be seen by tracing the development of the Aircraft Class Designation System and the parallel changes in the Squadron Designation System. While tracing the evolution of the two designation systems in this introductory chapter, the primary emphasis will be placed on those designations related to carrier aviation. While reading this chapter various references will be made to the Aircraft Class Designation System, Designation of Aircraft, Model Designation of Naval Aircraft, Aircraft Designation System, and Model Designation of Military Aircraft. All of these references refer to the same system involved in designating aircraft classes. This system is then used to develop the specific designations assigned to each type of aircraft operated by the Navy. The F3F-4, TBF-1, AD-3, PBV-5A, A-4, A-6E, and F/A-18C are all examples of specific types of naval aircraft designations which were developed from the Aircraft Class Designation System.

In order to make it easier to understand the evolution and development of the Aircraft Class Designation

System and the Squadron Designation System, each system will be discussed separately in a chronological format. This will help to make comparisons and connections between the two systems and enable the reader to grasp the significant interplay between the two programs.

The Aircraft Class Designation System was developed first. Squadrons and the Squadron Designation System did not come into existence until the post-World War I period. The evolution of the Aircraft Class Designation System is as follows:

## Aircraft Class Designation System

### *Early Period of Naval Aviation up to 1920*

**T**HE UNCERTAINTIES DURING the early period of naval aviation were reflected by the problems encountered in settling on a functional system for designating naval aircraft. Prior to 1920<sup>1</sup> two different Aircraft Class Designation Systems were used. From 1911 up to 1914, naval aircraft were identified by a single letter indicating the general type and manufacturer, followed by a number to indicate the individual plane of that type-manufacturer. Under this system:

- “A” was used for Curtiss hydroaeroplanes
- “B” for Wright hydroaeroplanes
- “C” for Curtiss flying boats
- “D” for Burgess flying boats
- “E” for Curtiss amphibian flying boats

This system had been established in 1911 by Captain Washington I. Chambers, Director of Naval Aviation. The following is a list of the types of aircraft and their designations in existence from 1911–1914:

#### *Aircraft Designation System, 1911–1914*

- A-1 Curtiss hydroaeroplane (originally an amphibian, and the Navy’s first airplane)
- A-2 Curtiss landplane (rebuilt as a hydroaeroplane)
- A-3 Curtiss hydroaeroplane
- A-4 Curtiss hydroaeroplane
- B-1 Wright landplane (converted to hydroaeroplane)
- B-2 Wright type hydroaeroplane
- B-3 Wright type hydroaeroplane
- C-1 Curtiss flying boat
- C-2 Curtiss flying boat
- C-3 Curtiss flying boat
- C-4 Curtiss flying boat
- C-5 Curtiss flying boat
- D-1 Burgess Co. and Curtiss flying boat
- D-2 Burgess Co. and Curtiss flying boat

E-1 OWL (over water and land) (a Curtiss hydroaeroplane rebuilt as a short-hulled flying boat for flying over water or land and fitted with wheels for use as an amphibian)

A new Aircraft Class Designation System was established by Captain Mark L. Bristol, the second Director of Naval Aviation. He assumed the Director’s position from Captain Chambers in December 1913. The new system was issued on 27 March 1914 as General Order 88, “Designation of Air Craft.” This system changed the original designation of the aircraft to two letters and a number, of which the first letter denoted class; the second, type within a class; and the number for the order in which aircraft within the class were acquired. The four classes set up on 27 March 1914 are as follows:

#### *Aircraft Designation System, 1914–1920*

##### Aircraft Classes

“A” for heavier-than-air craft. Within the “A” class:

- L stood for land machines
- H stood for hydroaeroplanes
- B stood for flying boats
- X stood for combination land and water machines (amphibians)
- C stood for convertibles (could be equipped as either land or water machines)

“D” for airships or dirigibles

“B” for balloons

“K” for kites

Under this new system the A-1 aircraft (the Navy’s first airplane) was redesignated AH-1, with the “A” identifying the plane as a heavier-than-air craft and the “H” standing for hydroaeroplane. General Order No. 88 also provided a corresponding link between the old aircraft designations and the new system: “The aeroplanes now in the service are hereby designated as follows:

- A-1 became the AH-1
- A-2 became the AH-2
- A-3 became the AH-3
- B-1 became the AH-4
- B-2 became the AH-5
- B-3 became the AH-6
- C-1 became the AB-1
- C-2 became the AB-2
- C-3 became the AB-3
- C-4 became the AB-4
- C-5 became the AB-5
- D-1 became the AB-6
- D-2 became the AB-7
- E-1 became the AX-1”<sup>2</sup>

<sup>1</sup> Administrative Histories, Office of the Deputy Chief of Naval Operations (Air), Vol. III, Part 1, History of Naval Aviation (1898–1917), p. 120–121.

<sup>2</sup> United States Naval Aviation 1910–1980, NAVAIR publication 00–80P–1, 1981, p. 432.

Despite the phrase, “now in the service,” the A-1, B-1 and B-2 and probably the D-1 had ceased to exist before the order was issued.

### ***The Early 1920s***

In General Order 541, issued in 1920, two overall types of aircraft were identified and assigned permanent letters which have remained in effect since 1920. Lighter-than-air types were identified by the letter Z and heavier-than-air types were assigned the letter V. Within these two categories, various class letters were assigned to further differentiate the aircraft's operation or construction. Class letters assigned to the Z types were R for rigid, N for nonrigid, and K for kite. By combining the type and class designation, the different airships in the Navy's inventory could be categorized. As an example:

ZR referred to rigid dirigibles (airships)  
ZN stood for nonrigid airships  
ZK for kite balloons

The class letters assigned to the heavier-than-air vehicles covered a wider range and generally reflected the mission responsibilities of the aircraft classes. Class letters assigned to the V types were:

F for fighting  
O for observation  
S for scouting  
P for patrol  
T for torpedo  
G for fleet (utility)

By combining the V designation for heavier-than-air vehicles with the class letters, the following aircraft class definitions were assigned in 1920:

VF for fighting plane  
VO for observation plane  
VS for scouting plane  
VP for patrol plane  
VT for torpedo and bombing plane  
VG for fleet plane (most likely a general utility aircraft)

This class designation system for aircraft has continued to remain a functional system and is still used today. There have been many additions, deletions, and major changes to the system over the years but the concept has remained intact. The current naval aircraft inventory still lists VF, VS, VP, VG, VO, and VT aircraft classes. Three of these, VF, VP, and VO, still have the same definitions they were assigned in 1920. The VS, VG, and VT aircraft class designations now refer to antisubmarine (VS), in-flight refueling (VG), and training aircraft (VT).

The aircraft designation system established in July 1920 by General Order 541 was modified on 29 March 1922 by Bureau of Aeronautics Technical Note 213. It added the identity of the manufacturer to the aircraft

model designation. The aircraft class designations remained the same as those issued by General Order 541 (G.O. 541); however, besides the six aircraft classes listed in G.O. 541 (VF, VO, VS, VP, VT, and VG), an additional two classes were added to the aircraft class list. The two new aircraft classes were VA for Training Aircraft and VM for Marine Expeditionary Plane.<sup>3</sup>

### ***The mid to late 1920s***

Between 1922 and 1933, there were only a few modifications to the Aircraft Class Designation System. The Bureau of Aeronautics was established in July 1921 and, thereafter, made changes to the Aircraft Class Designation System. In response to a Secretary of Navy letter dated 13 February 1923, the Bureau of Aeronautics issued a Technical Note on 10 March 1923 that changed the VA designation for training aircraft to VN, dropped the VG designation, and added the VJ designation for Transport Plane.<sup>4</sup> This was followed by the addition, in 1925, of the VX designation for experimental aircraft.<sup>5</sup> The VX designation was dropped from the Aircraft Class Designation list in January 1927.<sup>6</sup> In July 1928, the VM designation was dropped and the VJ designation was changed from Transportation Plane to General Utility. Two new designations were also instituted, VB for bombing and VH for ambulance.<sup>7</sup> A new aircraft class was added in July 1930 and designated VR for transport aircraft.<sup>8</sup> This VR designation has remained in effect for transport aircraft since 1930.

### ***The 1930s***

Similar changes took place in the Aircraft Class Designation System during the early 1930s. By July 1933, there were ten aircraft class designations. This list did not vary much from those aircraft classes identified in the previous ten years. The aircraft class designations in July 1933 were as follows:

VB for bombing  
VF for fighting  
VH for ambulance  
VJ for general utility  
VN for training  
VO for observation

<sup>3</sup> Bureau of Aeronautics Technical Note 213, Type, Class and Model Designation of Airplanes, March 29, 1922.

<sup>4</sup> Bureau of Aeronautics Technical Note No. 235, Type, Class and Model Designation of Airplanes, March 10, 1923.

<sup>5</sup> Bureau of Aeronautics, Model Designation of Naval Aircraft SH-3, 1 January 1925.

<sup>6</sup> Bureau of Aeronautics, Model Designation of Naval Airplanes SH-3C, 1 January 1927.

<sup>7</sup> Bureau of Aeronautics, Model Designation of Naval Airplanes SH-3D, Aer-M-157-CRP, A9-11, July 1928.

<sup>8</sup> Bureau of Aeronautics, Model Designation of Naval Airplanes, SH-3H, Aer-D-157, A9-11, 1 July 1930.

VP for patrol  
 VR for transport  
 VS for scouting  
 VT for torpedo.<sup>9</sup>

A major change was instituted to the Aircraft Designation System on 2 January 1934.<sup>10</sup> Prior to 1934, aircraft classes had been established according to the primary mission the aircraft was to perform. The fact that many aircraft were capable of performing more than one mission was recognized in the revised system by assigning an additional letter to the previous two-letter aircraft class designation. In the new three-letter aircraft class designation, the first letter identified the type of vehicle, such as V for heavier-than-air (fixed wing) and Z for lighter-than-air. For heavier-than-air, the second letter identified the primary mission of the aircraft, using the same 10 letter designations listed in the above paragraph. The third letter indicated the secondary mission of the aircraft class, such as:

F for fighting  
 O for observation  
 B for bombing  
 T for torpedo  
 S for scouting

By assigning these five secondary mission letters to the primary aircraft letter designations, **seven new aircraft class designations were established:**

VBF for bombing-fighting  
 VOS for observation-scouting  
 VPB for patrol-bombing  
 VPT for patrol-torpedo  
 VSB for scouting-bombing  
 VSO for scout-observation  
 VTB for torpedo-bombing

On the eve of World War II, the Model Designation of Airplanes for 1 July 1939 was very similar to what had been identified in 1934. There were eleven primary aircraft class designations and six designations that included a secondary mission letter in its class designation. The 1 July 1939 Model Designation of Airplanes included the following Aircraft Class Designations:

Bombing (VB)  
 Fighting (VF)  
 Miscellaneous (VM)  
 Observation (VO)  
 Patrol (VP)  
 Scouting (VS)

Torpedo (VT)  
 Training (VN)  
 Transport (multi-engine) (VR)  
 Transport (single-engine) (VG)  
 Utility (VJ)  
 Observation-Scouting (VOS)  
 Patrol-Bombing (VPB)  
 Scouting-Bombing (VSB)  
 Scouting-Observation (VSO)  
 Torpedo-Bombing (VTB)  
 Utility-Transport (VJR)

### ***World War II***

The designation changes for the aircraft classes and squadron system during World War II and the immediate postwar period are identified in the Model Designation of Naval Aircraft, the Aviation Circular Letters, and in the Navy Department Bulletins.

By mid-1943, many new aircraft class designations had been added to the Model Designation of Naval Aircraft.<sup>11</sup> The additions included:

VA for ambulance  
 VBT for bombing-torpedo  
 VSN for scout-training  
 VL for gliders  
 VLN for training-gliders  
 VLR for transport-gliders  
 VH for helicopters  
 VHO for observation-helicopters  
 VD for drones  
 VTD for torpedo-drones and/or target drones  
 ZN for nonrigid airships  
 ZNN for nonrigid-training and/or utility airships  
 ZNP for nonrigid patrol and/or scouting airships

As the war progressed, more changes were made to the Model Designation of Naval Aircraft. In July 1944, a major change was instituted for the Aircraft Class Designation System. Naval aircraft were divided into **three main types identified by a letter:**

V for fixed wing vehicles (airplanes, gliders and drones)  
 H for rotary wing vehicles (helicopters)  
 Z for lighter-than-air vehicles (airships)

The three main types were then each subdivided into classes. The classes under the heavier-than-air fixed wing type (V) included:

VF        fighters  
 VF(M)   fighters (medium or 2 engine)  
 VSB      scout bombers  
 VTB      torpedo bombers  
 VO/VS   observation scout

<sup>9</sup> Bureau of Aeronautics, Model Designation of Naval Airplanes SH-3N, Aer-D-157, A9-11, 1 July 1933.

<sup>10</sup> Model Designation of Naval Airplanes, SH-3O, Aer-D-157, A9-11 dated 2 January 1934, p. 1.

<sup>11</sup> Model Designation of Naval Aircraft, SH-3AK, Bureau of Aeronautics, July 1943, p. 1-2.

VPB(HL)	patrol bombers (heavy or 4 engine landplane)
VPB(ML)	patrol bombers (medium or 2 engine landplane)
VPB(HS)	patrol bombers (heavy or 4 engine seaplane)
VPB(MS)	patrol bombers (medium or 2 engine seaplane)
VR(HL)	transport (heavy or 4 engine landplane)
VR(ML)	transport (medium or 2 engine landplane)
VR(HS)	transport (heavy or 4 engine seaplane)
VR(MS)	transport (medium or 2 engine seaplane)
VJ(M)	utility (medium or 2 engine)
VJ	utility
VSN(M)	training
VSN	training
VN	training
VK	drones
VKN	drones (target training)
VL	gliders
VLN	gliders (training)
VLR	gliders (transport)

The helicopter type (H) had the following classes:

HO	helicopters (observation)
HN	helicopters (training)
HR	helicopters (transport)

The lighter-than-air type (Z) had the following classes:

ZN	nonrigid airships
ZNN	nonrigid airships (training)
ZNP	nonrigid airships (patrol and escort)

This July 1944 change to the Model Designation of Naval Aircraft was still in effect at the close of World War II and only a couple of additions had been made. They included:

- VKC for assault drones
- HJ for utility helicopters

### Post World War II and the late 1940s

On 11 March 1946, a major revision was issued to the Class Designation of Naval Aircraft. Aviation Circular Letter Number 43–46 divided naval aircraft into four types and assigned a letter designation. They were:

- V for heavier-than-air (fixed wing)
- K for pilotless aircraft
- H for heavier-than-air (rotary wing)
- Z for lighter-than-air

Within the class designation for **V type aircraft**, the primary mission and class designation were as follows:

<i>Primary Mission</i>	<i>Class Designation</i>
Fighter (destroy enemy aircraft in the air)	VF
Attack (destroy enemy surface or ground targets)	VA
Patrol (search for enemy)	VP
Observation (observe and direct ship and shore gun fire)	VO
Transport purposes	VR

Utility purposes	VU
Training purposes	VT
Gliders	VG

Within the class designation for **H type (rotary wing)**, the primary mission and class designation were as follows:

Air-sea rescue	HH
Observation	HO
Training	HT
Transport	HR
Utility	HU

Within the class designation for **K type (pilotless aircraft)**, the primary mission and class designation were as follows:

For attack on aircraft targets	KA
For attack on ship targets	KS
For attack on ground targets	KG
For use as target aircraft	KD
For utility purposes	KU

Within the class designation for **Z type (lighter-than-air)**, the primary mission and class designation were as follows:

Patrol and escort	ZP
Air-sea rescue	ZH
Training	ZT
Utility	ZU

This order provided that “no changes . . . be made in the model designation of aircraft already produced or in production, except that the mission letter of all BT class aircraft shall be changed to A.”<sup>12</sup> Thus, the SB2C and TBF/TBM aircraft remained in use until they were removed from the inventory, while the BT2D and BTM aircraft were redesignated as AD and AM. These aircraft were assigned to the new attack squadrons established in the latter part of 1946.

In 1947 a modification was made to CNO’s Aviation Circular Letter No. 43–46 of 11 March 1946 whereby a fifth class designation was added to the naval aircraft types. The new class designation was the **M type for Guided Missiles** and the primary mission and class designation were as follows:

Air-to-air	AAM
Air-to-surface	ASM
Air-to-underwater	AUM
Surface-to-air	SAM
Surface-to-surface	SSM
Surface-to-underwater	SUM
Underwater-to-air	UAM
Underwater-to-surface	USM
Test Vehicle	TV

<sup>12</sup> Aviation Circular Letter No. 43–46 of 11 March 1946, OP–517–B1–EPA–dml, serial 63P517, paragraph 10.

Since this volume of the *Dictionary of American Naval Aviation Squadrons* is dealing primarily with the attack community, the remaining discussion on the Aircraft Class Designation System will deal only with the V (heavier-than-air fixed wing) type and its sub-classes. In 1949 the V type was composed of the following classes:

VF Fighter	Air defense and escort
VA Attack	Surface and ground attack
VP Patrol	ASW reconnaissance and attack
VO Observation	Gunfire and artillery spotting
VR Transport	Air logistic support
VU Utility	Fleet utility support
VT Training	Basic and fleet training
VG Glider	

### ***The 1950s, 1960s, 1970s and 1980s***

During the early 1950s several changes were made to the V (heavier-than-air fixed wing) type. The VG glider class was dropped and the following classes were added:

VS Search	Submarine search and attack (carrier)
VW Warning	Airborne early warning

In 1953 the nine classes of the V type were further divided into sub-classes. The V type classes and sub-classes were as follows:

VA Attack	Surface and ground attack
VA (Int'd)	Interdiction
VA (GS)	Ground Support
VA (AW)	All Weather and ASW
VA (W)	Air Early Warning and ASW
VA (H)	Heavy
VF Fighter	Air defense and escort
VF (Int)	Interceptor
VF (Day)	Day, jet
VF (Day)(Prop)	Day, reciprocating
VF (AW)	All weather, jet
VF (AW)(Prop)	All weather, reciprocating
VF (P)	Photographic, jet
VF (P)(Prop)	Photographic, reciprocating
VF (D)	Drone control
VO Observation	Gunfire and artillery spotting
VP Patrol	ASW reconnaissance, mining and weather
VP (L)	Landplane
VP (S)	Seaplane
VP (MIN)	Mining
VP (WEA)	Weather
VP (Q)	Countermeasure
VR Transport	Air logistic support
VR (H)	Heavy landplane
VR (M)	Medium landplane
VR (S)	Heavy seaplane
VR (C)	Carrier

VS Antisubmarine	Submarine search and attack
VS	Search and attack
VS (S)	Attack
VS (W)	Search
VT Training	Basic, fleet and primary training
VT (Jet)	Jet
VT (ME)	Two-engine, reciprocating
VT (SE)	One-engine, reciprocating
VT (E)	Electronic
VT (Nav)	Navigation
VU Utility	Fleet utility support
VU (Gen)	General
VU (SAR)	Search and rescue
VU (Tow)	Tow
VW Warning	Airborne Early Warning
VW	Air early warning

Between 1953 and 1960 there was only one change in the V class and a few modifications in the sub-classes. The VG class, for in-flight refueling tanker, was added in 1958. In 1960 the type letter for the heavier-than-air fixed wing class was still identified as "V", however, it was omitted from the acronym for the class designation. The class designations for the heavier-than-air fixed wing type and their basic mission were as follows:

A	Attack
F	Fighter
G	In-flight refueling tanker
O	Observation
P	Patrol
R	Transport
S	Antisubmarine (for carrier-based aircraft)
T	Training
U	Utility
W	Airborne Early Warning

In 1962 a major change occurred in the model designation for naval aircraft. The Department of Defense consolidated the aircraft designation systems of the Navy, Army, and Air Force. A new DOD (Department of Defense) Directive was established that designated, redesignated, and named military aircraft. Under the new system the V for heavier-than-air fixed wing types was dropped completely and a single letter was used to identify the basic mission of the vehicle. The basic mission and associated type symbols were as follows:

A Attack	Aircraft designed to search out, attack and destroy enemy land or sea targets using conventional or special weapons. Also used for interdiction and close air support missions.
B Bomber	Aircraft designed for bombing enemy targets.
C Cargo/transport	Aircraft designed for carrying cargo and/or passengers.



E Special Electronic	Aircraft possessing ECM capability or installation having electronic devices to permit employment as an early warning radar station.
F Fighter	Aircraft designed to intercept and destroy other aircraft and/or missiles.
H Helicopter	A rotary wing aircraft designed with the capability of flight in any plane; e.g., horizontal, vertical, or diagonal.
K Tanker	Aircraft designed for in-flight refueling of other aircraft.
O Observation	Aircraft designed to observe (through visual/other means) and report tactical information concerning composition and disposition of enemy forces, troops, and supplies in an active combat area.
P Patrol	Long-range, all-weather, multi-engine aircraft operating from land and/or water bases, designed for independent accomplishment of the following functions: antisubmarine warfare, maritime reconnaissance, and mining.
S Antisubmarine	Aircraft designed to search out, detect, identify, attack and destroy enemy submarines.
T Trainer	Aircraft designed for training personnel in the operation of aircraft and/or related equipment, and having provisions for instructor personnel.
U Utility	Aircraft used for miscellaneous missions, such as carrying cargo and/or passengers, towing targets, etc. These aircraft will include those having a small payload.
V VTOL and STOL	Aircraft designed for vertical take-off or landing with no take-off or landing roll, or aircraft capable of take-off and landing in a minimum prescribed distance.
X Research	Aircraft designed for testing configurations of a radical nature. These aircraft are not normally intended for use as tactical aircraft.
Z Airship	A self-propelled lighter-than-air aircraft.

The only type symbol not in use by the Navy from the above listing was the B for bomber aircraft. The O for observation aircraft was in the naval inventory but was used primarily by the Marine Corps.

Between 1962 and 1990 there were only two modifications to the listing of basic mission and aircraft type symbols in DOD's *Model Designation of Military Aircraft, Rockets and Guided Missiles*. These changes involved the addition of the letter "R" for Reconnaissance and the deletion of the Z type for Airships. The basic mission for the R type was an aircraft designed to perform reconnaissance missions.

Even though a consolidated DOD directive was issued on aircraft designations for the Navy, Air Force, and Army in 1962, the Navy continued to publish a listing of naval aircraft classes and sub-classes that differed slightly from the DOD directive. However, the Navy did follow the new procedures for designating its aircraft, as an example, the AD-5 Skyraider aircraft designation was changed to A-1E. The December 1962 issue of the *Allowances and Location of Naval Aircraft* lists the following classes and sub-classes for fixed wing aircraft (note the continued use of "V" as part of the class designation and the failure to change the VG class designation for air refueler to K, as listed by the DOD instruction):

VF Fighter	
VF FB	Fighter-bomber
VF P	Photo Reconnaissance
VA Attack	
VA L	Light Attack
VA LP	Light Attack (Prop)
VA M	Medium Attack
VA H	Heavy Attack
VA P	Photo Reconnaissance (long range)
VA Q	ECM Reconnaissance (long range)
VA QM	Tactical ECM
VA QMP	Tactical ECM (Prop)
VS ASW (Carrier based)	
VP ASW Patrol	
VP L	ASW Patrol (shore based)
VP S	ASW Patrol (sea based)
VW Airborne early warning	
VW M	AEW Medium (carrier based)
VW H	AEW Heavy (shore based)
VR Transport	
VR H	Heavy transport
VR M	Medium transport
VR C	Carrier transport
VG Air refueler, heavy	
VT Trainer	
VT AJ	Advanced jet trainer
VT BJ	Basic jet trainer

VT SJ	Special jet trainer
VT AP	Advanced prop trainer
VT BP	Basic prop trainer
VT PP	Primary prop trainer
VT SP	Special Prop trainer
VK Drone	
VK D	Drone control

The only change to this listing occurred in 1965 with the addition of the VO class for observation. Between 1965 and 1988 there was no change to the aircraft class listing in the *Allowances and Location of Naval Aircraft*. However, there were numerous changes in the listing for the sub-classes. The final publication of the *Allowances and Location of Naval Aircraft* was March 1988.

On 2 May 1975, the Navy selected a derivative of the YF-17 as the winner of the Navy's VFAX competition for a new multimission fighter attack aircraft. The VFAX aircraft was designed to replace two aircraft in the Navy's inventory, the F-4 Phantom II and the A-7 Corsair II. This program was reinstituting an old Navy policy, whereby, multimission requirements for attack and fighter, be incorporated into a single aircraft. Fighter and light attack missions had previously been assigned to various types of aircraft, particularly in the period prior to World War II and also in the 1950s. The Navy was now reverting to an old policy and designing a plane with a dual capacity as a fighter and an attack aircraft to meet new multimission requirements.

The VFAX aircraft was initially assigned the F-18A designation. A new model designation F/A (strike fighter) was established and assigned to the aircraft in the late 1970s. The Navy accepted its first F/A-18 *Hornet* on 16 January 1979. The F/A designation was identified as a sub-class and listed under the VF class in the Navy's *Allowances and Location of Naval Aircraft*. Under the DOD model designation the F/A-18 designation is listed under both the A and F symbol designations as A-18 and F-18.

### **The 1990s**

The following is a list of the Naval Aircraft Class and Sub-classes used in the 1990s:

VF Fighter	
VF FA	Striker Fighter
VF FB	Fighter
VF P	Fighter
VA Attack	
VA L	Attack
VA M	Attack
VA H	Attack
VA P	Attack
VA Q	Attack
VA QM	Attack

VS Antisubmarine

VP Patrol  
  VP L    Patrol

VW Warning  
  VP M    Warning  
  VP H    Warning

VR Transport  
  VR H    Transport  
  VR M    Transport  
  VR C    Transport  
  VR LJ    Transport

VG In-flight Refueling

VO Observation  
  VO L    Observation

VU Utility  
  VU L    Utility  
  VU S    Utility

VT Training  
  VT AJ    Training Jet  
  VT SJ    Training Jet  
  VT PP    Training Prop  
  VT SP    Training Prop  
  VT SG    Training Jet

H Rotary Wing  
  H F    Rotary Wing  
  H A    Rotary Wing  
  H G    Rotary Wing  
  H S    Rotary Wing  
  H H    Rotary Wing  
  H M    Rotary Wing  
  H L    Rotary Wing  
  H T    Rotary Wing  
  H R    Rotary Wing

VK Drones  
  VK D    Drones  
  VK K    Drones Jet

This ends the chronological section on the evolution of the Aircraft Designation System.

## **Squadron Designation System**

**T**HE SQUADRON DESIGNATION SYSTEM did not develop until after World War I. During the prewar and World War I period naval aviation and naval aircraft (excluding Marine Corps aircraft) were primarily aligned with shore-based commands. The majority of the operations were conducted by water-based aircraft assigned to naval air stations. Their primary mission was patrol. By the close of World War I the value of naval aviation as a military weapon had been demon-

strated on land and at sea. In the postwar period, to more fully utilize aviation's potential, it was necessary to extend its capabilities to operate with the fleet.

On 3 February 1919, Captain G. W. Steel, Jr., assumed command of Fleet Air Detachment, Atlantic Fleet. This marked the beginning of an aviation command within the fleet organization.<sup>13</sup> From this beginning, the concept of aviation squadrons evolved into a permanent part of the fleet. In July 1920, the Secretary of the Navy issued two General Orders that played an important role in solidifying a position for naval aviation in the fleet and a role in its future operations. General Order Number 533 (series 1913) of 12 July 1920 "provided for the organization of naval forces afloat into the Atlantic, Pacific and Asiatic Fleets and for the formation of type forces with each fleet, designated as Battleship, Cruiser Destroyer, Submarine, Mine, Air, and Train."<sup>14</sup> Aviation was now a distinct part of the fleet organization. General Order Number 541, issued 17 July 1920 and mentioned earlier in the discussion on the evolution of the Aircraft Class Designations, established the standard nomenclature for the designation of aircraft types and classes (the Aircraft Class Designation System), as well as other naval vessels. The following is a discussion on the evolution of the Squadron Designation System.

### ***Early Period of Naval Aviation up to 1920***

As mentioned earlier, squadrons and the Squadron Designation System did not exist during the early period of naval aviation.

### ***The Early 1920s***

Squadron designations were not immediately identified in the fleet organization after General Order 533 was issued in July 1920. The first known reference to a squadron-like organization in the fleet appears in September 1920 when Airboat Divisions 1 and 2 of Air Force, Atlantic Fleet are identified during their visit to Annapolis.<sup>15</sup> In August 1921, reference was made to Torpedo Plane Squadron 5.<sup>16</sup> This is the first known reference to an aviation squadron with a designation similar to those assigned to the aircraft classes in General Order 541. The "Annual Report of the Chief of the Bureau of Aeronautics for Fiscal Year 1922" emphasized the reorganization of the aviation forces in the fleet. During this reorganization, Air Force, Atlantic Fleet and Air Force, Pacific Fleet were redesignated Air Squadrons, Atlantic Fleet and Air Squadrons, Pacific

Fleet, respectively.<sup>17</sup> The basis for the structure of aviation in the fleet became the aircraft squadron. The first evidence of these changes are found in the fleet organizational structure listed in the Navy Directory dated 1 January 1922. The different types of squadrons listed as being attached to the Atlantic and Pacific fleets are as follows:

#### **Air Squadrons, Atlantic Fleet**

Scouting Squadrons 1 and 2 (combined in December 1921 to form one squadron)  
Torpedo Plane Squadron 1  
Kite Balloon Squadron 1

#### **Air Squadrons, Pacific Fleet**

Spotting Squadrons 4, 3, and L-1  
Combat Squadrons 4, 3, and L-1 (Spotting Squadron L-1 and Combat Squadron L-1 were not established during FY-22 due to lack of personnel)  
Patrol Squadron 1

This is the first instance in which the entire fleet organization of aircraft squadrons is identified and, more or less, corresponds to similar aircraft classes listed in General Order 541. From this point on, there is a natural basis for the parallel association between the Squadron Designation System and the Aircraft Class Designation System.

The Chief of Naval Operations (CNO) issued the "Naval Aviation Organization for Fiscal Year 1923" on 17 June 1922. This document ordered the redesignation of Air Squadrons, Atlantic Fleet and Air Squadrons, Pacific Fleet to Aircraft Squadrons, Scouting Fleet and Aircraft Squadrons, Battle Fleet, respectively. The numbering of aircraft squadrons according to the ship squadron numbers was changed to a system of numbering all air squadrons serially in each class according to the order authorizing them to organize.<sup>18</sup> The use of letter abbreviations to indicate the squadron mission and designation were listed in the "Naval Aeronautic Organization for Fiscal Year 1923." This is the first known record associating the abbreviated Aircraft Class Designations with the abbreviated squadron designations. The squadrons assigned to each fleet under this organization were as follows:

#### ***Aircraft Squadrons, Scouting Fleet***

Scouting Plane Squadron 1 (VS Squadron 1)  
Torpedo and Bombing Plane Squadron 1 (VT Squadron 1)  
Kite Balloon Squadron 1 (ZK Squadron 1)

<sup>13</sup> COMINCH U.S. Fleet letter of 7 February 1919.

<sup>14</sup> United States Naval Aviation 1910–1980, NAVAIR publication 00–80P–1, 1981, p. 48–49.

<sup>15</sup> CNO Daily Aviation News Bulletin, Op–15H–CCT of September 24, 1920.

<sup>16</sup> U.S. Naval Aviation Operations Report for October 8, 1921, p. 7.

<sup>17</sup> Annual Report of the Chief of the Bureau of Aeronautics for the Fiscal Year 1922, Washington Government Printing Office, 1922, p. 5.

<sup>18</sup> Naval Aeronautic Organization for Fiscal Year 1923 issued by CNO ser 26983 of 17 June 1922.

*Aircraft Squadrons, Battle Fleet*

Torpedo and Bombing Plane Squadron 2 (VT Squadron 2)  
 Observation Plane Squadron 1 (VO Squadron 1)  
 Observation Plane Squadron 2 (VO Squadron 2)  
 Observation Plane Squadron 3 (VO Squadron 3)  
 Fighting Plane Squadron 1 (VF Squadron 1)  
 Fighting Plane Squadron 2 (VF Squadron 2)  
 Fighting Plane Squadron 3 (VF Squadron 3)

**The mid to late 1920s**

With the introduction of new types of planes in service and the formation of new squadrons, the Navy made modifications to its system of squadron designations. These changes continued to be issued as General Orders by the Secretary of the Navy, while the changes to the Aircraft Class Designation System were issued by the Bureau of Aeronautics as Technical Notes or later as Model Designation of Naval Airplanes. On 1 July 1927, a new system for designating aircraft squadrons was placed in effect.<sup>19</sup> Under General Order 161, the designation system for squadrons used three categories to identify the squadron: **class designations, squadron identification numbers, and assignment letters.**

The first part of the squadron designation for heavier-than-air units used the following **class designations**:

VO for observation  
 VF for fighting  
 VT for torpedo and bombing  
 VS for scouting  
 VP for patrol  
 VJ for utility  
 VN for training  
 VX for experimental

The second part of the squadron designation used squadron **identification numbers** within each class of squadrons. The numbers began with one and continued in numerical series for each class of squadrons.

The final part of the squadron designation used **assignment letters** to indicate what organization the squadron operated under. **Assignment letters** were as follows:

B for Battle Fleet  
 S for Scouting Fleet  
 A for Asiatic Fleet  
 F for Fleet Base Force  
 C for Control Force  
 D for Naval District (to be followed by district number)  
 M for United States Marine Corps  
 R for United States Naval Reserve  
 U for United States Fleet

By combining the **class designation, squadron identification number, and assignment letter**, the squadron designation would be obtained. For example:

VO-1B stood for Observation Squadron 1 in the Battle Fleet  
 VF-3S stood for Fighting Squadron 3 in the Scouting Fleet  
 VT-5D14 stood for Torpedo and Bombing Squadron 5 assigned to the Fourteenth Naval District

The lighter-than-air squadron designations were as follows:

Nonrigid Airship Squadrons: ZNO, ZNS, ZNP, and ZNN  
 Rigid Airship Squadrons: ZRS, ZRP, and ZRN  
 Kite Balloon Squadrons: ZKO and ZKN

None of the lighter-than-air squadron designations listed above were ever used by the Navy.

This change to the Squadron Designation System, as directed by General Order 161, may be seen in the listing of aviation squadrons published in the 1 April 1928 Navy Directory<sup>20</sup>. The new squadron designations were as follows:

Fighting Plane Squadrons (VF-1B, 2B, 3B, 5B and 6B)  
 Observation Plane Squadrons (VO-1B, 2B and 4B)  
 Torpedo and Bombing Plane Squadrons (VT-1B and VT-2B)  
 Utility Squadron (VJ-1B)  
 Observation Plane Squadrons (VO-3S and VO-5S)  
 Torpedo and Bombing Plane Squadron (VT-9S)  
 Utility Squadron (VJ-2S)  
 West Indian Aerial Survey (VJ-3S)  
 Observation Plane Squadron (VO-11A)  
 Torpedo and Bombing Plane Squadron (VT-5A)  
 Experimental Squadron (VX-1D5)  
 Training Squadrons (VN-6D5, VN-1D8, VN-3D8, VN-5D8, and VN-7D11)  
 Utility Squadrons (VJ-4D5 and VJ-5D11)  
 Torpedo and Bombing Plane Squadrons (VT-6D14, VT-7D14, and VT-8D15)  
 Patrol Squadrons (VP-1D14 and VP-2D15)

A modification was made to General Order 161 on 28 September 1928.<sup>21</sup> This amendment added B for bombing and VB in the class designation category. The aviation squadrons listed for the January 1929 fleet organization<sup>22</sup> include two new squadron designations not identified in the 1928 fleet organization.

<sup>20</sup> Navy Director, Officers of the United States Navy and Marine Corps, April 1, 1928, published by Bureau of Navigation, U.S. Government Printing Office, Washington 1928, p. 128–133.

<sup>21</sup> General Order 179 (series 1921) of September 28, 1928 (Amendment to General Order 161).

<sup>22</sup> Navy Director, Officers of the United States Navy and Marine Corps, January 1, 1929, published by Bureau of Navigation, U.S. Government Printing Office, Washington, 1929.

<sup>19</sup> General Order 161 (series 1921) dated March 5, 1927, System for Designation Aircraft Squadrons.

This listing included the scouting squadrons (VS) and bombing squadrons (VB). The new squadrons listed in January 1929 were:

- Scouting Plane Squadrons (VS-1B, 2B, 3B, and 4B)
- Bombing Plane Squadrons (VB-1B and VB-2B)
- Scouting Plane Squadron (VS-5S)

The January 1929 fleet organization listing also removed some of the old squadrons that had been in the previous fleet organization listings. This was most likely the result of the redesignation of some squadrons and the disestablishment of others. VB-1B and VB-2B were most likely redesignated from VFs (Fighting Squadrons).

The squadron designations listed in the Navy's organization for 1928 and early 1929 correspond to almost all the aircraft class designations listed in the Model Designation of Naval Airplanes for January 1929.<sup>23</sup> Out of the nine aircraft classes listed there is only one aircraft class designation that does not have a corresponding squadron designation. The Navy did not have a squadron with the designation VH until 15 April 1944. VH-1 was the first squadron established as an Air-Sea Rescue Squadron. The use of the same functional designation for aircraft class abbreviations and squadron abbreviations demonstrated the close association between the two designation systems in the late 1920s.

### The 1930s

On 15 May 1930, an update to the system for squadron designations was issued as General Order 202. It canceled General Orders 161 and 179 and became effective 1 July 1930. General Order 202 was almost identical to the previous two general orders. The only change was the removal of bombing from the torpedo and bombing class designation and assigning only torpedo as the functional designation for VT.

General Order 202 remained in effect until 13 May 1935 when another revision was made to the Aircraft Squadron Designation System.<sup>24</sup> General Order 33, effective 13 May 1935, made only one change to General Order 202. The C for Control Force as an assignment letter was deleted. There were no changes to the class designation or squadron identification numbering categories. Essentially, General Order 33 reaffirmed the Aircraft Squadron Designating System that had been instituted by General Order 161, modified by General Order 179 and consolidated by General Order 202.

After ten years of adhering to the same policy for squadron designations, the Navy canceled General Order 33 on 1 July 1937<sup>25</sup> and instituted a new System for Naming Aircraft Squadrons.<sup>26</sup> The new system issued 9 March 1937 and effective 1 July 1937, simply stated "Aircraft squadrons shall be named in accordance with their primary missions and differentiated as necessary by numbers and organization adjective." The functional designation of squadrons was assigned in accordance with the primary mission. The squadron designations promulgated by this CNO letter of 9 March 1937 were the same as those issued by General Order 33, plus the addition of transport as a new functional designation. The functional designations for squadrons issued by the 9 March 1937 letter were:

- bombing (VB)
- fighting (VF)
- observation (VO)
- patrol (VP)
- scouting (VS)
- torpedo (VT)
- training (VN)
- utility (VJ)
- experimental (VX)
- transport (VR)

Under this new System for Naming Aircraft Squadrons, the squadron **letter designation** remained the same as the previous system; however, the **suffix lettering (assignment lettering)** was dropped and a major change was instituted for the numbering of aircraft carrier squadrons. The numbering system was revised to provide for:

1. numbering each carrier squadron according to the hull number of its carrier,
2. each battleship and cruiser squadron was to be assigned the same number as its ship division,
3. patrol squadrons were numbered serially without regard to their assignment.

The primary designations listed for the aircraft classes in July 1937<sup>27</sup> included all of the same designations listed by the CNO's letter of 9 March 1937 for squadron designations except for experimental (VX). Out of the ten designations for squadrons, nine were assigned to active units in the Navy as of September 1937.<sup>28</sup> The Bureau of Aeronautics' "Monthly Report, Status of Naval Aircraft" for July 1937 identified the following squadrons as being in existence (this list does not include Marine Corps or Reserve squadrons):

<sup>25</sup> General Order No. 94 of March 8, 1937.

<sup>26</sup> CNO letter OP-38-E-EMR VZ1/F40-1(370309) of 9 March 1937, System for Naming Aircraft Squadrons.

<sup>27</sup> Bureau of Aeronautics, Model Designation of Naval Airplanes SH-3V, 1 July 1937.

<sup>28</sup> Navy Directory, Officers of the United States Navy and Marine Corps, September 1, 1937, issued by Bureau of Navigation, U.S. Government Printing Office, Washington, 1937.

<sup>23</sup> Bureau of Aeronautics, Model Designation of Naval Airplanes SH-3E, Aer-D-157-CRP, January 1929.

<sup>24</sup> General Order No. 33 of May 13, 1935.

VB-2	VF-2	VB-3	VF-3	VF-5	VF-6
VF-4	VB-5	VS-5	VT-5	VS-42	VB-6
VS-6	VS-2	VS-3	VS-41	VB-4	VT-2
VT-6	VT-3	VJ-1	VP-16	VP-17	VP-14
VP-3	VP-6	VP-8	VP-9	VP-11	VP-12
VP-5	VP-10	VP-4	VP-7	VP-15	VJ-2
VO-1	VO-2	VO-3	VO-4	VCS-2	VCS-3
VCS-4	VCS-5	VCS-6	VCS-7	VP-2	VP-1
VX-2D1	VX-3D4	VX-4D4	VX-4D5	VX-5D5	VN-8D5
VJ-4D5	VN-1D8	VN-2D8	VN-3D8	VN-4D8	VN-5D8
VJ-5D11					

The only designation not in use for squadrons at this time was the one for transport (VR). However, none of the three-letter Aircraft Class Designations (such as VBF, VOS, VPB, VPT, VSB, VSO or VTB) were used in the squadron designation system at this time. The separate but parallel relationship that exists between the system of naming aircraft squadrons and the designations assigned to aircraft classes is apparent. They serve separate purposes, yet, are so closely related in their requirements that they must be regarded as mutually supporting systems.

It is important to note paragraph 7 of the Chief of Naval Operation's letter of 9 March 1937; it states "Model designations of aircraft, published by the Bureau of Aeronautics, employ the same functional designations and corresponding letters (or combinations thereof to indicate secondary as well as primary functions) as are listed herein. These model designations, however, are distinct from and not to be confused with squadron names and abbreviations covered in the Order." The parallel relationship between the two systems is quite evident from this statement, as well as the confusion that develops when it is necessary to show the interdependence of the two systems (Aircraft Class Designation System and the Aircraft Squadron Designation System).

The 1 July 1937 change to the aircraft carrier squadron numbering proved to be a disaster during the massive World War II expansion of naval aviation. With the large increase in the number of aircraft carriers and air groups (with their assigned carrier squadrons), combined with the movement of air groups from one carrier to another, it became impossible to associate the air group's squadron numbers with the hull number of the carrier it was operating from during the war. The counterpart to this, the proliferation of aircraft class designations, with its many primary and secondary missions, subsequently led to many squadron designation changes during World War II and the postwar period. By reviewing the "U.S. Navy Squadron Designation and Abbreviations" listing in Appendix 4, the reader will be able to identify all the changes that occurred in squadron designations between 1942 and 1948 or at any other time frame in naval aviation.

The Squadron Designation System underwent changes similar to those previously mentioned in the Aircraft Class Designation System. A review of the changes in the Squadron Designation System will show the parallel developments between the two systems. In July 1939, a modification was made to the Squadron Designation System that was set up in July 1937. The modification standardized the numbering of patrol squadrons in reference to wings so that the first digit of a patrol squadron designation number became the same as the wing to which it was assigned. The Squadron Designation System that was set up in 1937, which numbered squadrons according to the hull number of its ship or division, became totally impractical during World War II. In early 1941 the squadron designations in use included the following:

- VF for Fighting Squadrons
- VB for Bombing Squadrons
- VT for Torpedo Squadrons
- VS for Scouting Squadrons
- VJ for Utility Squadrons
- VX for Experimental Squadrons
- VP for Patrol Squadrons
- VN for Training Squadrons
- VO for Observation Squadrons
- VCS for Cruiser Scouting Squadrons

### ***World War II***

During the early part of World War II many new squadron designations were established. The following new squadron designations became effective in 1942:

- ZP for Blimp Squadrons
- VGS for Escort Scouting Squadrons
- VGF for Escort Fighting Squadrons
- VR for Transport Squadrons

In late 1942 the Squadron Designation System setup in 1937, and modified in 1939, was discontinued. A new system was issued in January 1943 and became effective 1 March 1943.<sup>29</sup> According to this Navy Department Bulletin, all squadrons were numbered serially without regard to which carrier, battleship, cruiser, or shore station the squadron was assigned. The carrier squadrons that had VSB and VTB aircraft classes assigned were designated in this directive as VB and VT, respectively. Carrier-based dive bombing squadrons (VB) were numbered serially from 1 to 99 and torpedo squadrons (VT) from 1 to 65. There were no changes in the designations for these two types of squadrons under this new directive; however, as the war progressed, the VT squadron numbers increased

<sup>29</sup> SecNav Confidential Ltr (SC) A3-1/VV Serial 0104540 of January 2, 1943, Naval Aircraft Squadrons, Designation and Renumbering of, issued as Navy Department Bulletin C-19 of January 15, 1943, effective 1 March 1943.

from 65 and continued into the three-digit series.

Other squadron designation changes, effective 1 March 1943, included:

- inshore patrol squadrons redesignated VS (scouting squadrons),
- escort fighting squadrons (VGF) became fighting squadrons (VF),
- escort scouting squadrons (VGS) redesignated composite squadrons (VC),
- patrol squadrons operating land-based aircraft became bombing squadrons (VB) with three-digit numbers. This separated them from the bombing squadrons (VB) that were carrier-based and had two-digit numbers.

Squadron designations in existence in March 1943 were as follows:

- VF Fighting Squadrons
- VB Bombing Squadrons (carrier-based)
- VB Bombing Squadrons (Patrol Squadrons flying land-based aircraft)
- VT Torpedo Squadrons
- VC Composite Squadrons
- VP Patrol Squadrons
- VS Scouting Squadrons (included carrier and land-based)
- ZP Blimp Squadrons
- VJ Utility Squadrons
- VR Transport Squadrons
- VD Photographic Squadrons
- VO Observation Squadrons
- VCS Cruiser Scouting Squadrons

Numerous modifications were made to this Squadron Designation System during the remainder of the war. On 1 October 1944, patrol squadrons (VP) and multiengine land-based bombing squadrons (VB) were redesignate patrol bombing squadrons (VPB). Additional new squadron designations in the Squadron Designation System during the latter part of World War II included:

- VBF Bombing Fighting Squadrons
- VFN Night Fighter Squadrons
- VTN Night Torpedo Squadrons
- VOF Observation Fighter Squadrons
- VOC Composite Spotting Squadrons
- VE Evacuation Squadrons
- VH Rescue Squadrons
- VK Special Air Task Force Squadrons
- ZJ Blimp Utility Squadron
- VRE Air Transport Evacuation Squadron
- VRJ Utility Transport Squadron
- VRF Ferry Transport Squadrons
- VRS Service Transport Squadron
- VOS Air Spotting Squadrons

**Post World War II and the late 1940s**

In 1946, to complement the change in the Aircraft Class Designation System (or Class Designation of Naval Aircraft) instituted by Aviation Circular Letter Number 43–46, the Navy issued a major revision to its method of designating naval aircraft squadrons. On 22 July 1946, a Secretary of Navy letter established a new System of Squadron Designations to be effective 1 September 1946.<sup>30</sup> The Secretary of Navy letter was issued as Navy Department Bulletin 46–1543 of 31 July 1946; however, an All Navy Bulletin (ALNAV) 482–46 postponed the effective date of the Secretary of Navy letter. The redesignation of naval aircraft squadrons issued by the Secretary of Navy letter became effective on 15 November 1946 in accordance with Navy Department Bulletin 46–2123.<sup>31</sup> The carrier squadron designations VB and VT were replaced by the designation VA for attack squadrons. This was the first use of the designation VA for attack squadrons. Squadron designations in existence as a result of the 15 November 1946 change were as follows:

- VF Fighting Squadrons
- VA Attack Squadrons
- VCN Night Composite Squadrons
- VP-HL Heavy Patrol Squadrons (landplane)
- VP-ML Medium Patrol Squadrons (landplane)
- VP-MS Medium Patrol Squadrons (seaplane)
- VP-AM Amphibian Patrol Squadrons
- VPM Meteorological Squadrons
- ZP Blimp Squadrons
- VR Transport Squadrons
- VRU Transport Utility Squadrons
- VRF Transport Ferry and Service Squadrons
- VX Experimental and Development Squadrons
- VO Observation Squadrons
- VU Utility Squadrons
- VPP Photographic Squadrons
- VN Training Squadrons

With the establishment of attack squadrons, many of the old VT and VB squadrons were redesignated VA squadrons. The following is a list of VT and VB squadrons redesignated as attack squadrons on 15 November 1946:<sup>32</sup>

- VB-4 redesignated VA-1A
- VB-74 redesignated VA-1B
- VT-41 redesignated VA-1E
- VT-58 redesignated VA-1L

<sup>30</sup> SecNav Itr Serial 203P517, OP–517–B16-EPA:ls of 22 July 1946.

<sup>31</sup> Navy Department Bulletin 46–2123, Redesignation and Renumbering of Fleet Air Groups and Squadrons, Op–55–C–KB, Serial 3P55C of 31 October 1946.

<sup>32</sup> CNO Itr Naval-Marine Aviation Unit Designations, History of, rest. serial 4184P33, A12–1 of 15 December 1947.

VT-4 redesignated VA-2A  
 VT-74 redesignated VA-2B  
 VT-42 redesignated VA-2E  
 VB-3 redesignated VA-3A  
 VB-75 redesignated VA-3B  
 VT-3 redesignated VA-4A  
 VT-75 redesignated VA-4B  
 VB-5 redesignated VA-5A  
 VB-17 redesignated VA-5B  
 VT-5 redesignated VA-6A  
 VT-17 redesignated VA-6B  
 VB-18 redesignated VA-7A  
 VT-18 redesignated VA-8A  
 VB-20 redesignated VA-9A  
 VT-20 redesignated VA-10A  
 VB-11 redesignated VA-11A  
 VT-11 redesignated VA-12A  
 VB-81 redesignated VA-13A  
 VT-81 redesignated VA-14A  
 VB-153 redesignated VA-15A  
 VT-153 redesignated VA-16A  
 VB-82 redesignated VA-17A  
 VT-82 redesignated VA-18A  
 VB-19 redesignated VA-19A  
 VT-19 redesignated VA-20A  
 VB-98 redesignated VA-21A  
 VT-98 redesignated VA-22A

The suffix letters attached to the above designations identifies the squadron's assignment to a particular type of carrier air group and its assignment to a Battle Carrier or Attack Carrier. The "A" suffix was for Attack Carrier assignments and the "B" was for Battle Carriers.

On 6 December 1946, VA-19A became the first fleet operational squadron to have an attack-designated aircraft assigned. The development of a single-seat airplane to execute the missions and functions of the VSB and VTB aircraft classes and the consolidation of these missions into attack squadrons, vice VT and VB squadrons, had finally evolved.

The last major overall change to the Squadron Designation System occurred on 1 September 1948. The VF and VA carrier squadrons were assigned two or three digit numbers. The first digit number was the same as the parent air group number. The suffix letters under the old system were dropped, as an example, VA-22A would have dropped the "A" letter at the end of the designation. Patrol squadrons reverted to the simple VP designation, instead of using the four separate designations of VP-HL, VP-ML, VP-MS, and VP-AM. Special designations for transport squadrons, such as VRF and VRU, became VR. Some VC squadrons became VAW to reflect their air warning mission. As a result of the 1 September 1948 change to the Squadron Designation System, the following squadron designations were in existence:

VF	Fighter Squadrons
VA	Attack Squadrons
VC	Composite Squadrons
VP	Patrol Squadrons
ZP	Blimp Squadrons
VU	Utility Squadrons
VR	Transport Squadrons
VX	Experimental and Development Squadrons
VO	Observation Squadrons
HU	Helicopter Squadrons
VAW	Carrier Air Early Warning Squadrons

Numerous modifications have been made to the Squadron Designation System issued in September 1948, however, these changes have been made on a case by case basis. The Navy has not issued a major directive to change the Squadron Designation System since 1948.

### ***The 1950s, 1960s, 1970s and 1980s***

Since this volume of the *Dictionary of American Naval Aviation Squadrons* is dealing primarily with VA designations and its derivatives, the remaining discussion will deal only with those designations. Various modifications to the VA squadron designation occurred between 1946 and the present. Modifications to VA squadron designations included the establishment of VA(AW), VAH, and VAL squadron designations. The VAH designation was established in the mid-1950s to identify heavy attack squadrons which also had been VC (Composite) squadrons. Their primary mission was the delivery of nuclear weapons from carriers. The VA(AW) designation was also established in the mid-1950s to identify squadrons that were all-weather capable. The VAL (light attack squadron) designation was established during the Vietnam conflict and only one VAL squadron was established. Its mission was to provide surveillance and offensive operations in support of the river patrol forces based in South Vietnam, as well as air support for SEALs (Sea-Air-Land team) and combined U.S. Army, Navy, and South Vietnamese operations.

Numerous other derivatives of the VA squadron designation were established, including VAP, VAQ, VAW, VAK, and VA(HM); however, the primary mission of these squadrons did not involve an attack role. The most likely reason for the use of the VA in these squadron designations may have been because the initial aircraft used by or assigned to the squadrons was a modified attack aircraft.

The most recent modification to the VA squadron designation is the VFA designation. The evolution of the VFA (fighter attack and later strike fighter) squadron designation involved several traditional factors that have influenced aircraft and squadron design-



nations in the past, as well as the addition of certain economic and political aspects. The following are some of the factors that played a role in the creation of the VFA designation:

- increased cost factors surrounding the acquisition of F-14 Tomcats
- Congressional emphasis on achieving greater commonality between Navy and Air Force aircraft (particularly with regard to adopting a derivative of the Air Force's Air Combat Fighter, which involved a competitive flyoff between the YF-17 and YF-16 in the early 1970s)
- the Navy's need for aircraft with new performance, electronics, and weaponry technology to counter the progressively more sophisticated Soviet aircraft
- the Navy's need for an aircraft to replace overage and outdated tactical aircraft and maintain approved tactical force levels
- a need to provide a multipurpose aircraft capable of performing fighter, attack, and support roles, thereby, reducing the different types of aircraft required to be supported by the Navy, especially for those assigned to the carriers

On 13 November 1980, the Navy's first fighter attack squadron, using the VFA designation, was established as VFA-125. The squadron was established with the mission of training fighter and attack pilots to fly the F/A-18 Hornet. On 25 March 1983, VFA-designated squadrons were changed from fighter attack to strike fighter squadrons, but the VFA acronym remained the same.

The similarities between the Squadron Designation System and the Naval Aircraft Class System may be seen by making a final comparison between the two systems as they currently exist. The following is a listing of the current squadron designations:

VF	Fighter Squadron
VA	Attack Squadron
VFA	Strike Fighter Squadron
VAW	Carrier Airborne Early Warning Squadron
VS	Sea Control Squadron
HS	Carrier Helicopter Antisubmarine Squadron
HC	Helicopter Combat Support Squadron
HSL	Helicopter Antisubmarine Squadron Light
HM	Helicopter Mine Countermeasures Squadron
VP	Patrol Squadron
VR	Fleet Logistic Squadron
VRC	Fleet Logistic Support Squadron
VC	Fleet Composite Squadron
VQ	Fleet Air Reconnaissance Squadron
VX	Air Test and Evaluation Squadron
VXE	Antarctic Development Squadron
VXN	Oceanographic Development Squadron
VAQ	Tactical Electronic Warfare Squadron
VPU	Patrol Squadron Special Projects Unit

VFC	Fighter Squadron Composite
VT	Training Squadron
HT	Helicopter Training Squadron
HCS	Helicopter Combat Support Special Squadron

The basic mission symbols for military aircraft classes listed in the DOD Model Designation of Military Aerospace Vehicles for 1990 were as follows:

A	Attack
B	Bomber (not used by the Navy)
C	Transport
E	Special Electronic Installation
F	Fighter
O	Observation
P	Patrol
R	Reconnaissance
S	Antisubmarine
T	Trainer
U	Utility
X	Research

In the Navy's last publication of the *Allowances and Location of Naval Aircraft* (March 1988) the aircraft class listing was as follows:

VF	Fighter
VA	Attack
VS	Antisubmarine
VP	Patrol
VW	Early Warning
VR	Transport
VG	In-flight refueling
VO	Observation
VU	Utility
VT	Trainer
VK	Drones
H	Rotary Wing

The interplay between the two systems is evident from the comparisons presented. The "Naval Aeronautic Organization for Fiscal Year 1923" established the precedent for the corresponding relationship between Aircraft Class Designations and the abbreviated designations used for aircraft squadrons and their missions. From this point on, a parallel association can be drawn between the Squadron Designation System and the Aircraft Class Designation System. This concept has remained a viable union for naval aviation since 17 June 1922, even though numerous changes have occurred within the aircraft classes and squadron designations since 1922.

Modifications to these two systems were, and are, constantly being made to keep pace with the advances in aircraft capabilities and changes in mission requirements and tactical approaches utilized by the squadrons. Needless to say, there have always been exceptions to the rule in this association between the two systems. Special aircraft class designations have

existed at various times without having a corresponding squadron designation and vice versa. However, on the whole, aircraft class designations have had corresponding, or been associated with similar, squadron designations since 1922.

The use of common letter designations in the Aircraft Class Designation System and the Squadron Designation System leaves no doubt about the parallel connection between the two systems. It was only logical that when a new type of aircraft with advanced operating capabilities and new weapon systems was introduced there would be a corresponding development for a new type of squadron. The interplay of technology and tactics continue to be the dominating factors in developing aircraft class and squadron designations.

If the trend toward consolidation of missions into single airframes continues, the types of fixed-wing aircraft operating from the deck of a carrier could be reduced to only four different planes or even less. The trend, no doubt, will continue toward the use of a common airframe that may be designed to perform a wide variety of missions by the addition of specific external pods or interchangeable payloads. The AD (A-1) Skyraider is an example of the use of a common airframe that was modified to perform a variety of missions other than the primary one it had been designed to fulfill. The Navy's Squadron Designation System and Aircraft Designation System will undoubtedly continue to undergo other major revisions in the future to keep pace with changing defense requirements.

# Attack Squadron Histories (VA)

## VA-1E to VA-873

### VA-1E

#### Lineage

Established as Torpedo Squadron FORTY ONE (VT-41) on 26 March 1945.

Redesignated Attack Squadron ONE E (VA-1E) on 15 November 1946.

Disestablished on 1 September 1948. The first and only squadron to be designated VA-1E.

#### Squadron Insignia and Nickname

VT-41's insignia was approved by CNO on 18 July 1945. The insignia depicted the multi-armament capability of the squadron's aircraft. Colors for the insignia were: light blue background with white cloud outlined in black; yellow torpedo with black markings; the machine gun and rockets were gray with black markings and the bomb was black; the shell and mouth of the turtle were green, while the arms, legs, neck and upper face were orange; the flight helmet and lower shell of the turtle were brown and the goggles were black. The outer circle of the insignia was outlined in black.



*Squadron insignia approved for use by VT-41.*

After VT-41 was redesignated VA-1E, the squadron apparently continued to use its original insignia. There is no record of approval for a VA-1E insignia.

Nickname: unknown.

#### Chronology of Significant Events

**1 Mar 1946:** Commander Air Force Pacific Fleet designated the primary mission of VA-1E as antisubmarine warfare (ASW).

**4 Dec 1946:** Escort Carrier Air Group 1 (CVEG-1) was assigned to *Badoeng Strait* (CVE 116) with VA-1E as part of this Hunter-Killer ASW team.

**1947-1948:** Squadron conducted Hunter-Killer ASW operations intermittently from *Badoeng Strait* (CVE 116) in the western Pacific off the coast of California.

#### Home Port Assignments

Location	Assignment Date
NAS Seattle	26 Mar 1945
NAS Pasco	15 Apr 1945
NAS Seattle	04 Jul 1945
NAAS Arlington	10 Jul 1945
MCAAF Gillespie	01 Aug 1945
NAS San Diego	19 Sep 1945

#### Commanding Officers

	Date Assumed Command
LT Joseph P. Keigher (acting)	26 Mar 1945
LT Charles A. Collins	29 Apr 1945
LCDR Kent M. Cushman	14 Sep 1946
LCDR Harold A. Robinson	24 Nov 1947

#### Aircraft Assignment

Type of Aircraft	Date Type First Received
TBM-1/1C	26 Mar 1945
TBM-3	26 Mar 1945
TBF-1	Apr 1945
TBF-1C/P	May 1945
TBM-3E	May 1945
TBM-3S	1948

#### Air Wing Assignments

Air Wing	Tail Code	Assignment Date
CVEG-41/CVEG-1*	BS	26 Mar 1945

\* CVEG-41 was redesignated CVEG-1 on 15 November 1946.



*A squadron TBM-3S Avenger in flight, June 1950 (Courtesy Robert Lawson Collection).*

## VA-1L

### *Lineage*

Established as Torpedo Squadron FIFTY EIGHT (VT-58) on 19 March 1946.

Redesignated Attack Squadron ONE L (VA-1L) on 15 November 1946.

Disestablished on 20 November 1948. The Navy's first and only squadron to be designated VA-1L.

### *Squadron Insignia and Nickname*

CNO approved an insignia for VT-58 on 1 July 1946.



*Insignia approved for use by VT-58.*

The insignia represents the squadron's multimission, day-and-night carrier operational capabilities. Insignia colors were: a red background outlined in black; the aircraft and ship were black with white markings; lightning bolts were silver; lettering was yellow with black outlines; upper half of

the day circle was light blue and lower half was dark blue; the sun, moon and stars were yellow; and the night circle was dark blue on top and black on the bottom.

There is no record of approval for a VA-1L insignia. Nickname: unknown.

### *Chronology of Significant Events*

**Mar 1946:** The squadron's mission, when established, was to work with the Operational Development Force United States Fleet (COMOPDEVFOR). That organization's duties included the operational test and evaluation of new weapons, equipment and methods for use by the fleet; reporting the results; and recommending required training, operating procedures and tactical doctrine. To accomplish this mission, the squadron operated three different types of aircraft, the F6F-5N, SB2C-5 and TBM-3, giving them a day and night capability.

**13 Dec 1946:** The squadron's F6F-5Ns were transferred to VF-1L; thereafter, VA-1L operated only the SB2Cs and TBMs.

**4 Mar 1947:** When the squadron received the TBM-3W aircraft, it also received qualified personnel to support and operate the airborne early warning (AEW) TBMs.

**4 Apr-5 May 1947:** The squadron operated aboard *Saipan* (CVL 48) during her shakedown cruise in the Caribbean.

**Feb 1948:** Squadron aircraft participated in a fly-over during the inauguration ceremonies in Caracas, Venezuela, for President-elect Romulo Gallegos.

**20 Nov 1948:** When VA-1L was disestablished, elements of this squadron, as well as elements from VF-1L and Light Carrier Air Group 1 (CVLG-1), were combined to form Aircraft Development Squadron 3 (VX-3).

### *Home Port Assignments*

<i>Location</i>	<i>Assignment Date</i>
NAAS Fentress	19 Mar 1946
NAS Atlantic City	19 Jun 1946

### *Commanding Officers*

	<i>Date Assumed Command</i>
LT Dean S. Laird (acting)	19 Mar 1946
LCDR Samuel G. Parsons	29 Apr 1946
LCDR John W. Shong	20 Aug 1946
LCDR Laurence W. Abbott, Jr.	13 Jun 1948

### *Aircraft Assignment*

<i>Type of Aircraft</i>	<i>Date Type First Received</i>
F6F-5N	May 1946
SB2C-5	May 1946
TBM-3/3E	May 1946
TBM-3N	Dec 1946
TBM-3W	04 Mar 1947
XBT2D-1	Jan 1948
AD-2	19 Oct 1948



*A squadron TBM Avenger catches the wire aboard Saipan (CVL 48) (Courtesy Robert Lawson Collection).*

**Major Overseas Deployments**

<i>Date of Departure</i>	<i>Date of Return</i>	<i>Air Wing</i>	<i>Carrier</i>	<i>Type of Aircraft</i>	<i>Area of Operation</i>
07 Feb 1948	24 Feb 1948	CVLG-1	CVL 48	TBM-3N/E	Carib

**Air Wing Assignments**

<i>Air Wing</i>	<i>Tail Code</i>	<i>Assignment Date</i>
CVLG-58/CVLG-1*	SA	19 Mar 1946

---

\* CVLG-58 was redesignated CVLG-1 on 15 November 1946.

## VA-12

### Lineage

Established as Bomber-Fighter Squadron FOUR (VBF-4) on 12 May 1945.

Redesignated Fighter Squadron TWO A (VF-2A) on 15 November 1946.

Redesignated Fighter Squadron TWELVE (VF-12) on 2 August 1948.

Redesignated Attack Squadron TWELVE (VA-12) on 1 August 1955, the first squadron to be assigned the VA-12 designation.

Disestablished on 1 October 1986.

### Squadron Insignia and Nickname

The squadron's first insignia was approved by CNO on 19 December 1945. Insignia colors were as follows:



*The squadron's first approved insignia used by VBF-4.*

crimson circular background; four of spades on white background with black markings; black bomb with white eyes, mouth, arms and other white markings; brown gloves; gold wings; and pink fire on the bomb fuse.

There are no records indicating VF-2A changed the VBF-4 insignia following redesignation. In 1949, almost a year after VF-2A was redesignated VF-12, the squadron requested approval for a new insignia. CNO approved VF-12's new insignia on 29 September 1949. The theme of the new insignia, "Kiss of Death," was well illustrated: black background; white skull and letters; red lips; and the inner circle and squadron designation was outlined in red.

When VF-12 was redesignated VA-12, the squadron continued to use the "Kiss of Death" insignia. It became a well-known insignia and was used by the squadron until its disestablishment in 1986.

Nickname: Ubangis, Date unknown-1982

Clinchers, 1982-1986

### Chronology of Significant Events

**5 Oct 1945:** The squadron participated in an aerial parade over Washington, D.C., in honor of Fleet Admiral Chester W. Nimitz. It also engaged in several other air parades and exhibition flights during the month of October.

**6 Oct 1945:** VBF-4's commanding officer, Lieutenant Commander Lackey, was killed during a training flight in an SNJ.

**21 Aug-19 Sep and Nov-Dec 1946:** The squadron



*The squadron's second insignia, the "Kiss of Death" design, was approved for squadron use in 1949.*

operated ashore at Kobler Field, Saipan. Conducted training and preparations for special fleet exercises while shore based.

**26 Apr 1952:** The squadron was embarked in *Wasp* (CV 18) en route to the Mediterranean when the carrier collided with the *Hobson* (DMS 26) which sank along with

her 176 men. There were no injuries to squadron personnel. The squadron's F2H-2s remained aboard until *Wasp* entered dry dock at New York to repair her catapults which were damaged in the collision.

**19 Aug 1953:** While operating from *Franklin D. Roosevelt* (CVA 42) in the Mediterranean Sea, the squadron's commanding officer, Lieutenant Commander Breen, was lost at sea.

**Feb 1955:** VA-12 supported the evacuation of Chinese Nationalist civilians and military personnel from the Tachen Islands which were being bombarded by the People's Republic of China.

**1 Aug 1955:** With the redesignation of VF-12 to VA-12 and the acquisition of a new type of aircraft in December 1955, the F7U Cutlass, the squadron's mission changed from jet intercept to special weapons attack.

**14-27 Nov 1960:** VA-12, embarked in *Shangri-La* (CVA 38), was part of the task force ordered to the coast of Central America to counter the infiltration of Cubans into Guatemala and Nicaragua.

**21-27 Nov 1961:** VA-12, embarked in *Franklin D. Roosevelt*, operated off the coast of the Dominican Republic to support the newly established democratic government.

**Apr 1962:** VA-12 was selected by CNO to conduct "Operation Trap," a test firing of Bullpup missiles to evaluate their usefulness to the Navy. The test firings took place while the squadron was based at their home port of NAS Cecil Field.

**Jul-Aug 1963:** A-4C detachments from the squadron operated aboard *Essex* (CVS 9) and *Intrepid* (CVS 11) as fighter support for antisubmarine exercises. These operations were also used to help develop and evaluate ASW tactics and doctrine.

**8-29 Aug 1964:** *Franklin D. Roosevelt* and her air wing were ordered to operate in the vicinity of Cyprus after fighting escalated between Turkish and Greek forces on the island.

**Aug 1966:** VA-12 flew its first combat sortie since its establishment 21 years earlier. The squadron completed its Vietnam deployment in December 1966 without sustaining any combat damage to its aircraft.

12 Nov 1966: VA-12's commanding officer, Commander Robert C. Frosio, was lost at sea during flight operations from *Franklin D. Roosevelt*.

14 Dec 1966: Commander Barnett, commanding officer of VA-12, led a 42-plane strike against a heavily defended target in North Vietnam and for which he was awarded the Silver Star.

Oct-Dec 1973: *Independence* (CV 62) and VA-12 took station southeast of Crete after the outbreak of war between Israel, Egypt and Syria on 6 October 1973. During this period of operations the squadron conducted surveillance flights against a large Soviet fleet that had sortied from the Black Sea.

Aug 1974: As a result of the crisis on Cyprus, *Independence*, with VA-12 aboard, was stationed off the coast of Crete. Tensions increased significantly on 19 August when the American Ambassador to Cyprus, Roger Davies, was killed by a Cypriot mob. The squadron prepared for possible assistance in the evacuation of American nationals. It flew surveillance of Greek, Turkish and Soviet naval and merchant activity in the area.

7 Sep 1974: The squadron participated in the search for victims of a TWA airliner crash in the Ionian Sea. No survivors were located.

15 Apr 1980: VA-12 deployed aboard *Dwight D. Eisenhower* (CVN 69) to the Indian Ocean in response to the Iran-American Embassy hostage situation. The squadron was at sea for 254 days with only one port call during the entire eight and one-half month deployment.

Jun, Aug and Sep 1983: VA-12 operated from *Dwight D. Eisenhower* while on station off the coast of Lebanon. The squadron flew in support of the multinational peacekeeping force stationed in Beirut.

23 Oct 1983: *Dwight D. Eisenhower* and her air wing returned to the coast of Beirut after 241 Marines died in a terrorist-suicide attack there.

1 Oct 1986: VA-12 was disestablished, bringing to a close the long history of the squadron and its motto "Kiss of Death."

**Home Port Assignment**

Location	Assignment Date
NAS Alameda	12 May 1945
NAAS Watsonville	21 May 1945
NAS Wildwood	09 Jul 1945
NAAS Groton	09 Sep 1945
NAS Norfolk	18 Jan 1946
NAS San Diego (North Island)	15 Jul 1946
NAS Norfolk	21 Feb 1949
NAAS Cecil Field	25 Feb 1949
NAS Jacksonville	24 Mar 1950
NAAS Cecil Field	25 Mar 1951
NAS Jacksonville	07 Oct 1951
NAAS Cecil Field	28 Feb 1952
NAS Jacksonville	16 May 1952
NAS Cecil Field	13 Oct 1952

**Commanding Officers**

	Date Assumed Command
LTJG Joseph F. Simpson (acting)	12 May 1945
LTJG John S. Tyler (acting)	15 May 1945
LCDR John H. Lackey	19 May 1945
LCDR William L. Conley	06 Oct 1945
LCDR Richard H. Guinn	21 Jun 1947
LCDR W. H. Kilgore (acting)	07 May 1948
LCDR Ronald W. Hoel	02 Jul 1948
LCDR Albert W. Newhall, Jr.	03 May 1949
CDR Brainard T. Macomber	29 Jun 1950
LCDR John L. Carter	02 Nov 1951
LCDR John M. Breen	15 Dec 1952
LCDR Hamilton McWhorter	19 Aug 1953
CDR Frederick G. Kidd	Oct 1954
CDR Paul H. Durand	Aug 1955
CDR Marshall P. Deputy, Jr.	Jan 1957
CDR Charles A. Pendleton, Jr.	10 Jan 1958
CDR William B. Barrow	22 Jan 1959
CDR Richard J. Deprez	Mar 1960
CDR John E. Hansen	18 Jun 1961
CDR Robert E. Oechslin	14 Jun 1962
CDR Max E. Malan	14 Jun 1963
CDR Burton E. Berglund	15 Jun 1964
CDR James D. Whyte	30 Apr 1965
CDR Robert C. Frosio	Apr 1966
CDR Gerald P. Barnett	18 Nov 1966
CDR Austin C. O'Brien, Jr.	21 Nov 1967
CDR Richard M. Fletcher	Nov 1968
CDR Walter R. Petersen	30 Sep 1969
CDR Daniel H. L. Gholson	10 Jul 1970
LCDR Henry E. Nelson	16 Jun 1971
CDR Anthony A. Less	30 Jun 1972
CDR John F. Calhoun	Oct 1973
CDR James M. Hickerson	1975
CDR Gary W. Mau	14 Feb 1976
CDR David R. Edwards	10 May 1977
CDR Richard B. Curtis	26 Jul 1978
CDR Robert A. Maier	01 Nov 1979
CDR Audrey B. Whitten	26 Feb 1981
CDR James M. Gill	19 May 1982
CDR Michael W. Samuels	01 Oct 1983
CDR Harry M. Conner	21 May 1985

**Aircraft Assignment**

Type of Aircraft	Date Type First Received
F6F	23 May 1945
F4U-1/1D and FG-1/1D	23 May 1945
F4U-4	30 Sep 1945
F8F-1/1B	May 1947
F6F-5P	May 1947

**Aircraft Assignment—Continued**

<i>Type of Aircraft</i>	<i>Date Type First Received</i>
F2H-1	01 Sep 1950
F2H-2	Dec 1950
F7U-3	Dec 1955
A4D-1	Apr 1957
A4D-2	Jan 1958
A4D-2N (A-4C)*	08 Jan 1962
A-4E	08 Mar 1965
A-4C	09 Mar 1967
A-7E	01 Apr 1971

\*In 1962, the Navy's aircraft designation system was changed and the A4D-2N was redesignated the A-4C Skyhawk.



*A flight of squadron F4U-4s deployed aboard Tarawa (CV 40) operating from Naval Air Base Kobler, Saipan, in August 1946.*

**Major Overseas Deployments**

<i>Date of Departure</i>	<i>Date of Return</i>	<i>Air Wing</i>	<i>Carrier</i>	<i>Type of Aircraft</i>	<i>Area of Operation</i>
28 Jun 1946	15 Jul 1946	CVG-4	CV 40	F4U-4	Transit to West Coast via Panama Canal
01 Aug 1946	29 Apr 1947	CVG-4/CVAG-1	CV 40	F4U-4	WestPac
01 Oct 1948	21 Feb 1949	CVG-1	CV 40	F8F-1	World Cruise
20 Mar 1951	06 Oct 1951	CVG-1	CVB 43	F2H-2	Med
24 May 1952	11 Oct 1952	CVG-1	CV 18	F2H-2	Med/NorLant
11 Jun 1953	03 Dec 1953	CVG-1	CVA 42	F2H-2	Med
27 Dec 1954	14 Jul 1955	CVG-1	CVA 41	F2H-2	World Cruise
02 Sep 1958	12 Mar 1959	CVG-10	CVA 59	A4D-2	Med
06 Sep 1960	20 Oct 1960	CVG-10	CVA 38	A4D-2	NorLant
14 Nov 1960	27 Nov 1960	CVG-10	CVA 38	A4D-2	Carib
15 Feb 1961	28 Aug 1961	CVG-1	CVA 42	A4D-2	Med



*The squadron's F2H Banshee, second from left, in formation with other aircraft from Air Group 1.*



**Major Overseas Deployments—Continued**

<i>Date of Departure</i>	<i>Date of Return</i>	<i>Air Wing</i>	<i>Carrier</i>	<i>Type of Aircraft</i>	<i>Area of Operation</i>
19 Nov 1961	30 Nov 1961	CVG-1	CVA 42	A4D-2	Carib
14 Sep 1962	22 Apr 1963	CVG-1	CVA 42	A4D-2N	Med
28 Apr 1964	22 Dec 1964	CVW-1	CVA 42	A-4C	Med
28 Jun 1965	17 Dec 1965	CVW-1	CVA 42	A-4E	Med
21 Jun 1966	21 Feb 1967	CVW-1	CVA 42	A-4E	WestPac/Vietnam
24 Aug 1967	19 May 1968	CVW-1	CVA 42	A-4C	Med
07 Jan 1969	29 Jul 1969	CVW-8	CVA 38	A-4C	Med
05 Mar 1970	17 Dec 1970	CVW-8	CVS 38	A-4C	WestPac/Vietnam
16 Sep 1971	16 Mar 1972	CVW-7	CVA 62	A-7E	NorLant/Med
21 Jun 1973	19 Jan 1974	CVW-7	CVA 62	A-7E	Med
19 Jul 1974	21 Jan 1975	CVW-7	CV 62	A-7E	Med
15 Oct 1975	05 May 1976	CVW-7	CV 62	A-7E	NorLant/Med
31 Mar 1977	21 Oct 1977	CVW-7	CV 62	A-7E	Med
16 Jan 1979	13 Jul 1979	CVW-7	CVN 69	A-7E	Med
15 Apr 1980	22 Dec 1980	CVW-7	CVN 69	A-7E	IO
20 Aug 1981	07 Oct 1981	CVW-7	CVN 69	A-7E	NorLant
05 Jan 1982	13 Jul 1982	CVW-7	CVN 69	A-7E	Med
27 Apr 1983	02 Dec 1983	CVW-7	CVN 69	A-7E	Med
08 May 1984	20 Jun 1984	CVW-7	CVN 69	A-7E	NorLant
10 Oct 1984	08 May 1985	CVW-7	CVN 69	A-7E	Med

**Air Wing Assignments**

<i>Air Wing</i>	<i>Tail Code</i>	<i>Assignment Date</i>
CVG-4/CVAG-1/CVG-1*	T†	12 May 1945
CVG-10	AK	20 Jan 1958
CVG-1/CVW-1‡	AB	05 Dec 1960
CVW-8	AJ	25 Aug 1968
CVW-7	AG	1971

\* CVG-4 was redesignated CVAG-1 on 15 November 1946 and CVG-1 on 1 September 1948.

† CVG-4 assigned the tail code T when it was assigned to the carrier *Tarawa* (CV 40) in January 1946.

‡ Carrier Air Groups were redesignated Carrier Air Wings on 20 December 1963, hence, CVG-1 became CVW-1.



*A couple of squadron A-4Cs with markings from their deployment aboard Shangri-La with Air Group 8.*



*A squadron F7U-3 Cutlass, circa 1956 (Courtesy Robert Lawson Collection).*

**Unit Awards Received**

<i>Unit Award</i>	<i>Inclusive Dates Covering Unit Award</i>	
NAVE	01 Jul 1964	30 Jun 1965
AFEM	06 Jun 1983	14 Jun 1983
	27 Jul 1983	30 Aug 1983
	01 Sep 1983	19 Oct 1983
	27 Oct 1983	20 Nov 1983
	11 Apr 1970	06 Nov 1970
MUC	29 Apr 1980	16 Jul 1980
	22 Jul 1980	08 Dec 1980
	25 May 1983	27 May 1983

**Unit Awards Received—Continued**

<i>Unit Award</i>	<i>Inclusive Dates Covering Unit Award</i>	
NUC	29 Apr 1980	10 Dec 1980
	21 Jul 1983	20 Nov 1983
VNSM	30 Jul 1966	
	09 Aug 1966	12 Sep 1966
	01 Oct 1966	03 Oct 1966
	19 Oct 1966	14 Nov 1966
	24 Nov 1966	28 Dec 1966
	20 Jan 1967	21 Jan 1967

**Unit Awards Received—Continued**

<i>Unit Award</i>	<i>Inclusive Dates Covering Unit Award</i>	
	10 Apr 1970	02 May 1970
	12 May 1970	29 May 1970
	13 Jun 1970	04 Jul 1970
	28 Jul 1970	19 Aug 1970
	30 Aug 1970	30 Sep 1970
	20 Oct 1970	07 Nov 1970
RVNGC	21 Oct 1966	



*A flight of squadron A-7E Corsair IIs in their low-visibility paint scheme.*

## VA-15

### Lineage

Established as Torpedo Squadron FOUR (VT-4) on 10 January 1942.

Redesignated Attack Squadron TWO A (VA-2A) on 15 November 1946.

Redesignated Attack Squadron FIFTEEN (VA-15) on 2 August 1948.

Disestablished on 1 June 1969. The first squadron to be assigned the VA-15 designation.

### Squadron Insignia and Nickname

The squadron's insignia was approved by BuAer on 22 April 1942. The theme of the insignia was VT-4 sweeps the seas. The lion represented the squadron's TBD-1 Devastator, and the six teeth were for the number of Devastators assigned to it. Colors in the insignia were as follows: circular outline in black; background white; the sea a deep blue with pale blue marks, torpedo pearl gray with black outline and marks; lion ocher



The squadron's first insignia was approved for VT-4 by the Bureau of Aeronautics.

outlined in black with black markings; white eyes outlined in black with black pupils; nose black; teeth white, lips and mouth red; and the broom was lemon yellow outlined in black with red dashes on lower part of broom.

There is no record of VA-2A's changing the insignia following its redesignation from VT-4. Three years after the squadron was redesignated, VA-15 requested a modification to the old VT-4 insignia.



In 1951, a modification to the squadron's original lion insignia was approved.

On 19 September 1951, CNO approved the modification. The lion was retained to represent the strong attack capabilities of the squadron and the torpedo was replaced by a missile. The background color of the upper half of the insignia was red to represent the flames of past targets, and the lower half was blue to indicate water and the squadron's carrier-based capabilities. Other insignia colors included a

white circular border; lion in gold with brown markings; and the missile and ripples in the water white. This insignia remained with VA-15 until it was disestablished in 1969.

Nickname: Valions, mid-1950s–1969

### Chronology of Significant Events

**10 Jan 1942:** Torpedo Squadron FOUR (VT-4) was established aboard *Ranger* (CV 4) while the ship was in port at Grassy Bay, Bermuda.



A squadron TBD-1 launches from *Ranger* (CV 4) sometime in early 1942.

**8 Aug 1943:** *Ranger*, with VT-4 aboard, met the convoy with the liner *Queen Mary*, which was bringing Winston Churchill to North America for the Quebec Conference.

**Aug–Nov 1943:** VT-4, while deployed aboard *Ranger*, operated as part of the British Home Fleet.

**4 Oct 1943:** The squadron participated in Operation Leader and struck at shipping targets around Kunna Head, Norway, while other elements of CVG-4 struck targets at Bodo, Norway. The squadron's TBF-1 Avengers, along with its escort of F4F Wildcats, destroyed a German freighter and a small coaster and damaged a troop transport.



Squadron TBFs attack a German coaster off the coast of Norway in October 1943.

**Oct 1943:** VT-4, flying from *Ranger*, operated with the British Second Battle Squadron and patrolled the waters of the Norwegian Sea.

**1 May 1944:** CVG-4 reformed as a spare air group with a composition that was designed to include 36 fighter aircraft (F6F), 36 scout-bomber aircraft (SB2C) and 18 torpedo aircraft (TBF/TBM). This air group

composition was organized to operate from the large deck carriers of the *Essex* class. Squadrons in CVG-4 included VT-4, VF-4 and VB-4. This change also brought an end to Air Group FOUR's operations aboard *Ranger*.

**Jul 1944:** VT-4 and CVG-4 transferred from Atlantic to Pacific Fleet.

**15-21 Jul 1944:** VT-4 aboard *Barnes* (CVE 20) en route to Pearl Harbor from San Diego.

**21 Sep 1944:** During a pre-dawn sortie involving simulated torpedo tactics, three of the squadron's aircraft collided with each other, resulting in the loss of nine personnel, including the squadron's commanding officer, Lieutenant Commander Homer H. Hutcheson.

**4-17 Nov 1944:** CVG-4 and VT-4 were temporarily embarked on *Bunker Hill* (CV 17) for operations in support of landings at Leyte. The squadron participated in combat strikes at Ormoc Bay, Cavite and Clark Field.

**Dec 1944:** The squadron participated in combat operations in support of landings on Mindoro.

**Jan 1945:** While operating from *Essex* (CV 9), the squadron struck targets on Formosa, Luzon, Hainan and the Ryukyu Island chain as well as in French Indochina (Vietnam). Operations in Vietnam were around Saigon and Camranh Bay. These operations were in support of the continued assault against the Japanese in the Philippines.

**16 Feb 1945:** The squadron conducted its first strikes against the home islands of Japan, hitting Mawatari airfield on Honshu. Other strikes against targets on Honshu were conducted on 17 and 25 February.

**19-22 Feb 1945:** CVG-4 provided support for landings on Iwo Jima.

**1 Mar 1945:** The airfield, facilities and shipping at Naha, Okinawa, were hit by squadron aircraft.

**4 Mar 1945:** VT-4 disembarked from *Essex* at Ulithi completing the squadron's last combat cruise during World War II.

**9-23 Mar 1945:** CVG-4 aboard *Long Island* (CVE 1) for passage from Ulithi to Pearl Harbor. VT-4 eventually returned to the States in April 1945 for reforming following its combat cruise.

**15 Feb-15 Apr 1946:** VT-4 along with other squadrons in CVG-4, participated in *Tarawa's* (CV 40) shakedown cruise in the Caribbean Sea following the ship's commissioning in December 1945.

**Nov 1946:** Some squadron aircraft were fitted with sonobuoy gear and personnel were trained in antisubmarine missions as well as their normal torpedo-attack requirements.

**22 May 1950:** VA-15, along with the other squadrons in CVG-1, were designated as training squadrons and CVG-1 as a training air group. The squadron's primary mission was the training of fleet pilots in attack aircraft. VA-15's training syllabus emphasized glide

bombing, dive-bombing, rocket firing, day-and-night tactics and carrier qualifications in the AD Skyraider.

**13-23 Sep 1952:** VA-15, while deployed aboard *Wasp* (CVA 18), participated in the first NATO naval operation, Operation Mainbrace, conducted in the North Atlantic.

**Feb 1955:** While deployed aboard *Midway* (CVA 41), the squadron supported the evacuation of Chinese Nationalist civilians and military personnel from the Tachen Islands which were being bombarded by the People's Republic of China.

**Nov-Dec 1956:** As a result of the Suez Crisis, VA-15 deployed aboard *Forrestal* (CVA 59) and operated in the vicinity of the Azores.

**12 Sep 1958:** VA-15 was assigned the additional mission of in-flight refueling (Buddy Stores).

**14-28 Nov 1960:** VA-15, temporarily assigned to CVG-10, deployed aboard *Shangri-La* (CVA 38) to the Caribbean Sea to guard against possible infiltration into Guatemala and Nicaragua by insurgent organizations that were believed to have ties to Cuba.

**21-27 Nov 1961:** VA-15, embarked in *Franklin D. Roosevelt* (CVA 42), operated off the coast of the Dominican Republic to support the newly established democratic government.

**Mar-Apr 1962:** VA-15 deployed aboard *Enterprise* (CVAN 65) to the Caribbean and participated in the shakedown cruise of the world's first nuclear powered carrier.

**Aug 1965:** VA-15 began training under VA-44 for transition to the A-4 Skyhawk.

**4 Apr-21 Nov 1966:** VA-15 deployed to Vietnam as a component of CVW-10 embarked on *Intrepid* (CVS 11). CVW-10 was an all-attack air wing comprised of four attack squadrons, two squadrons flying A-4 Skyhawks and two squadrons with A-1 Skyraiders.

**15 May 1966:** The squadron flew its first combat mission since March 1945 when it was designated VT-4 and a member of Carrier Air Group 4.

### Home Port Assignments

Location	Assignment Date
NAS Norfolk	Mar 1942
NAS Quonset Point	Apr 1942
NAAF Ayer (Fort Devens)	May 1944
NAS Pearl Harbor	Jul 1944
NAS Hilo Field	Aug 1944
NAS Alameda	Apr 1945
NAAS Watsonville	21 May 1945
NAS Quonset Point	11 Jul 1945
NAAF Groton	Aug 1945
NAS Norfolk	Apr 1946
NAS San Diego	15 Jul 1946
NAAS Cecil Field	21 Mar 1949
NAS Jacksonville	09 Jan 1950
NAAS Cecil Field (NAS)*	29 Feb 1952

**Home Port Assignments—Continued**

Location	Assignment Date
NAS Jacksonville	Jul 1957
NAS Oceana	Apr 1965
NAS Cecil Field	Aug 1965

\* Naval Air Auxiliary Station, Cecil Field (NAAS Cecil Field), was redesignated Naval Air Station, Cecil Field (NAS), on 30 June 1952.

**Commanding Officers**

	Date Assumed Command
LT Wallace A. Sherrill	10 Jan 1942
LCDR David W. Taylor, Jr.	Dec 1942
LCDR Homer H. Hutcheson	Dec 1943
LT P. J. Davis, Jr.	Sep 1944
LT John Warren (acting)	12 May 1945
LT Frederic Viewig, Jr. (acting)	23 May 1945
LCDR J. P. Barron	26 Sep 1945
LCDR John A. Camera	Jul 1946
CDR Charles E. Roemer	07 Jul 1947
LCDR Robert A. Newcomb (acting)	29 May 1948
CDR Paul C. Lovelace	30 Aug 1948
LCDR Clay A. Mitchell (acting)	03 Jun 1950
LCDR John E. Lacouture	12 Jul 1950
LCDR Roy M. Isaman	21 Dec 1951
LCDR W. R. Prescott	05 Jan 1953
CDR John B. Bain	Jan 1954
CDR L. B. Jennings	24 Aug 1955
LCDR William J. Gray	10 Dec 1957
CDR J. Patterson, Jr.	18 Sep 1959

**Commanding Officers—Continued**

	Date Assumed Command
CDR Ted L. Farrell	30 Nov 1960
CDR David L. Munns	06 Nov 1961
CDR Joseph L. Coleman	26 Nov 1962
CDR R. G. Bowerman	04 Oct 1963
CDR Steven D. Marvin	01 Apr 1964
CDR Jack L. Gracey	12 Aug 1965
CDR Isaac F. Jones, Jr.	27 Sep 1966
CDR William K. Carr (acting)	29 Jan 1967
CDR William K. Carr	10 Feb 1967
CDR James M. Snyder	14 Feb 1968
CDR Richard G. Daly	15 Feb 1969

**Aircraft Assignment**

Type of Aircraft	Date Type First Received
TBD-1	Jan 1942
TBF-1	Aug 1942
TBF-1C/TBM-1C	Jan 1944
TBM-3	Jan 1945
TBM-3E	May 1945
TBM-3Q	1946
AD-4	19 Aug 1949
AD-4L	08 Mar 1951
AD-6/A-1H*	May 1954
A-4B	Dec 1965
A-4C	Dec 1966

\* AD-6 designation changed in 1962 to A-1H.



*It is believed that this photo of the squadron's AD-6 Skyraiders was taken in 1962 when they operated aboard Enterprise (CVAN 65) during its shakedown cruise in the Caribbean. The squadron never made an overseas deployment aboard Enterprise.*

**Major Overseas Deployment**

<i>Date of Departure</i>	<i>Date of Return</i>	<i>Air Wing</i>	<i>Carrier</i>	<i>Type of Aircraft</i>	<i>Area of Operation</i>
10 Jan 1942	19 Mar 1942	<i>Ranger</i> Air Group	CV 4	TBD-1	Bermuda
02 Jun 1942	22 Jun 1942	<i>Ranger</i> Air Group	CV 4	TBD-1	Newfoundland
08 Jan 1943	30 Jan 1943	*	CV 4	TBF-1	Morocco
13 Feb 1943	06 Mar 1943	*	CV 4	TBF-1	Morocco
23 Mar 1943	27 Jul 1943	CVG-4	CV 4†	TBF-1	Newfoundland
05 Aug 1943	03 Dec 1943	CVG-4	CV 4	TBF-1	NorLant/ Norwegian Sea
05 Nov 1944	17 Nov 1944	CVG-4	CV 17	TBM-1C	Philippines
22 Nov 1944	02 Dec 1944	CVG-4	CV 9	TBM-1C	Philippines
11 Dec 1944	24 Dec 1944	CVG-4	CV 9	TBM-1C	Philippines
30 Dec 1944	26 Jan 1945	CVG-4	CV 9	TBM-1C/3	South China Sea/ Philippines/ Formosa/Okinawa
10 Feb 1945	04 Mar 1945	CVG-4	CV 9	TBM-3	Japan/Iwo Jima/ Okinawa
28 Jun 1946	15 Jul 1946	CVG-4	CV 40	TBM-3E/Q	Transit to West Coast via Panama Canal
01 Aug 1946	29 Apr 1947	CVG-4/CVAG-1	CV 40	TBM-3E/Q	WestPac
01 Oct 1948	23 Dec 1948	CVG-13	CV 37	TBM-3E	WestPac
20 Mar 1951	06 Oct 1951	CVG-1	CVB 43	AD-4/L	Med
24 May 1952	11 Oct 1952	CVG-1	CVA 18	AD-4/L	Med/NorLant
11 Jun 1953	03 Dec 1953	CVG-1	CVA 42	AD-4/B/L	Med
27 Dec 1954	14 Jul 1955	CVG-1	CVA 41	AD-6	World Cruise
07 Nov 1956	12 Dec 1956	CVG-1	CVA 59	AD-6	Azores
15 Jan 1957	22 Jul 1957	CVG-1	CVA 59	AD-6	Med
16 Aug 1957	21 Oct 1957	CVG-1	CVA 59	AD-6	NorLant
13 Feb 1959	01 Sep 1959	CVG-1	CVA 42	AD-6	Med
28 Jan 1960	24 Aug 1960	CVG-1	CVA 42	AD-6	Med
14 Nov 1960	28 Nov 1960	CVG-10	CVA 38	AD-6	Carib
15 Feb 1961	28 Aug 1961	CVG-1	CVA 42	AD-6	Med
19 Nov 1961	30 Nov 1961	CVG-1	CVA 42	AD-6	Carib
14 Sep 1962	22 Apr 1963	CVG-1	CVA 42	AD-6	Med
28 Apr 1964	22 Dec 1964	CVW-1	CVA 42	A-1H	Med
04 Apr 1966	21 Nov 1966	CVW-10	CVS 11	A-4B	Med/IO/WestPac/ Vietnam
11 May 1967	30 Dec 1967	CVW-10	CVS 11	A-4C	Med/IO/WestPac/ Vietnam
22 Jul 1968	29 Apr 1969	CVW-17	CVA 59	A-4C	Med

\* Half of VT-4's aircraft were aboard for this cruise which ferried Army P-40 fighters to Morocco. There were no other squadrons from *Ranger's* Air Group aboard for this cruise.

† *Ranger* returned to Boston during late March for four days of repairs and then back to Newfoundland for operations.

**Air Wing Assignments**

Air Wing	Tail Code	Assignment Date
Ranger Air Group/ CVG-4/CVAG-1/CVG-1*	T†	10 Jan 1942
CVG-13	P	23 Sep 1948
CVG-1/CVW-1§	T/AB‡	23 Feb 1949
RCVW-4/VA-44**		Aug 1965
CVW-10	AK	Jan 1966
CVW-17	AA	16 Jan 1968

\* Ranger Air Group was formed on 1 July 1938. When VT-4 was established on 10 January 1942, it became part of the Ranger Air Group. The Ranger Air Group was redesignated Carrier Air Group FOUR (CVG-4) on 3 August 1943. CVG-4 was redesignated Attack Carrier Air Group ONE (CVAG-1) on 15 November 1946. The CVAG-1 designation was changed to CVG-1 on 1 September 1948.

† This tail code assignment was used beginning in 1946.

‡ Carrier Air Group 1's tail code was changed from T to AB in the latter part of 1957. The effective date was most likely the beginning of FY 58 (1 July 1957).

§ Carrier Air Groups were redesignated Carrier Air Wings on 20 December 1963; hence, CVG-1 became CVW-1.

\*\* During VA-15's transition to the A-4 Skyhawk, the squadron was assigned to VA-44, a Fleet Readiness Training Squadron, for operational training. VA-44 was assigned to Readiness Attack Carrier Air Wing FOUR (RCVW-4).

**Unit Awards Received**

Unit Award	Inclusive Dates Covering Unit Award	
NAVE	1953	
	01 Jul 1960	30 Jun 1961
	01 Jul 1961	30 Jun 1962
NUC	12 Jun 1967	08 Dec 1967
RVNGC	01 May 1966	01 Oct 1966
	21 Jun 1967	13 Jul 1967
	29 Jul 1967	27 Aug 1967
	14 Sep 1967	12 Oct 1967
	31 Oct 1967	24 Nov 1967
VNSM	14 May 1966	15 Jun 1966
	08 Jul 1966	10 Aug 1966
	01 Sep 1966	23 Sep 1966
	02 Oct 1966	18 Oct 1966
	21 Jun 1967	13 Jul 1967
	29 Jul 1967	27 Aug 1967
	14 Sep 1967	12 Oct 1967
	31 Oct 1967	24 Nov 1967
PUC	11 Nov 1944	25 Nov 1944
	14 Dec 1944	16 Dec 1944
	03 Jan 1945	22 Jan 1945
	16 Feb 1945	01 Mar 1945
Campaign Medal (European)	02 Oct 1943	06 Oct 1943
NEM	20 Nov 1961	29 Nov 1961



A flight of squadron A-4C Skyhawks sport markings from its combat cruise to Vietnam on Intrepid. Notice the bomb silhouettes next to the squadron insignia identifying the number of combat sorties flown by the aircraft. The unofficial "Tonkin Gulf Yacht Club" insignia is on the tail of the planes.

## VA-16

### Lineage

Established as Attack Squadron SIXTEEN (VA-16) on 1 June 1955.

Disestablished on 1 March 1958. The first and only squadron to be designated VA-16.

### Squadron Insignia and Nickname

VA-16's insignia was approved by CNO on 24 July 1956. The squadron's design centered around a black knight symbolizing valor and dedication to duty. The background was divided into two fields of gold and gray to signify vigilance both day and night. A blue border surrounded the insignia. VA-16's motto was "Per Aspera Ad Metam" (through adversities to the target). There is no copy of the insignia in the squadron's file.

Nickname: unknown

### Chronology of Significant Events

**Jun 1955:** The squadron was established with a mission of all-weather attack, including special (nuclear) weapons delivery.

### Major Overseas Deployments

Date of Departure	Date of Return	Air Wing	Carrier	Type of Aircraft	Area of Operation
21 Jan 1957	27 Jul 1957	ATG-182	CVA 39	AD-6	Med

### Air Wing Assignments

Air Wing	Tail Code	Assignment Date
ATG-182*	O/AN†	01 Jun 1955

\* Air Task Group ONE EIGHTY TWO (ATG-182). Air Task Groups were non-established Carrier Air Group equivalents created for the first time during the Korean War when the requirement for such units exceeded the statutory limit on their number. They were composed of squadrons withdrawn from existing air groups, which had been determined to operate more effectively with four instead of a larger number of assigned squadrons. ATG-182 was organized in 1955 and remained in existence until 1959.

† Air Task Group 182's tail code was changed from O to AN in the latter part of 1957. The effective date was most likely the beginning of FY 58 (1 July 1957).

**Apr 1957:** VA-16, while deployed to the Mediterranean aboard *Lake Champlain* (CVA 39), operated off the coast of Lebanon during the Jordanian crisis.

**18 Dec 1957:** VA-16 conducted the first air-to-air refueling by an operational AD Skyraider squadron using the "buddy store." The refueling took place over NAS Oceana and the squadron's AD-6 refueled an F9F-8.

**9 Jan 1958:** The squadron conducted the first carrier-based AD Skyraider in-flight refueling while operating from *Ranger* (CVA 61).

### Home Port Assignments

Location	Assignment Date
NAS Oceana	01 Jun 1955

### Commanding Officers

	Date Assumed Command
CDR Bartholomew J. Connolly III	Aug 1955
CDR Richard W. Willis	Jul 1957

### Aircraft Assignment

Type of Aircraft	Date Type First Received
AD-6	Jun 1955



The squadron's AD-6 Skyraiders are spotted on the flight deck aft of the rear centerline elevator. This photo was taken in June 1957 when *Lake Champlain* (CVA 39) was at anchor in Cannes, France.



## VA-21A

### Lineage

Established as Bombing Squadron NINETY EIGHT (VB-98) on 28 August 1944.

Redesignated Attack Squadron TWENTY ONE A (VA-21A) on 15 November 1946.

Disestablished on 5 August 1947. The first and only squadron to be designated VA-21A.



*The squadron's only officially approved insignia.*

### Squadron Insignia and Nickname

There is no record of an approved insignia for VB-98. In 1947, an insignia was approved for VA-21A. However, squadron files do not indicate the colors used in the insignia.

Nickname: unknown

### Chronology of Significant Events

28 Aug 1944: VB-98 was established with the mission of providing a pool of trained dive-bomber pilots and aircrewmembers for assignment as replacements to squadrons operating in the Pacific. The training included carrier landing qualifications, gunnery, bombing and night flying. When VB-98 was redesignated VA-21A, the mission remained the same.

### Home Port Assignments

<i>Location</i>	<i>Assignment Date</i>
NAAS Ventura (Oxnard)	28 Aug 1944
NAAS Los Alamitos	25 Nov 1944
NAS San Diego	26 Aug 1946

### Commanding Officers

	<i>Date Assumed Command</i>
LCDR James D. Ramage	05 Sep 1944
LCDR Martin D. Carmody	01 Jun 1946
LCDR Louis L. Bangs	18 Nov 1946
LT Mark T. Essling (acting)	07 Jun 1947
LCDR C. T. Durgin, Jr.	03 Jul 1947

### Aircraft Assignment

<i>Type of Aircraft</i>	<i>Date Type First Received</i>
SB2C-3	Sep 1944
SBD-6	Sep 1944
SB2C-4	Oct 1944
FM-2	Oct 1944
SBD-5	Nov 1944
SBW-3	Dec 1944
SBW-4E	Mar 1945
SB2C-5	Apr 1945

### Air Wing Assignments

<i>Air Wing</i>	<i>Tail Code</i>	<i>Assignment Date</i>
CVG-98/CVAG-21*	RI†	28 Aug 1944

\* CVG-98 redesignated CVAG-21 on 15 November 1946.

† Tail code assigned to CVAG-21 on 12 December 1946.



*A flight of squadron SB2C-3 Helldivers, September 1944.*

## VA-22A

### *Lineage*

Established as Torpedo Squadron NINETY EIGHT (VT-98) on 28 August 1944.

Redesignated Attack Squadron TWENTY TWO A (VA-22A) on 15 November 1946.

Disestablished on 5 August 1947. The first and only squadron to be designated VA-22A.



*The time frame for the squadron's use of this insignia is unknown.*

### **Squadron Insignia and Nickname**

There is no record of an approval date for VT-98's insignia. The motto of the squadron was "Parati—in Pace-Aut Bello" (Prepared—in Peace or War). Colors of the insignia were: dark blue background; banners white with red lettering; gold naval aviator wings; light blue crest; yellow sword; white clouds outlined in blue; yellow and gold torch; and black torpedo.

There is no record of an approved insignia for VA-22A.

Nickname: unknown

### **Chronology of Significant Events**

**28 Aug 1944:** VT-98 was established with the mission of providing a pool of trained torpedo plane pilots and aircrewmembers for assignment as replacements to squadrons operating in the Pacific.

### **Home Port Assignments**

<i>Location</i>	<i>Assignment Date</i>
NAAS Ventura (Oxnard)	28 Aug 1944
NAAS Los Alamitos	01 Dec 1944
NAS San Diego	25 Aug 1946

### **Commanding Officers**

	<i>Date Assumed Command</i>
LCDR Tom B. Bash	28 Aug 1944
LT Jack C. Heishman (acting)	03 May 1945
LCDR Leo Meacher	12 Jul 1945
LCDR Paul N. Gray	15 Jul 1947

### **Aircraft Assignment**

<i>Type of Aircraft</i>	<i>Date Type First Received</i>
TBF-1	Aug 1944
TBM-1C	Aug 1944
TBM-3	Oct 1944
TBM-3E	May 1945

### **Air Wing Assignments**

<i>Air Wing</i>	<i>Tail Code</i>	<i>Assignment Date</i>
CVG-98/CVAG-21*	RI†	28 Aug 1944

\* CVG-98 redesignated CVAG-21 on 15 November 1946.

† Tail code assigned to CVAG-21 on 12 December 1946.

## VA-23

### Lineage

Established as Reserve Fighter Squadron SIX HUNDRED FIFTY THREE (VF-653) in December 1949.

Called to active duty on 1 February 1951.

Redesignated Fighter Squadron ONE HUNDRED FIFTY ONE (VF-151) on 4 February 1953.

Redesignated Attack Squadron ONE HUNDRED FIFTY ONE (VA-151) on 7 February 1956.

Redesignated Attack Squadron TWENTY THREE (VA-23) on 23 February 1959.

Disestablished on 1 April 1970. The first and only squadron to be designated VA-23.

### Squadron Insignia and Nickname

The squadron's first insignia was approved by CNO on 7 February 1951. The central figure is the dragon,



*The squadron's first officially approved insignia, used by VF-653.*

symbolizing the terrifying qualities representative of a fighter squadron, and the shield portraying its strength. Insignia colors were: yellow outer border; blue background; red dragon with yellow shaded areas and black markings; light blue shield with diamond and checkered bar in yellow.

When the squadron was redesignated VF-151, it adopted a new insignia sometime between 1953 and 1955. This insignia was a shield with a knight's helmet at the top and a scroll at the bottom. The Latin inscription "In Omnia Paratus" on the scroll translated as "Always Prepared." Colors for this insignia were: white background with the outer circle in black; the helmet, scroll, outer section of the shield and the bar across the shield were black; visor of the helmet was yellow with black markings; the two central portions of the shield and the Latin lettering was yellow; the helmet plume



*This insignia was adopted by the squadron sometime in the mid-1950s. It was used by VF-151 and VA-151. When VF-151 was redesignated VA-151, the appropriate change in the scroll showed the VA-151 designation.*



*The insignia used by VF-151 and VA-151 was adopted by VA-23.*

was yellow and black. There is no record relating to the use of this insignia following the squadron's redesignation to VA-151. However, on 29 April 1959, CNO approved VA-23's request to retain the insignia formerly used by VA-151. The insignia used by VA-23 was the Black Knight insignia.

Nickname: Black Knights, circa 1955–1970

### Chronology of Significant Events

**11 Dec 1951:** The squadron conducted its first combat strikes.

**Feb 1955:** The squadron, deployed aboard *Wasp* (CVA 18), provided air support during the evacuation of Chinese Nationalists from the Tachen Islands following the bombardment of the islands by the People's Republic of China.

**Apr 1965:** While operating from *Midway*, on Yankee Station, VA-23 conducted its first combat operations since the Korean War.

**25 Apr 1965:** The squadron became the first to use the Shrike missile in combat. The Shrike is an antiradiation missile for use against radar sites.

**15–20 Mar 1968:** VA-23, along with other squadrons in CVW-19, conducted flight operations from *Ticonderoga* (CVA 14) in the Sea of Japan. These operations were part of a continuing show of American forces in the area, named Operation Formation Star, following the capture of *Pueblo* (AGER 2) by North Korea on 23 January 1968.

**Apr 1968:** VA-23 flew combat strikes around Khe Sanh, South Vietnam, in support of the besieged Marine base.

**20 Mar 1970:** A disestablishment ceremony was held by the squadron under the direction of its last commanding officer, Commander Theodore L. Lloyd, Jr. Commander Lloyd accepted the colors of the squadron and brought to a close over 19 years of active service. The squadron was officially disestablished on 1 April 1970.

### Home Port Assignments

Location Assignment	Date
NAS Akron	Dec 1949
NAS Alameda	16 Apr 1951
NAS Lemoore	30 Sep 1961

**Commanding Officers**

	<i>Date Assumed Command</i>
LCDR Cook Cleland	Dec 1949
LCDR J. M. Rickabaugh	28 Aug 1952
LCDR Benjamin Tappan, Jr.	Nov 1953
CDR E. S. Parks	Jun 1955
LCDR Robert H. Moore, Jr.	*
LCDR Bernard Sevilla	Jan 1957
CDR E. W. Blackburn	30 May 1958
CDR L. M. Cauble	06 Mar 1959
CDR S. G. Gorsline, Jr.	08 Apr 1960
LCDR Edward E. Riley (acting)	28 Sep 1961
CDR G. M. Veling	06 Nov 1961
CDR Edward E. Riley	18 Sep 1962
CDR Robert P. Smith	20 Aug 1963



*A squadron F4U-4 Corsair, July 1951 (Courtesy Robert Lauson Collection).*

**Commanding Officers—Continued**

	<i>Date Assumed Command</i>
CDR John R. Dewenter	02 Jul 1964
CDR Robert R. King, Jr.	02 Jul 1965
CDR Richard A. Mackell	01 Jul 1966
CDR Charles L. Bush	23 Jun 1967
CDR Morris A. Peelle	24 Jul 1968
CDR Theodore L. Lloyd, Jr.	09 Jul 1969

\* Lieutenant Commander Robert H. Moore assumed command of the squadron sometime between late 1955 and early 1956.

**Aircraft Assignment**

<i>Type of Aircraft</i>	<i>Date Type First Received</i>
FG-1D	*
F4U-4	1951†
F4U-4B	1951‡
F9F-2	28 Aug 1952
F9F-5	02 Oct 1952
F7U-3M	May 1955
F7U-3	Jun 1955
F9F-8B	Dec 1956
F9F-8	Jan 1957
FJ-4B	Jul 1957
A4D-2	18 May 1960
A-4E	26 Dec 1962
A-4F	13 Jul 1967

\* Prior to being activated, the squadron flew the FG-1Ds which were assigned to NAS Akron, a reserve naval air station.

† The squadron received the F4U-4 in either April or May 1951.

‡ The squadron received the F4U-4B sometime between June and August 1951.



*Two of the squadron's F9F-2 Panthers fly over Wasp (CVA 18) during her deployment to the western Pacific between September 1954 and April 1955 (Courtesy Robert Lauson Collection).*

**Major Overseas Deployment**

<i>Date of Departure</i>	<i>Date of Return</i>	<i>Air Wing</i>	<i>Carrier</i>	<i>Type of Aircraft</i>	<i>Area of Operation</i>
12 Oct 1951	03 Jul 1952	ATG-1	CV 45	F4U-4/4B	WestPac/Korea
30 Mar 1953	28 Nov 1953	ATG-1	CVA 21	F9F-2	WestPac/Korea
01 Sep 1954	11 Apr 1955	ATG-1	CVA 18	F9F-2	WestPac
25 May 1956	20 Dec 1956	ATG-1	CVA 16	F7U-3	WestPac
04 Oct 1958	16 Feb 1959	ATG-1	CVA 14	FJ-4B	WestPac
15 Aug 1959	25 Mar 1960	CVG-2	CVA 41	FJ-4B	WestPac
16 Feb 1961	28 Sep 1961	CVG-2	CVA 41	A4D-2	WestPac
06 Apr 1962	20 Oct 1962	CVG-2	CVA 41	A4D-2	WestPac
08 Nov 1963	26 May 1964	CVW-2	CVA 41	A-4E	WestPac
06 Mar 1965	23 Nov 1965	CVW-2	CVA 41	A-4E	WestPac/Vietnam
29 Jul 1966	23 Feb 1967	CVW-2	CVA 43	A-4E	WestPac/Vietnam
28 Dec 1967	17 Aug 1968	CVW-19	CVA 14	A-4F	WestPac/Vietnam
14 Apr 1969	17 Nov 1969	CVW-19	CVA 34	A-4F	WestPac/Vietnam



*A squadron F7U-3 Cutlass prepares for a launch from Lexington (CVA 16) during her deployment to the western Pacific in 1956.*



An FJ-4B Fury prepares to engage a aerial refueling basket during the squadron's deployment aboard Ticonderoga (CVA 14) during its 1958–1959 deployment to WestPac.

**Air Wing Assignments**

<i>Air Wing</i>	<i>Tail Code</i>	<i>Assignment Date</i>
CVG-15	H	05 Apr 1951
ATG-1	*	03 Aug 1951
CVG-15	H	03 Jul 1952
ATG-1	U/NA*	01 Nov 1952
CVG-2/CVW-2†	NE	24 Feb 1959
CVW-19	NM	01 Jul 1967

\* The squadron deployed with ATG-1 but used its parent air group tail code (H) until the tail code "U" was assigned to ATG-1 on 24 July 1956. ATG-1's tail code was changed from U to NA in 1957. The effective date was most likely the beginning of FY 58 (1 July 1957).

† Carrier Air Groups were redesignated Carrier Air Wings (CVG-2 became CVW-2) on 20 December 1963.

**Unit Awards Received**

<i>Unit Award</i>	<i>Inclusive Dates Covering Unit Award</i>	
KSM	04 Dec 1951	20 Jun 1952
	03 Apr 1953	09 Aug 1953
	22 Aug 1953	21 Nov 1953
NUC	11 Dec 1951	11 Jun 1952
	16 Apr 1965	04 Nov 1965
	12 Aug 1966	01 Feb 1967
	26 Jan 1968	23 Jul 1968
KPUC	07 Dec 1951	20 Jun 1952
	30 Apr 1953	27 Jul 1953
UNSM	04 Dec 1951	20 Jun 1952
	03 Apr 1953	09 Aug 1953
	22 Aug 1953	21 Nov 1953
NDSM (Korea)	Dec 1951	Jun 1952
AFEM	23 Oct 1958	01 Jan 1959
	28 Mar 1961	07 Apr 1961
	23 Jan 1968	22 Mar 1968
	17 Sep 1969	
MUC	28 Sep 1969	04 Oct 1969
	05 May 1969	03 Nov 1969
VNSM	22 Jul 1965	26 Aug 1965
	11 Sep 1965	09 Oct 1965
	12 Sep 1966	19 Oct 1966
	30 Oct 1966	04 Dec 1966
	26 Dec 1966	01 Feb 1967
	25 Jan 1968	04 Mar 1968
	25 Mar 1968	08 Apr 1968
	16 Apr 1968	
	24 Apr 1968	12 May 1968
	20 May 1968	14 Jun 1968
25 Jun 1968	23 Jul 1968	
05 May 1969	04 Jun 1969	
15 Jun 1969	01 Jul 1969	
12 Jul 1969	30 Jul 1969	
14 Aug 1969	12 Sep 1969	
08 Oct 1969	31 Oct 1969	



Two of the squadron's A-4F Skyhawks fly a training mission over the Imperial Valley of southern California in 1967.

## SECOND VA-34

### Lineage

Established as Fighter Squadron TWENTY (VF-20) on 15 October 1943.

Redesignated Fighter Squadron NINE A (VF-9A) on 15 November 1946.

Redesignated Fighter Squadron NINETY ONE (VF-91) on 12 August 1948.

Redesignated Fighter Squadron THIRTY FOUR (VF-34) on 15 February 1950.

Redesignated Attack Squadron THIRTY FOUR (VA-34) on 1 July 1955.

Disestablished on 1 June 1969. The second squadron to be assigned the VA-34 designation.

### Squadron Insignia and Nickname

The first insignia used by the squadron was a “Joker” breaking out of a deck of cards carrying a machine gun. This insignia was selected by the squadron because the young and inexperienced pilots in the squadron were referred to as the “Jokers.” It was approved by CNO on 15 March 1944. Colors for the insignia were: the deck of cards was outlined in black with the diamond marking on the back of the card in blue and white; the face



*The squadron's first insignia was approved for use by VF-20 during World War II.*

of the card was white with black outlines and lettering; the Joker's hat and neck garment were blue; his right arm was yellow and the other arm white, outlined in black; a black and white machine gun; facial features of Joker outlined in black; and the ripped portion of the card was in the blue and white diamond design.

The next insignia adopted by the squadron was the outline of a human skull. This insignia was approved by CNO on 1 February 1946. Superimposed on the nose of a skull was a human skeleton with the arms holding paddles that became the eyes of the skull, while the teeth were represented by the word “Fighting 20.” The colors were primarily black and white, with the exception of the paddles (eyes) and the lettering which were red. On 28 February 1947 CNO, approved a modification of this insignia which changed the Fighting 20 to Fighting 9A.

On 10 June 1949, CNO approved another modification to the squadron insignia which embellished the skull design. The background became a blue diamond



*A new insignia was adopted by the squadron and approved in 1946. A modification to this insignia was made in 1947 that changed the “Fighting 20” to “Fighting 9A.”*



*A new insignia was adopted by the squadron and approved in June 1949. This insignia is a well-known design that was in use from 1949 until the squadron's disestablishment in 1969.*

outlined in black. Red stylized wings outlined in blue and white were added, as well as a black and white machine gun in the shape of a cigarette with a yellow ammunition belt and red bullets. The machine gun was held by the skelton's hand which was outlined in black. Fighting 9A was dropped and replaced by regular shaped teeth. The skull remained white outlined in black and the LSO paddles were red and white.

Nickname: Blue Blasters, 1957–1969

### Chronology of Significant Events

**16 Apr 1944:** The squadron departed NAS Alameda aboard *Essex* (CV 9) en route to Hawaii for four months of operational training prior to its first combat tour.

**31 Aug 1944:** Combat strikes were flown against the Bonin Islands. This was the squadron's first combat action.

**24–25 Oct 1944:** The squadron participated in the Battle for Leyte Gulf, sometimes referred to as the Second Battle of the Philippines Sea. VF-20 aircraft struck elements of all three Japanese Task Forces which were converging on Leyte Gulf.

**Aug–Nov 1944:** The squadron flew strikes against targets on the Bonin Islands, Yap and Palau Islands, Peleliu Island, Okinawa, Formosa, Luzon, and Leyte.

**14 Dec 1944:** Lieutenant (jg) Douglas Baker was on a strike mission against Clark Field on Luzon when he encountered Japanese fighter opposition. During this engagement he destroyed four Japanese aircraft before being shot down by anti-aircraft fire and lost in the action. This final action brought his air-to-air kills to 16, making him one of the high ranking aces for the Navy. Only eight other Navy pilots equalled or exceeded this record.

**Dec 1944–Jan 1945:** VF-20 engaged in another series of combat actions, flying missions against targets on and around Luzon, Formosa, French Indochina (Vietnam), Hong Kong, the South China Sea, and

Okinawa. Many of these operations were in support of the landings at Lingayen Gulf.

**22 Jan 1945:** This was the last day of combat action for the squadron during World War II. During the period from 31 August 1944, the squadron compiled a formidable combat record. There were 8 aces (9 counting the Commander of CVG-20 who flew the squadron's aircraft), 12 individuals received the Navy Cross and 22 individuals received the Silver Star. VF-20 credits itself with the destruction of over 15 ships and 407 aircraft, not counting an even greater number that were damaged but not destroyed.

**Feb 1945:** Embarked in *Kwajalein* (CVE 98) at Ulithi and departed for the United States, arriving there in the latter part of the month.

**Jul-Sep 1948:** In cooperation with Commander Operational Development Force, Atlantic Fleet, the squadron participated in the experimental carrier controlled approach program aboard *Philippine Sea* (CV 47).

**Apr 1953:** The squadron embarked on *Antietam* (CVA 36) with its F2H-2s to conduct evaluation tests on the Navy's first angled deck carrier.

**26 May 1954:** The squadron was aboard *Bennington* (CVA 20), en route to the Mediterranean Sea, when an explosion aboard ship resulted in the death of 7 squadron personnel. The ship returned to the States and the squadron disembarked.

**31 Oct 1954:** Ensign Duane L. Varner completed a 1,900 mile nonstop, non-refueling, transcontinental flight from Los Alamitos, California, to NAS Cecil Field, Florida, in a squadron F2H-2 Banshee. His flight took 3 hours and 58 minutes and set a new long distance record for the Banshee.

**4 Mar 1958:** During cross-deck operations the squadron landed its A4D-1 Skyhawks aboard HMS *Ark Royal*.

**Jul 1958:** VA-34 flew support missions during the amphibious landings in Beirut, Lebanon, by U.S. Marines.

**Jun 1959:** Operating from NAAS Mayport, the squadron conducted the first operational firing of the Bull Pup air-to-ground missile in the Atlantic Fleet.

**Apr 1961:** VA-34's A4D-2 Skyhawks operated from *Essex* (CVS 9) in the Caribbean Sea during the Bay of Pigs invasion. This operation involved the first use of jet attack aircraft as part of an ASW Air Group, CVSG-60, operating aboard an ASW designated carrier.

**26 Oct-18 Nov 1962:** During the Cuban missile crisis the entire squadron flew aboard *Enterprise* (CVAN 65) on 26 October to augment the assigned air wing. *Enterprise* had departed for the Caribbean on 19 October. VA-34 flew numerous missions in support of Cuban quarantine.

**18-26 Nov 1962:** On 18 November the squadron transferred from *Enterprise* to *Independence* (CVA 62) during the quarantine operations. VA-34 continued to

fly quarantine missions aboard *Independence* until her return to the States on 26 November.

**3-21 Dec 1962:** The squadron was aboard *Saratoga* (CVA 60) for carrier refresher training in the Caribbean and continued operations relating to the Cuban missile crisis.

**Dec 1963 and Jan-Feb 1964:** The squadron provided detachments of A-4C Skyhawks aboard *Intrepid* (CVS 11) and *Randolph* (CVS 15). The aircraft were used for Combat Air Patrol to provide a fighter capability for the ASW carriers.

**May-Dec 1967:** VA-34 deployed to Vietnam as a component of an Attack Carrier Air Wing (CVW-10) embarked in *Intrepid* (CVS-11). This was the squadron's first combat action since 1945.

### Home Port Assignments

Location	Assignment Date
NAS San Diego	15 Oct 1943*
NAS Atlantic City	16 Apr 1945
NAS Edenton	26 Jun 1945
NAS Elizabeth City	02 Nov 1945
NAAS Charlestown	11 Mar 1946
NAS Quonset Point	01 May 1947
NAAS Charlestown	26 Jun 1948
NAS Quonset Point	01 Dec 1949
NAAS Sanford	01 May 1951
NAS Jacksonville	06 Oct 1952
NAS Cecil Field	04 Feb 1953

\* During the squadron's Pacific tour from April 1944 to February 1945 it operated from numerous air and shore stations.

### Commanding Officers

	Date Assumed Command
LCDR Frederick E. Bakutis	15 Oct 1943
LCDR Herbert D. Remington	17 Apr 1945
LCDR T. W. Ramsay	11 Feb 1946
LCDR W. W. Brehm	28 Oct 1947
LCDR Thomas C. Provost, III	01 Jul 1948
LCDR Donald K. Olson	12 Dec 1949
LCDR Robert A. Sweatt	21 Feb 1951
LCDR H. B. Gibbs	01 May 1952
LCDR F. H. O'Brien	10 May 1953
CDR A. L. Detweiller (acting)	05 Jul 1955
CDR Charles W. Pittman	28 Oct 1955
CDR Ernest L. McClintock	Jan 1957
CDR George C. Talley, Jr.	07 Oct 1958
CDR Mitchell C. Griffin	11 Mar 1960
CDR William J. Forgy	26 May 1961
CDR Hector W. Davis, Jr.	29 May 1962
CDR Walter T. Zebrowski	05 May 1963
CDR Grant C. Young	05 May 1964
CDR Rodney B. Carter	05 May 1965
CDR Robert A. Zajichok	07 May 1966
CDR Richard A. Wigent	11 May 1967
CDR Mark E. Perrault	04 May 1968





The squadron's CO, Commander H. W. Davis, Jr., stands in front of the squadron's first A4D-2N (A-4C) Skyhawk.

**Aircraft Assignment**

Type of Aircraft	Date Type First Received
F6F-3	Oct 1943
F6F-5	Jul 1944
F8F-1	03 Apr 1946
F8F-2	03 Dec 1948
F9F-2	27 Nov 1950
F2H-2	14 Feb 1952
F7U-3	06 Oct 1955
A4D-1	Jan 1957
A4D-2	Nov 1958
A4D-2N/A-4C*	07 Jul 1962

\* A4D-2N designation was changed to A-4C in 1962.

A squadron F6F-5 Hellcat in flight, circa 1945 (Courtesy Robert Lawson Collection).



**Major Overseas Deployment**

Date of Departure	Date of Return	Air Wing	Carrier	Type of Aircraft	Area of Operation
16 Aug 1944*	21 Nov 1944	CVG-20	CV 6	F6F-3	WestPac
11 Dec 1944*	26 Jan 1945	CVG-20	CV 16	F6F-3	WestPac
20 Feb 1948	26 Jun 1948	CVAG-9	CV 47	F8F-1	Med
03 Sep 1951	20 Dec 1951	CVG-3	CV 32	F9F-2	Med
28 Aug 1952	04 Feb 1953	CVG-3	CVA 32	F2H-2	Med
30 Nov 1954	18 Jun 1955	ATG-181	CVA 15	F2H-2	Med
01 Feb 1958	01 Oct 1958	CVG-3	CVA 60	A4D-1	Med
15 Aug 1959	16 Feb 1960	CVG-3	CVA 60	A4D-2	Med
22 Aug 1960	25 Feb 1961	CVG-3	CVA 60	A4D-2	Med/NorLant
28 Nov 1961	12 May 1962	CVG-3	CVA 60	A4D-2	Med
29 Mar 1963	25 Oct 1963	CVG-3	CVA 60	A-4C	Med
28 Nov 1964	12 Jul 1965	CVW-3	CVA 60	A-4C	Med
11 Mar 1966	26 Oct 1966	CVW-3	CVA 60	A-4C	Med
11 May 1967	30 Dec 1967	CVW-10	CVS 11	A-4C	Med/IO/WestPac/ Vietnam
22 Jul 1968	29 Apr 1969	CVW-17	CVA 59	A-4C	Med

\* These deployment dates only cover the squadron's combat operations while staging out of Ulithi.



*Squadron F8F-1 Bearcats in flight, circa 1948 (Courtesy Robert Lawson Collection).*

### Air Wing Assignments

<i>Air Wing</i>	<i>Tail Code</i>	<i>Assignment Date</i>
CVG-20/CVAG-9/CVG-9*	PS	15 Oct 1943
CVG-3	K	01 Dec 1949
ATG-181		01 Nov 1953
CVG-3/CVW-3†	K/AC‡	18 Jun 1955
CVW-10	AK	01 Feb 1967§
CVW-17	AA	16 Jan 1968

\* Carrier Air Group 20 (CVG-20) was redesignated CVAG-9 on 15 November 1946 and was assigned the tail code PS on 12 December 1946. CVAG-9 was redesignated CVG-9 on 1 September 1948.

† Carrier Air Groups were redesignated Carrier Air Wings on 20 December 1963, hence, CVG-3 became CVW-3.

‡ CVG-3's tail code was changed from K to AC in the latter part of 1957. The effective date was most likely the beginning of FY 58 (1 July 1957).

§ CVW-3 records for 1967 list VA-46 being transferred from the air wing on 1 February 1967 but does not list VA-34. VA-34, as well as VA-46 and VA-103, were part of CVW-3 for the entire year of 1966, consequently, VA-34 probably was transferred from CVW-3 at the same time as VA-46 and VA-103, although such a transfer was not recorded in the air wing's history report.

### Unit Awards Received

<i>Unit Award</i>	<i>Inclusive Dates Covering Unit Award</i>	
NAVE	01 Jul 1948	30 Jun 1949
NUC	31 Aug 1944	18 Sep 1944
	10 Oct 1944	22 Nov 1944
	12 Jun 1967	08 Dec 1967
PUC	14 Dec 1944	16 Dec 1944
	03 Jan 1945	22 Jan 1945
AFEM	17 Jul 1958	25 Jul 1958
	29 Jul 1958	11 Aug 1958
RVNGC	19 Aug 1958	07 Sep 1958
	26 Oct 1962	18 Nov 1962
	18 Nov 1962	20 Nov 1962
	03 Dec 1962	20 Dec 1962
	21 Jun 1967	13 Jul 1967
VNSM	29 Jul 1967	27 Aug 1967
	14 Sep 1967	12 Oct 1967
	31 Oct 1967	24 Nov 1967
	14 Sep 1967	12 Oct 1967
	31 Oct 1967	24 Nov 1967
NEM	13 Apr 1961	26 Apr 1961



*Squadron F2H-2 Banshees on the deck of Randolph (CVA 15) during her cruise to the Med in 1954–1955.*

## THIRD VA-34

### Lineage

Established as Attack Squadron THIRTY FOUR (VA-34) on 1 January 1970. This is the third squadron to be designated VA-34.



When the third VA-34 squadron was established, it adopted this insignia which had been used by the second VA-34 squadron.

When VA-34 was established, it adopted the insignia and Blue Blasters nickname used by the previous VA-34 squadron (the second VA-34). Colors for the insignia are as follows: blue diamond background outlined in black, red stylized wings outlined in blue and white, black and white machine gun in the shape of a cigarette, with a yellow ammunition belt and red bullets, white skull and skeleton with black markings and outline, red teeth, and red markings on the paddles (eyes).

Nickname: Blue Blasters, 1970-present

### Chronology of Significant Events

**17 Apr 1970:** VA-34's establishment ceremony was conducted at NAS Oceana.

**18 Sep 1970:** The squadron boarded *Kennedy* (CVA 67) and departed on 14 September for final training and an Operational Readiness Inspection prior to its scheduled November deployment to the Mediterranean Sea. However, while en route to the Caribbean, the ship was ordered to deploy to the Mediterranean after Syria invaded Jordan.

**Sep 1972:** A squadron A-6 Intruder conducted cross-decking operations on HMS *Ark Royal* while operating in the Norwegian Sea.

**Oct-Nov 1973:** Due to the outbreak of war in the Middle East (Yon Kippur War), VA-34 and *Kennedy* departed the Norwegian Sea and reentered the Mediterranean, conducting surveillance operations south of Crete.

**Sep-Oct 1982:** During the deployment to the North Atlantic, *America* (CV 66), with VA-34 embarked, received orders on 22 September to proceed to the Mediterranean due to the continuing crisis in Lebanon.

**Jan and May 1983:** While in the Eastern Mediterranean the squadron conducted air operations from *America* in support of the multinational peace-keeping forces in Beirut, Lebanon.

### Squadron Insignia and Nickname

When VA-34 was established, it adopted the insignia and Blue Blasters nickname used by the previous VA-34 squadron (the second VA-34). Colors for the insignia are as follows: blue diamond background outlined in black, red stylized wings outlined in blue and white, black and

**Sep 1985:** While deployed aboard *America* to the North Atlantic, the squadron conducted flight operations from the carrier while it operated within Vestfjord, a Norwegian fjord.

**24 Mar 1986:** Libyan missiles were fired at U.S. Navy forces operating in the Gulf of Sidra. As a result of this hostile act retaliatory strikes, known as Operation Prairie Fire, were initiated against Libya by the American naval forces in the area. VA-34's A-6E Intruders, operating from *America*, attacked and damaged a Libyan Combattante II G-class fast attack missile craft with a Harpoon missile. A follow-up attack by VA-85 aircraft with Rockeye bombs resulted in the sinking of the Combattante II. The Harpoon firing was the first use of this missile in combat and the squadron's first combat action since its establishment in 1970.

**14 Apr 1986:** Due to continued Libyan sponsorship of terrorist activity the United States initiated Operation Eldorado Canyon. VA-34 participated in this operation with its A-6Es, conducting a night, low level high speed attack against terrorists targets at the Benina airfield and military barracks in Banghazi, Libya.

**Aug 1990:** The squadron flew missions in support of Operation Desert Shield, the build up of American and Allied forces to counter a threatened invasion of Saudi Arabia by Iraq and as part of an economic blockade of Iraq to force its withdrawal from Kuwait.

### Home Port Assignments

Location	Assignment Date
NAS Oceana	01 Jan 1970

### Commanding Officers

	Date Assumed Command
CDR Robert W. Miles	Feb 1970
CDR Samuel L. Sayers	25 Jun 1971
CDR Philip M. Shannon	Jul 1972
CDR Lester T. Jackson	28 Jul 1973
CDR William R. Westerman	19 Jul 1974
CDR Gary F. Wheatley	29 Oct 1975
CDR Robert H. Byng	03 Jan 1977
CDR John M. McNabb	21 Apr 1978
CDR John G. Hawley	03 Jul 1979
CDR Brinley K. McDanel	20 Oct 1980
CDR Bennice L. Liner	25 Nov 1981
CDR Garth A. Van Sickle	13 Feb 1983
CDR James B. Dadson	07 Aug 1984
CDR Richard G. Coleman	27 Jan 1986
CDR Bernis H. Bailey	05 Jun 1987
CDR Eugene K. Nielsen	04 Nov 1988
CDR Ronald K. Alexander	16 May 1990

**Aircraft Assignment**

<i>Total of Aircraft</i>	<i>Date Type First Received</i>
A-6A	17 Apr 1970
A-6B	May 1970
KA-6D	1971*
A-6C	1971†

**Aircraft Assignment—Continued**

<i>Total of Aircraft</i>	<i>Date Type First Received</i>
A-6E	Dec 1973
* The squadron received its first KA-6D sometime between April and June 1971.	
† The squadron received its first A-6C sometime between July and September 1971.	



*A squadron A-6E Intruder conducts operations off the coast of Norway in 1985.*

**Major Overseas Deployment**

<i>Date of Departure</i>	<i>Date of Return</i>	<i>Air Wing</i>	<i>Carrier</i>	<i>Type of Aircraft</i>	<i>Area of Operation</i>
14 Sep 1970	01 Mar 1971	CVW-1	CVA 67	A-6A/B	Carib/Med/ NorLant
01 Dec 1971	06 Oct 1972	CVW-1	CVA 67	A-6A/B/C & KA-6D	Med/NorLant
16 Apr 1973	01 Dec 1973	CVW-1	CVA 67	A-6A/B/C & KA-6D	Med/NorLant
28 Jun 1975	27 Jan 1976	CVW-1	CV 67	A-6E & KA-6D	Med
02 Sep 1976	09 Nov 1976	CVW-1	CV 67	A-6E & KA-6D	NorLant
15 Jan 1977	01 Aug 1977	CVW-1	CV 67	A-6E & KA-6D	Med
29 Jun 1978	08 Feb 1979	CVW-1	CV 67	A-6E & KA-6D	Med
04 Aug 1980	28 Mar 1981	CVW-1	CV 67	A-6E & KA-6D	Med
23 Aug 1982	30 Oct 1982	CVW-1	CV 66	A-6E & KA-6D	NorLant/Med/ Carib
08 Dec 1982	02 Jun 1983	CVW-1	CV 66	A-6E & KA-6D	Med/IO
24 Apr 1984	14 Nov 1984	CVW-1	CV 66	A-6E & KA-6D	Carib/Med/IO
24 Aug 1985	09 Oct 1985	CVW-1	CV 66	A-6E & KA-6D	NorLant
10 Mar 1986	10 Sep 1986	CVW-1	CV 66	A-6E & KA-6D	Med
29 Feb 1988	29 Aug 1988	CVW-7	CVN 69	A-6E & KA-6D	Med
08 Mar 1990	12 Sep 1990	CVW-7	CVN 69	A-6E & KA-6D	Med/Red Sea

**Air Wing Assignments**

<i>Air Wing</i>	<i>Tail Code</i>	<i>Assignment Date</i>
CVW-1	AB	02 Mar 1970
CVW-7	AG	01 Oct 1986

**Unit Awards Received**

<i>Unit Award</i>	<i>Inclusive Dates Covering Unit Award</i>	
MUC	29 Sep 1970	31 Oct 1970
	01 Dec 1977	01 Mar 1979
	29 Aug 1985	20 Sep 1985

**Unit Awards Received—Continued**

<i>Unit Award</i>	<i>Inclusive Dates Covering Unit Award</i>	
NAVE	01 Jan 1970	30 Jun 1971
	01 Jan 1982	31 Dec 1982
NEM	01 Jan 1983	20 Jan 1983
	06 May 1983	08 May 1983
	21 Mar 1986	27 Jun 1986
NUC	23 Mar 1986	17 Apr 1986
SLOC	04 Aug 1980	28 Mar 1981
	23 Aug 1982	02 Jun 1983
SASM	08 Aug 1990	24 Aug 1990



*A VA-34 A-6E makes a low-level strike at Vieques Island bombing range in the Caribbean in 1988.*

## VA-35

### Lineage

Established as Torpedo and Bombing Squadron TWO (VT-2) on 6 July 1925.

Redesignated Torpedo and Bombing Squadron TWO B (VT-2B) on 1 July 1927.\*

Redesignated Torpedo Squadron THREE (VT-3) on 1 July 1937.

Redesignated Attack Squadron FOUR A (VA-4A) on 15 November 1946.

Redesignated Attack Squadron THIRTY FIVE (VA-35) on 7 August 1948.

Disestablished on 7 November 1949. The first squadron to be assigned the VA-35 designation.

### Squadron Insignia and Nickname

The squadron's first insignia was a winged dragon holding the sun in its webbed foot. Several years later a bomb replaced the sun in the dragon's foot to symbolize the squadron's mission. The dragon's color was red, and was spitting fire from its mouth. There are no records indicating an approval date, however, there are references to the insignia in a newspaper published by *Saratoga* (CV 3).

*This was the first version of the dragon insignia used by the squadron. It dates from the mid-1920s.*

A modification to the original insignia was approved sometime in 1928 or 1929. The new insignia depicted a dragon astride a bomb. Colors for the dragon were red with a green spine, yellow claws and the tip of the tail in yellow. The bomb was black. When the squadron was redesignated in 1937 it continued to use this insignia.

During World War II the dragon took on a fatter, more stylized shape, however, the colors remained the same. There are no records indicating the squadron changed its insignia following its designation changes in the 1940s.

Nickname: unknown



*A more detailed version of the dragon insignia was adopted by the squadron in the late 1920s.*



*The final version of the dragon insignia was used by the squadron during World War II and into the postwar period.*

### Chronology of Significant Events

6 Jul 1925: VT-2 was established on board *Aroostook* (CM 3) at Pearl Harbor. *Aroostook* had been a minelayer that was refitted as an aircraft tender but continued to carry the CM minelayer designation.

Aug 1926: The squadron was engaged in experimental work relating to the use of signal lights as a means of communicating between aircraft and ships.

1928: With the arrival of the T3M-2 aircraft, the squadron began the transition from water based aircraft to land planes. The squadron continued its aircraft transition from T3M-2s, which were difficult to land on the carrier, to T4M-1s. Primary mission with the T4M-1s was bombing, although they could be used for torpedo work and laying smoke screens.

Jan-Feb 1929: Fleet Problem IX was the first time the Navy's two large carriers, *Saratoga* (with VT-2B embarked) and *Lexington* (CV 2), participated in a major fleet exercise.

Mar-Apr 1930: In March the squadron participated in Fleet Problem X which was conducted in the Caribbean Sea, followed by the Fleet Problem XI in April.

May 1930: VT-2B's aircraft joined with the planes from 9 other squadrons, which included the *Saratoga*, *Lexington*, and *Langley* Air Groups, for a three-day tour of east coast cities from Norfolk, Virginia to Boston. The flight was commanded by Captain Kenneth Whiting and consisted of 36 torpedo and bombing planes, 57 fighting planes, 24 scouting planes, 3 amphibian utility planes, 3 Ford trimotored transports



*A VT-2B T3M-2 with parachutists jumping from the wing, circa 1935.*

\* The squadron designation system was changed on 1 July 1930 by General Order 202 and Bombing was dropped from the designation Torpedo and Bombing Squadron. However, there was no change to the abbreviated squadron designation, it still remained VT.

and 2 staff planes. It was the largest air parade that had ever been assembled on the east coast.

**1931–1934:** The squadron participated in Fleet Problems XII through XV.

**31 May 1934:** A Fleet Review for President Franklin D. Roosevelt was held in New York Harbor.

**1935–1938:** The squadron participated in Fleet Problems XVI through XIX.

**May 1937:** VT-2B participated in the celebration marking the opening of the Golden Gate Bridge.

**Apr–May 1940:** The squadron participated in Fleet Problem XXI. This was the last major Fleet Problem conducted before America's involvement in World War II.

**May–Jun 1942:** VT-3, consisting primarily of its pilots, flight crews and a limited number of ground crewmen, operated from *Yorktown* (CV 5) during the Battle of Midway. The other officers and ground crews remained ashore at NAS Kaneohe. Shortly after noon on the 4th, Lieutenant Commander Massey led a flight of 12 TBD-1 Devastors into the attack against the Japanese carriers. They were the last of the three torpedo squadrons to engage the enemy. Only two aircraft survived, both flown by enlisted pilots. The two surviving TBDs returned to the task force while *Yorktown* was under attack from Japanese carrier aircraft. These two TBDs were ditched and their crews picked up by ships in the task force. VT-3's survivors from *Yorktown* returned to the squadron at NAS Kaneohe.

**4 Jun 1942:** Lieutenant Commander Massey was posthumously awarded the Navy Cross for his action during the battle. Eleven other squadron TBD pilots also were awarded the Navy Cross, they were Ensign Wesley F. Osmus, Ensign Carl A. Osberg, Lieutenant Patrick H. Hart, Enlisted Pilot Harry L. Corl, Enlisted Pilot Wilhelm G. Esders, Lieutenant (jg) Curtiss W. Howard, Ensign Leonard L. Smith, Enlisted Pilot John W. Haas, Ensign David J. Roche, Ensign Oswald A. Powers, and Lieutenant (jg) Richard W. Suesens.

**Aug 1942:** Operating from *Enterprise* (CV 6), VT-3 participated in the Battle of the Eastern Solomons.

**Nov 1942–Jul 1943:** VT-3 operated from *Saratoga*, flying combat missions against various Japanese held islands in the South Pacific and providing air cover for American forces operating in the Eastern Solomons. When the squadron was not operating from *Saratoga* it was based ashore at various places, including Fiji; Efate and Espiritu Santo, New Hebrides; Tontouta, New Caledonia, and Guadalcanal, Solomons.

**May 1943:** The British carrier HMS *Victorious* joined the *Saratoga* task force and operated with it until the latter part of July.

**31 Jul 1943:** VT-3's TBFs were transferred to Tontouta on 30 July and the following day squadron personnel embarked on HMS *Victorious* for transfer to CONUS to reform. This ended the air group and squadron's association with *Saratoga*.

**25 Sep 1943:** VT-3 and *Saratoga* Air Group were reformed at NAS Seattle. The *Saratoga* Air Group was reformed as Carrier Air Group THREE (CVG-3) with VT-3 as one of the three squadrons.

**Nov 1944:** VT-3 conducted combat operations from *Yorktown* (CV 10) against targets in the Philippines in support of the Leyte invasion.

**Dec 1944:** The squadron flew combat operations from *Yorktown* against targets on Luzon in preparation for the invasion of the island. While retiring from the combat area Task Force 38, which included *Yorktown* and CVG-3, sailed through a typhoon which sank three destroyers and extensively damaged other ships in the task force.

**Jan 1945:** Combat operations were conducted against targets in Formosa and the Philippines in support of the Lingayen Gulf landings on Luzon in early January. With *Yorktown* leading the way, Task Force 38 entered the South China Sea on 10 January. VT-3 struck targets near Saigon and along the Vietnamese coast, Hong Kong and Canton areas, Formosa and Okinawa.

**9 Jan 1945:** For actions against enemy targets on Formosa Lieutenant Frank F. Frazier was awarded the Silver Star.

**Feb 1945:** VT-3 participated in the first carrier strikes against the Tokyo area, bombing the Tachikawa Engine Factory, 16 miles from the Imperial Palace. Following these strikes the squadron concentrated its attention on Chichi Jima and air support for the invasion of Iwo Jima. This operation was the last combat action for the squadron during World War II. In early March VT-3 transferred to *Lexington* (CV 16) for transit to the States.

**Jun–Oct 1948:** During the squadron's tour of duty in the Mediterranean the Sixth Fleet was placed on alert due to the out break of war between Israel and the Arab countries following the establishment of the state of Israel.

**Nov 1948:** The squadron participated in cold weather operations in the Northern Atlantic.



This is a well-known photo of the squadron's T4M-1 making an approach on *Saratoga* (CV 3). Notice the squadron's dragon insignia on the fuselage just aft of the lower wing.

**Home Port Assignments**

<i>Location</i>	<i>Assignment Date</i>
<i>Aroostook</i> (CM 2)*	06 Jul 1925
NAS San Diego	Sep 1925
Ford Island (NAS Pearl Harbor)	Jan 1942†
NAS Kaneohe	03 Feb 1942‡
Efate	Aug 1942‡
Hawaii	Sep 1942†
NAS Seattle	Sep 1943
NAS Whidbey Island	11 Oct 1943
NAS Pasco	02 Feb 1944
NAS Alameda	05 Apr 1944†
NAS Puunene	22 Apr 1944†
NAS Hilo	07 Jun 1944†
NAS Kahului	22 Jul 1944†
NAS Seattle	Mar 1945
NAAF Lewiston	07 May 1945
NAS Key West	15 Jun 1945
NAAS Oceana	15 Jul 1945
NAS Quonset Point	11 Aug 1947
NAAS Charlestown	13 Oct 1947
NAS Quonset Point	21 Mar 1949

\* The ship was at NAS Pearl Harbor.

† Temporarily based ashore during World War II.

‡ When *Enterprise* (CV 6) was damaged by air attacks on 24 August, during the Battle of the Eastern Solomons, VT-3's surviving aircraft were flown to Efate. These aircraft remained at Efate while the majority of the squadron personnel went aboard *Saratoga* (CV 3) and returned to Hawaii in September 1942.

**Commanding Officers**

	<i>Date Assumed Command</i>
LT A. O. Rule, Jr.	06 July 1925
LT J. B. Kniep	Sep 1925
LCDR M. Griffin	Oct 1925
LCDR J. G. Strong	18 Jan 1926
LCDR J. B. Kniep	Jun 1926
CDR Read	Jul 1926
LCDR J. B. Kniep	Sep 1926
LT A. P. Schneider	Aug 1927
LCDR Harry R. Bogusch	Feb 1928
LCDR A. E. Montgomery	Jul 1929
LCDR William Masek	Jul 1930
LCDR J. L. Cotton	Mar 1931
LT T. C. Lonquest (acting)	Jun 1931
LCDR J. J. Ballentine	Jul 1931
LCDR Theodore C. Lonquest	Dec 1932
LCDR Harold J. Brow	May 1933
LCDR Herman E. Halland	Jun 1934
LCDR William H. Buracker	Jun 1936
LCDR Marion E. Crist	Jun 1937
LCDR Frank C. Sutton	27 Jun 1938
LT Austin V. Magly	28 May 1940
LT J. C. Clark	27 Jun 1941

**Commanding Officers—Continued**

	<i>Date Assumed Command</i>
LCDR John A. Collett	Jan 1942
LT John N. Myers (acting)	Jan 1942
LCDR Lance E. Massey	17 Apr 1942
LT John N. Myers (acting)	Jun 1942
LCDR Charles M. Jett	20 Jun 1942
LT John N. Myers (acting)	29 Dec 1942
LT Charles H. Turner (later LCDR)	Apr 1943
LT Roy S. Belcher, Jr. (later LCDR)	24 May 1945
LCDR Norman D. Johnson	Jan 1948
LCDR Roy P. Gee	24 Aug 1949



A squadron TG-2 with its dragon insignia on the fuselage, circa mid 1930s.

**Aircraft Assignment**

<i>Type of Aircraft</i>	<i>Date Type First Received</i>
DT-2*	Jul 1925
SC-2	Nov 1925
SC-1	Mar 1926
CS-1	Nov 1926
T2D-1	Jun 1927
T3M-2	Aug 1927
TB-1	Sep 1927
T4M-1	Jul 1928
TG-1	Jun 1930
TG-2	Apr 1932
TBD-1	05 Oct 1937
TBF-1	Jul 1942†
TBM-1C	15 Mar 1944
TBM-3E	Jun 1945
TBM-3Q	Jun 1946
TBM-3J	May 1947
TBM-3W	Sep 1947
AD-1	Apr 1949
AD-2	May 1949

\* The aircraft were on loan to the squadron from NAS Pearl Harbor.

† VT-3's shore detachment received its first TBF-1 in early May 1942. However, the squadron continued to operate the TBD-1s aboard the carrier until the latter part of July 1942 when it became an all TBF unit.





*A TBD-1 with VT-3 markings and the ever-present dragon insignia on the fuselage (Courtesy Harry Gann and the Douglas Collection).*

**Major Overseas Deployment**

<i>Date of Departure</i>	<i>Date of Return</i>	<i>Air Wing</i>	<i>Carrier</i>	<i>Type of Aircraft</i>	<i>Area of Operation</i>
15 Jan 1929	Mar 1929	<i>Saratoga</i> Air Group	CV 3	T4M-1	Canal Zone (Pac side)
15 Feb 1930	21 Jun 1930	<i>Saratoga</i> Air Group	CV 3	T4M-1	Canal Zone/ Carib
05 Feb 1931	15 Apr 1931	<i>Saratoga</i> Air Group	CV 3	TG-1	Canal Zone/ Carib
Feb 1932	19 Mar 1932	<i>Saratoga</i> Air Group	CV 2/3*	TG-1	Hawaii
23 Jan 1933	17 Feb 1933	<i>Saratoga</i> Air Group	CV 3	TG-2	Hawaii
09 Apr 1934	09 Nov 1934	<i>Saratoga</i> Air Group	CV 3/ CV 2†	TG-2	Canal Zone/ Carib & East Coast of U.S.
May 1935	Jun 1935	<i>Saratoga</i> Air Group	CV 3	TG-2	Hawaii/ NorPac
Apr 1936	Jun 1936	<i>Saratoga</i> Air Group	CV 3	TG-2	Canal Zone/ Pac
Apr 1937	May 1937	<i>Saratoga</i> Air Group	CV 3	TG-2	Hawaii/Pac
15 Mar 1938	Apr 1938	<i>Saratoga</i> Air Group	CV 3	TBD-1	Hawaii/Pac
02 Apr 1940	21 Jun 1940	<i>Saratoga</i> Air Group	CV 3	TBD-1	Hawaii/Pac
08 Dec 1941	Jan 1942	<i>Saratoga</i> Air Group	CV 3‡	TBD-1	Hawaii/Pac

**Major Overseas Deployment—Continued**

<i>Date of Departure</i>	<i>Date of Return</i>	<i>Air Wing</i>	<i>Carrier</i>	<i>Type of Aircraft</i>	<i>Area of Operation</i>
May 1942	Jun 1942	<i>Yorktown</i> Air Group	CV 5	TBD-1	Midway Island
15 Jul 1942	Aug 1942	<i>Enterprise</i> Air Group	CV 6	TBF-1	Pacific ops
10 Nov 1942	Jul 1943	<i>Saratoga</i> Air Group	CV 3§	TBF-1	Pacific ops
24 Oct 1944	27 Mar 1945	CVG-3	CV 10/ CV 16**	TBM-1C	Pacific ops
07 Jun 1947	11 Aug 1947	CVAG-3	CV 33	TBM-3E/Q & TBM-3J	NorLant/ Carib
01 Jun 1948	02 Oct 48	CVG-3	CV 33	TBM-3E/J & TBM-3W	Med

\* The squadron's cruise to Hawaii began aboard *Lexington* (CV 2) and prior to the beginning of Fleet Problem XXIII in late February it was transferred to *Saratoga*.

† During the squadron's 7 month deployment in 1934 VT-2B was divided into two divisions, with division 1 aboard *Saratoga* and division 2 aboard *Lexington*. VT-2B's division 2 operated with *Lexington's* Air Group.

‡ The squadron was operating from *Saratoga* in the Hawaiian area when the ship was hit by a torpedo from a Japanese submarine on 11 January 1942. *Saratoga* departed Hawaii and returned to Bremerton, Washington for repairs and VT-3 remained in Hawaii.

§ The squadron and air group transferred from *Saratoga* to HMS *Victorious* in July 1943 and returned to Hawaii aboard the British carrier. *Saratoga* remained in the South Pacific and continued her combat operations with a different air group embarked.

\*\* On 5 March 1945 VT-3 and CVG-3 were transferred from *Yorktown* to *Lexington* for its return to the States via Hawaii. *Lexington* departed Ulithi on 6 March, arriving in Hawaii on 17 March, departing on the 20th and arriving at Bremerton, Washington on 27 March.



*Squadron TBM-3 Avenger at NAAS Oceana in 1946 (Courtesy Robert Lawson Collection).*

**Air Wing Assignments**

<i>Air Wing</i>	<i>Tail Code</i>	<i>Assignment Date</i>
Aircraft Squadrons, Battle Fleet, <i>Aroostook</i> (CM 2)		06 Jul 1925
<i>Saratoga</i> Air Group*		09 Apr 1927
<i>Yorktown</i> Air Group†		May 1942
<i>Enterprise</i> Air Group		Jul 1942
<i>Saratoga</i> Air Group/ CVG-3/CVAG-3/CVG-3‡	K‡	Sep 1942

\* CNO's Assignment of Naval Aircraft (Naval Aeronautic Organization) for FY 27 (July 1927–June 1928) assigned VT-2B to *Saratoga* (CV 3) prior to the carrier's commissioning. Evolution of the *Saratoga* Air Group was as follows: *Saratoga* (CV 3) was commissioned 16 November 1927 with squadrons previously assigned; the squadrons assigned to the carrier were known as the *Saratoga* Air Group. However, it was not until 1 July 1938 when the Air Group Commander billets were established that the air group became an official organization.

† Temporarily assigned to *Yorktown* Air Group during the Battle of Midway.

‡ The tail code K was assigned to *Kearsarge* (CV 33) on 7 November 1946. Since CVG-3 was assigned to *Kearsarge* its

squadrons used the K tail code. On 12 December 1946 the tail code K was removed from *Kearsarge* and assigned to CVG-3.

§ *Saratoga* Air Group redesignated Carrier Air Group THREE (CVG-3) on 25 September 1943. The CVG-3 designation was changed to CVAG-3 on 15 November 1946 to show the air wing's association with an attack carrier. CVAG-3 was changed back CVG-3 on 1 September 1948 regardless of the air groups' assignment to an attack or battle carrier.

**Unit Awards**

<i>Unit Award</i>	<i>Inclusive Dates Covering Unit Award</i>	
PUC	11 Nov 1944	19 Nov 1944
	14 Dec 1944	16 Dec 1944
	03 Jan 1945	22 Jan 1945
	16 Feb 1945	25 Feb 1945
	23 Aug 1942	25 Aug 1942
Campaign Medal (Asiatic-Pacific)	Nov 1942	08 Feb 1943
	11 Nov 1944	19 Nov 1944
	14 Dec 1944	16 Dec 1944
	03 Jan 1945	22 Jan 1945
	16 Feb 1945	25 Feb 1945



*A squadron AD-1 trapping aboard Leyte (CV 32), November 1950 (Courtesy Duane Kasulka Collection).*

## SECOND VA-35

### Lineage

Established as Bombing Squadron THREE B (VB-3B) on 1 July 1934.

Redesignated Bombing Squadron FOUR (VB-4) on 1 July 1937.

Redesignated Bombing Squadron THREE (VB-3) on 1 July 1939.

Redesignated Attack Squadron THREE A (VA-3A) on 15 November 1946.

Redesignated Attack Squadron THIRTY FOUR (VA-34) on 7 August 1948.

Redesignated Attack Squadron THIRTY FIVE (VA-35) on 15 February 1950. The second squadron to be assigned the VA-35 designation.

### Squadron Insignia and Nickname



The original squadron diving panther insignia is one of the oldest squadron insignias in continuous use by a naval aviation command.

There is no record of official approval for the diving black panther insignia used by VB-3B. However, by mid-1935, the design appeared in Navy documents as Bombing THREE's insignia. The diving black panther design has been carried on through the various redesignations of the squadron and is the present insignia for VA-35. It was officially approved for VA-35 by CNO on 1 October 1957.

Nickname: Black Panthers.

### Chronology of Significant Events

May 1935: *Ranger* (CV 4) and her embarked air group, including VB-3B, participated in Fleet Exercise XVI. This was the first time VB-3B and *Ranger* participated in a Fleet Exercise.

25 Nov 1935–25 Feb 1936: A detachment from VB-3B, including six BG-1s, was assigned to *Ranger's* Cold Weather Test Detachment and operated aboard *Ranger* in Alaskan waters.

Apr–Jun 1936: The squadron participated in Fleet Problem XVII.

Apr–May 1937: The squadron participated in Fleet Problem XVIII.

28 May 1937: VB-3B participated in an aerial review celebrating the opening of the Golden Gate Bridge.

Jul 1937: The squadron, embarked in *Lexington* (CV 2), participated in the search for Amelia Earhart Putnam and Fred Noonan.

Sep 1937: VB-4, embarked in *Ranger*, visited Lima, Peru, in conjunction with the International Aviation Conference being held there.

Mar–Apr 1938: The squadron participated in Fleet Problem XIX.

Apr–May 1940: The squadron participated in Fleet Problem XXI. This was the last major fleet problem conducted before America's involvement in World War II.

Apr 1942: VB-3, embarked in *Enterprise* (CV 6), provided escort patrols for the task force which launched Colonel Doolittle's B-25 raid against Tokyo.

4 Jun 1942: At the Battle of Midway, VB-3, embarked in *Yorktown* (CV 5), engaged in its first combat operations. *Yorktown's* first strike included 17 SBD-3's from VB-3 led by Lieutenant Commander Leslie. Approximately an hour after launch, VB-3's aircraft sighted the Japanese Fleet and commenced their dive-bombing attack; the primary target was the carrier *Soryu*. Lieutenant (jg) Paul A. Holmberg was the first to drop his 1,000 pounder on the *Soryu*. His hit was followed by two more from VB-3's SBDs. *Soryu* erupted into flames and eventually sank.

With the *Soryu* in flames, the other VB-3 SBDs directed their attack against other targets. They attacked a destroyer, the *Isokaze*, making one hit on her fantail and "what appeared to be a battleship," claiming a hit on her stern. All 17 SBDs from VB-3 escaped the attack without a hit and returned to *Yorktown*. Prior to landing on the carrier, they were directed to leave the area due to incoming enemy aircraft. All VB-3's SBDs landed on *Enterprise* except for Lieutenant Commander Leslie and his wingman, Lieutenant (jg) Holmberg. These two men, low on fuel, ditched their aircraft along side the cruiser *Astoria* and were picked up by the ship's motor whaleboat.

The battle was still not over for VB-3. In late afternoon, 14 of VB-3's SBDs were launched from *Enterprise* as part of a strike group ordered to attack the fourth Japanese carrier, *Hiryu*. Lieutenant Shumway was in charge of VB-3's formation. The strike force located *Hiryu* and again caught a Japanese carrier in the vulnerable position of having armed and fueled planes on deck. Direct hits from Shumway's SBD's resulted in a torched *Hiryu* and her eventual sinking. Several of VB-3's aircraft suffered heavy damage from attacking Japanese aircraft. However, all but



The squadron's insignia with the scroll and designation added to the original design.

two of VB-3's aircraft returned to *Enterprise*. Seventeen of VB-3's pilots received the Navy Cross for their action during the Battle of Midway, they were Ensigns Benson, Butler, Campbell, Cobb, Cooner, Elder, Hanson, Isaman, Lane, Merrill and Schoegel; Lieutenant (jg)s Holmberg, Sherwood and Wiseman; Lieutenants Bottomley and Shumway; and Lieutenant Commander Leslie.

**Aug 1942:** While operating from *Saratoga* in the South Pacific, the squadron participated in strikes against Guadalcanal and other enemy installations in the Solomon Islands in support of the occupation of Guadalcanal.

**24 Aug 1942:** VB-3 participated in the Battle of the Eastern Solomons, attacking *Ryujo*, a Japanese light carrier, and helping to sink her.

**Jan–Jul 1943:** VB-3 operated in the South Pacific flying combat sorties against various Japanese-held islands and providing air cover for American forces.

**July 1943:** VB-3 and the *Saratoga* Air Group were relieved by Air Group 12 and boarded HMS *Victorious* for transfer to CONUS to reform, arriving at San Diego on 18 August. This ended the air group and VB-3's association with *Saratoga* (CV 3).

**Nov 1944:** VB-3 conducted combat operations from *Yorktown* (CV 10) against various targets, including shipping, in support of the Leyte invasion.

**Jan 1945:** Combat operations were conducted against targets in Formosa and the Philippines in support of the Lingayen Gulf landings on Luzon in early January. With *Yorktown* leading the way, Task Force 38 entered the South China Sea on 10 January. VB-3 struck targets near Saigon and along the Vietnamese coast, Canton and Hong Kong areas, Formosa and Okinawa.

**Feb 1945:** VB-3 participated in the first carrier strikes against the Tokyo area, bombing the Kasumiga-ura Airfield, an air depot 25 miles north of Tokyo, and the Tachikawa Aircraft Engine Plant, located 16 miles west of the Imperial Palace. Following these strikes, the squadron concentrated its attention on air support for the invasion of Iwo Jima. This operation was the last combat action for the squadron during World War II. On 6 March, the squadron transferred from *Yorktown* to *Lexington* (CV 16) for transfer to CONUS.

**11 Oct 1950:** While deployed to the Korean Theater aboard *Leyte* (CV 32), the squadron launched its first combat mission since February 1945, striking North Korean targets.

**12 Dec 1950:** The squadron's commanding officer, Lieutenant Commander Bagwell, crash-landed in North Korea and was taken prisoner.

**Jul–Aug 1958:** VA-35, along with other squadrons from CVG-3, provided support for U.S. Marines landing in Lebanon.

**Oct–Nov 1962:** VA-35 deployed to McCalla Field, Guantanamo Bay, Cuba, during the Cuban Missile

Crisis. During December, the squadron was embarked in *Saratoga* (CVA 60).

**4 Feb 1965:** The squadron's commanding officer, Commander Richard G. Laysler, was killed in an accident.

**15 Aug 1965:** VA-35 transferred from CVW-3 in preparation for its transition to the A-6A Intruder. This brought to a close an illustrious career with CVW-3 that began in 1939.

**26 Feb 1967:** The squadron participated in the first combat aerial mining operations since World War II, when its A-6A Intruders dropped mines in the Song Ca and Song Giang Rivers of North Vietnam.

**1 Oct 1967:** During a weapons training deployment to NAS Yuma, Arizona, VA-35 became the first A-6A squadron to fire the AIM-9 Sidewinder missile.

**Jan–Feb 1968:** While embarked in *Enterprise* (CVAN 65) and en route to Yankee Station, the carrier was ordered to the Sea of Japan for operations following the seizure of the *Pueblo* (AGER 2) by the North Koreans.

**12 Mar 1968:** The squadron's commanding officer, Commander Kollmann, was lost in an operational accident.

**17 Sep 1972:** While on a mission over North Vietnam the squadron's commanding officer, Commander Donnelly, was lost and is still listed as missing in action.

**3 Jan 1980:** VA-35 departed Naples, Italy, embarked in *Nimitz* (CVN 68), en route to the Indian Ocean via the Cape of Good Hope after the U.S. Embassy staff was taken hostage in Tehran, Iran. This was the beginning of 144 consecutive days at sea for the squadron.

**26 May 1981:** While on a training exercise aboard *Nimitz* off the coast of Charleston, S.C., an EA-6B from VMAQ-2 crashed into parked aircraft while attempting to land. VA-35 personnel provided firefighting support and assistance to the injured. There were no injuries to VA-35 personnel. Over 130 members of the squadron received awards for fighting fires and assisting the injured.

**Jun 1985:** *Nimitz* and VA-35 were ordered to operate off the coast of Lebanon due to the hijacking of TWA flight 847 by Arab radicals. The carrier and squadron remained on station until the release of the hostages in the latter part of June.

**Feb 1987:** VA-35, embarked in *Nimitz*, operated off the coast of Lebanon after three U.S. citizens were taken hostage from the American University in Beirut.

**Jul 1988:** VA-35 participated in a firepower demonstration for the Chairman of the Joint Chiefs of Staff and his guest, the Marshal of the Soviet Union.

**Sep 1988:** While deployed to the North Atlantic aboard *Theodore Roosevelt* (CVN 71), the squadron conducted flight operations from the carrier while in the Vestfjord of Norway.

**Aug–Dec 1990:** The squadron flew missions in sup-

port of Operation Desert Shield, the build-up of American and Allied forces to counter a threatened invasion of Saudi Arabia by Iraq and part of an economic blockade of Iraq to force its withdrawal from Kuwait.



*The BM-1 was the first type of aircraft operated by the squadron. The vertical fin of the aircraft was most likely painted willow green, indicating it was assigned to the Ranger air group.*

### Home Port Assignments

<i>Location</i>	<i>Assignment Date</i>
NAS Norfolk	01 Jul 1934
NAS San Diego	14 Apr 1935
Ford Island (NAS Pearl Harbor)*	Jan 1942
NAS Kaneohe*	Feb 1942
NAS Ewa*	Jun 1942
NAS Kaneohe*	Sep 1942
Nandi Field, Fiji Islands*	Nov 1942
Tontouta Airfield, New Caledonia*	Dec 1942
NAS Sand Point	Sep 1943
NAS Whidbey Island	Oct 1943
NAS Pasco	02 Feb 1944
NAS Alameda*	05 Apr 1944
NAS Puunene*	22 Apr 1944
NAS Hilo*	07 Jun 1944
NAS Kahului*	22 Jul 1944
NAS Seattle	28 Mar 1945
NAS Wildwood	07 May 1945
NAAS Oceana	19 Jul 1945
NAAS Charlestown	15 Apr 1947
NAS Quonset Point	14 Aug 1947
NAAS Charlestown	01 Oct 1947
NAS Quonset Point	01 Feb 1949
NAAS Oceana*	24 Aug 1950
NAS Quonset Point	03 Feb 1951
NAAS Sanford	30 Apr 1951
NAS Cecil Field	Feb 1953
NAS Jacksonville	01 Oct 1958
NAS Oceana	Aug 1965

\* Temporary shore base assignment during World War II.

### Commanding Officers

	<i>Date Assumed Command</i>
LCDR George C. Fairlamb, Jr.	01 Jul 1934
LCDR Robert H. Harrell	10 Jun 1935
LCDR Paul E. Roswall	05 Jun 1937
LCDR Edgar A. Cruise	Jul 1938
LCDR Robert E. Blick, Jr.	01 Jul 1939
LCDR Maxwell F. Leslie	1942
LCDR Dewitt W. Shumway	15 Jun 1942
LT Harold S. Bottomley, Jr	16 Apr 1943
LCDR John T. Lowe, Jr.	29 Sep 1943
LT Raymond S. Osterhoudt (acting)	22 Dec 1944
LT Raymond S. Osterhoudt	23 Feb 1945
LT. H. N. Murphy	07 May 1945
LCDR Heber J. Badger	04 Oct 1946
LCDR Ralph M. Bagwell	30 Nov 1948
LCDR John G. Osborn	19 Dec 1950
LCDR James W. Conger	31 Mar 1952
LCDR David G. Adams, Jr.	10 Aug 1953
CDR C. W. Johnson	Nov 1954
CDR Alfred E. Brown	Sep 1956
CDR Harlan W. Foote	07 Oct 1958
CDR William F. Bailey	21 Mar 1960
CDR E. C. Hastings II	28 Apr 1961
CDR W. F. Walker	29 May 1962
CDR J. R. Constantine	07 Mar 1963
CDR J. B. Allred	13 Mar 1964
CDR Richard G. Layser	22 Jan 1965
LCDR Joseph F. Frick (acting)	04 Feb 1965
CDR John W. Shute	22 Mar 1965
CDR Donald S. Ross	13 Aug 1965
CDR Arthur H. Barie	29 Jul 1966
CDR Glenn E. Kollmann	14 Jul 1967
CDR Herman L. Turk	15 Mar 1968
CDR Joseph F. Frick	29 May 1969
CDR Hugh J. Campbell	02 Jun 1970
CDR Kenneth B. Russell	12 Apr 1971
CDR Verne G. Donnelly	24 May 1972
CDR Milton D. Beach (acting)	17 Sep 1972
CDR Milton D. Beach	26 Sep 1972
CDR Gerald H. Hesse	21 Sep 1973
CDR Ronald P. Hyde	15 Aug 1974
CDR Brian K. Bryans	10 Dec 1975
CDR George D. O'Brien	31 Mar 1977
CDR James D. Joyner	23 Jun 1978
CDR John A. Pieno, Jr.	19 Jul 1979
CDR J. M. Luecke	05 Feb 1981
CDR A. H. White	24 Jun 1982
CDR Stephen A. Richmond	15 Dec 1983
CDR Ronald S. Pearson	24 Jun 1985
CDR Louis P. Lalli	24 Oct 1986
CDR James A. Bolcar	08 Apr 1988
CDR James B. Andersen	06 Sep 1989



One of the squadron's early aircraft, a BG-1, at Floyd Bennett Field, New York. Note the diving panther insignia on the fuselage. The squadron was assigned to the Ranger air group when this photo was taken.

**Aircraft Assignment**

Type of Aircraft	Date Type First Received
BM-1 and BM-2	Jul 1934
BG-1*	Nov 1934
SB2U-2	Jan 1938
SB2U-1	Jul 1940
BT-1	Mar 1941
SBC-4	Mar 1941
SBD-3	Aug 1941
SBD-4	Apr 1943
SBD-3P	Apr 1943
SBD-5	Aug 1943
SB2C-1C	Dec 1943
SBW-3	Jul 1944
SB2C-4	Sep 1944
SB2C-5	Jan 1946
AD-2	24 Nov 1948
AD-2Q	Feb 1949
AD-1	Feb 1949

**Aircraft Assignment—Continued**

Type of Aircraft	Date Type First Received
AD-4	Oct 1950
AD-3	May 1950
AD-4L	Feb 1951
AD-4B	Mar 1953
AD-4N	Aug 1953
AD-6/A-1H†	Sep 1953
AD-5	Oct 1954
A-6A	15 Dec 1965
A-6B	Jan 1968
KA-6D	Dec 1970
A-6C	Feb 1971
A-6E	19 Apr 1973

\* The XBG-1 was received by the squadron in October 1934, followed by the BG-1 production versions in November 1934.

† AD-6 designation changed to A-1H in 1962.



*A formation of the squadron's SB2U Vindicators. The squadron's diving panther insignia is barely visible on the fuselage of the aircraft.*

### **Major Overseas Deployment**

<i>Date of Departure</i>	<i>Date of Return</i>	<i>Air Wing</i>	<i>Carrier</i>	<i>Type of Aircraft</i>	<i>Area of Operation</i>
28 Mar 1935	15 Apr 1935	<i>Ranger</i> Air Group	CV 4	BG-1	Carib/Panama Canal/West Coast
May 1935	May 1935	<i>Ranger</i> Air Group	CV 4	BG-1	Hawaii
*	*	*	CV 4	BG-1	Alaska
27 Apr 1936	Jun 1936	<i>Lexington</i> Air Group	CV 2	BG-1	Central America/West Coast
Apr 1937	May 1937	<i>Lexington</i> Air Group	CV 2	BG-1	Hawaii
Mar 1938	Apr 1938	<i>Ranger</i> Air Group	CV 4	BG-2	Hawaii
02 Apr 1940	21 Jun 1940	<i>Saratoga</i> Air Group	CV 3	SB2U-2	Hawaii
08 Dec 1941	†Jan 1942	<i>Saratoga</i> Air Group	CV 3	SBD-3	Hawaii



**Major Overseas Deployment—Continued**

<i>Date of Departure</i>	<i>Date of Return</i>	<i>Air Wing</i>	<i>Carrier</i>	<i>Type of Aircraft</i>	<i>Area of Operation</i>
Apr 1942	Apr 1942	<i>Enterprise</i> Air Group	CV 6	SBD-3	Pacific Ops
30 May 1942	Jun 1942	<i>Yorktown</i> Air Group	CV 5‡	SBD-3	Battle of Midway
07 Jul 1942	21 Sep 1942	<i>Saratoga</i> Air Group	CV 3	SBD-3	SoPac
12 Nov 1942	26 Jul 1943	<i>Saratoga</i> Air Group	CV 3§	SBD-3	SoPac
24 Oct 1944	27 Mar 1945	CVG-3	CV 10/ CV 16**	SB2C-4	Pacific Ops
07 Jun 1947	11 Aug 1947	CVAG-3	CV 33	SB2C-5	NorLant/Carib
01 Jun 1948	02 Oct 1948	CVG-3	CV 33	SB2C-5	Med
02 May 1950	24 Aug 1950	CVG-3	CV 32	AD-3	Med
06 Sep 1950	18 Sep 1950	CVG-3	CV 32	AD-3	Carib/Panama Canal/West Coast
19 Sep 1950	03 Feb 1951	CVG-3	CV 32	AD-3/4	WestPac/ Korea
03 Sep 1951	21 Dec 1951	CVG-3	CV 32	AD-4/L	Med
29 Aug 1952	Feb 1953	CVG-3	CVA 32	AD-4	Med
12 Nov 1953	Sep 1954	CVG-3	CVA 40	AD-6	World Cruise
04 Nov 1955	02 Aug 1956	CVG-3	CVA 14	AD-6	Med
01 Feb 1958	01 Oct 1958	CVG-3	CVA 60	AD-6	Med
16 Aug 1959	26 Feb 1960	CVG-3	CVA 60	AD-6	Med
22 Aug 1960	26 Feb 1961	CVG-3	CVA 60	AD-6	NorLant/Med
28 Nov 1961	11 May 1962	CVG-3	CVA 60	AD-6	Med
29 Mar 1963	25 Oct 1963	CVG-3	CVA 60	AD-6	Med
28 Nov 1964	12 Jul 1965	CVW-3	CVA 60	A-1H	Med
19 Nov 1966	06 Jul 1967	CVW-9	CVAN 65	A-6A	WestPac/Vietnam
03 Jan 1968	18 Jul 1968	CVW-9	CVAN 65	A-6A/B	WestPac/Vietnam
23 Sep 1969	01 Jul 1970	CVW-15	CVA 43	A-6A	WestPac/Vietnam
06 Jul 1971	16 Dec 1971	CVW-8	CVA 66	A-6A/B/C & KA-6D	Med
05 Jun 1972	24 Mar 1973	CVW-8	CVA 66	A-6A/C & KA-6D	WestPac/Vietnam
03 Jan 1974	03 Aug 1974	CVW-8	CVA 66	A-6E & KA-6D	Med
06 Sep 1974	12 Oct 1974	CVW-8	CVA 66	A-6E & KA-6D	NorLant
16 Jul 1975	24 Sep 1975	CVW-8	CVN 68	A-6E & KA-6D	Carib/NorLant
07 Jul 1976	07 Feb 1977	CVW-8	CVN 68	A-6E & KA-6D	Med
01 Dec 1977	20 Jul 1978	CVW-8	CVN 68	A-6E & KA-6D	Med/ NorLant
10 Sep 1979	26 May 1980	CVW-8	CVN 68	A-6E & KA-6D	Med/SoLant/ IO
29 Aug 1980	17 Oct 1980	CVW-8	CVN 68	A-6E & KA-6D	NorLant
03 Aug 1981	12 Feb 1982	CVW-8	CVN 68	A-6E & KA-6D	Med
10 Nov 1982	20 May 1983	CVW-8	CVN 68	A-6E & KA-6D	Carib/Med

**Major Overseas Deployment—Continued**

<i>Date of Departure</i>	<i>Date of Return</i>	<i>Air Wing</i>	<i>Carrier</i>	<i>Type of Aircraft</i>	<i>Area of Operation</i>
08 Mar 1985	04 Oct 1985	CVW-8	CVN 68	A-6E & KA-6D	Carib/Med
15 Aug 1986	16 Oct 1986	CVW-8	CVN 68	A-6E & KA-6D	NorLant
30 Dec 1986	26 Jul 1987	CVW-8	CVN 68	A-6E & KA-6D	Med/SoLant/ West Coast
25 Aug 1988	11 Oct 1988	CVW-8	CVN 71	A-6E	NorLant
30 Dec 1988	30 Jun 1989	CVW-8	CVN 71	A-6E	Med
07 Aug 1990	28 Mar 1991	CVW-17	CV 60	A-6E & KA-6D	Med/Red Sea

\* Detachments from Aircraft Squadrons, Battle Fleet, including a detachment from VB-3B, were organized as *Ranger's* Cold Weather Test Detachment and operated on a northern cruise to Alaska sometime between late November 1935 and 25 February 1936.

† The squadron was operating from *Saratoga* in the Hawaiian area when the ship was hit by a torpedo from a Japanese submarine on 11 January 1942. *Saratoga* departed Hawaii for repairs at Bremerton, Washington, and VB-3 remained in Hawaii.

‡ After the squadron's first strike against the Japanese carriers, it operated from *Enterprise* (CV 6) for the remainder of the Midway battle.

§ While deployed to the South Pacific, as part of the *Saratoga* Air Group, the squadron operated from *Saratoga* and various shore stations in New Caledonia, Fiji Islands, and Solomon Islands.

\*\* On 5 March 1945, VB-3 and CVG-3 were transferred from *Yorktown* (CV 10) to *Lexington* (CV 16) for its return to CONUS via Hawaii. *Lexington* departed Ulithi on 6 March, arriving in Hawaii on 17 March, departing on the 20th and arriving at Bremerton, Washington, on 27 March.



The squadron's SBD Dauntlesses are in the foreground on the deck of *Saratoga* (CV 3), circa late 1941. In the background are F4F Wildcats and TBD Devastators from *Saratoga's* air group.



*SB2C-4 Helldivers from VB-3 fly over the invasion fleet at Iwo Jima en route to bomb targets on the island, 22 February 1945.*

**Air Wing Assignments**

<i>Air Wing</i>	<i>Tail Code</i>	<i>Assignment Date</i>
Ranger Air Group*		01 Jul 1934
Lexington Air Group*		Nov 1935
Ranger Air Group		01 Jul 1937
Saratoga Air Group		01 Jan 1939
Yorktown Air Group		May 1942
Saratoga Air Group/ CVG-3/CVAG-3/ CVG-3/CVW-3†	K/AC‡	Jun 1942
CVW-4		15 Aug 1965
COMFAIRNORFOLK		16 Dec 1965
CVW-9	NG	22 Sep 1966
COMFAIRNORFOLK		Jul 1968
CVW-15	NL	31 Jul 1969
COMFAIRNORFOLK		01 Jul 1970
CVW-8	AJ	01 Jan 1971
CVW-17	AA	07 Sep 1989

\* *Ranger* (CV 4) was commissioned on 4 June 1934 and VB-3B was assigned to *Ranger* on 1 July 1934. Squadrons assigned to the carri-



*A squadron AD-6 (A-1H) Skyraider, circa late 1950s or early 1960s.*

ers prior to 1 July 1938 were part of that carrier's air group. However, it was not until after 1 July 1938, when Air Group Commander billets were established, that the air group became an official organization.

† The *Saratoga* Air Group was redesignated Carrier Air Group THREE (CVG-3) on 25 September 1943. The CVG-3 designation was changed to CVAG-3 on 15 November 1946 to show the air wing's association with an attack carrier. It was changed back to CVG-3 on 1 September 1948 and no longer indicated the air group's association to a particular carrier designation, such as attack or battle carrier. On 20 December 1963, all Carrier Air Groups (CVG) were redesignated Carrier Air Wings (CVW).

‡ The tail code K was assigned to *Kearsarge* (CV 33) on 7 November 1946. Since CVG-3 was assigned to *Kearsarge*, its squadrons used the K tail code. On 12 December 1946, the tail code K was removed from *Kearsarge* and assigned to CVG-3. Carrier Air Group 3's tail code was changed from K to AC in the latter part of 1957. The effective date was most likely the beginning of FY 58 (1 July 1957).

**Unit Awards Received**

<i>Unit Award</i>	<i>Inclusive Dates Covering Unit Award</i>	
PUC	11 Nov 1944	19 Nov 1944
	14 Dec 1944	16 Dec 1944
	03 Jan 1945	22 Jan 1945
	01 Jul 1971	31 Dec 1972
NAVE	01 Oct 1976	30 Sep 1977
	01 Oct 1978	30 Sep 1979
	01 Oct 1980	31 Dec 1981
	01 Jan 1983	31 Dec 1983
	01 Jan 1987	31 Dec 1987
PUC	11 Nov 1944	19 Nov 1944
	14 Dec 1944	16 Dec 1944
	03 Jan 1945	22 Jan 1945
KPUC	16 Feb 1945	25 Feb 1945
	05 Oct 1950	19 Jan 1951
NUC	09 Oct 1950	19 Jan 1951
	18 Dec 1966	20 Jun 1967
MUC	22 Feb 1968	26 Jun 1968
	23 Jan 1980	01 May 1980
	17 Jan 1991	28 Feb 1991
	27 Oct 1969	01 Jun 1970
	14 Jul 1972	20 Feb 1973
	01 Dec 1977	21 Dec 1979
	01 Jan 1981	12 Feb 1982
	23 Jan 1968	22 Mar 1968
	10 Dec 1969	11 Dec 1969
	18 Oct 1962	23 Oct 1962
RVNGC	14 Jan 1980	14 May 1980
	05 Dec 1982	31 Dec 1982
	21 Jan 1983	13 Feb 1983
	18 Feb 1983	24 Feb 1983
	19 Mar 1983	21 Mar 1983
	18 Apr 1983	22 Apr 1983
	22 Feb 1968	24 Feb 1968
	26 Feb 1968	03 Mar 1968
	05 Mar 1968	08 Mar 1968
	12 Mar 1968	
13 Mar 1968		

**Unit Awards Received—Continued**

<i>Unit Award</i>	<i>Inclusive Dates Covering Unit Award</i>	
	14 Mar 1968	
	16 Mar 1968	
	29 Mar 1968	30 Mar 1968
	01 Apr 1968	05 Apr 1968
	07 Apr 1968	10 Apr 1968
	12 Apr 1968	
	14 Apr 1968	
	16 Apr 1968	20 Apr 1968
	22 Apr 1968	23 Apr 1968
	02 May 1968	
	01 Jun 1968	02 Jun 1968
	04 Jun 1968	
	15 Jun 1968	
	16 Aug 1968	10 Sep 1968
VNSM	19 Dec 1966	17 Jan 1967
	31 Jan 1967	03 Mar 1967
	20 Mar 1967	18 Apr 1967
28 Apr 1967	28 May 1967	
	04 Jun 1967	21 Jun 1967
	21 Feb 1968	17 Mar 1968
	26 Mar 1968	24 Apr 1968
	30 Apr 1968	21 May 1968
	30 May 1968	27 Jun 1968

**Unit Awards Received—Continued**

<i>Unit Award</i>	<i>Inclusive Dates Covering Unit Award</i>	
	26 Oct 1969	18 Nov 1969
	22 Dec 1969	19 Jan 1970
	17 Feb 1970	09 Mar 1970
	19 Mar 1970	11 Apr 1970
	28 Apr 1970	01 Jun 1970
	02 Jul 1972	04 Jul 1972
	11 Jul 1972	24 Jul 1972
	10 Aug 1972	28 Aug 1972
	06 Sep 1972	07 Oct 1972
	11 Oct 1972	12 Oct 1972
	20 Oct 1972	01 Dec 1972
	09 Dec 1972	27 Dec 1972
	09 Jan 1973	02 Feb 1973
	12 Feb 1973	16 Feb 1973
	21 Feb 1973	25 Feb 1973
KLM	17 Jan 1991	07 Feb 1991
SASM	22 Aug 1990	21 Sep 1990
	23 Oct 1990	09 Dec 1990
	06 Jan 1991	11 Mar 1991
Campaign Medal	(Asiatic-Pacific) For numerous periods during World War II.	



*A squadron A-6 Intruder with its famous diving panther insignia on the tail.*

## VA-36

### Lineage

Established as Fighter Squadron ONE HUNDRED TWO (VF-102) on 1 May 1952.

Redesignated Attack Squadron THIRTY SIX (VA-36) on 1 July 1955.

Disestablished on 1 August 1970. The first squadron to be designated VA-36.

### Squadron Insignia and Nickname

VF-102's first insignia was approved by CNO in October 1952. Unfortunately, the squadron's insignia file does not contain a drawing or photograph of the design. The insignia included: a blue circular design with a black winged wolf leaping diagonally from left to right in front of a yellow moon and over a red lightning bolt; and a blue sea depicted in the lower part of the circle. The wolf, lightning bolt, blue sea and circular insignia were outlined in yellow.



*It is believed the squadron adopted the roadrunner insignia sometime after receiving its first A-4 Skyhawks. One of the nicknames for the A-4 was "Heinemann's Hot Rod" and the logo on the insignia may be indicative of that nickname.*

However, there is no indication when it was approved or used by the squadron. Colors for the roadrunner insignia were: a green background outlined in yellow; and a gray roadrunner with blue wings and head feathers, a yellow beak, red tongue and white legs holding white rockets with red tips. The insignia's upper and lower scrolls had a blue background with Attack Squadron 36 in white on the upper and Hotrodus Supersonic in white on the lower. Both scrolls were outlined in yellow.

Nickname: Roadrunners, timeframe unknown.

### Chronology of Significant Events

Nov 1953-Sep 1954: During the squadron's world cruise aboard *Tarawa* (CVA 40), it visited 14 different ports in 10 foreign countries and transited the Suez and Panama Canals.

Jul-Aug 1961: While deployed on a training cruise aboard *Saratoga* in the Caribbean, the squadron was on an alert status due to the Bay of Pigs invasion.

2 Dec 1965: The squadron conducted its first combat operations, flying from *Enterprise* (CVAN 65) on

Dixie Station in the South China Sea off the coast of Vietnam. This marked the first time a nuclear powered ship had engaged in combat.

Dec 1965-Jun 1966: During this period of combat operations squadron personnel were awarded over 170 Air Medals.

May-Jun 1967: VA-36, embarked on *America*, was on station in the eastern Mediterranean during the Middle East War between Israel and Egypt and Syria. Units of *America's* air wing were launched to provide air cover for *Liberty* (AGTR 5) when it came under attack by Israeli forces.

### Home Port Assignments

Location	Assignment Date
NAAS Cecil Field	01 May 1952
NAS Jacksonville	Jul 1955
NAS Cecil Field	Apr 1956

### Commanding Officers

	Date Assumed Command
LCDR R. B. Dalton	01 May 1952
CDR R. A. Clarke	1953
CDR L. A. Menard, Jr.	10 Sep 1954
CDR Thad T. Coleman, Jr.	31 May 1956
CDR Hugh M. Garvey	26 Jul 1957
CDR A. L. Detweiler	22 Jul 1958
LCDR P. D. Davidson	30 Jan 1960
CDR G. L. Ayers, Jr.	28 Apr 1961
CDR E. J. Carroll	29 May 1962
CDR H. K. Matthes	18 May 1963
CDR R. W. Somers	01 May 1964
CDR J. E. Marshall	22 Apr 1965
CDR T. F. Rush	02 Apr 1966
CDR A. R. Cunningham	19 May 1967
CDR E. H. Brooks	24 May 1968
CDR N. H. Rose	29 May 1969
CDR W. C. Nix	30 Mar 1970

### Aircraft Assignment

Type of Aircraft	Date Type First Received
FG-1D	May 1952
F9F-5	Oct 1952
F9F-8 & F9F-8B	02 Nov 1956
F9F-8T	14 Apr 1957
A4D-2	11 Sep 1958
A4D-2N/A-4C*	21 Mar 1961
A-4E†	Oct 1967

\* The A4D-2N designation changed to A-4C in 1962.

† The squadron began its transition to A-4Es in October 1967 and in November 1967 transitioned back to A-4Cs.



*In the background is a squadron F9F-5 Panther and the pilots who night carrier qualified aboard Bennington (CVA 20) in September 1955 prior to the squadron's WestPac deployment on the carrier. VA-36 pilots are: Bottom row, left to right: Lt. K. T. Weaver; Lt. P. M. McGucken, Cdr. L. A. Mendar, Jr., CO; Cdr. T. T. Coleman, Jr., XO; and LCdr. R. G. Altman. Top row, left to right: Lt. (jg) D. R. Fall, Lt. P. E. Johnson, Lt. (jg) D. A. Brown, Lt. (jg) A. J. Cooper, Lt. R. C. Doan, Lt. (jg) B. J. Gordon, Lt. T. W. Lockett, Ens. G. V. Smith, Lt. (jg) H. L. Brooks, Lt. H. A. Lackey II, Lt. A. J. Kermes, Lt. (jg) H. W. Neubard, Lt. (jg) W. D. Baker, Lt. (jg) M. N. Guess, Ens. L. Ames (AIO), Lt. (jg) R. C. Scott, Lt. J. D. Blackwood, Lt. (jg) J. B. Busey and Lt. (jg) M. E. Hill.*

### **Major Overseas Deployment**

<i>Date of Departure</i>	<i>Date of Return</i>	<i>Air Wing</i>	<i>Carrier</i>	<i>Type of Aircraft</i>	<i>Area of Operation</i>
Nov 1953	Sep 1954	CVG-3	CVA 40	F9F-5	World Cruise
31 Oct 1955	16 Apr 1956	ATG-201	CVA 20	F9F-5	WestPac
15 Aug 1959	26 Feb 1960	CVG-3	CVA 60	A4D-2	Med
22 Aug 1960	26 Feb 1961	CVG-3	CVA 60	A4D-2	NorLant/Med
05 Jul 1961	22 Aug 1961	CVG-3	CVA 60	A4D-2N	Carib
28 Nov 1961	11 May 1962	CVG-3	CVA 60	A4D-2N	Med
03 Dec 1962	21 Dec 1962	CVG-3	CVA 60	A4D-2N	Carib
29 Mar 1963	25 Oct 1963	CVG-3	CVA 60	A-4C	Med
28 Nov 1964	12 Jul 1965	CVW-3	CVA 60	A-4C	Med
26 Oct 1965	21 Jun 1966	CVW-9	CVAN 65	A-4C	SoLant/IO/ WestPac/ Vietnam
10 Jan 1967	20 Sep 1967	CVW-6	CVA 66	A-4C	Med
04 Jun 1968	08 Feb 1969	CVW-10	CVS 11	A-4C	SoLant/IO/ Pacific/Vietnam
02 Dec 1969	08 Jul 1970	CVW-17	CVA 59	A-4C	Med

**Air Wing Assignments**

<i>Air Wing</i>	<i>Tail Code</i>	<i>Assignment Date</i>
CVG-10	P	01 May 1952
CVG-3	K	Nov 1953
CVG-10	P	Sep 1954
ATG-201	J/AP*	May 1955†
ATG-202	AQ	15 Jan 1958
CVG-17	AL	14 Mar 1958
CVG-3/CVW-3‡	AC	11 Oct 1958
CVW-9	NG	22 Sep 1965
CVW-8	AJ	15 Jul 1966
CVW-6	AE	01 Sep 1966
CVW-10	AK	16 Oct 1967
CVW-17	AA	01 Aug 1969

\* The tail code J was assigned to ATG-201 on 24 July 1956 and changed to AP in the latter part of 1957. The effective date for the change was most likely the beginning of FY 58 (1 July 1957).

† The specific date the squadron was assigned to Air Task Group 201 (ATG-201) has not been verified. However, it probably was in May 1955, the date the squadron deployed aboard *Bennington* (CVA 20) for a shakedown cruise to Guantanamo Bay.

‡ Carrier Air Groups were redesignated Carrier Air Wings on 20 December 1963, hence, CVG-3 became CVW-3.

**Unit Awards Received—Continued**

<i>Unit Award</i>	<i>Inclusive Dates Covering Unit Award</i>	
NEM	07 Jul 1961	19 Aug 1961
RVNGC	02 Dec 1965	
	11 Dec 1965	
	21 Dec 1965	
	24 Dec 1965	
	26 Dec 1965	30 Dec 1965
	01 Jan 1966	02 Jan 1966
	04 Jan 1966	14 Jan 1966
	04 Feb 1966	
	19 Feb 1966	
	23 Feb 1966	
	27 Mar 1966	28 Mar 1966
	30 Mar 1966	31 Mar 1966
	02 Apr 1966	
	11 Apr 1966	
	29 Apr 1966	
	01 Oct 1968	01 Nov 1968
VNSM	02 Dec 1965	14 Jan 1966
	04 Feb 1966	23 Feb 1966
	16 Mar 1966	12 Apr 1966
	22 Apr 1966	14 May 1966
	23 May 1966	06 Jun 1966
	11 Jul 1968	12 Jul 1968
	14 Jul 1968	15 Jul 1968
	23 Jul 1968	22 Aug 1968
	14 Oct 1968	14 Nov 1968
	03 Dec 1968	27 Dec 1968
NUC	06 Jul 1968	16 Jan 1969

**Unit Awards Received**

<i>Unit Award</i>	<i>Inclusive Dates Covering Unit Award</i>	
NAVE	Jul 1958	Jun 1959
	01 Jan 1967	30 Jun 1968
AFEM	03 Dec 1962	20 Dec 1962



*Squadron A-4C Skyhawks assigned to CVW-9 deployed aboard Enterprise (CVAN 65).*

## SECOND VA-36

### Lineage

Established as Attack Squadron THIRTY SIX (VA-36) on 6 March 1987.

Disestablished on 1 April 1994. The second Navy squadron to be assigned the VA-36 designation.

### Squadron Insignia and Nickname

The insignia adopted by VA-36 is a modification of the Roadrunner insignia used by the first VA-36



The squadron adopted a roadrunner insignia similar to the first VA-36 squadron.

squadron. The old insignia had been a Roadrunner cartoon character, but the modification depicted a real bird with its primary enemy clutched in its talons. Colors for the insignia are: blue background and scrolls; silver and black bird with a red eye and tongue; yellow snake with black markings; and red lettering in the scrolls.

VA-36's insignia was tentatively approved by CNO on 6 April 1987.

Nickname: Roadrunners, 1987–1994.

### Chronology of Significant Events

**30 Dec 1988:** VA-36 deployed aboard *Theodore Roosevelt* (CVN 71) for the carrier's maiden cruise to the Mediterranean Sea.

**20 Jan–28 Feb 1991:** The squadron participated in Operation Desert Storm, combat operations against Iraq.

**Apr–Jun 1991:** The squadron participated in Operation Provide Comfort, a multi-national operation providing relief and aid for Kurdish refugees in northern Iraq.

**Mar–Sep 1993:** The squadron, along with other units of CVW-8, deployed aboard *Roosevelt* (CVN 71) in a new approach to joint operations to test the Navy's ability to project a wide range of power and mobility from the sea. The composition on the carrier during the deployment included the regular air wing, minus an F-14 and S-3 squadron, and a Special Marine Air-Ground Task Force consisting of a Marine Corps fixed-wing and helo squadron and a company of Marines. The mix of units provided the carrier with the ability to project air and ground striking power ashore from a single deck.

**Jun 1993:** The squadron, along with other units embarked on *Theodore Roosevelt* (CVN 71), operated in the Red Sea in support of a strike on the Iraqi Intelligence Service headquarters building in Baghdad in response to Iraq's attempt on the life of former President Bush while on a visit to Kuwait in April. During this time, the squadron also participated in Operation Southern Watch missions, enforcing the U. N. no-fly zone within southern Iraq.

### Home Port Assignments

	<i>Location Assignment Date</i>
NAS Oceana	06 Mar 1987

### Commanding Officers

	<i>Date Assumed Command</i>
CDR T. Lamar Willis	06 Mar 1987
CDR Daniel J. Franken	01 Dec 1988
CDR T. Ladson Webb, Jr.	04 May 1990
CDR Thomas M. Deyke	27 Aug 1991
CDR Mark T. McNally	03 Sep 1992
CDR Mark J. Himler	23 Sep 1993

### Aircraft Assignment

<i>Type of Aircraft</i>	<i>Date Type First Received</i>
A-6E	May 1987

### Major Overseas Deployment

<i>Date of Departure</i>	<i>Date of Return</i>	<i>Air Wing</i>	<i>Carrier</i>	<i>Type of Aircraft</i>	<i>Area of Operation</i>
25 Aug 1988	11 Oct 1988	CVW-8	CVN 71	A-6E	NorLant
30 Dec 1988	30 Jun 1989	CVW-8	CVN 71	A-6E	Med
28 Dec 1990	28 Jun 1991	CVW-8	CVN 71	A-6E	Med/IO
11 Mar 1993	08 Sep 1993	CVW-8	CVN 71	A-6E	Med/IO



**Air Wing Assignments**

<i>Air Wing</i>	<i>Tail Code</i>	<i>Assignment Date</i>
CVW-8	AJ	Sep 1987

**Unit Awards Received**

<i>Unit Award</i>	<i>Inclusive Dates Covering Unit Award</i>	
NUC	17 Jan 1991	07 Feb 1991
SASM	14 Jan 1991	20 Apr 1991
JMUA	05 Apr 1991	16 Jul 1991
MUC	01 Mar 1993	01 Aug 1993



*A squadron A-6E Intruder on a mission over the northern Arabian Gulf during Operation Desert Storm. Note the cluster bombs on the wing pylons.*

## **VA-38**

### ***Lineage***

Established as Attack Squadron THIRTY EIGHT (VA-38) on 1 March 1967.

Disestablished on 1 October 1968. The first and only squadron to be assigned the VA-38 designation.

### ***Chronology of Significant Events***

The establishment of VA-38 was directed by CNO.

The squadron's administrative assignment was to Commander Fleet Air, Jacksonville. However, it appears VA-38 existed only on paper. The squadron was established while the A-7A Corsair II was being introduced to the fleet and may have been programmed to be a new A-7A attack squadron. However, according to the CNO publication, *Allowances and Location of Navy Aircraft*, the squadron was not assigned aircraft. The only records on the squadron are the CNO messages establishing and disestablishing the unit.

## VA-42

### Lineage

Established as Fighter Squadron FORTY TWO (VF-42) on 1 September 1950.

Redesignated Attack Squadron FORTY TWO (VA-42) on 1 November 1953.

Disestablished on 30 September 1994. The first squadron to be assigned the VA-42 designation.

### Squadron Insignia and Nickname

The insignia for VA-42, the green pawn, was originally approved by CNO for Bombing and Fighting Squadron 75 (VBF-75) on 28 October 1946. When VBF-75 was redesignated VF-4B on 15 November 1946, the insignia was carried over for use by Fighting Squadron 4B (VF-4B). On 1 September 1948 VF-4B was redesignated Fighting Squadron 42 (VF-42). This squadron continued to use the green pawn insignia until it was disestablished on 8 June 1950.

When a new Fighting Squadron 42 (VF-42) was established on 1 September 1950 they adopted the green pawn insignia that had been used by the former VF-42. In 1953 the insignia was carried over to VA-42 following its redesignation from VF-42.

The green pawn insignia is a simple, uncluttered and highly recognizable design. The symbol of the pawn was chosen because it has the most potential power of any piece on the chess board. The pawn is canted at a 45 degree angle inside a shield design.

Colors are as follows: green pawn; background of the shield is white outlined in green; and the scroll is white outlined in green with green lettering.

A new insignia was approved for the squadron by CNO on 19 October 1992. The new insignia design had been used by VA-176 until it was disestablished. Colors for the mailed fist and lightning

bolt were: a blue background and scroll outlined in white; the mailed fist was outlined in white with a blue background; white stars; yellow lightning bolt; and the lettering was white.

Nickname: Green Pawns, 1950–1992.

Thunderbolts, 1992–1994.

### Chronology of Significant Events

**20 Oct–15 Nov 1951:** During training operations in the Caribbean, the squadron operated aboard three different carriers. They departed from Norfolk aboard *Midway* (CVB 41) and then transferred to *Wright* (CVL 49) while the ships were off the coast of Puerto Rico. A couple of days later the squadron was transferred to *Cabot* (CVL 28) while operating at sea.

**Jan–Apr 1956:** The squadron operated aboard the Navy's first super carrier, *Forrestal* (CVA 59), during her shakedown cruise.

**24 Oct 1958:** The primary mission of VA-42 was changed to the training of fleet replacement pilots in the AD (A-1) Skyraider. The training involved all-weather flight training, low-level navigation flights, simulated special weapons training flights, conventional weapons training flights, and day and night carrier qualifications.

**19 Feb 1959:** VA-42 graduated its first AD Skyraider replacement pilot.

**9 Mar 1959:** With the acquisition of the T-28B aircraft, VA-42's instrument instructors used this plane to conduct all-weather flight training for the light attack community.

**10 Nov 1962:** VA-42 pilots flew three A-1H Skyraiders from Argentia, Newfoundland, to Rota, Spain, via Lajes, Azores. The squadron claims this was the first trans-Atlantic flight conducted by A-1H Skyraiders.

**1 Feb 1963:** VA-42 became the first fleet squadron to receive the A-6A Intruder. The squadron also initiated the Fleet Introduction Program for the all-weather A-6A. VA-42's new mission was the training of A-6A Bombardier/Navigators, as well as its pilots. It was also responsible for conducting the A-6A Fleet Replacement Aviation Maintenance Program which trained maintenance personnel.

**12 Jun 1963:** The Green Pawns received the first A-6A (bureau number 149939) with a complete weapon system, thereby permitting the initiation of weapon system indoctrination flight training program for VA-42's instructor pilots and bombardier/navigators.

**3 Sep 1963:** Formal flight training in the A-6A fleet replacement program began with the convening of Class 1-63. This training was for VA-75 pilots and bombardier/navigators.

**8 Sep 1963:** The squadron's last A-1H Skyraider (bureau number 135324) was transferred. This brought to a close the training of A-1 replacement pilots by VA-



The Green Pawn insignia was used by the squadron for almost 40 years.



In 1992, the squadron's insignia was officially changed from the Green Pawn to the mailed fist and lightning bolt previously used by Attack Squadron 176.

42. VA-42 still maintained one A-1E and two T-28Bs for use in propeller instrument training.

**14 Oct 1963:** The Green Pawns conducted the first fleet night arrested landings and catapult launchings with the A-6A aboard the *Forrestal* (CVA 59).

**12 Mar 1964:** The squadron's last T-28B was transferred, and the instrument training program for fleet A-1 pilots came to an end. Two days later, their last Skyraider, an A-1E, was transferred.

**13 Mar 1964:** VA-75 became the first fully trained fleet A-6A squadron ready for deployment following successful completion of VA-42's fleet introduction program on the A-6A.

**15 Dec 1964:** VMA-242 became the first Marine Corps squadron to complete transition training in the A-6A and qualify for fleet deployment with the Intruder.

**28 Jan 1968:** With the acquisition of the TC-4C aircraft, VA-42 was able to provide more training on airborne radar operation for A-6A bombardier/navigators. The new aircraft was equipped with a complete A-6A cockpit console and weapon system, multiple bombardier/navigator stations, plus ECM equipment, and other radar operational capabilities.

**Nov 1968:** VA-42's A-6A pilot training syllabus was modified to include lessons learned from the Intruder's employment in combat. The new tactics phase included air combat maneuvering and Sidewinder missile shoots, while conventional weapons training was made more realistic.

**12 Nov 1969:** With the acquisition of the updated Intruder, the A-6B, in June 1969, the squadron developed a new training syllabus for the A-6B Standard ARM aircraft and a detachment from VA-165 became the first to complete this course of instruction on 12 November 1969.

**21 Nov 1969:** The squadron assumed the duties of providing A-6 orientation training for Air Intelligence Officers reporting to fleet A-6 squadrons. Lieutenant (jg) Erickson became the first Air Intelligence Officer to complete the training on 21 November 1969.

**1 Oct 1971:** When COMMATWING ONE was established on 1 October, VA-42 was reassigned from COMFAIRNORFOLK to this command, and VA-42's Commanding Officer, CDR Andrassy, was also assigned as Commander of Medium Attack Wing One, making him dual-hatted.

**5 Jan 1973:** VA-42's Commanding Officer, CDR Zick, was relieved of his duties as COMMATWING ONE by CAPT Turk ending the dual-hatted role of the squadron's commanding officer.

**1980:** Lieutenant (jg) Beth Hubert was trained as an A-6 Intruder pilot by the Green Pawns and became the first woman naval aviator to qualify as an A-6 pilot.

**Jan 1982:** VA-42 implemented a training program for the Harpoon weapons system.

**Jun 1982:** A VA-42 pilot became the first female naval aviator to make an arrested landing in an A-6 during carrier qualifications on *Lexington* (AVT 16).



*Squadron F4U-4 Corsairs prepare to launch from Midway (CVA 41) during her cruise to the Med in 1953.*

### Home Port Assignments

<i>Location</i>	<i>Assignment Date</i>
NAAS Oceana	01 Sep 1950
NAS Jacksonville	19 Sep 1950
NAAS Cecil Field	09 Jun 1951
NAAS Oceana (later NAS*)	27 Aug 1951

\* NAAS Oceana redesignated NAS Oceana on 1 April 1952.

### Commanding Officers

	<i>Date Assumed Command</i>
LCDR Ross B. Spencer	01 Sep 1950
LCDR Millard C. Thrash	22 Aug 1951
LCDR Shelley B. Pittman	01 Jul 1953
LCDR Leroy P. Smith	08 Oct 1953
CDR L. W. Squires	09 Aug 1955
CDR Clifton R. Largess, Jr.	10 Jul 1957
CDR Robert (nmn) Linwick, Jr.	15 Aug 1958
CDR M. J. Stack	05 Aug 1959
CDR F. M. McLinn	10 Aug 1960
CDR Ted L. Farrell	22 Nov 1961
CDR J. S. Herman	28 Dec 1962
CDR W. S. Nelson	22 Nov 1963
CDR L. A. Snead	20 Aug 1965
LCDR J. C. Ellison	17 Jun 1966
CDR W. N. Small	18 Jul 1966
CDR A. H. Barie	Jun 1967
CDR Frank Cramblet	20 Jun 1968
CDR Robert J. Sample	18 Jul 1969
CDR Jerrold M. Zacharias	02 Jul 1970
CDR Michael F. Andrassy	09 Jul 1971
CDR Richard A. Zick	31 Aug 1972
CDR Thomas E. Shanahan	17 Aug 1973
CDR Samuel L. Sayers	10 Jan 1975
CDR William H. Greene, Jr.	12 Mar 1976
CDR Jackson E. Cartwright	24 Jun 1977



*A squadron Skyraider refuels an F9F-8P Cougar from VFP-62 in 1958.*

**Commanding Officers—Continued**

	<i>Date Assumed Command</i>
CDR John K. Peiguss	29 Sep 1978
CAPT William R. Galbraith	18 Jan 1980
CDR John A. Pieno	24 Apr 1981
CDR Herbert A. Browne, Jr.	02 Jul 1982
CDR John M. Luecke, Jr.	30 Sep 1983
CDR Allen H. White	10 Jan 1985
CDR Robin Y. Weber	30 Jul 1986
CDR Garth A. Van Sickle	17 Jul 1987
CDR Stephen H. Baker	26 Oct 1988
CDR John T. Meister	13 Dec 1989
CDR Daniel J. Franken	03 Jul 1991
CDR Bernard M. Satterwhite, Jr.	15 Dec 1992

**Aircraft Assignments**

<i>Type of Aircraft</i>	<i>Date Type First Received</i>
F4U-4	Sep 1950
AD-4	Sep 1953
AD-4L	Oct 1953
AD-6	Nov 1953
AD-4N	Dec 1953
T-28B	09 Mar 1959
A-6A	01 Feb 1963
TC-4C	28 Jan 1968
A-6B	Jun 1969
A-6C	1971
A-6E	02 Dec 1971
KA-6D	1976



*A flight of squadron AD (A-1) Skyraiders.*

### **Major Overseas Deployments**

<i>Date of Departure</i>	<i>Date of Return</i>	<i>Air Wing</i>	<i>Carrier</i>	<i>Type of Aircraft</i>	<i>Area of Operation</i>
06 Mar 1951	08 Jun 1951	AirDet	CVL 48	F4U-4	Med
01 Dec 1952	19 May 1953	CVG-6	CVA 41	F4U-4	Med
30 Nov 1954	18 Jun 1955	ATG-181	CVA 15	AD-6	Med
12 Oct 1956	22 May 1957	ATG-181	CVA 20	AD-6	WestPac
09 Jun 1958	08 Aug 1958	ATG-181	CVA 11	AD-6	NorLant



*A T-28B Trojan used by the squadron for instrument all-weather flight training.*

### **Air Wing Assignments**

<i>Air Wing</i>	<i>Tail Code</i>	<i>Assignment Date</i>
CVG-6	C	01 Sep 1950
ATG-181*	I	24 July 1956
CVG-8	AJ	14 Aug 1958
RCVG-4†	AD	24 Oct 1958
COMFAIRNORFOLK‡	AD	01 May 1970
COMMATWING ONE	AD	01 Oct 1971

\* VA-42 had operated as part of ATG-181 prior to July 1956. However, ATG-181 was not assigned a tail code letter until 24 July 1956. Prior to July 1956 VA-42 still carried the tail code for CVG-6 even though it deployed as part of ATG-181.

† RCVG-4 redesignated RCVW-4 on 20 December 1963.

‡ On 1 June 1970, RCVW-4 was disestablished. The AD tail code that had been allocated to RCVW-4 and its assigned squadrons continued to be used by the squadrons that had been in RCVW-4. VA-42 continued to use the AD tail code for its aircraft.



*A squadron TC-4C Academe used to train Naval Flight Officers as bombardier navigators.*

**Unit Awards Received**

<i>Unit Award</i>	<i>Inclusive Dates Covering Unit Award</i>	
MUC	Jan 1979	Dec 1981
	01 Oct 1986	30 Sep 1988



*A flight of the squadron's A-6E Intruders on a training mission in 1974.*

## VA-44

### Lineage

Established as Bombing Squadron SEVENTY FIVE (VB-75) on 1 June 1945.

Redesignated Attack Squadron THREE B (VA-3B) on 15 November 1946.

Redesignated Attack Squadron FORTY FOUR (VA-44) on 1 September 1948.

Disestablished on 8 June 1950. The first squadron to be assigned the VA-44 designation.

### Squadron Insignia and Nickname

The squadron's insignia was approved by CNO on 23 August 1945. VB-75's insignia colors were as follows:



*This insignia was approved for use by the squadron when it was designated VB-75.*

the bee's gloves were white; its lower body had bands of green and yellow with a deep scarlet tip; dark gray telescope with white highlights and a white lens, forest green bomb with yellow fins and the rocket had yellow fins and nose while the body was forest green; the banner was royal blue with yellow lettering.

When redesignated as an attack squadron, a new insignia was approved by CNO on 8 August 1947. The indian head and bomb insignia represented the bombing and scouting mission of the carrier based squadron. Its colors were: red background with a blue border outlined in black; black bomb with the center portion white; the indian head silhouette was black with the center portion white; the for-



*A new insignia was approved for the squadron following its redesignation to VA-3B. Note the use of the squadron designation in the insignia design. During World War II, squadron numbers or designations were not permitted in the design.*

ward part of the carrier was black while the fantail was white; blue feather tipped with red; and the scroll was white, outlined in black with black letters.

When the squadron was redesignated VA-44 it submitted a request to change its insignia to a scarlet chess knight centered on a white shield. There is no record of official approval by CNO for this insignia.

Nickname: unknown

### Chronology of Significant Events

**4 Jun 1945:** The squadron began its first flight operations.

**Jan-Feb 1946:** VB-75 deployed aboard *Franklin D. Roosevelt* (CVB 42) for her shakedown cruise to the Caribbean and Brazil. While visiting Rio de Janeiro the squadron, air group, and carrier represented the U.S. at the inauguration of Brazilian president, Eurico G. Dutra.

### Home Port Assignments

Location	Assignment Date
NAAS Chincoteague	1 Jun 1945
NAS Norfolk	Mar 1946
NAS Jacksonville	12 Feb 1949

### Commanding Officers

	Date Assumed Command
LT Ben K. Harrison (acting)	01 Jun 1945
LCDR John W. McManus	10 Jun 1945
LCDR Elmer Maul	20 Dec 1946
LCDR Oscar I. Chenoweth, Jr.	03 Dec 1947
LT K. F. Rowell (acting)	30 Jan 1949
LCDR Robert N. Miller	28 Feb 1949



*A formation of squadron AD-1 Skyraiders in flight, circa 1948 (Courtesy Robert Lawson Collection).*



**Aircraft Assignment**

Type of Aircraft	Date Type First Received
SBF-4E	Jun 1945
SB2C-4E	Aug 1945
SB2C-5	Mar 1946
AD-1	20 Mar 1947

**Aircraft Assignment—Continued**

Type of Aircraft	Date Type First Received
AD-1Q	May 1948
AM-1	25 Feb 1949
AD-1	12 Oct 1949

**Major Overseas Deployments**

Date of Departure	Date of Return	Air Wing	Carrier	Type of Aircraft	Area of Operation
08 Jan 1946	19 Mar 1946	CVBG-75	CVB 42	SB2C-4E	Carib/SoLant
08 Aug 1946	04 Oct 1946	CVBG-75	CVB 42	SB2C-5	Med
13 Sep 1948	23 Jan 1949	CVG-4	CVB 42	AD-1	Med
06 Jan 1950	23 May 1950	CVG-4	CVB 41	AD-1	Med

**Air Wing Assignments**

Air Wing	Tail Code	Assignment Date
CVBG-75/CVBG-3/CVG-4*	F	01 Jun 1945

\* CVBG-75 was established on 1 June 1945, redesignated CVBG-3 on 15 November 1946; redesignated CVG-4 on 1 September 1948 and disestablished on 8 June 1950.



*A squadron AM-1 Mauler launches from Midway (CVB 41), circa 1949 (Courtesy Robert Lawson Collection).*

## SECOND VA-44

### Lineage

Established as Fighter Squadron FORTY FOUR (VF-44) on 1 September 1950.

Redesignated Attack Squadron FORTY FOUR (VA-44) on 1 January 1956.

Disestablished on 1 May 1970. The second squadron to be assigned the VA-44 designation.



*The squadron insignia used by VF-44 and VA-44. Note the unique use of the 4 of clubs and 4 of hearts to identify the squadron's designation number.*

### Squadron Insignia and Nickname

The squadron's insignia was approved by CNO on 11 December 1952. The insignia consisted of a blue shield; a yellow banner across the shield with the word "Hornets" in red; two white playing cards, one had four black clubs and the other four red hearts; the caricature of the hornet was yellow and black with a red eye and white details. When the squadron was redesignated VA-44, it retained the same insignia.

Nickname: Hornets, 1950–1970.

### Chronology of Significant Events

**13 Jun 1953:** The squadron conducted its first combat operations, striking targets in Korea.

**Sep–Oct 1957:** During the squadron's deployment aboard *Wasp* (CVS 18), its mission was temporarily changed from attack to a fighter role in order to provide air protection for the VS squadrons operating from the carrier.

**1 Jun 1958:** The squadron's mission changed from a light attack squadron to a fleet replacement training squadron. The new mission involved flight training for pilots and maintenance training for enlisted personnel. Under this concept, pilots and enlisted personnel ordered to East Coast fleet A4D squadrons completed the course of instruction provided by VA-44 before reporting to their assigned fleet squadrons.

**6 Jun 1958:** Fleet All Weather Training Unit Detachment ALFA, an instrument training detachment, was disestablished and its personnel and aircraft were transferred to VA-44.

**8 Aug 1958:** The squadron graduated its first replacement pilot under the new training program for attack pilots.

**Jan 1959:** The squadron's first AD Skyraiders arrived

and preparations began for the additional mission of replacement training for this aircraft, plus the A4D Skyhawk.

**15 Nov 1961:** The squadron graduated the 1,000th enlisted maintenance trainee on the A4D Skyhawk.

**15 Feb 1963:** The propeller training section of the squadron was removed from VA-44 and established as a separate squadron and designated VA-45. VA-44 continued in its training mission concentrating on A-4 Skyhawk training. It became a strictly jet squadron flying A-4Bs, A-4Cs and TF-9Js.



*A squadron F4U-4 Corsair on the deck of Boxer (CVA-21) during a combat tour to Korea, circa 1953 (Courtesy Robert Lawson Collection).*

### Home Port Assignments

<i>Location</i>	<i>Assignment Date</i>
NAS Jacksonville	01 Sep 1950
NAAS Cecil Field	19 Sep 1950
NAS Jacksonville	13 Oct 1952
NAS Cecil Field	18 Feb 1963

### Commanding Officers

	<i>Date Assumed Command</i>
LCDR J. B. Bain (acting)	01 Sep 1950
LCDR P. E. Greenlee, Jr.	11 Sep 1950
LCDR Reid W. Stone	09 Dec 1951
LCDR W. D. Houser	10 Nov 1952
CDR V. P. O'Neil	Nov 1953
CDR C. A. Crow, Jr.	Oct 1954
LCDR Theron J. Taylor	27 Jan 1956
CDR T. R. Sedell	Jun 1957
CDR Clifford A. McDougal	30 Jun 1958
CDR Damon W. Cooper	14 Jul 1959
CDR A. L. Detweiler	22 Jul 1960
CDR W. B. Barrow, Jr.	21 Jul 1961
CDR M. C. Griffin	17 Apr 1962
CDR S. W. Callaway, Jr.	06 Mar 1963
CDR Harold K. Matthes	May 1964
CDR Max E. Malan	Jul 1965

**Commanding Officers—Continued**

	<i>Date Assumed Command</i>
CDR James W. Roberts	22 Sep 1966
CDR Joe D. Adkins	Oct 1967
CDR J. H. Wynn III	Feb 1969
CDR Robert E. Holt	Jan 1970



A squadron F2H-2 Banshee is prepared for launch from *Intrepid* (CVA 11) during her Med deployment in 1955.

**Aircraft Assignment**

<i>Type of Aircraft</i>	<i>Date Type First Received</i>
F4U-5	Sep 1950
F4U-4	01 Dec 1951
F2H-2	Dec 1953
F9F-8	Apr 1956
F9F-8T/TF-9J*	23 Jan 1958
A4D-1	04 Feb 1958
TV-2	Jun 1958
T-28B	Jun 1958
A4D-2/A-4B*	Sep 1958
AD-5 and 6/A-1E and H*	Jan 1959
A4D-2N/A-4C*	09 Feb 1960
A-4E	Oct 1964
TA-4F	03 Aug 1966
A-4F	Nov 1969
A-4L	Dec 1969

\* The F9F-8T, A4D-2, AD-5 and 6, and A4D-2N designations were changed in 1962 to TF-9J, A-4B, A-1E and H, and A-4C, respectively.

**Major Overseas Deployments**

<i>Date of Departure</i>	<i>Date of Return</i>	<i>Air Wing</i>	<i>Carrier</i>	<i>Type of Aircraft</i>	<i>Area of Operation</i>
20 Mar 1951	06 Oct 1951	CVG-1	CVB 43	F4U-5	Med
19 Apr 1952	12 Oct 1952	CVG-4	CVB 43	F4U-4	Med
26 Apr 1953	04 Dec 1953	CVG-4/ATG-1*	CVA 39/CVA 21*	F4U-4	Med/IO/ WestPac/Korea
28 May 1955	22 Nov 1955	CVG-4	CVA 11	F2H-2	Med
30 Aug 1957	22 Oct 1957	†	CVS 18	F9F-8	NorLant

\* VF-44 deployed to Korea as part of CVG-4 embarked in *Lake Champlain* (CVA 39) and conducted its first line period from *Lake Champlain*. On 30 June 1953, the squadron was transferred to ATG-1 aboard *Boxer* (CVA 21). The squadron remained aboard *Boxer* until 9 October 1953 when it transferred back to CVG-4 and *Lake Champlain*.

† Unable to locate records indicating a carrier air group aboard during this deployment on *Wasp* (CVS 18). Antisubmarine carrier air groups were not established until 1960.



A squadron F9F-8T (TF-9J) Cougar in flight, circa 1964 (Courtesy Robert Lawson Collection).

**Air Wing Assignments**

<i>Air Wing</i>	<i>Tail Code</i>	<i>Assignment Date</i>
CVG-4	F	01 Sep 1950
CVG-1	T	19 Mar 1951
CVG-4	F	08 Oct 1951
ATG-1		30 Jun 1953
CVG-4	F	09 Oct 1953
COMFAIRJACKSONVILLE		1957
ATG-202	AQ	15 Feb 1958
CVG-4/RCVG-4/RCVW-4*	AD	15 Mar 1958

\* CVG-4 was redesignated RCVG-4 in April 1958. On 20 December 1963, RCVG-4 was redesignated RCVW-4.

**Unit Awards Received**

<i>Unit Award</i>	<i>Inclusive Dates Covering Unit Award</i>	
KPUC	09 Jun 1953	27 Jul 1953
KSM	09 Jun 1953	27 Jul 1953
UNSM	09 Jun 1953	27 Jul 1953



*Squadron A-4 Skyhawks in flight with the day-glow paint scheme.*

## VA-45

### Lineage

Established as Torpedo Squadron SEVENTY FIVE (VT-75) on 1 June 1945.

Redesignated Attack Squadron FOUR B (VA-4B) on 15 November 1946.

Redesignated Attack Squadron FORTY FIVE (VA-45) on 1 September 1948.

Disestablished on 8 June 1950. The first squadron to be assigned the VA-45 designation.

### Squadron Insignia and Nickname

VT-75's insignia was approved by CNO on 10 August 1945. Colors for the Fish-Hawk insignia were:



The insignia approved for use by VT-75.

light blue background outlined in black by two concentric circles; white clouds with black outlines; turquoise waves; riding astride a torpedo was an animated hawk clothed in a green flying suit with white parachute straps and sitting on a gray parachute pack; brown shoes; yellow hands and beak; red eye; black hair and tongue; gray face; pink earphones with a black center and a white band outlined in black; gray rocket and gun with red tips; brown torpedo with a yellow nose, white teeth, red eye and outlined in black; and the words "The Fish-Hawks" were black.



The squadron's second insignia was part of its carrier air group's approach for insignia used by its assigned squadrons. In the air group, the king chess piece was for the air group, the knight chess piece was for the attack squadron and the pawn was for the fighter squadron.

There is no record of the insignia used by the squadron after it was redesignated VA-4B. When the squadron was redesignated VA-45, it adopted a new insignia which was approved by CNO on 15 April 1949. This insignia was a black chess knight on a white shield outlined in black.

Nickname: Fish-Hawks, 1945-unknown.

### Chronology of Significant Events

Jan-Feb 1946: VT-75 deployed aboard *Franklin D. Roosevelt* (CVB 42) for her shakedown cruise to the Caribbean and Brazil. While visiting Rio de Janeiro the squadron, air group, and carrier represented the U.S. at the inauguration of Brazilian president, Eurico G. Dutra.

### Home Port Assignments

Location	Assignment Date
NAAS Chincoteague	01 Jun 1945
NAS Norfolk	20 Mar 1946
NAS Jacksonville	14 Feb 1949

### Commanding Officers

	Date Assumed Command
LT Richard W. Bond (acting)	01 Jun 1945
LT Paul J. Davis, Jr.	11 Jun 1945
LCDR James E. Mahan	28 Jun 1945
LCDR Garald R. Stablein	31 Oct 1946
LCDR Chester L. Dillard (acting)	19 Feb 1947
LCDR Lucien G. Powell, Jr.	26 May 1947
LCDR Leroy V. Swanson	15 Jun 1948
LCDR Frederick C. Kidd	27 May 1950



A squadron SB2C-4E prepares to launch from *Franklin D. Roosevelt* (CVB-42), January 1946 (Courtesy Robert Lawson Collection).

### Aircraft Assignment

Type of Aircraft	Date Type First Received
SBF-4E	Jun 1945
SBW-4E	Jun 1945
SB2C-4E	Sep 1945
SB2C-5	Mar 1946
AD-1	27 Mar 1947
AM-1	Feb 1949
AD-1	20 Oct 1949

### Major Overseas Deployments

<i>Date of Departure</i>	<i>Date of Return</i>	<i>Air Wing</i>	<i>Type of Carrier</i>	<i>Area of Aircraft</i>	<i>Operation</i>
08 Jan 1946	19 Mar 1946	CVBG-75	CVB 42	SB2C-4E	Carib/SoLant
08 Aug 1946	04 Oct 1946	CVBG-75	CVB 42	SB2C-5	Med
13 Sep 1948	23 Jan 1949	CVG-4	CVB 42	AD-1	Med
06 Jan 1950	23 May 1950	CVG-4	CVB 41	AD-1	Med



A squadron AM-1 Mauler in flight; note the squadron's insignia on the cowling, circa 1949 (Courtesy Wallace Russel Collection).

### Air Wing Assignments

<i>Air Wing</i>	<i>Tail Code</i>	<i>Assignment Date</i>
CVBG-75/CVBG-3/CVG-4*	F	01 Jun 1945

\* CVBG-75 was established on 1 June 1945; redesignated CVBG-3 on 15 November 1946; redesignated CVG-4 on 1 September 1948 and disestablished on 8 June 1950.



A squadron AD Skyraider taxis on flight deck of Intrepid (CVA-11), circa 1955 (Courtesy Robert Lawson Collection).

## SECOND VA-45

### Lineage

Established as Attack Squadron FORTY FIVE (VA-45) on 1 September 1950.

Disestablished on 1 March 1958. The second squadron to be assigned the VA-45 designation.

### Squadron Insignia and Nickname

The squadron's insignia was approved by CNO on 10 April 1951. A blackbird in a cocky stance became the focal point of the insignia's design. Colors for the insignia were: an oval design with a light blue background; black crow and cigar; the bird's legs, feet and gloves were yellow; red tongue; the cigar ash and shaded area of the gloves were red; white star and spats; green derby; and the lower portion of the insignia had a dark green background with the numbers 4 and 20 in yellow. The numbers 4 and 20 were taken from the



The well-known 4 and 20 black birds insignia was first used by this squadron.

nursery rhyme, "Four and Twenty Blackbirds" and represent the original 24 pilots assigned to the squadron. Nickname: Blackbirds, 1950–1958.

### Chronology of Significant Events

**13 Jun 1953:** The squadron flew its first combat operation while deployed to Korea aboard *Lake Champlain* (CVA 39).

### Home Port Assignments

Location	Assignment Date
NAS Jacksonville	01 Sep 1950
NAAS Cecil Field	18 Sep 1950
NAS Jacksonville	12 Oct 1952

### Commanding Officers

	Date Assumed Command
LCDR G. O. Wood	01 Sep 1950
LCDR Richard H. Mills	11 Apr 1952
LCDR William F. Krantz	Oct 1953
CDR Daniel W. Wildfong	Nov 1954
CDR Glendon Goodwin	Dec 1955

### Aircraft Assignment

Type of Aircraft	Date Type First Received
AD-2	Sep 1950
AD-4	14 Feb 1952
AD-6	Jun 1954



Squadron personnel load 5-inch high-velocity aircraft rockets on one of its AD-6 Skyraiders prior to launch.

**Major Overseas Deployments**

<i>Date of Departure</i>	<i>Date of Return</i>	<i>Air Wing</i>	<i>Type of Carrier</i>	<i>Area of Aircraft</i>	<i>Operation</i>
15 May 1951	04 Oct 1951	CVG-4	CV 34	AD-2	Med
19 Apr 1952	12 Oct 1952	CVG-4	CVB 43	AD-4	Med
26 Apr 1953	04 Dec 1953	CVG-4	CVA 39	AD-4	WestPac/Korea
28 May 1955	22 Nov 1955	CVG-4	CVA 11	AD-6	Med
01 Jul 1957	24 Feb 1958	CVG-4	CVA 15	AD-6	Med

**Air Wing Assignments**

<i>Air Wing</i>	<i>Tail Code</i>	<i>Assignment Date</i>
CVG-4	F	01 Sep 1950

**Unit Awards Received**

<i>Unit Award</i>	<i>Inclusive Dates Covering Unit Award</i>	
KPUC	09 Jun 1953	27 Jul 1953
KSM	09 Jun 1953	27 Jul 1953
UNSM	09 Jun 1953	27 Jul 1953



*A squadron AD-6 Skyraider launches from the deck of Intrepid (CVA 11) in 1955.*



## VA-46

### Lineage

Established as Attack Squadron FORTY SIX (VA-46) on 24 May 1955.

Disestablished on 30 June 1991. The first squadron to be assigned the VA-46 designation.

### Squadron Insignia and Nickname

VA-46's insignia was approved by CNO on 25 November 1960. The circular insignia had a blue field outlined by two concentric black lines; the McDougal clan tartan, drawn from the heritage of the squadron's first commanding officer, had dark blue and white lines on a red background, interspaced with green squares; the crest was white, outlined in black with the Latin words *Vincere Vel Mori*, meaning to conquer or to die; a white stylized aircraft outlined in black; and the banner was white with the designation VA 46 in black.



VA-46's insignia with the distinctive McDougal clan tartan.

Nickname: Clansmen, 1960–1991.

### Chronology of Significant Events

**14 Jul 1956:** VA-46 departed the U.S. aboard *Randolph* (CVA 15) for deployment to the Mediterranean, equipped with Sidewinder missiles. This was the first overseas deployment of the Sidewinder.

**Oct–Nov 1956:** VA-46, along with other units of ATG-202, provided air support for the evacuation of foreign nationals from Alexandria, Egypt, during the Suez War.

**Aug 1965:** VA-46 and other units of the air wing aboard *Shangri-La* (CVA 38) operated off the coast of Cyprus in response to a crisis in that country between Greek and Turkish Cypriots.

**25 Jul 1967:** The squadron engaged in its first combat operations.

**29 Jul 1967:** While aircraft were being prepared for the second launch of the day against targets in Vietnam, a fire broke out on the flight deck of

*Forrestal* (CVA 59). Flames engulfed the fantail and spread below decks touching off bombs and ammunition. Heroic efforts by VA-46 personnel, along with other members of CVW-17 and ship's company, brought the fires under control. Damage to the carrier and aircraft was severe and the casualty count included 132 dead, two missing and presumed dead and 62 injured.

**4 May–15 Nov 1968:** VA-46 transitioned to the A-7 Corsair II.

**17 Sep 1970:** While enroute to the Caribbean for training exercises, *John F. Kennedy* (CVA 67) with VA-46 and other units of CVW-1 embarked, received emergency orders to deploy immediately to the Mediterranean due to the Jordanian Crisis and the hijacking of four airliners by Arab terrorists. They remained on station off the coast of Israel until November.

**Oct 1973:** Due to the outbreak of war between Israel and Egypt and Syria, *Kennedy* and her air wing, while operating in the North Atlantic after just completing a Mediterranean deployment, were ordered back to the Mediterranean. During the latter part of October through mid November, VA-46 conducted flight operations while the carrier was on station south of Crete.

**22 Nov 1975:** During night operations *Kennedy* collided with *Belknap* (CG 26) causing major damage to the cruiser. Eight VA-46 personnel received awards for their heroism and devotion to duty as a result of their actions following the collision.

**17–19 Sep 1985:** VA-46, along with other units of CVW-1, were the first to conduct flight operations from a carrier operating inside a fjord. *America* (CV 66) operated in Vestfjord, Norway, during this evolution.

**14 Apr 1986:** Because of terrorist activities linked to Lybia, American forces struck targets in that country. During that action, VA-46 provided air-to-surface Shrike and Harm missile strikes against Libyan radar missile sites.

**Sep–Oct 1990 and Dec 1990–Jan 1991:** The squadron participated in Operation Desert Shield, the build up of American and Allied forces to counter a threatened invasion of Saudi Arabia by Iraq and as part of an economic blockade of Iraq to force its withdrawal from Kuwait.

**17 Jan 1991:** Operation Desert Storm, combat operations to remove Iraqi forces from Kuwait, was launched. The squadron's A-7E Corsair IIs participated in the first combat strike against Iraqi targets in Baghdad.



A squadron F9F-8 Cougar preparing for a launch from Randolph (CVA 15).

### Home Port Assignments

<i>Location</i>	<i>Assignment Date</i>
NAS Cecil Field	24 May 1955

### Commanding Officers

	<i>Date Assumed Command</i>
LT Charles L. Marshall (acting)	24 May 1955
CDR Clifford A. McDougal	22 Jun 1955
CDR A. R. Hawkins	10 May 1957
CDR Kent L. Lee	15 Aug 1958

### Commanding Officers—Continued

	<i>Date Assumed Command</i>
CDR Alfred J. Hall, Jr.	21 Sep 1959
CDR Hugh J. Tate	07 Sep 1960
CDR S. W. Callaway, Jr.	13 Dec 1961
CDR W. H. Sells	10 Dec 1962
CDR R. P. McKenzie	04 Dec 1963
CDR M. P. Mead	28 Oct 1964
CDR R. L. Lawler, Jr.	12 Nov 1965
CDR Fred S. Dunning, Jr.	17 Nov 1966
CDR Jack F. O'Hara	Nov 1967
CDR Alan G. Murdoch	04 Sep 1968
CDR Fred J. Withers	30 Jan 1970
CDR Marvin D. Reynolds	10 Mar 1971
CDR Dale Lewey	03 Mar 1972
CDR Jeremy D. Taylor	23 Mar 1973
CDR Ronald R. Boyle	13 Jun 1974
CDR Edward F. Bronson	Aug 1975
CDR David A. Page	23 Nov 1976
CDR James T. Matheny	16 Feb 1978
CDR Phillip J. Rooney	24 May 1979
CDR Morris M. Demple, Jr.	08 Jul 1980
CDR Thomas R. Mitchell III	01 Oct 1981
CDR John W. Peterson	23 Dec 1982
CDR Dean M. Hendrickson, Jr.	13 Jun 1984
CDR Robert C. Kolsterman	21 Jan 1986
CDR Tommy H. Van Brunt	May 1987
CDR Edward J. Fahy, Jr.	04 Nov 1988
CDR Mark Fitzgerald	22 May 1990



A squadron A-4C Skyhawk flies over Shangri-La (CVA 38) during their deployment to the Med in 1962.

**Aircraft Assignment**

<i>Type of Aircraft</i>	<i>Date Type First Received</i>
F9F-5	Jun 1955
F9F-8	Aug 1955
A4D-2	Mar 1958
A4D-2N/A-4C*	29 Aug 1960
A-4E	Jan 1967

**Aircraft Assignment—Continued**

<i>Type of Aircraft</i>	<i>Date Type First Received</i>
A-4B	Sep 1967
A-7B	15 Nov 1968
A-7E	Aug 1977

\* The A4D-2N designation was changed to A-4C in 1962.

**Major Overseas Deployments**

<i>Date of Departure</i>	<i>Date of Return</i>	<i>Air Wing</i>	<i>Carrier</i>	<i>Type of Aircraft</i>	<i>Area of Operation</i>
14 Jul 1956	19 Feb 1957	ATG-202	CVA 15	F9F-8	Med
13 Feb 1959	30 Aug 1959	CVG-6	CVA 11	A4D-2	Med
28 Jan 1960	24 Aug 1960	CVG-1	CVA 42	A4D-2	Med
02 Feb 1961	15 May 1961	CVG-10	CVA 38	A4D-2N	Med
07 Feb 1962	28 Aug 1962	CVG-10	CVA 38	A4D-2N	Med
01 Oct 1963	23 May 1964	CVG-10	CVA 38	A-4C	Med
10 Feb 1965	20 Sep 1965	CVG-10	CVA 38	A-4C	Med
11 Mar 1966	26 Oct 1966	CVG-3	CVA 60	A-4C	Med
06 Jun 1967	15 Sep 1967	CVW-17	CVA 59	A-4E	WestPac/Vietnam
09 Jul 1969	22 Jan 1970	CVW-3	CVA 60	A-7B	Med
14 Sep 1970	01 Mar 1971	CVW-1	CVA 67	A-7B	Med/NorLant
01 Dec 1971	06 Oct 1972	CVW-1	CVA 67	A-7B	Med/NorLant
16 Apr 1973	01 Dec 1973	CVW-1	CV 67	A-7B	Med/NorLant
28 Jun 1975	27 Jan 1976	CVW-1	CV 67	A-7B	Med
02 Sep 1976	09 Nov 1976	CVW-1	CV 67	A-7B	NorLant
15 Jan 1977	01 Aug 1977	CVW-1	CV 67	A-7B	Med
29 Jun 1978	08 Feb 1979	CVW-1	CV 67	A-7E	Med
04 Aug 1980	28 Mar 1981	CVW-1	CV 67	A-7E	Med
23 Aug 1982	30 Oct 1982	CVW-1	CV 66	A-7E	NorLant/Med/Carib
08 Dec 1982	02 Jun 1983	CVW-1	CV 66	A-7E	Med/IO
24 Apr 1984	14 Nov 1984	CVW-1	CV 66	A-7E	Carib/Med/IO
24 Aug 1985	09 Oct 1985	CVW-1	CV 66	A-7E	NorLant
10 Mar 1986	10 Sep 1986	CVW-1	CV 66	A-7E	Med
29 Feb 1988	29 Aug 1988	CVW-7	CVN 69	A-7E	Med
15 Aug 1990	28 Mar 1991	CVW-3	CV 67	A-7E	Med/Red Sea

**Air Wing Assignments**

<i>Air Wing</i>	<i>Tail Code</i>	<i>Assignment Date</i>
CVG-4	F	24 May 1955
ATG-202	X/AQ*	Jul 1955
CVG-1	AB	15 Feb 1958
CVG-6	AF	13 Jan 1959
CVG-1	AB	30 Aug 1959
CVG-10/CVW-10†	AK	05 Dec 1960
CVW-3	AC	01 Jan 1966
CVW-17	AA	01 Jan 1967
CVW-3	AC	01 Jan 1968
CVW-1	AB	12 Feb 1970

**Air Wing Assignments—Continued**

<i>Air Wing</i>	<i>Tail Code</i>	<i>Assignment Date</i>
CVW-7	AG	01 Oct 1986
COMLATWING 1‡		Sep 1988
CVW-3	AC	01 Mar 1989

\* ATG-202's tail code was changed from X to AQ in the latter part of 1957. The effective date was most likely the beginning of FY 58 (1 July 1957).

† Carrier Air Groups were redesignated Carrier Air Wings on 20 December 1963, hence, CVG-10 became CVW-10.

‡ The squadron was detached from CVW-7 and came under the operational and administrative control of Commander Light Attack Wing 1.

**Unit Awards Received**

<i>Unit Award</i>	<i>Inclusive Dates</i>	<i>Covering Unit Award</i>
NAVE	01 Oct 1978	30 Sep 1979
	01 Oct 1980	31 Dec 1981
	01 Jan 1986	31 Dec 1986
	01 Jan 1988	31 Dec 1988
MUC	29 Sep 1970	31 Oct 1970
	01 Dec 1977	01 Mar 1979
	03 Jun 1983	20 Dec 1984
NEM	29 Aug 1985	20 Sep 1985
	01 Jan 1983	20 Jan 1983
	06 May 1983	08 May 1983

**Unit Awards Received—Continued**

<i>Unit Award</i>	<i>Inclusive Dates</i>	<i>Covering Unit Award</i>
NUC	21 Mar 1986	27 Jun 1986
	17 Mar 1986	23 Mar 1986
SLOC	17 Jan 1991	28 Feb 1991
	04 Aug 1980	28 Mar 1981
VNSM	23 Aug 1982	02 Jun 1983
	15 Jul 1967	17 Jul 1967
	23 Jul 1967	31 Jul 1967
KLM	12 Aug 1967	13 Aug 1967
	17 Jan 1991	28 Feb 1991
	14 Sep 1990	12 Mar 1991



*A flight of squadron A-7E Corsair IIs in 1979.*

## VA-52

### Lineage

Established as Fighter Squadron EIGHT HUNDRED EIGHTY FOUR (VF-884), a reserve squadron, on 1 November 1949.

Called to active duty on 20 July 1950.

Redesignated Fighter Squadron ONE HUNDRED FORTY FOUR (VF-144) on 4 February 1953.

Redesignated Attack Squadron FIFTY TWO (VA-52) on 23 February 1959. The first to be assigned the VA-52 designation.

### Squadron Insignia and Nickname

VF-884 was assigned to NAS Olathe, Kansas, prior to being called to active duty. The insignia, approved by CNO on 29 January 1951, portrayed its association with the state of Kansas.



*The design of the squadron's first insignia identifies their reserve home and reflects their feelings about being activated for the Korean Conflict.*

The circular designed insignia centered around a determined looking Jayhawk with a club in its hand. Inside the insignia were the words "Bitter Birds," reflecting the squadron's feelings about the Korean Conflict and its call to active duty. Colors for the insignia were: blue Jayhawk with red head and yellow beak,

gloves and shoes; black club; and a white background outlined in red.

When VF-884 was redesignated VF-144 on 4 February 1953 the old insignia apparently fell out of use and a new insignia was not approved until 23 May 1956. The new design depicted a stylized bird diving in the sky surrounded by a cone-shaped barrier.



*This stylized insignia was approved for squadron use following its redesignation as VF-144.*



*The knight and turtle insignia has been in use by the squadron for over three decades.*

Colors were: a blue background outlined in black; six white stylized stars, three above and three below the bird; a white outer cone with a yellow inner part; and a black bird.

In 1959 VF-144 was redesignated VA-52 and a squadron insignia was approved by CNO on 5 January 1960. This design depicts a stylized knight riding a sea turtle and armed with a mace. The knight and turtle are superimposed on a target. With the assignment of an attack mission the squadron's new insignia was designed to portray the pilot in the role of the knight, the legendary protector of honor. His means of transportation was a sea turtle, a capable and speedy performer in his element, the sea. Using his mace, a feared weapon from an earlier time, he exemplified the squadron's powerful striking capability. Colors for the insignia were: the outer part of the circular insignia was outlined in black; the next concentric circle was a light blue, followed by alternating colors of red and white to form the target; a white and black knight and turtle, with the boots and gloves of the knight a solid black; the spikes of the mace were solid black; the turtle was shaded black; the eye of the turtle was red; and a white scroll with black lettering.

Nickname: Bitter Birds, 1951-circa 1953.

Knightriders, circa 1960-present.

### Chronology of Significant Events

**20 Jul 1950:** VF-884 called to active duty as a result of the Korean conflict.

**28 Jul 1950:** Squadron reported for active duty at NAS San Diego.

**Mar 1951:** In the later part of March, VF-884 aircraft conducted their first combat operations, flying close air support missions on Korea's eastern coast.

**24 May 1951:** VF-884's first Commanding Officer, Lieutenant Commander G. F. Carmichael died after parachuting from his F4U which had been hit by enemy ground fire.

**4 Oct 1952:** Lieutenant E. F. Johnson was attacked and shot down by enemy MIG aircraft. This was the first VF-884 and CVG-101 aircraft shot down by enemy aircraft.

**8 Nov 1952:** Lieutenant Commander Bowen, VF-884's third Commanding Officer, was listed as missing in action when his aircraft crashed near Pyongyang, North Korea.

**4 Feb 1953:** VF-884 was redesignated VF-144 during its second combat tour in Korea. In this change, the reserve squadron number was replaced by an active squadron number.

**21 Feb 1953:** VF-144 completed the last line period of its second combat tour in Korea. Its primary missions had been close air support of ground troops, interdiction of enemy main supply routes, and the destruction of military supplies, vehicles and troops.

**18 Aug 1958:** The squadron returned to NAS

Miramar following *Ranger's* (CVA 61) first major deployment. The cruise took the squadron from Virginia to California, via Cape Horn, transferring *Ranger* from the Atlantic to the Pacific Fleet.

**23 Feb 1959:** The squadron's mission was changed to attack and it was redesignated VA-52.

**13 Jul-1 Aug 1964:** VA-52 aircraft participated in Yankee Team operations in South Vietnam and Laos, involving aerial reconnaissance to detect Communist military presence and operations. Other missions included weather reconnaissance and SAR.

**2-4 Aug 1964:** During a Desoto Patrol mission (intelligence collection missions begun in 1962), *Maddox* (DD 731) was attacked by three motor torpedo boats on 2 August off the coast of North Vietnam. Following this incident the squadron flew 44 sorties in support of the destroyers on the Desoto Patrol.

**4 Aug 1964:** During the night, two destroyers on Desoto Patrol, *Turner Joy* (DD 951) and *Maddox* (DD 731), believing themselves under attack by North Vietnamese motor torpedo boats, called for air support. Several A-1H Skyraiders from the squadron, along with several F-8s, were launched from *Ticonderoga* (CVA 14). Commander George H. Edmondson and Lieutenant Jere A. Barton reported gun flashes and bursts of light at their altitude which they felt came from enemy anti-aircraft fire.

**5 Aug 1964:** Four Skyraiders from VA-52, piloted by Commander L. T. McAdams, Lieutenant Commander L. E. Brumbach and Lieutenant (jg)s R. E. Moore and P. A. Carter, participated in "Pierce Arrow," retaliatory strikes against the North Vietnamese. Along with other aircraft from CVG-5, they struck the Vinh oil storage facilities and destroyed about ninety percent of the complex. The four aircraft returned with no battle damage.

**6-29 Oct 1964:** The squadron conducted rescue combat air patrols missions in support of "Yankee Team" operations.

**7 Feb 1966:** Lieutenant (jg) Harvey M. Browne was awarded the Silver Star for conspicuous gallantry and intrepidity during rescue missions in the Republic of Vietnam.

**13 Apr 1966:** Commander John C. Mape was killed in action, becoming the third VA-52 commanding officer to be lost in combat action.

**21 Apr 1966:** The squadron completed its second combat tour of duty in Vietnam, having participated in Rolling Thunder operations designed to interdict the enemy's lines of communication into Laos and South Vietnam.

**9 Mar 1967:** Commander John F. Wanamaker received the Silver Star for conspicuous gallantry and intrepidity during operations against North Vietnam.

**27 Apr 1967:** This was the last day of line operations for VA-52 and the completion of her third combat tour to Vietnam. During this deployment squadron operations included rescue combat air patrol missions, coastal reconnaissance, Steel Tiger missions and Sea Dragon operations. Steel Tiger involved concentrated strikes in southern Laos. Sea Dragon operations involved spotting for naval gunfire against waterborne cargo and coastal radar and gun battery sites.

**7 Sep 1968:** VA-52 deployed aboard *Coral Sea* (CVA 43). This was the first A-6 Intruder deployment aboard a *Midway* Class carrier.

**8 Dec 1970-23 Jun 1971:** During this period VA-52's main emphasis was on operations in Laos against the enemy's lines of communication and their transportation networks.

**23 Nov 1971:** Commander Lennart R. Salo became the first Naval Flight Officer to command an A-6 Intruder squadron.

**3 Apr 1972:** VA-52 commenced line operations from Yankee Station a few days earlier than scheduled as a result of the North Vietnamese invasion across the DMZ in South Vietnam on 30 March. During this line period heavy air raids were conducted against North Vietnam. These were the first major heavy air raids into North Vietnam since October 1968 and became known as operation Freedom Train.

**16 Apr 1972:** VA-52 conducted strikes in the Haiphong, Vinh, and Thanh Hoa as part of operation "Freedom Porch."

**9 May 1972:** Operation Pocket Money, the mining of Haiphong harbor, was launched. VA-52's Intruders took part in a diversionary attack at Phu Qui railroad yard while aircraft from *Coral Sea* conducted the actual mining.

**10 May 1972:** Linebacker I operations began and involved concentrated air strikes against targets in North Vietnam above the 20th parallel. During these operations VA-52's aircraft flew armed reconnaissance, Alpha strikes (large coordinated attacks), mine seeding operations, tanker operations, and standard arm sorties (use of antiradiation missiles to destroy missile radar sites).

**1-27 Jun 1972:** VA-52 flew special single aircraft night missions designated Sneaky Pete as part of Linebacker I operations.

**23 Nov 1973:** VA-52 deployed with CVW-11 aboard *Kitty Hawk* (CV 63) as part of the first CV concept air wing on the west coast. VA-52's Intruders were equipped with new ASW electronic equipment, the Multi-Channel Jezebel Relay pods.

**24-28 Jul 1979:** VA-52 and other elements of CVW-15, participated in search and assistance operations to aid Vietnamese boat people. A total of 114 people

were rescued through the efforts of the air wing and *Kitty Hawk*. These operations continued during August.

**27 Oct 1979:** South Korea's President Park Chung Hee was assassinated and *Kitty Hawk* immediately departed the Philippine Sea for the southwest coast of Korea, where they remained until 4 November.

**29 Dec 1979:** During operations off *Kitty Hawk*, the squadron's commanding officer, Commander Walter D. Williams, was lost at sea in a KA-6D.

**3 Dec 1979–23 Jan 1980:** After the assault on the American Embassy in Tehran and the taking of hostages on 4 November 1979, *Kitty Hawk* entered the Indian Ocean and operated in the Arabian Sea throughout this period.

**19 May 1981:** While transiting the South China Sea VA-52 aircraft spotted a small boat with 47 Vietnamese refugees on board and reported their location for rescue operations.

**10–12 Oct 1983:** *Carl Vinson* (CVN 70), with CVW-15 and VA-52, were kept on station in the Sea of Japan after the attempted assassination of South Korea's president.

**14–31 Aug 1986:** VA-52 participated in the first carrier operations in the Bering Sea since World War II. Most of the squadron's 400 hours and 200 sorties were made under adverse weather conditions.

**20–31 Jan 1987:** VA-52 conducted its second period of operations in the Northern Pacific and Bering Sea. At one point the most effective means of clearing snow and ice from *Carl Vinson's* flight deck was the jet exhaust from the squadron's aircraft.

**23 Sep 1987:** During night operations off *Carl Vinson* the squadron's Commanding Officer, Commander Lloyd D. Sledge, was lost at sea.

**Aug 1988:** The squadron flew sorties in support of Earnest Will operations, the escorting of reflagged Kuwait tankers in the Persian Gulf.



*Squadron F4U-4 Corsairs launch from Boxer (CV 21) during a combat deployment to Korea in 1951.*

**Home Port Assignments**

<i>Location</i>	<i>Date of Assignment</i>
NAS Olathe	01 Nov 1949
NAS San Diego	28 Jul 1950
NAS Miramar	Mar 1953
NAS Moffett Field	15 Jan 1962
NAS Alameda	29 Aug 1963
NAS Whidbey Island	01 Jul 1967

**Commanding Officers**

	<i>Date Assumed Command</i>
LCDR Glenn F. Carmichael	01 Nov 1949
LCDR Gordon E. Hartley	May 1951
LCDR Frederick W. Bowen	07 Mar 1952
LCDR Robert E. McElwee	08 Nov 1952
LCDR John C. Coulthard	Jan 1953
LCDR Dallas E. Runion	Jul 1954
CDR Gerald A. Robinson	Mar 1956
CDR Donald Michie	09 Aug 1957
CDR A. S. Taddeo	24 Feb 1959
CDR A. R. English	28 Oct 1960
CDR M. E. Beaulieu	30 Jan 1962
CDR Raymond W. West	17 Jan 1963
CDR George H. Edmondson	09 Jan 1964
CDR Lee T. McAdams	29 Dec 1964
CDR John C. Mape	10 Dec 1965
CDR Robert R. Worchesek	19 Apr 1966
CDR Lester W. Berglund, Jr.	30 Jun 1967
CDR James A. McKenzie	20 Jan 1969
CDR Robert H. Kobler	29 Jan 1970
CDR Douglas R. McCrimmon	20 Nov 1970
CDR Lennart R. Salo	23 Nov 1971
CDR Charles H. Kinney	03 Oct 1972
CDR Robert S. Owen	02 Oct 1973
CDR Clifton E. Banta	17 Jan 1975
CDR Daryl L. Kerr	23 Apr 1976
CDR William R. Galbraith	20 May 1977

**Commanding Officers—Continued**

	<i>Date Assumed Command</i>
CDR James R. McGuire	25 Aug 1978
CDR Walter D. Williams	08 Nov 1979
CDR Peter A. Rice	29 Dec 1979
CDR David T. Waggoner	09 May 1981
CDR Bruce V. Wood	27 Aug 1982
CDR Donald L. Sullivan	10 Feb 1984
CDR James M. Burin	26 Jul 1985
CDR Lloyd D. Sledge	08 Dec 1986
CDR Richard P. Dodd	23 Sep 1987
CDR Timothy Thomson	31 Mar 1989
CDR James M. Zortman	05 Oct 1990

**Aircraft Assignment**

<i>Type of Aircraft</i>	<i>Date Type First Received</i>
F8F-1	*
F4U-4	01 Aug 1950
F9F-5	Apr 1953
F9F-4 and F9F-6	†
F9F-8B	Apr 1956
F9F-8	Aug 1956
AD-5	Dec 1958
AD-6‡	Dec 1958
AD-7§	Mar 1959
A-6A	10 Nov 1967
A-6B	Oct 1970
KA-6D	**
A-6E	Jul 1974

\* The squadron was not assigned aircraft before its call to active duty. Pilots trained in and flew F8F-1s that were assigned to the air station where the squadron was home ported.

† The squadron operated a few of these models in the mid 1950s.

‡ AD-6 designation was changed to A-1H in 1962.

§ AD-7 designation was changed to A-1J in 1962.

\*\* The KA-6Ds were received some time between September and December 1971.



*VF-144's F9F-8 Cougar on the flight line at NAS Miramar, California, in 1957.*



**Major Overseas Deployments**

<i>Date of Departure</i>	<i>Date of Return</i>	<i>Air Wing</i>	<i>Carrier</i>	<i>Type of Aircraft</i>	<i>Area of Operation</i>
02 Mar 1951	24 Oct 1951	CVG-101	CV 21	F4U-4	WestPac/Korea
11 Aug 1952	17 Mar 1953	CVG-101	CVA 33	F4U-4	WestPac/Korea
03 Feb 1954	06 Aug 1954	CVG-14	CVA 15	F9F-5	Med
Jun 1955	03 Feb 1956	CVG-14	CVA 21	F9F-5	WestPac
21 Jan 1957	25 Jul 1957	CVG-14	CVA 12	F9F-8	WestPac
20 Jun 1958	20 Aug 1958	CVG-14	CVA 61	F9F-8	SoLant/SoPac
05 Mar 1960	10 Oct 1960	CVG-5	CVA 14	AD-6	WestPac
10 May 1961	15 Jan 1962	CVG-5	CVA 14	AD-6	WestPac
21 Jul 1962	11 Sep 1962	CVG-5*	CVA 16	AD-6/7	SoPac/SoLant
03 Jan 1963	16 Jul 1963	CVG-5	CVA 14	A-1H/J	WestPac/NorPac
13 Apr 1964	06 Dec 1964	CVW-5	CVA 14	A-1H/J	WestPac
28 Sep 1965	13 May 1966	CVW-5	CVA 14	A-1H/J	WestPac/Vietnam
15 Oct 1966	29 May 1967	CVW-19	CVA 14	A-1H/J	WestPac/Vietnam
07 Sep 1968	18 Apr 1969	CVW-15	CVA 43	A-6A	WestPac/Vietnam
06 Nov 1970	17 Jul 1971	CVW-11	CVA 63	A-6A/B	WestPac/Vietnam
17 Feb 1972	28 Nov 1972	CVW-11	CVA 63	A-6A/B & KA-6D	WestPac/Vietnam
23 Nov 1973	09 Jul 1974	CVW-11	CV 63	A-6A & KA-6D	WestPac/IO
21 May 1975	15 Dec 1975	CVW-11	CV 63	A-6E & KA-6D	WestPac
25 Oct 1977	5 May 1978	CVW-11	CV 63	A-6E & KA-6D	WestPac
30 May 1979	25 Feb 1980	CVW-15	CV 63	A-6E & KA-6D	WestPac/IO
01 Apr 1981	23 Nov 1981	CVW-15	CV 63	A-6E & KA-6D	WestPac/IO
01 Mar 1983	29 Oct 1983	CVW-15	CVN 70	A-6E & KA-6D	World Cruise
18 Oct 1984	24 May 1985	CVW-15	CVN 70	A-6E & KA-6D	WestPac/IO
12 Aug 1986	05 Feb 1987	CVW-15	CVN 70	A-6E & KA-6D	NorPac/WestPac/IO
15 Jun 1988	14 Dec 1988	CVW-15	CVN 70	A-6E & KA-6D	NorPac/WestPac/IO
05 Sep 1989	09 Nov 1989	CVW-15	CVN 70	A-6E & KA-6D	NorPac
01 Feb 1990	31 Jul 1990	CVW-15	CVN 70	A-6E & KA-6D	WestPac/IO

\* Only two squadrons from CVG-5 were aboard *Lexington* for her transfer cruise from the Pacific Fleet to the Atlantic Fleet.



A squadron A-1H Skyraider in 1966. The squadron began its active duty in prop planes, then transitioned to F9F jets in 1953 and returned to props when it received its first Skyraiders in 1958 (Courtesy Robert Lawson Collection).

**Air Wing Assignments**

<i>Air Wing</i>	<i>Tail Code</i>	<i>Assignment Date</i>
CVG-101	A	28 Jul 1950
CVG-14*	A	04 Feb 1953
CVG-14	NK†	1957
CVG-5/CVW-5‡	NF	26 Sep 1958
CVW-19§	NM	25 Aug 1966
COMFAIRWHIDBEY		01 Jul 1967
CVW-15	NL	Jun 1968
CVW-11	NH	**
CVW-15	NL	01 Jul 1978

\* CVG-101, a reserve carrier air group, was redesignated CVG-14 on 4 February 1953.

† CVG-14's tail code was changed from A to NK in the latter part of 1957. The effective date was most likely the beginning of FY 58 (1 July 1957).

‡ Carrier Air Groups were redesignated Carrier Air Wings on 20 December 1963, hence, CVG-5 became CVW-5.

§ On 1 July 1967, VA-52 detached from CVW-19 and moved to their new home port at NAS Whidbey Island to transition from the A-1 to the A-6.

\*\* The squadron was assigned to CVW-11 sometime in late 1969 or early 1970.

**Unit Awards Received**

<i>Unit Award</i>	<i>Inclusive Dates Covering Unit Award</i>	
KPUC	26 Mar 1951	08 Oct 1951
	17 Sep 1952	23 Feb 1953
	11 Aug 1964	22 Sep 1964
	07 Oct 1964	29 Oct 1964
	02 Nov 1964	06 Nov 1964
AFEM	21 Nov 1964	28 Nov 1964
	05 May 1990	01 Jun 1990
	17 May 1981	
HSM	02 Oct 1981	
	13 Nov 1979	08 Feb 1980
MUC	10 Nov 1984	07 May 1985

**Unit Awards Received—Continued**

<i>Unit Award</i>	<i>Inclusive Dates Covering Unit Award</i>	
NAVE	01 Oct 1987	15 Dec 1988
	01 Jul 1983	31 Dec 1984
NEM	01 Jul 1971	31 Dec 1972
	25 Nov 1979	28 Jan 1980
NUC	25 May 1981	30 Sep 1981
	02 Aug 1964	05 Aug 1964
RVNGC	10 Oct 1968	31 Mar 1969
	07 Dec 1970	24 Jun 1971
VNSM	09 Mar 1972	04 Nov 1972
	01 Sep 1968	01 Apr 1969
VNSM	05 Nov 1965	01 Dec 1965
	22 Dec 1965	14 Jan 1966
VNSM	22 Jan 1966	16 Feb 1966
	06 Mar 1966	31 Mar 1966
VNSM	10 Apr 1966	21 Apr 1966
	12 Nov 1966	18 Dec 1966
VNSM	03 Jan 1967	07 Feb 1967
	13 Feb 1967	16 Mar 1967
VNSM	28 Mar 1967	28 Apr 1967
	29 Dec 1968	30 Jan 1969
VNSM	08 Feb 1969	02 Mar 1969
	19 Mar 1969	30 Mar 1969
VNSM	07 Dec 1970	30 Dec 1970
	12 Jan 1971	04 Feb 1971
VNSM	19 Feb 1971	01 Mar 1971
	09 Apr 1971	26 Apr 1971
VNSM	03 May 1971	17 May 1971
	29 May 1971	23 Jun 1971
VNSM	08 Mar 1972	25 Mar 1972
	03 Apr 1972	22 May 1972
VNSM	01 Jun 1972	27 Jun 1972
	07 Jul 1972	04 Aug 1972
VNSM	14 Aug 1972	05 Sep 1972
	15 Sep 1972	02 Oct 1972
VNSM	12 Oct 1972	31 Oct 1972



A squadron A-6E Intruder in 1984. Notice the lance and knight helmet markings taken from the squadron's insignia.

## VA-54

### Lineage

Established as Scouting Squadron TWO B (VS-2B) on 3 July 1928.

Redesignated Scouting Squadron THREE (VS-3) on 1 July 1937.

Redesignated Bombing Squadron FOUR (VB-4) on 1 March 1943.

Redesignated Bombing Squadron FIVE (VB-5) on 15 July 1943.

Redesignated Attack Squadron FIVE A (VA-5A) on 15 November 1946.

Redesignated Attack Squadron FIFTY FOUR (VA-54) on 16 August 1948.

Disestablished on 1 December 1949. The first squadron to be assigned the VA-54 designation.

### Squadron Insignia and Nickname

The squadron's first insignia was approved by BuAer prior to the squadron's winter cruise in 1930. A pointing bird dog was adopted to reflect the duties as a scouting squadron. The dog was black with white spots and white outlines highlighting the dog's features.



As a scouting squadron, the pointing bird dog was an appropriate design for the squadron's first insignia.

In 1933, VS-2B reversed the color for the dog, giving it an overall white color with black markings. This insignia was used by the squadron following its redesignations to VS-3 in 1937, VB-4 in March

1943 and VB-5 in July 1943. On 24 October 1945, CNO approved a new insignia for VB-5. It was a modification of an insignia used by a previous VB-5 squadron



The squadron's pointing bird dog insignia was modified in 1933 when the colors of the dog were reversed.



During World War II, the squadron adopted this insignia to keep it in line with its mission as a bombing squadron.



Following World War II, the squadron adopted this insignia.

that had been in existence prior to World War II. It was a winged devil's head with a red ball of fire and a black bomb with red markings. The devil's helmet and beard were black; the face and horn was red; yellow goggles and mustache; and red wings outlined in black.

CNO approved a change to the squadron insignia on 3 June 1946. The new insignia had a yellow circle with a green bomb, outlined in black, with a red tip on the bomb. Overlaying the bomb were four aces and the joker. The playing cards had a white background, outlined in black, with the aces in the appropriate colors, while the joker was black with red eyes and mouth. The five cards signified the squadron's number. The squadron continued to use the insignia when it was redesignated VA-54.

Nickname: unknown.

### Chronology of Significant Events

**Jan-Feb 1929:** Fleet Problem IX was the first time the Navy's two large carriers, *Saratoga* (CV 3) (with VS-2B embarked) and *Lexington* (CV 2), participated in a major fleet exercise.

**Mar-Apr 1930:** In March, Fleet Problem X was conducted in the Caribbean Sea, followed by Fleet Problem XI in April.

**May 1930:** VS-2B's aircraft joined with the planes from 9 other squadrons, which included *Saratoga*, *Lexington* and *Langley* Air Groups, for a three-day tour of east coast cities from Norfolk, Virginia to Boston. The flight was commanded by Captain Kenneth Whiting and consisted of 36 torpedo and bombing planes, 57 fighting planes, 24 scouting planes, 3 amphibian utility planes, 3 Ford tri-motored transports and 2 staff planes. It was the largest air parade that had ever been assembled on the east coast.

**5 Nov 1931:** The squadron's commanding officer, Lieutenant Commander Oscar W. Erickson, was killed in an airplane crash at sea.

**1931-1934:** The squadron participated in Fleet Problems XII through XIX.

**31 May 1934:** A fleet review for President Franklin D. Roosevelt was held in New York Harbor.

**1935-1938:** The squadron participated in Fleet Problems XVI through XV.

**Apr-May 1940:** The squadron participated in Fleet Problem XXI. This was the last major fleet problem conducted before Pearl Harbor and America's involvement in World War II.

**Aug 1942:** VS-3 and the other squadrons in *Saratoga* Air Group provided air support for the landings on Guadalcanal.

**24–25 Aug 1942:** VS-3 participated in the Battle of Eastern Solomons and, along with other squadrons in the *Saratoga* Air Group, attacked and sunk the Japanese carrier *Ryujo*. Enroute back to *Saratoga* after their attack on the *Ryujo*, Lieutenant Commander Kirn, and ten of his SBDs attacked a Japanese flight of four Vals (Aichi D3A, Japanese Navy Type 99 Carrier Bombers), downing three and damaging the fourth.

**Sep–Nov 1942:** VS-3 operated from Espiritu Santo, New Hebrides until its return to CONUS in December.

**6–24 Jul 1943:** VB-5 departed Norfolk embarked in *Yorktown* (CV 10) enroute to Hawaii via the Panama Canal.

**31 Aug 1943:** VB-5, embarked in *Yorktown*, participated in a raid on Marcus Island.

**5–6 Oct 1943:** The squadron participated in a raid on Wake Island.

**Nov–Dec 1943:** VB-5 participated in operations against the Gilberts in support of the landings on Makin and Tarawa, as well as strikes against the Marshalls.

**Jan–Feb 1944:** The squadron flew strikes against the Marshall Islands and provided air support for the invasion of the Marshalls.

**16–17 Feb 1944:** VB-5, along with other squadrons in Air Group 5, flew strikes against the the Japanese stronghold of Truk.

**22 Feb 1944:** CVG-5's aircraft, including VB-5, raided the Marianas striking targets on Saipan.

**30 Mar–1 Apr 1944:** VB-5's SBDs struck ships and facilities at Palau in the Caroline Islands.

**21–23 Apr 1944:** Strikes were flown by VB-5 against targets on Wade Island and Hollandia in New Guinea. These operations were in support of the landings at Hollandia by General Douglas MacArthur's forces.

**29–30 Apr 1944:** VB-5 conducted another strike operation against Truk.

**14 May 1944:** Following a ten-month combat tour, which began in August 1943, Air Group 5 was relieved aboard *Yorktown* by Air Group 1 and the Air Group, including VB-5, returned to CONUS.

**07 Feb 1945:** CVG-5, with VB-5, embarked in *Franklin* (CV 13) and departed NAS Alameda for Hawaii, arriving there on 13 February. This was the beginning of the squadron's third major combat tour in the Pacific.

**19 Mar 1945:** Following the launch of CVG-5 aircraft, including SB2Cs from VB-5, for an attack against the city of Kobe, Japan, the *Franklin* was hit by two enemy bombs from a Japanese aircraft. Fires were ignited on the second and third decks from the first bomb and the second triggered munitions on the carrier. All CVG-5's aircraft still on the carrier were destroyed. The damage was one of the most extensive experienced by an *Essex* class carrier during World War II. A total of 724 were

killed and 265 wounded. However, the crew's heroic efforts saved the ship. CVG-5 personnel were transferred to *Sante Fe* (CL 60). CVG-5 aircraft in the air landed on other carriers, primarily *Bennington* (CV 20). Personnel in the water were picked up by destroyers.

**May 1949:** VA-54 was the last fleet squadron to operate the SB2C aircraft. The squadron completed its Operational Readiness Inspection on 19 May and the last operational flight of the SB2C.



*This photo shows a squadron O2U laying a smoke screen.*

### Home Port Assignments

<i>Location</i>	<i>Assignment Date</i>
NAS San Diego	03 Jul 1928
Espiritu Santo, New Hebrides	Sep 1942*
NAS San Diego	Dec 1942
MCAS El Centro	Jan 1943
NAS San Diego	Mar 1943
NAS Norfolk	Apr 1943
NAS Pearl Harbor	Jul 1943*
NAS Barbers Point	Sep 1943*
NAS Puunene	Oct 1943*
NAS Hilo	Dec 1943*
NAS Kaneohe	Dec 1943*
NAS Alameda	25 Jun 1944
NAAS Fallon	25 Jul 1944
NAAS Vernalis	29 Oct 1944
NAAS Santa Rosa	10 Nov 1944
Hawaii	Feb 1945*
NAS Klamath Falls	08 May 1945
NAS Pasco	28 Sep 1945
NAAS Brown Field	03 Dec 1945
NAS Barbers Point	25 Mar 1946
NAS San Diego	20 May 1946
NAS Seattle	13 Jan 1947
NAS San Diego	20 Mar 1947

\* Temporary shore assignment during World War II.



*This is a close-up view of the squadron O2U laying a smoke screen.*



*Squadron SU aircraft are parked on the forward flight deck of Lexington (CV 2) as she passes through the Panama Canal.*

**Commanding Officers**

	<i>Date Assumed Command</i>
LT Forrest P. Sherman (acting)*	03 Jul 1928
LCDR Virgil C. Griffin	03 Jul 1928
LT Forrest P. Sherman (acting)	Apr 1929
LCDR Dewitt C. Watson	21 Jun 1929
LCDR Adolph P. Schneider	01 Jun 1931
LCDR Oscar W. Erickson	17 Aug 1931
LT Robert P. McConnell (acting)	05 Nov 1931
LCDR Gordon Rowe	Jun 1932
LCDR Theodore C. Lonquest	Dec 1932
LT Harold M. Martin (acting)	Jul 1932
LCDR Felix B. Stump	13 Jul 1934
LCDR John F. Gillon	Jun 1936
LCDR Frederick W. McMahon	Jun 1937
LCDR Charles F. Greber	Jun 1938
LCDR Robert C. Sutliff	†
LCDR Sutlia	03 Apr 1941
LCDR Herbert L. Hoerner	01 Oct 1941
LCDR Louis J. Kirn	May 1942
LCDR Robert M. Milner	Mar 1943
LCDR Edgar E. Stebbins	Sep 1943
LT Charles P. Mason	25 Jun 1944
LCDR John G. Sheridan	02 Jul 1944
LT Harold W. Calhoun (acting)	15 May 1945

**Commanding Officers—Continued**

	<i>Date Assumed Command</i>
LTJG F. D. Brunner (acting)	31 May 1945
LCDR Paul J. Knapp	25 Jun 1945
LT Eugene M. Yoder (acting)	28 Aug 1945
LTJG H. M. Ziskin (acting)	07 Sep 1945
LCDR Howard L. Grimmell (acting)	08 Sep 1945
LCDR Allen L. Lewis (acting)	07 Nov 1945
LCDR Allen L. Lewis	05 Dec 1945
CDR Walter F. Madden	04 Oct 1947
LCDR Willard L. Nyburg (acting)	21 Jun 1948
CDR Edgar S. Keats	27 Jul 1948
LCDR R. A. Newcomb	04 Feb 1949
LCDR D. K. English	08 Apr 1949

\* Lieutenant Sherman was the senior officer assigned to the squadron during its establishment ceremonies. Following the establishment ceremonies Lieutenant Commander Griffin reported aboard and became the commanding officer.

† Assumed command sometime between October 1939 and June 1940.



*A formation of squadron SUs, circa 1933.*

**Aircraft Assignment**

<i>Type of Aircraft</i>	<i>Date Type First Received</i>
UO	Jul 1928
FU-1	27 Aug 1928
O2U-1	Dec 1928
O2U-2	Dec 1928
O3U-2	Dec 1931
SU-1	May 1932
SU-3	Nov 1932
SU-2	Dec 1932
SBU-1	Jan 1936
SBC-3	Aug 1937
SBC-4	Mar 1941
SBD-3	Aug 1941

**Aircraft Assignment**

<i>Type of Aircraft</i>	<i>Date Type First Received</i>
SBD-4	Jan 1943
SB2C	Apr 1943
SBD-5	Jun 1943
SB2C-3	25 Jun 1944
SBW-3	25 Jun 1944
SB2C-4	Sep 1944
SB2C-4E	Dec 1944
SB2C-5*	Mar 1946
F4U-4	19 Apr 1948
AD-1	May 1949
AD-4	Oct 1949

\* The squadron continued to operate the SB2C-5s until May 1949.

**Major Overseas Deployments**

<i>Date of Departure</i>	<i>Date of Return</i>	<i>Air Wing</i>	<i>Carrier</i>	<i>Type of Aircraft</i>	<i>Area of Operation</i>
15 Jan 1929	Mar 1929	<i>Saratoga</i> Air Group	CV 3	O2U-2	Central America/ Pacific
15 Feb 1930	21 Jun 1930	<i>Saratoga</i> Air Group	CV 3	O2U-2	Pacific/Carib
05 Feb 1931	15 Apr 1931	<i>Saratoga</i> Air Group	CV 3	O2U-2	Pacific/Carib
Feb 1932	19 Mar 1932	<i>Saratoga</i> Air Group	CV 3	O3U-2	Hawaii
23 Jan 1933	17 Feb 1933	<i>Saratoga</i> Air Group	CV 3	SU-1/2/3	Hawaii



*A formation of squadron SBC-3s in 1938 (Courtesy Robert Lawson Collection).*

**Major Overseas Deployments**

<i>Date of Departure</i>	<i>Date of Return</i>	<i>Air Wing</i>	<i>Carrier</i>	<i>Type of Aircraft</i>	<i>Area of Operation</i>
09 Apr 1934	09 Nov 1934	<i>Saratoga</i> Air Group	CV 3	SU-1/2/3	Pacific/Carib/ East Coast
May 1935	Jun 1935	<i>Saratoga</i> Air Group	CV 3	SU-2/3	Hawaii/NorPac
Apr 1936	Jun 1936	<i>Saratoga</i> Air Group	CV 3	SBU-1	Central America Pacific
Apr 1937	May 1937	<i>Saratoga</i> Air Group	CV 3	SBU-1	Hawaii
15 Mar 1938	Apr 1938	<i>Saratoga</i> Air Group	CV 3	SBC-3	Hawaii
02 Apr 1940	21 Jun 1940	<i>Saratoga</i> Air Group	CV 3	SBC-3	Hawaii
08 Dec 1941	19 Feb 1942	<i>Saratoga</i> Air Group	CV 3*	SBD-3	Hawaii
07 Jul 1942	Sep 1942	<i>Saratoga</i> Air Group	CV 3†	SBD-3	SoPac
22 Aug 1943	07 Sep 1943	CVG-5	CV 10	SBD-5	Pacific
29 Sep 1943	11 Oct 1943	CVG-5	CV 10	SBD-5	Pacific
10 Nov 1943	09 Dec 1943	CVG-5	CV 10	SBD-5	Pacific
16 Jan 1944	11 May 1944	CVG-5	CV 10	SBD-5	Pacific
03 Mar 1945	19 Mar 1945	CVG-5	CV 13	SB2C-4E	Pacific
31 Mar 1947	16 Jun 1947	CVG-5	CV 38	SB2C-5	WestPac

\* The squadron was operating from *Saratoga* in the Hawaiian area when, on 11 January 1942, the ship was hit by a torpedo from a Japanese submarine. With VS-3 aboard, *Saratoga* departed Hawaii and returned to Bremerton, Washington, for repairs. The other squadrons in *Saratoga's* Air Group remained in Hawaii.

† *Saratoga* was torpedoed for a second time on 31 August 1942 and VS-3 was transferred ashore at Espiritu Santo in early September.



A close-up view of a squadron SBC-3 in flight. Part of the squadron's pointing bird dog insignia is visible on the fuselage just below the pilot.

### Air Wing Assignments

<i>Air Wing</i>	<i>Tail Code</i>	<i>Assignment Date</i>
Saratoga Air Group*		Jul 1928
†		Sep 1942
CVG-5	S‡	15 Feb 1943

\* Squadrons assigned to the carriers prior to 1 July 1938 were part of that carrier's air group. However, it was not until 1 July 1938, when air group commander billets were established, that the air groups themselves became official organizations.

† When VS-3 was transferred ashore at Espiritu Santo, New Hebrides, from *Saratoga* the squadron's association with the *Saratoga* Air Group came to an end.

‡ CVG-5 aircraft were assigned the tailcode S on 12 December 1946.



Squadron SB2C-5 Helldivers fly over Boulder Dam in 1948.



**Unit Awards Received**

<i>Unit Award</i>	<i>Inclusive Dates Covering Unit Award</i>	
PUC	31 Aug 1943	
	05 Oct 1943	06 Oct 1943
	19 Nov 1943	05 Dec 1943
	29 Jan 1944	23 Feb 1944
	29 Mar 1944	30 Apr 1944
NAVE	01 Jul 1947	30 Jun 1948
Campaign Medal (Asiatic/Pacific)	07 Aug 1942	09 Aug 1942
	23 Aug 1942	25 Aug 1942

**Unit Awards Received—Continued**

<i>Unit Award</i>	<i>Inclusive Dates Covering Unit Award</i>	
PUC	31 Aug 1943	
	05 Oct 1943	06 Oct 1943
	19 Nov 1943	04 Dec 1943
	29 Jan 1944	08 Feb 1944
	16 Feb 1944	17 Feb 1944
NAVE	21 Feb 1944	22 Feb 1944
	30 Mar 1944	01 Apr 1944
Campaign Medal (Asiatic/Pacific)	21 Apr 1944	24 Apr 1944
	29 Apr 1944	01 May 1944



*A squadron AD-1 Skywarrior loaded with dud rockets and general purpose bombs. The squadron's joker and card insignia and Battle E award are on the fuselage just forward of the pilot.*

## SECOND VA-54

### Lineage

Established as Bomber Fighter Squadron ONE HUNDRED FIFTY THREE (VBF-153) on 26 March 1945.

Redesignated Fighter Squadron SIXTEEN A (VF-16A) on 15 November 1946.

Redesignated Fighter Squadron ONE HUNDRED FIFTY TWO (VF-152) on 15 July 1948.

Redesignated Fighter Squadron FIFTY FOUR (VF-54) on 15 February 1950.

Redesignated Attack Squadron FIFTY FOUR (VA-54) on 15 June 1956.

Disestablished on 1 April 1958. The second squadron to be assigned the VA-54 designation.

### Squadron Insignia and Nickname

The squadron's first insignia was approved by CNO on 17 July 1945. The insignia was designed by Walt Disney Productions.



*The squadron's first insignia was designed by Walt Disney Productions.*

Colors for the dog on a winged bomb were: white background, pale yellow circle outline; blue powder head bomb with black body, blue middle fin, and bright orange corsair wings with white highlights; the dog was a mottled brown and black, jowls and chest a flesh color, nose black with white highlights, right eye ringed in black, eyeballs white, pupils blue with black centers, mouth black, and tongue red; boxing gloves orange; and collar black with blue loop and black leash.

Following the redesignation to VF-16A the squadron had a new insignia approved on 26 May 1948. Colors for the flying ace of spades were: black outer circle and red inner circle; black background; gold wings outlined in black; ace of spades and card markings were black; red bloodspots; copper arrowhead outlined in black. When the squadron was redesignated VF-152 it retained the flying ace of spades insignia.

A new squadron insignia was approved by CNO on 14 February 1951, a year after the squadron had been redesignated VF-54. The insignia's design was based on the statement "through Hell or High Water." Colors for this insignia were: sky blue background in the upper half and sapphire blue in the lower half of the insignia, the overall insignia outlined in black; a crimson devil's head was encircled by yellow, red and amber flames; the devil's features include black hair,



*The squadron's second insignia, approved in 1948, depicts the nickname "Copperheads."*



*The squadron's last insignia, the devil's head, gave them the nickname "Hell's Angels."*

eyebrows, mustache and highlights; his eyes were white with emerald pupils and vermilion iris; the mouth was white; and gold anchor, shield and wings. The squadron's motto was *Angeli Inferni* meaning Hell's Angels. When the squadron was redesignated VA-54 in 1956, it continued to use the Hell's Angels insignia.

Nickname: Copperheads, until 1951.

Hell's Angels, 1951–1958.

### Chronology of Significant Events

**29 Jun 1950:** VF-54 was deployed aboard *Valley Forge* (CV 45) in the Western Pacific when hostilities erupted in Korea on 25 June. The carrier was ordered north from the Philippines and the squadron's aircraft conducted a sweep along the western coast of Taiwan due to the concern that the North Korean invasion of South Korea might be a prelude to an invasion of that island by the Chinese Communists.

**3 Jul 1950:** The squadron participated in its first combat strikes since its establishment in 1945. These strikes were the first made by carrier aircraft in the Korean War. VF-54's Corsairs struck targets in Pyongyang, North Korea.

**15 Sep 1950:** VF-54 provided air support for the landings at Inchon, South Korea.

**26 Jul 1954:** VF-54's AD-4 Skyraiders were on a SAR mission looking for survivors, rafts or debris from a British Cathay Pacific DC-4 airliner, that had been shot down by the Chinese Communists, when they were attacked by two Chinese LA-7 fighter aircraft. Two of the squadron's Skyraiders, along with an F4U, shot down the two LA-7s 13 miles southeast of Hainan Island.

**Sep 1957:** *Bon Homme Richard* (CVA 31), with VA-54 embarked, operated in the vicinity of Taiwan in response to a buildup of Chinese Communist forces on the mainland opposite Taiwan.

**Dec 1957:** The squadron began the transition from propeller aircraft to jets.



*A squadron F6F-5 Hellcat in flight, circa 1947 (Courtesy Robert Lawson Collection).*

**Home Port Assignments**

<i>Location</i>	<i>Assignment Date</i>
NAS Wildwood	26 Mar 1945
NAAS Oceana	01 Jun 1945
NAS Norfolk	02 Jul 1946
NAS Alameda	11 Aug 1946
NAS Sand Point	04 May 1948
NAS Alameda	28 Jun 1948
NAS San Diego	01 Dec 1949
NAS Miramar	19 May 1952

**Commanding Officers**

	<i>Date Assumed Command</i>
LCDR Hayden M. Jensen	26 Mar 1945
LCDR Levern E. Forkner	01 May 1947
CDR Robert G. Boyd	09 Jul 1948
LCDR Douglas K. English	01 Dec 1949
LCDR Paul N. Gray	16 Jan 1951
LCDR Henry Suerstedt, Jr.	27 Jun 1952
LCDR Christian Fink	21 Jul 1953
CDR Donald E. Bruce	Dec 1954
CDR Frank M. McLinn	Sep 1955
CDR William A. Lewiston	Jun 1956
CDR Emmit W. Blackburn	16 Dec 1957



*A squadron F8F-1 Bearcat on the deck of Tarawa (CV 40) in 1948 (Courtesy Robert Lawson Collection).*

**Aircraft Assignment**

<i>Type of Aircraft</i>	<i>Date Type First Received</i>
F4U-1	26 Mar 1945
F4U-4	04 Jun 1945
F6F-5	10 Sep 1945
F8F-1	21 Oct 1947
F8F-2	May 1949
AD-4	01 Dec 1949
F4U-4B	14 Dec 1949
AD-1/4	Mar 1951
AD-6	Dec 1954*
AD-5	Dec 1954
AD-7	Jan 1957
F9F-8B	Dec 1957

\* VF-54 operated AD-6s for a short period of time between October and December 1953.

### Major Overseas Deployments

<i>Date of Departure</i>	<i>Date of Return</i>	<i>Air Wing</i>	<i>Carrier</i>	<i>Type of Aircraft</i>	<i>Area of Operation</i>
31 Mar 1947	08 Oct 1947	CVAG-15	CV 36	F6F-5	WestPac
01 May 1950	01 Dec 1950	CVG-5	CV 45	F4U-4B	WestPac/Korea
28 Jun 1951	25 Mar 1952	CVG-5	CV 9	AD-2/3/4	WestPac/Korea
20 Nov 1952	25 Jun 1953	CVG-5	CVA 45	AD-4	WestPac/Korea
12 Mar 1954	Nov 1954	CVG-5	CVA 47	AD-4	WestPac
29 Oct 1955	17 May 1956	CVG-5	CVA 33	AD-6	WestPac
12 Jul 1957	09 Dec 1957	CVG-5	CVA 31	AD-6/7	WestPac



*A squadron F4U-4B Corsair prepares to launch from Valley Forge (CV 45) during a combat deployment to Korea in 1950 (Courtesy Robert Lawson Collection).*



*A squadron AD-6 Skyraider coming in for a landing on Kearsarge (CVA 33) during its 1955–1956 WestPac deployment.*

### Air Wing Assignments

<i>Air Wing</i>	<i>Tail Code</i>	<i>Assignment Date</i>
CVG-153/CVAG-15/CVG-15*	B/A†	26 Mar 1945
CVG-5	S/NF‡	01 Dec 1949

\* CVG-153 was redesignated CVAG-15 on 15 November 1946 and then redesignated CVG-15 on 1 September 1948.

† CVAG-15 was assigned the tail code B on 12 December 1946. It was changed to A on 4 August 1948.

‡ CVG-5's tail code was changed from S to NF in the latter part of 1957. The effective date was most likely the beginning of FY 58 (1 July 1957).

**Unit Awards Received**

<i>Unit Award</i>	<i>Inclusive Dates Covering Unit Award</i>	
NAVE	01 Jul 1948	30 Jun 1949
NUC	03 Jul 1950	18 Nov 1950
	01 Jan 1953	05 Jun 1953
	21 Aug 1951	05 Mar 1952
KPUC	01 Jul 1950	18 Nov 1950

**Unit Awards Received—Continued**

<i>Unit Award</i>	<i>Inclusive Dates Covering Unit Award</i>	
KSM	30 Dec 1952	10 Jun 1953
	15 Aug 1951	11 Mar 1952
	30 Jun 1950	23 Nov 1950
	13 Aug 1951	01 Nov 1951



*Squadron F9F-8B Cougars on the flight line at NAS Miramar, California, in 1958.*

## VA-55

### Lineage

Established as Torpedo Squadron FIVE (VT-5) on 15 February 1943.

Redesignated Attack Squadron SIX A (VA-6A) on 15 November 1946.

Redesignated Attack Squadron FIFTY FIVE (VA-55) on 16 August 1948.

Disestablished on 12 December 1975. The first squadron to be designated VA-55.

### Squadron Insignia and Nickname

The squadron's first insignia was not submitted or approved by CNO. This insignia was a horned black cat, grasping a rat, astride a torpedo. The colors were: a red background with a black cat; the cat's face, claws and horns were red; the rat had a yellow face and a red body; the torpedo had a yellow nose and tail section with a red center and black markings; and the word Torpcats was black.



*This TORPCATS insignia was used by VT-5 during World War II but was never officially approved.*

On 10 July 1946, a new squadron insignia was approved by CNO. The insignia design was the face of a cat grasping a torpedo in its mouth. Colors were: a lemon yellow background; a blue cat's head with green eyes, gray jowls, black nose and whiskers, and white teeth; the torpedo was red with white highlights and outlined in black. This insignia was used by VT-5, VA-6A and VA-55 until September 1955.

On 27 September 1955 a new insignia was approved. The winged seahorse insignia was outlined by alternating white and dark green square blocks; the upper half of the insignia was turquoise and the lower half dark blue; the waves were highlighted in white; the seahorse was silver with gold wings and highlighted with black markings; the rocket was silver with red tail fins and nose, black markings, and a flame of red and yellow.



*This squadron insignia was approved for use in the post-World War II period, retaining the cat and torpedo motif.*

Nickname: Torpcats, 1943–1955.

Warhorses, 1955–1975.



*In the mid-1950s, the squadron adopted the seahorse insignia that became a well-known design.*

### Chronology of Significant Events

**15 Feb 1943:** VGS-30 was disestablished and personnel from the squadron were used to form VT-5 and VF-1.

**6–24 Jul 1943:** The squadron departed Norfolk embarked in *Yorktown* (CV 10) enroute to Hawaii via the Panama Canal.

**31 Aug 1943:** Embarked in *Yorktown*, the squadron participated in a raid on Marcus Island.

**5–6 Oct 1943:** The squadron participated in a raid on Wake Island.

**Nov-Dec 1943:** The squadron supported the landings on Makin and Tarawa, in the Gilberts, and flew strikes against Kwajalein in the Marshalls.

**Jan-Feb 1944:** The squadron provided air support for the invasion of the Marshalls.

**16–17 Feb 1944:** Squadron aircraft flew strikes against the Japanese stronghold of Truk.

**22 Feb 1944:** The squadron participated in a raid on the Marianas, striking targets on Saipan.

**30 Mar–1 Apr 1944:** Squadron aircraft struck ships and facilities at Palau in the Caroline Islands. The strike on 30 March was the first time the squadron's TBFs were armed with torpedoes in combat.

**21–23 Apr 1944:** Strikes were flown against targets on Wakde Island and Hollandia in New Guinea. These operations were in support of the landings at Hollandia by General Douglas MacArthur's forces.

**29–30 Apr 1944:** The squadron participated in another strike operation against Truk.

**30 Apr 1944:** The squadron's commanding officer, Lieutenant Commander Dick Upson, failed to return from a SAR mission to locate a downed pilot.

**14 May 1944:** Following a ten-month combat tour beginning in August 1943, Air Group 5 was relieved aboard *Yorktown* by Air Group 1 and returned to CONUS to reform on 25 June 1944.

**07 Feb 1945:** Embarked in *Franklin* (CV 13), the squadron departed NAS Alameda for Hawaii, arriving there on 13 February. This was the beginning of

the squadron's second major combat tour in the Pacific.

**19 Mar 1945:** VT-5 was preparing to launch its aircraft for an attack against the city of Kobe, Japan, when the *Franklin* was hit by two enemy bombs from a Japanese aircraft. Fires were ignited on the second and third decks from the first bomb and the second triggered munitions on the carrier. All VT-5's aircraft on the flight and hangar deck were destroyed by the ensuing explosions and fire. The damage was one of the most extensive experienced by an *Essex* class carrier during World War II. A total of 724 men were killed and 265 wounded. VT-5's commanding officer, Lieutenant Commander Edmands, was lost in the action. All surviving VT-5 personnel were transferred from *Franklin* and returned to CONUS.

**3 Jul 1950:** Participated in the first combat strikes by carrier aircraft against the North Koreans. The squadron flew its AD-4 Skyraiders on strikes against airfields, supply lines and transportation facilities in and around Pyongyang, North Korea. This was also the first use of the AD Skyraider in combat.

**12 Sep 1950:** Pre-invasion strikes against targets in and around Inchon and Seoul, Korea, began in preparation for the landing at Inchon.

**15 Sep 1950:** Strikes were flown to support the landings at Inchon.

**16 May 1951:** All VA-55 personnel, except 16 officers and 5 enlisted men, embarked USNS *General William Weigel* (TAP 119) enroute to Japan for duty with Air Group 19 aboard Princeton (CV 37). The remainder of the personnel were airlifted to Japan on 17 May.

**29 May 1951:** VA-55 embarked on *Princeton*, replaced VA-195 in Air Group 19, and proceeded to Korea for combat operations.

**Mar 1954:** The squadron was deployed to the Western Pacific aboard *Essex* (CVA 9) when the carrier was ordered to operate off the coast of Vietnam during the Viet Minh's assault against the French at Dien Bien Phu.

**Jul-Sep 1957:** Operated intermittently off the coast of Taiwan due to the build-up of Chinese Communist forces and the threat of a possible invasion of Taiwan or its off-shore islands.

**Sep 1958:** Operated in the Formosa Straits during the Chinese Communist shelling of Quemoy and Matsu.

**30-31 Oct 1962:** Participated in cross deck operations on HMS *Victorious* (R 38) in the South China Sea.

**Apr 1963:** *Ticonderoga*, with VA-55 embarked,

deployed to the South China Sea following several defeats of neutralist forces by the Communists in Laos. After a ceasefire agreement was arranged, the ship resumed normal Seventh Fleet operations on 5 May.

**Jul-Sep 1964:** Participated in special Yankee Team operations involving missions over Laos and South Vietnam.

**2 and 4 Aug 1964:** The squadron flew air support for *Maddox* (DD 731) and *Turner Joy* (DD 951) while the destroyers were on Desoto Patrol missions (intelligence collection missions begun in 1962) off the coast of North Vietnam.

**5 Aug 1964:** VA-55's Skyhawks participated in operation Pierce Arrow, retaliatory strikes against the North Vietnamese. Along with other aircraft from CVG-5, they were part of the mission that struck the Vinh oil storage facility. Ninety percent of the complex was destroyed.

**Oct-Nov 1964:** The squadron continued to operate from *Ticonderoga* off the coast of South Vietnam and participated in special Yankee Team operations, flying missions over South Vietnam.

**3 Jun 1966:** The squadron's commanding officer, Commander M. J. Chewning, while on a mission over North Vietnam, lost the use of his left arm due to a shrapnel hit. He continued his mission, striking a road target, and then returned to the carrier, making a one-handed carrier landing. For his exploits he was awarded the Silver Star and the Purple Heart.

**15 Jun 1966:** Lieutenant Commander Theodore F. Kopfman was awarded the Silver Star, in absentia, for his actions on a mission over North Vietnam. During the sortie his aircraft was shot down and he was taken prisoner. He was released by North Vietnam and returned to the United States in 1973.

**Apr 1972:** The squadron participated in Operation Freedom Train, tactical air sorties against military and logistic targets in the southern part of North Vietnam. It also provided close air support for forces in South Vietnam following a massive invasion by North Vietnam.

**May 1972:** Participated in the early phase of operation Linebacker I, heavy air strikes against targets in North Vietnam.

**Jun 1973:** Missions were flown in support of Operation End Sweep, the clearing of mines in the territorial waters of North Vietnam.

**Oct 1973:** With the outbreak of war between Israel, Egypt and Syria, the *Hancock* (CVA 19), with VA-55 embarked, was directed to leave Yankee Station and operate in the Arabian Sea and Gulf of Aden.



*VT-5 flight crews in front of a squadron TBM-3. The squadron TORPCATS insignias on all the flight jackets, circa summer 1945.*

### **Home Port Assignments**

<i>Location</i>	<i>Assignment Date</i>
NAS Norfolk (NAAF Pungo)	15 Feb 1943
Hawaii	Jul 1943*
NAS Alameda	May 1944
NAAS Monterey	Aug 1944†
NAAS Santa Rosa	Oct 1944†
Hawaii	Feb 1945‡
NAS Seattle	Apr 1945§
NAS Klamath Falls	08 May 1945
NAS Pasco	02 Sep 1945
NAAS Brown Field, Chula Vista	04 Dec 1945
NAS Barbers Point	25 Mar 1946
NAS San Diego	21 May 1946
NAS Miramar	20 Mar 1952
NAS Lemoore	Jan 1962

\* Temporary shore assignments at various air stations in Hawaii when not aboard *Yorktown* (CV 10).

† Temporary shore station for the squadron while it conducted training in preparation for its next combat cruise.

‡ Temporary shore assignment in Hawaii when not aboard *Franklin* (CV 13), no specific air station listed.

§ Temporary shore station awaiting reforming of squadron in May 1945.

### **Commanding Officers**

	<i>Date Assumed Command</i>
LCDR Richard Upson	15 Feb 1943
LT Andrew C. Lett (acting)	30 Apr 1944
LCDR Allan C. Edmands	18 Jun 1944
LT Charles H. Carr (acting)	08 May 1945
LCDR Tom B. Bash	18 May 1945
LT John D. Cornwell (acting)	31 Aug 1945
LT William L. Dodd (acting)	12 Oct 1945
LCDR Allard G. Russell	21 Oct 1945
LCDR William A. Rawls (acting)	01 Oct 1947
CDR Charles H. Crabill, Jr.	24 Dec 1947



**Commanding Officers—Continued**

	<i>Date Assumed Command</i>
LCDR Norman D. Hodson	14 Jan 1949
LCDR A. L. Maltby, Jr.	17 Jan 1951
LCDR L. W. Chick	03 Oct 1951
LCDR Jack T. Dowler	Feb 1953
LCDR R. J. Thompson	Oct 1953
CDR Jack T. Dowler	Aug 1954
CDR Franklin V. Bernhard	Nov 1955
CDR Billy D. Holder	20 Mar 1957
CDR D. H. Stinemates	21 Feb 1958
CDR J. E. McQuary	06 Feb 1959
CDR H. M. Richey	13 Nov 1959
CDR Lloyd F. Cooper	23 Nov 1960
CDR Earl F. Godfrey	23 Feb 1962
CDR E. J. Lawrence	01 May 1963
CDR H. Urban, Jr.	01 May 1964
CDR J. E. Krimmel	28 May 1965
CDR M. J. Chewning	04 Apr 1966
CDR E. E. Holt (acting)	03 Jun 1966
CDR E. E. Holt	09 Aug 1966
CDR Robert E. Kirksey	17 Oct 1967
CDR John F. Wellings	18 Dec 1968
CDR Frederick W. Lawler	27 Sep 1969
CDR Richard A. Hendricks	27 Mar 1970
CDR Maurice D. Fitzgerald	1971

**Commanding Officers—Continued**

	<i>Date Assumed Command</i>
CDR George J. Fenzil, Jr.	03 Jun 1972
CDR P. M. Feran	1973
CDR Almer C. Vold	21 Jun 1974

**Aircraft Assignment**

<i>Type of Aircraft</i>	<i>Date Type First Received</i>
TBF-1	01 Mar 1943
TBF-1C	Oct 1943
TBM-3	Sep 1944
TBM-3E	Jun 1945
TBM-3Q	Oct 1946
TBM-3J	Mar 1947
AD-1	18 Jun 1949
AD-4	03 Oct 1949
AD-6	Jul 1954
AD-7	Dec 1956
FJ-4B	Nov 1957
A4D-2	Mar 1959
A4D-2N/A-4C*	Jan 1962
A-4E	Jul 1963
A-4C	12 Sep 1966
A-4F	29 Dec 1967

\* The A4D-2N designation was changed to A-4C in 1962.



*Squadron AD-4Q Skyraiders at NAS San Diego, California, in December 1950 following their return from a Korean combat tour aboard Valley Forge (CV 45) (Courtesy Robert Lawson Collection).*

**Major Overseas Deployments**

<i>Date of Departure</i>	<i>Date of Return</i>	<i>Air Wing</i>	<i>Carrier</i>	<i>Type of Aircraft</i>	<i>Area of Operation</i>
22 Aug 1943	07 Sep 1943	CVG-5	CV 10	TBF-1	Pacific
29 Sep 1943	11 Oct 1943	CVG-5	CV 10	TBF-1	Pacific
10 Nov 1943	09 Dec 1943	CVG-5	CV 10	TBF-1C	Pacific
16 Jan 1944	11 May 1944	CVG-5	CV 10	TBF-1C	Pacific
03 Mar 1945	19 Mar 1945	CVG-5	CV 13	TBF-3	Pacific
31 Mar 1947	16 Jun 1947	CVG-5	CV 38	TBM-3E/Q/J	WestPac
01 May 1950	01 Dec 1950	CVG-5	CV 45	AD-4/4Q	WestPac/Korea
16 May 1951	29 Aug 1951	CVG-19	CV 37*	AD-4/4Q/4W	WestPac/Korea
16 Jun 1952	06 Feb 1953	ATG-2	CVA 9	AD-4/4B	WestPac/Korea
01 Dec 1953	12 Jul 1954	ATG-2	CVA 9	AD-4/4B	WestPac
01 Apr 1955	23 Nov 1955	ATG-2	CVA 47	AD-6	WestPac
06 Apr 1957	18 Sep 1957	ATG-2	CVA 19	AD-6/7	WestPac
21 Aug 1958	12 Jan 1959	ATG-4	CVA 20	FJ-4B	WestPac
06 Mar 1960	11 Oct 1960	CVG-5	CVA 14	A4D-2	WestPac
10 May 1961	15 Jan 1962	CVG-5	CVA 14	A4D-2	WestPac
25 Jul 1962	17 Sep 1962	CVG-5	CVA 64	A4D-2	SoLant/West Coast
03 Jan 1963	15 Jul 1963	CVG-5	CVA 14	A-4C	WestPac
14 Apr 1964	15 Dec 1964	CVW-5	CVA 14	A-4E	WestPac/Vietnam
10 Dec 1965	25 Aug 1966	CVW-14	CVA 61	A-4E	WestPac/Vietnam
29 Apr 1967	04 Dec 1967	CVW-14	CVA 64	A-4C	WestPac/Vietnam
18 Jul 1968	03 Mar 1969	CVW-21	CVA 19	A-4F	WestPac/Vietnam
02 Aug 1969	15 Apr 1970	CVW-21	CVA 19	A-4F	WestPac/Vietnam
22 Oct 1970	03 Jun 1971	CVW-21	CVA 19	A-4F	WestPac/Vietnam
07 Jan 1972	03 Oct 1972	CVW-21	CVA 19	A-4F	WestPac/Vietnam
08 May 1973	08 Jan 1974	CVW-21	CVA 19	A-4F	WestPac/IO
18 Mar 1975	20 Oct 1975	CVW-21	CV 19	A-4F	WestPac

\* See chronology entry for 16 May 1951.

**Air Wing Assignments**

<i>Air Wing</i>	<i>Tail Code</i>	<i>Assignment Date</i>
CVG-5	S*	15 Feb 1943
CVG-19 (X)†		23 Apr 1951
CVG-19	B	29 May 1951
ATG-2	W/NB‡	11 Sep 1951
CVG-5	NF	01 Apr 1958
ATG-4	ND	18 Aug 1958
CVG-5/CVW-5§	NF	19 Jan 1959
CVW-14	NK	01 Jun 1965
CVW-21	NP	05 Feb 1968

\* The tail code S was assigned to the air group and squadron on 12 December 1946.

† The squadron was assigned to Air Group 19 (X-ray), an air group that was organized in CONUS and then sent to Japan to replace the squadrons in Air Group 19 which had been operating in Korea aboard *Princeton* (CV 37).

‡ ATG-2 was assigned the letter W as its tail code on 24 July 1956. The tail code was changed to NB in 1957. The effective date for this change was most likely the beginning of FY 58 (1 July 1957).

§ CVG-5 became CVW-5 when Carrier Air Group designations were changed to Carrier Air Wings on 20 December 1963.

**Unit Awards Received**

<i>Unit Award</i>	<i>Inclusive Dates Covering Unit Award</i>	
NAVE	01 Jul 1948	30 Jun 1949
	01 Jul 1949	30 Jun 1950
	1965	1966
AFEM	02 Aug 1964	05 Aug 1964
	11 Aug 1964	22 Sep 1964
	07 Oct 1964	29 Oct 1964
	02 Nov 1964	06 Nov 1964
	21 Nov 1964	28 Nov 1964
	02 Dec 1968	04 Dec 1968
	30 Oct 1969	
	03 Jan 1970	08 Jan 1970
	22 Feb 1970	25 Feb 1970
MUC	21 Aug 1969	31 Mar 1970
	20 Nov 1970	07 Mar 1971
NUC	02 Aug 1964	05 Aug 1964
	10 Jan 1966	06 Aug 1966
	18 May 1967	26 Nov 1967
	01 Aug 1968	22 Feb 1969
	08 Feb 1972	14 Sep 1972

**Unit Awards Received—Continued**

<i>Unit Award</i>	<i>Inclusive Dates Covering Unit Award</i>	
RVNGC	30 Mar 1972	15 Jul 1972
VNSM	15 Jan 1966	12 Feb 1966
	23 Feb 1966	22 Mar 1966
	30 May 1966	30 Jun 1966
	08 Jun 1967	11 Jun 1967
	18 Jun 1967	25 Jul 1967
	01 Aug 1967	03 Sep 1967
	25 Sep 1967	15 Oct 1967
	24 Oct 1967	12 Nov 1967
	23 Aug 1968	04 Sep 1968
	13 Sep 1968	15 Oct 1968
	23 Oct 1968	28 Nov 1968
	20 Dec 1968	15 Jan 1969
	29 Jan 1969	10 Feb 1969
	31 Aug 1969	24 Sep 1969
	03 Oct 1969	27 Oct 1969
	24 Nov 1969	17 Dec 1969
	18 Jan 1970	11 Feb 1970
	09 Mar 1970	26 Mar 1970
	19 Nov 1970	08 Dec 1970
	29 Dec 1970	15 Jan 1971
	23 Jan 1971	31 Jan 1971
	09 Mar 1971	10 Apr 1971
	17 Apr 1971	04 May 1971
07 Feb 1972	09 Mar 1972	
25 Mar 1972	02 May 1972	

**Unit Awards Received—Continued**

<i>Unit Award</i>	<i>Inclusive Dates Covering Unit Award</i>	
PUC	11 May 1972	01 Jun 1972
	12 Jun 1972	14 Jul 1972
	24 Jul 1972	17 Aug 1972
	27 Aug 1972	14 Sep 1972
	31 Aug 1943	
	05 Oct 1943	06 Oct 1943
	19 Nov 1943	05 Dec 1943
	29 Jan 1944	23 Feb 1944
	29 Mar 1944	30 Apr 1944
	31 Aug 1943	
Campaign Medal (Asiatic/Pacific)	05 Oct 1943	06 Oct 1943
	19 Nov 1943	04 Dec 1943
	29 Jan 1944	08 Feb 1944
	16 Feb 1944	17 Feb 1944
	21 Feb 1944	22 Feb 1944
	30 Mar 1944	01 Apr 1944
	21 Apr 1944	24 Apr 1944
	29 Apr 1944	01 May 1944
	17 Mar 1945	19 Mar 1945
	27 Jun 1950	03 Nov 1950
KSM	29 May 1951	16 Aug 1951
	26 Jul 1952	25 Jan 1953
UNSM	27 Jun 1950	03 Nov 1950
	29 May 1951	16 Aug 1951
	26 Jul 1952	25 Jan 1953



*A squadron A-4F Skyhawk piloted by Lieutenant Duncan, 14 February 1975.*

**SECOND VA-55****Lineage**

Established as Attack Squadron FIFTY FIVE (VA-55) on 7 October 1983.

Disestablished on 1 January 1991. The second squadron to be assigned the VA-55 designation.

**Squadron Insignia and Nickname**

The squadron adopted the insignia used by the first VA-55. It was approved by CNO on 12 May 1983. Colors for the flying seahorse were: alternating white and dark green square blocks outline the circular insignia; the upper half of the insignia was light blue and the lower half dark blue; the waves were highlighted in white; the seahorse was light gray-green with white and dark green markings; the wings were gold with dark green markings; the flames from the seahorse and rocket were red, outlined in yellow; and the rocket was white with a red tip.



*The squadron adopted the same flying seahorse insignia used by the first VA-55.*

Nickname: Warhorses, 1983–1991.

**Chronology of Significant Events**

**25 Mar 1986:** Due to the initiation of hostile fire by Libya on 24 March, a squadron aircraft attacked a Libyan Nanuchka II class guided missile patrol boat with Rockeye cluster bombs. The Libyan vessel was damaged by the attack and then sunk by a Harpoon strike from VA-85, an Intruder squadron operating from *Saratoga* (CV 60).

**14–15 Apr 1986:** Six of the squadron's Intruders participated in an attack against Benina Airfield at Benghazi, Libya. Numerous parked aircraft were destroyed and the surrounding hangars, support facilities, aircraft aprons, and other airfield equipment and vehicles were damaged. These strikes were in response to the involvement of Libyan trained terrorists in a specific incident (Berlin disco bombing in which American servicemen were killed).

**Aug–Sep 1989:** *Coral Sea* (CV 43), with VA-55 embarked, was ordered to operate off the coast of Lebanon following terrorist claims to have killed an American hostage, Lieutenant Colonel William R. Higgins, and the capture of Sheik Obeid from Lebanon by Israeli forces. The unstable situation in Lebanon ultimately led to the evacuation of the American Embassy. Squadron aircraft flew missions in support of the evacuation.

**22 Feb 1991:** The squadron held a disestablishment ceremony at NAS Oceana. It was officially disestablished on 1 January 1991.

**Home Port Assignment**

<i>Location</i>	<i>Assignment Date</i>
NAS Oceana	07 Oct 1983

**Commanding Officers**

	<i>Date Assumed Command</i>
CDR Stan W. Bryant	07 Oct 1983
CDR Robin Y. Weber	18 May 1985
CDR Warren C. Chewning	27 Jun 1986
CDR Ralph E. Suggs	07 Dec 1987
CDR John W. Henson	07 Jan 1989

**Aircraft Assignment**

<i>Type of Aircraft</i>	<i>Date Type First Received</i>
A-6E	25 Jan 1984
KA-6D	Feb 1984

**Major Overseas Deployments**

<i>Date of Departure</i>	<i>Date of Return</i>	<i>Air Wing</i>	<i>Carrier</i>	<i>Type of Aircraft</i>	<i>Area of Operation</i>
01 Oct 1985	19 May 1986	CVW-13	CV 43	A-6E/KA-6D	Med
29 Sep 1987	28 Mar 1988	CVW-13	CV 43	A-6E	Med
31 May 1989	30 Sep 1989	CVW-13	CV 43	A-6E	Med

**Air Wing Assignments**

<i>Air Wing</i>	<i>Tail Code</i>	<i>Assignment Date</i>
COMMATWING-1*		07 Oct 1983
CVW-13	AK	01 Mar 1984

\* Administratively assigned to Commander Medium Attack Wing ONE.

**Unit Awards Received**

<i>Unit Award</i>	<i>Inclusive Dates Covering Unit Award</i>	
NAVE	01 Jan 1985	31 Dec 1985
	01 Jan 1986	31 Dec 1986
NEM	20 Jan 1986	05 May 1986
NUC	02 Oct 1985	19 May 1986

**Unit Awards Received—Continued**

<i>Unit Award</i>	<i>Inclusive Dates Covering Unit Award</i>	
	23 Mar 1986	17 Apr 1986
AFEM	20 Jan 1986	05 May 1986

**Unit Awards Received—Continued**

<i>Unit Award</i>	<i>Inclusive Dates Covering Unit Award</i>	
	01 Jan 1985	31 Dec 1986
MUC	30 Mar 1988	30 Sep 1989



*A squadron A-6E Intruder; note the flying seahorse insignia on the tail.*

## VA-56

### Lineage

Established as Attack Squadron FIFTY SIX (VA-56) on 4 June 1956.

Disestablished on 31 August 1986. The first squadron to be assigned the VA-56 designation.

### Squadron Insignia and Nickname

The squadron's insignia was officially approved by CNO on 25 March 1957. A boomerang with a speed arrow and electron rings represented the squadron's capabilities as a jet attack squadron with modern electronic equipment. The circular insignia had a gold circumference outlined in dark blue, with a white background; a yellow boomerang outlined in dark blue and with white racing strips; dark blue speed arrow and stars; and the electron rings and banner lettering were black with a white banner outlined in dark blue and gold.



*The squadron's stylized insignia is an example of an excellent design that remained viable throughout the squadron's 30 years of history and numerous aircraft changes.*

Nickname: Boomerangs, 1957-circa 1958.

Champions, circa 1958-1986.

### Chronology of Significant Events

**25-31 Oct 1961:** VA-56 participated in Operation Crosstie with HMS *Victorious* (R-38), conducting flight operations from the deck of *Victorious* to evaluate the compatibility of USN/RN aircraft, armament, and handling facilities.

**16 Jul-15 Sep 1962:** The squadron was embarked in *Constellation* (CVA 64) during her transit from the East Coast, via Cape Horn, to her new home port on the West Coast.

**Jul 1964:** VA-56's A-4E Skyhawks participated in special Yankee Team operations, providing aerial refueling support and experimenting with the tactic of employing A-4Es as armed escorts for the RF-8 and RA-3 reconnaissance aircraft flying missions over Laos and South Vietnam to detect Communist military presence and operations.

**2-4 Aug 1964:** During a Desoto Patrol mission (intelligence collection missions begun in 1962) *Maddox* (DD 731) was attacked by three motor torpedo boats on 2 August off the coast of North Vietnam. Following this incident, the squadron flew sorties in support of the destroyers on Desoto Patrol.

**5 Aug 1964:** VA-56's Skyhawks participated in Pierce Arrow, retaliatory strikes against the North Vietnamese. Along with other aircraft from CVW-5, they were part of the first sortie that struck the anti-aircraft gun emplacements at the Vinh oil storage facility. Ninety percent of the complex was destroyed by the sorties flown against this facility. The squadron also participated in strikes against the Ben Thuy naval base, resulting in the sinking and destruction of several torpedo boats.

**10-29 Oct, 1-5 and 22-28 Nov 1964:** The squadron continued to participate in special Yankee Team operations off the coast of Vietnam.

**7 Feb 1966:** Lieutenant Commander Render Crayton was awarded the Silver Star (in absentia) for his actions while engaged in a combat mission over North Vietnam.

**10 Jun 1967:** The squadron's commanding officer, Commander Sherman, failed to return from a strike in North Vietnam and is now listed as missing in action, presumed dead.

**Jan-Feb 1968:** While embarked in *Enterprise* (CVAN 65) and en route to Yankee Station, the carrier was ordered to the Sea of Japan for operations following the seizure of *Pueblo* (AGER 2) by the North Koreans on 23 January.

**19 Jun 1968:** Lieutenant Commander Crater received the Silver Star for his actions in coordinating the successful night rescue of a downed F-4 crewman in North Vietnam. This action was part of the rescue operations in which Lieutenant Lassen, a helicopter pilot and not a member of VA-56, received the Medal of Honor for his exploits.

**1 Nov 1968:** The squadron's last A-4E Skyhawk was transferred and training began for the transition to the A-7 Corsair II.

**May 1972:** On 12 May *Midway* (CVA 41), with VA-56 embarked, shifted its operations from the area of An Loc, South Vietnam to targets in North Vietnam. It participated in the mining and interdiction of Haiphong Harbor and North Vietnam's extensive coastal waterway system. This was an extension of operation Pocket Money which was initiated on 9 May by squadrons from *Kitty Hawk* (CVA 63) and *Coral Sea* (CVA 43). It also participated in operation Linebacker I, the concentration of heavy strikes against targets in North Vietnam to interdict the flow of supplies into the country and reduce its ability to prosecute the war. Linebacker I operations lasted until 22 October.

**29-30 Apr 1975:** *Midway*, including elements of VA-56, participated in operation Frequent Wind, the evacuation of American citizens from Saigon, South Vietnam.

**Aug 1976:** VA-56, embarked in *Midway*, operated in Korean waters following the killing of two American officers in the DMZ by the North Koreans.

**Apr–May 1979:** *Midway*, with VA-56 embarked, deployed to the Gulf of Aden to relieve *Constellation* (CV 64) and maintain a U.S. carrier presence following the out break of fighting between North and South Yemen and the fall of the Shah of Iran.

**Oct 1979:** As a response to anti-American demonstrations in Iran, *Midway* and its air wing, including VA-56, were ordered to deploy to the Indian Ocean for the second time in 1979.

**Nov 1979–Feb 1980:** Following the Iranian seizure of the American Embassy in Teheran and the taking of American hostages on 4 November, *Midway* proceeded to the Gulf of Oman and remained on station until relieved in early February 1980.

**May–Jun 1980:** *Midway*, with VA-56 embarked, operated off the coast of Korea due to the civil unrest in South Korea and the massacre of several hundred people in the town of Kwangju.

**May 1986:** The squadron was reassigned to NAS Lemoore as a result of the change in CVW-5's composition from A-7 and F-4 aircraft to FA-18A. It began the transfer of its personnel and aircraft in preparation for the disestablishment of the squadron on 31 August.



A flight of squadron F9F-8 Cougars that deployed aboard *Bon Homme Richard's* (CVA 31) 1957 WestPac cruise.

**Home Port Assignments**

	<i>Location Assignment Date</i>
NAS Miramar	04 Jun 1956
NAS Lemoore	30 Jun 1961
NS Yokosuka/ <i>Midway</i> (CV 41)*	30 Jun 1973
NAS Lemoore	May 1986

\* Under the Overseas Home Port Program, VA-56 and CVW-5 were permanently based aboard *Midway* (CV 41) and home ported with the carrier at Naval Station Yokosuka, Japan. The home port was officially changed on 30 June 1973. However, *Midway* did not arrive in Japan until 5 October. Elements of VA-56, when not operating from *Midway*, were based ashore at NAF Atsugi or Misawa, Japan.

**Commanding Officers**

	<i>Date Assumed Command</i>
CDR Richard O. Devine	04 Jun 1956
CDR C. G. Mitchell	31 Dec 1957
LCDR R. L. Walker	10 Dec 1958
CDR R. McBride	05 Dec 1959
CDR W. H. Hoover	06 Jan 1961
CDR James A. Homyak	31 Jan 1962
CDR Donald L. Campbell	17 Mar 1963
CDR Wesley L. McDonald	10 Feb 1964
CDR William G. Nealon	23 Mar 1965
CDR Carl Ray Smith, Jr.	28 Feb 1966
CDR Peter W. Sherman	17 Mar 1967
CDR Ernest R. Seymour	14 Jun 1967
CDR John L. Nicholson, Jr.	31 Jul 1968
CDR Joseph E. Potosnak	11 Dec 1969
CDR John W. Weed	Oct 1970
CDR Neil L. Harvey	21 Aug 1971
CDR Walter Lewis Chatham	02 Aug 1972
CDR Charles G. Andres	03 Aug 1973
CDR Ronald N. Artim	30 Jul 1974
CDR Gary L. Starbird	26 Sep 1975
CDR Robert E. Smith	19 Dec 1976
CDR Roger P. Flower	30 Mar 1978
CDR Leon C. Bryant	19 Jun 1979
CDR Charles S. Mitchell IV	22 Aug 1980
CDR Edwin E. Shipe III	28 Dec 1981
CDR Garold S. McDaniel	22 Mar 1983
CDR Paul R. Statskey	25 Jul 1984
CDR J. R. Hutchison	24 Jan 1986

**Aircraft Assignment**

<i>Type of Aircraft</i>	<i>Date Type First Received</i>
F9F-3	Jun 1956
F9F-8B	Jul 1956
F9F-8	Oct 1956
FJ-4B	29 May 1958
A4D-1	23 Dec 1958
A4D-2/A-4B*	Apr 1959
A-4E	15 Jul 1963
A-4C	23 Jul 1966
A-4E	18 Aug 1967
A-7B	Jan 1969
A-7A	Mar 1973
A-7E	24 Apr 1977

\* The A4D-2 designation was changed to A-4B in 1962.



*A squadron A-4C Skyhawk with Enterprise markings, 1966.*

### **Major Overseas Deployments**

<i>Date of Departure</i>	<i>Date of Return</i>	<i>Air Wing</i>	<i>Carrier</i>	<i>Type of Aircraft</i>	<i>Area of Operation</i>
12 Jul 1957	09 Dec 1957	CVG-5	CVA 31	F9F-8	WestPac
06 Mar 1960	10 Oct 1960	CVG-5	CVA 14	A4D-2	WestPac
10 May 1961	15 Jan 1962	CVG-5	CVA 14	A4D-2	WestPac
03 Jan 1963	15 Jul 1963	CVG-5	CVA 14	A-4B	WestPac
14 Apr 1964	15 Dec 1964	CVW-5	CVA 14	A-4E	WestPac/Vietnam
28 Sep 1965	13 May 1966	CVW-5	CVA 14	A-4E	WestPac/Vietnam
19 Nov 1966	06 Jul 1967	CVW-9	CVAN 65	A-4C	WestPac/Vietnam
03 Jan 1968	18 Jul 1968	CVW-9	CVAN 65	A-4E	WestPac/Vietnam
14 Oct 1969	01 Jun 1970	CVW-2	CVA 61	A-7B	WestPac/Vietnam
16 Apr 1971	06 Nov 1971	CVW-5	CVA 41	A-7B	WestPac/Vietnam
10 Apr 1972	03 Mar 1973	CVW-5	CVA 41	A-7B	WestPac/Vietnam
11 Sep 1973	05 Oct 1973	CVW-5	CVA 41	A-7A	WestPac*
26 Nov 1973	22 Dec 1973	CVW-5	CVA 41	A-7A	WestPac
29 Jan 1974	06 Mar 1974	CVW-5	CVA 41	A-7A	WestPac
18 Oct 1974	20 Dec 1974	CVW-5	CVA 41	A-7A	WestPac
13 Jan 1975	18 Feb 1975	CVW-5	CVA 41	A-7A	WestPac
31 Mar 1975	29 May 1975	CVW-5	CVA 41	A-7A	WestPac
04 Oct 1975	19 Dec 1975	CVW-5	CV 41	A-7A	WestPac/IO
13 Mar 1976	26 Apr 1976	CVW-5	CV 41	A-7A	WestPac
19 May 1976	22 Jun 1976	CVW-5	CV 41	A-7A	WestPac
09 Jul 1976	04 Aug 1976	CVW-5	CV 41	A-7A	WestPac
01 Nov 1976	17 Dec 1976	CVW-5	CV 41	A-7A	WestPac
11 Jan 1977	01 Mar 1977	CVW-5	CV 41	A-7A	WestPac
19 Apr 1977	02 Sep 1977	CVW-5	CV 41	A-7E	WestPac†



**Major Overseas Deployments—Continued**

<i>Date of Departure</i>	<i>Date of Return</i>	<i>Air Wing</i>	<i>Carrier</i>	<i>Type of Aircraft</i>	<i>Area of Operation</i>
27 Sep 1977	21 Dec 1977	CVW-5	CV 41	A-7E	WestPac/IO
11 Apr 1978	23 May 1978	CVW-5	CV 41	A-7E	WestPac
09 Nov 1978	23 Dec 1978	CVW-5	CV 41	A-7E	WestPac
11 Jan 1979	20 Feb 1979	CVW-5	CV 41	A-7E	WestPac
07 Apr 1979	18 Jun 1979	CVW-5	CV 41	A-7E	IO
20 Aug 1979	14 Sep 1979	CVW-5	CV 41	A-7E	WestPac
30 Sep 1979	20 Feb 1980	CVW-5	CV 41	A-7E	IO
14 Jul 1980	26 Nov 1980	CVW-5	CV 41	A-7E	WestPac/IO
23 Feb 1981	05 Jun 1981	CVW-5	CV 41	A-7E	WestPac/IO
26 Jun 1981	16 Jul 1981	CVW-5	CV 41	A-7E	WestPac
03 Sep 1981	06 Oct 1981	CVW-5	CV 41	A-7E	WestPac
26 Apr 1982	18 Jun 1982	CVW-5	CV 41	A-7E	WestPac
14 Sep 1982	11 Dec 1982	CVW-5	CV 41	A-7E	NorPac/WestPac
02 Jun 1983	13 Aug 1983	CVW-5	CV 41	A-7E	WestPac
25 Oct 1983	11 Dec 1983	CVW-5	CV 41	A-7E	WestPac
28 Dec 1983	23 May 1984	CVW-5	CV 41	A-7E	IO
15 Oct 1984	12 Dec 1984	CVW-5	CV 41	A-7E	WestPac
01 Feb 1985	14 Oct 1985	CVW-5	CV 41	A-7E	IO/WestPac
15 Nov 1985	12 Dec 1985	CVW-5	CV 41	A-7E	WestPac
17 Jan 1986	30 Mar 1986	CVW-5	CV 41	A-7E	WestPac

\* The squadron and *Midway* (CVA 41) arrived at their new home port, Naval Station Yokosuka, Japan. Since the squadron was permanently forward deployed all future deployments for the squadron will cover only those operations outside the home waters of Japan. The squadron returned to CONUS in May 1986, ending its overseas basing assignment.

† The squadron was shorebased at NAS Cubi Point during the latter part of April to August 1977 undergoing transitional training in the A-7E.

**Air Wing Assignments**

<i>Air Wing</i>	<i>Tail Code</i>	<i>Assignment Date</i>
CVG-5/CVW-5*	S/NF†	04 Jun 1956
CVW-9	NG	01 Jul 1966
COMFAIRALAMEDA		Oct 1968
CVW-2	NE	09 Jun 1969
CVW-5	NF	01 Jun 1970

\* Carrier Air Groups were redesignated Carrier Air Wings on 20 December 1963, hence, CVG-5 became CVW-5.

† CVG-5's tail code was changed from S to NF in 1957. The effective date was most likely the beginning of FY 58 (1 July 1957).

**Unit Awards Received**

<i>Unit Award</i>	<i>Inclusive Dates Covering Unit Award</i>	
NAVE	01 Jul 1959	30 Jun 1960
	01 Jul 1977	31 Dec 1978
AFEM	26 Sep 1961	30 Sep 1961
	27 Sep 1961	01 Oct 1961
	10 Oct 1961	14 Oct 1961
	16 Oct 1961	17 Oct 1961
	02 Aug 1964	05 Aug 1964
	11 Aug 1964	22 Sep 1964
	07 Oct 1964	29 Oct 1964
	02 Nov 1964	06 Nov 1964

**Unit Awards Received—Continued**

<i>Unit Award</i>	<i>Inclusive Dates Covering Unit Award</i>	
	21 Nov 1964	28 Nov 1964
	10 Jan 1970	13 Jan 1970
	12 Apr 1970	13 Apr 1970
	29 Apr 1975	30 Apr 1975
HSM	29 Apr 1975	30 Apr 1975
MUC	27 Oct 1969	12 May 1970
	07 May 1971	28 Oct 1971
	01 Jan 1978	20 May 1979
	13 Nov 1979	08 Feb 1980
	27 Jul 1982	01 May 1984
NEM	15 Apr 1979	06 Jun 1979
	21 Nov 1979	07 Feb 1980
	19 Aug 1980	13 Nov 1980
	12 Mar 1981	19 May 1981
NUC	02 Aug 1964	05 Aug 1964
	18 Dec 1966	20 Jan 1967
	14 Jan 1968	26 Jun 1968
	29 Apr 1975	30 Apr 1975
	01 Jan 1978	30 Jun 1979
PUC	30 Apr 1972	09 Feb 1973
RVNGC	30 Mar 1972	15 Jul 1972
VNSM	05 Nov 1965	01 Dec 1965
	22 Dec 1965	14 Jan 1966
	22 Jan 1966	16 Feb 1966

**Unit Awards Received—Continued**

<i>Unit Award</i>	<i>Inclusive Dates Covering Unit Award</i>	
	06 Mar 1966	31 Mar 1966
	10 Apr 1966	21 Apr 1966
	17 Dec 1966	17 Jan 1967
	31 Jan 1967	03 Mar 1967
	20 Mar 1967	18 Apr 1967
	28 Apr 1967	26 May 1967
	04 Jun 1967	21 Jun 1967
	21 Feb 1968	17 Mar 1968
	26 Mar 1968	24 Apr 1968
	11 Jun 1972	07 Jul 1972
	16 Jul 1972	13 Aug 1972
	23 Aug 1972	10 Sep 1972
	23 Oct 1972	23 Nov 1972
	03 Dec 1972	22 Dec 1972
	31 Dec 1972	
	04 Jan 1973	24 Jan 1973
	30 Apr 1968	21 May 1968
	30 May 1968	27 Jun 1968
	07 Jan 1969	30 Jan 1969
	15 Feb 1969	16 Mar 1969

**Unit Awards Received—Continued**

<i>Unit Award</i>	<i>Inclusive Dates Covering Unit Award</i>	
	04 Apr 1969	17 Apr 1969
	16 Nov 1969	07 Dec 1969
	17 Dec 1969	12 Jan 1970
	29 Jan 1970	18 Feb 1970
	27 Feb 1970	30 Mar 1970
	16 Apr 1970	14 May 1970
	17 May 1971	09 Jun 1971
	29 Jun 1971	20 Jul 1971
	31 Jul 1971	17 Aug 1971
	26 Sep 1971	11 Oct 1971
	01 May 1972	01 Jun 1972
	11 Jun 1972	07 Jul 1972
	16 Jul 1972	13 Aug 1972
	23 Aug 1972	10 Sep 1972
	23 Oct 1972	23 Nov 1972
	03 Dec 1972	22 Dec 1972
	31 Dec 1972	
	04 Jan 1973	24 Jan 1973
	03 Feb 1973	09 Feb 1973



*A flight of squadron A-7 Corsair IIs, 1973.*

## SECOND VA-64

### Lineage

Established as Attack Squadron SIXTY FOUR (VA-64) on 1 July 1961.

Disestablished on 7 November 1969. The second squadron to be assigned the VA-64 designation.

### Squadron Insignia and Nickname

The squadron's insignia was approved by CNO on 26 December 1961. Colors for the insignia were: a



*The Black Lancers' insignia.*

white background outlined in black; the knight's helmet was black with white markings and red plumage; and the scrolls had a white background, outlined in black, with black lettering.

Nickname: Black Lancers, circa 1961–1969.

### Chronology of Significant Events

**17 Feb–17 Jun 1962:** VA-64 Det 48, formed to provide an air defense capability for Carrier Anti-Submarine Air Groups, deployed aboard *Wasp* (CVS 18) for a North Atlantic cruise. The detachment's designation was changed to VA-64 Det 18B in April 1962. Lieutenant Commander E. D. Herbert was officer-in-charge of the detachment during the cruise.

**Oct–18 Nov 1962:** The squadron was embarked in *Independence* (CVA 62) operating in the Caribbean Sea in support of the Cuban quarantine.

**18 Nov–5 Dec 1962:** On 18 November, in an unusual at-sea evolution, VA-64 switched places with VA-34 and embarked in *Enterprise* (CVAN 65). The complements of both squadrons were lifted between carriers by helicopters. Following the transfer the squadron continued to operate in the Caribbean as part of the Cuban quarantine.

**Mar 1964:** The squadron conducted operations in the vicinity of Cyprus during a conflict between Turkish and Greek Cypriots.

**31 Jul–3 Oct 1964:** The squadron participated in operation Sea Orbit, the first circumnavigation of the world by a nuclear task force. The sixty-five day voyage was accomplished without logistic replenishment. The squadron participated in numerous air power demonstrations during the voyage.

**8 Jun 1967:** VA-64's aircraft were part of an Air Wing 6 strike group that was launched to defend *Liberty* (AGTR 5) when she came under attack by the Israelis. When word was received that the attack had been a mistake on the part of the Israelis the aircraft were recalled.

**Nov 1968:** The squadron provided an A-4C, two pilots and seven enlisted personnel to augment the VSF-1 detachment aboard *Wasp*. The detachment provided the ship with a day time air defense capability.

### Home Port Assignments

Location	Assignment Date
NAS Oceana	01 Jul 1961
NAS Cecil Field	15 Feb 1965

### Commanding Officers

	Date Assumed Command
LCDR Paul A. Anderson	01 Jul 1961
CDR R. A. Uhwat	31 May 1962
CDR F. E. Babineau	20 Jun 1963
CDR David E. Scherrer	28 Jun 1964
CDR Max D. Barr	12 Jun 1965
CDR James E. Kneale	07 Jun 1966
CDR Keith C. Spayde, Jr.	12 Jun 1967
CDR Jerald W. Bucklin	29 May 1968
CDR Stuart T. Meredith	1969

### Aircraft Assignment

Type of Aircraft	Date Type First Received
A4D-2N/A-4C*	18 Jul 1961
A4D-2†	28 Dec 1961

\* The A4D-2N was redesignated A-4C in 1962.

† The A4D-2 was used by VA-64 Detachment 48.

**Major Overseas Deployments—Continued**

<i>Date of Departure</i>	<i>Date of Return</i>	<i>Air Wing</i>	<i>Carrier</i>	<i>Type of Aircraft</i>	<i>Area of Operation</i>
06 Feb 1963	04 Sep 1963	CVG-6	CVAN 65	A-4C	Med
08 Feb 1964	03 Oct 1964	CVW-6	CVAN 65	A-4C	Med/World Cruise
30 Nov 1965	10 Jul 1966	CVW-6	CVA 66	A-4C	Med
10 Jan 1967	20 Sep 1967	CVW-6	CVA 66	A-4C	Med
30 Apr 1968	27 Jan 1969	CVW-7	CVA 62	A-4C	Med
03 Sep 1969	09 Oct 1969	CVW-7	CVA 62	A-4C	NorLant

**Air Wing Assignments**

<i>Air Wing</i>	<i>Tail Code</i>	<i>Assignment Date</i>
CVG-6	AF	01 Jul 1961
CVG-1	AB	08 Feb 1962
COMFAIRNORFOLK		31 Jul 1962
CVG-7	AG	01 Oct 1962
CVG-6/CVW-6*	AF/AE*	18 Nov 1962
CVW-7	AG	16 Oct 1967

\* CVG-6 was redesignated CVW-6 when all Carrier Air Group (CVG) designations were changed to Carrier Air Wings (CVW) on 20 December 1963. Sometime in the latter part of 1962 CVG-6's tail code was changed from AF to AE.

**Unit Awards Received**

<i>Unit Award</i>	<i>Inclusive Dates Covering Unit Award</i>	
AFEM	24 Oct 1962	20 Nov 1962



*A squadron A-4C Skyhawk is prepared for launch from America (CVA 66) in 1965.*

## SECOND VA-65

### Lineage

Established as Torpedo Squadron SEVENTY FOUR (VT-74) on 1 May 1945.

Redesignated Attack Squadron TWO B (VA-2B) on 15 November 1946.

Redesignated Attack Squadron TWENTY FIVE (VA-25) on 1 September 1948.

Redesignated Attack Squadron SIXTY FIVE (VA-65) on 1 July 1959.

Disestablished on 31 March 1993. The second squadron to be assigned the VA-65 designation.

### Squadron Insignia and Nickname

The squadron's first insignia was approved by CNO



*The beast was the squadron's first insignia. It was designed by the squadron when they were flying the SB2C, nicknamed the "Beast."*

on 9 August 1945. During the time when the squadron's insignia was approved, VT-74 was flying the SB2C which was nicknamed the Beast. Consequently, the squadron's insignia took on the shape of a beast riding a torpedo. There is no record of the colors used for this insignia.



*Following the squadron's redesignation as an attack squadron, the knight chess piece insignia was approved.*



*The squadron's last insignia, the prowling tiger, was in use for over 40 years and was a well-known insignia in naval aviation.*

After VT-74 was redesignated VA-2B, it continued to use the old insignia until 17 April 1947 when CNO approved a new insignia for the squadron. The insignia adopted by VA-2B reflected the squadron's new attack mission. The horsehead chess piece was designed to relate the squadron's power to that of a medieval knight and the fleur-de-lis represented integrity. Colors for the insignia were: a yellow background; red scroll with yellow lettering, black banner with a black and white pole; white knight with a yellow collar; a white lightning bolt; and the Fleur-de-lis was red with a black band.

The Knight insignia continued as the official insignia for the squadron following its redesignation to VA-25 on 1 September 1948. A new insignia for VA-25 was approved by CNO on 4 April 1950. The new insignia was a front view of a tiger on the prowl. Colors were: yellow background; brown tiger with green eyes, and white teeth, whiskers and claws; and a red tongue and mouth. When VA-25 was redesignated VA-65 in 1959 the tiger insignia was retained and remained VA-65's insignia until its disestablishment.

Nickname: Tigers, 1950–1993.

### Chronology of Significant Events

**7 Nov 1945:** Squadron embarked in *Midway* (CVB 41) for her shakedown cruise. The squadron had originally been established for the purpose of being part of the *Midway* Air Group.

**Jul-Aug 1948:** The squadron participated in operation CAMID III, close air support for amphibious landings. During this operation the squadron became the first VA unit in the Atlantic Fleet to fire Tiny Tim rockets.

**1–20 Jun 1961:** Following a four-hour notice for an emergency deployment, VA-65 deployed to the Caribbean Sea aboard *Intrepid* (CVA 11) due to unsettled conditions in the Dominican Republic following the assassination of General Trujillo.

**3 Aug–11 Oct 1962:** VA-65 was aboard for the maiden cruise of the world's first nuclear powered aircraft carrier, *Enterprise* (CVAN 65), during her deployment to the Mediterranean Sea.

**19 Oct–6 Dec 1962:** VA-65 was back at sea aboard *Enterprise* one week after returning from a Med cruise and headed for the Caribbean Sea due to the Cuban missile crisis. The squadron participated in the naval quarantine of Cuba.

**31 Jul–3 Oct 1964:** The squadron participated in Operation Sea Orbit as part of CVW-6 aboard *Enterprise*. This operation was an around-the-world voyage of a task force composed of all nuclear powered ships. The sixty-five day cruise was accomplished without logistic support, which demonstrated the capability of these ships to steam to any area in the world and project power without support.

**15 Jun 1966:** VA-65 conducted its first combat sortie.

**1 Jul 1966:** VA-65's aircraft joined other CVW-15 aircraft in attacking and sinking three North Vietnamese patrol vessels that were approaching *Coontz* (DLG 9) at high speed.

**25–31 Oct 1966:** Due to the inclement weather, the squadron's all-weather A-6As were used to the maximum. During this period VA-65 flew 37 percent of all Yankee Team sorties in North Vietnam.

**29 Jul 1967:** VA-65 personnel were among those killed or injured when a flight deck explosion and fire occurred on *Forrestal* (CVA 59) during operations on Yankee Station.

**Jul–Dec 1967:** Due to the fire on the *Forrestal* and her departure from combat duty on Yankee Station, VA-65 sent a detachment (Det-64) to the *Constellation* (CVA 64) to augment VA-196 for the remainder of the ship's 1967 combat tour in Vietnam.

**May–Jun 1969:** *Kitty Hawk* (CVA 63), with VA-65 aboard, relieved *Enterprise* in the Sea of Japan. *Enterprise* had been ordered to operate in the area as a result of the shoot down in April of an unarmed Navy EC-121 reconnaissance aircraft by North Korean MiGs. VA-65 conducted operations in the area during this two month period.

**9 Sep–5 Oct 1970:** VA-65 operated from *Independence* (CVA 62) on Bravo Station off the coast of Israel as a result of the crisis in Jordan and the hijacking of three commercial airliners.

**7 Oct–3 Nov & 9–21 Nov 1973:** After the outbreak of the Yom Kippur War (Arab-Israeli War of 1973), VA-65 operated from *Independence* in an area southwest of Crete and provided tanker support to fighter aircraft escorting Air Force One on Secretary of State Kissinger's mission to Israel as well as tanker support for A-4 Skyhawks being ferried to Israel from the United States.

**4–22 Aug 1974:** *Independence*, with VA-65 embarked, operated between Crete and Cyprus in response to the crisis in Cyprus and the death of the American Ambassador to Cyprus at the hands of anti-American demonstrators.

**12 Mar 1975:** During exercises in the Caribbean Sea, VA-65 conducted cross deck operations with HMS *Ark Royal*.

**Nov 1975:** During the NATO exercise Ocean Safari in the North Atlantic, the squadron once again conducted cross deck operations with HMS *Ark Royal*.

**15 Apr 1980:** VA-65 deployed aboard *Dwight D. Eisenhower* (CVN 69) to the Indian Ocean after Iranians took the American Embassy personnel hostage.

**22 Dec 1980:** VA-65 returned from its deployment that included only one port visit of five days in duration and a total of 246 days at sea.

**24 Jun 1982:** VA-65 provided support during the evacuation of American and foreign civilians from Beirut, Lebanon.

**7 Mar 1985:** VA-65 and *Dwight D. Eisenhower* cut short a port visit to Palma, Spain and departed on a high speed transit to the Eastern Mediterranean due to the increased tension in Lebanon. The squadron operated in the vicinity of Lebanon until early April.

**1 Sep 1986:** VA-65 was assigned to CVW-13 and *Coral Sea* (CV 43) as part of the *Coral Sea* Concept whereby two A-6 Intruder squadrons would be part of the air wing and share a common aircraft maintenance department. The concept was intended to reduce the number of personnel needed to support the squadrons.

**29 Sep 1987:** VA-65 deployed to the Mediterranean Sea aboard *Coral Sea* as the first Night Vision Goggle (NVG) capable A-6 squadron.

**Aug–Sep 1989:** *Coral Sea* (CV 43), with VA-65 embarked, was ordered to operate off the coast of Lebanon following terrorist claims to have killed an American hostage, Lieutenant Colonel William R. Higgins, and the capture of Sheik Obeid from Lebanon by Israeli forces. The unstable situation in Lebanon ultimately led to the evacuation of the American Embassy. Squadron aircraft flew missions in support of the evacuation.

**Jan–Feb 1990:** The squadron was embarked in *Abraham Lincoln* (CVN 72) for her shakedown cruise.

**Jan–Feb 1991:** The squadron participated in Operation Desert Storm, the liberation of Kuwait from Iraqi forces. Squadron aircraft struck targets in Iraq, Iraqi forces in Kuwait, and Iraqi naval units. The squadron claimed the destruction (sinking) of 22 Iraqi naval vessels during the conflict.

**Apr–May 1991:** VA-65 participated in Operation Provide Comfort, flying close air support sorties over Northern Iraq in support of the 24th Marine Expeditionary Unit's mission to aid the Kurdish refugees in Iraq.

**26 Mar 1993:** The squadron held a disestablishment ceremony at NAS Oceana, it was officially disestablished on 31 March 1993.



A rare photo of a squadron SB2C in post-World War II markings. What is even more interesting is the fact that a torpedo squadron was assigned an aircraft designed primarily as a bomber.

### Home Port Assignments

Location	Assignment Date
NAAF Otis Field, Camp Edwards	01 May 1945
NAS Norfolk	Oct 1945
NAAS Charlestown	Feb 1946
NAAS Oceana	Jun 1946
CGAS Elizabeth City	20 Nov 1950
NAAS Oceana/NAS Oceana*	20 Sep 1951

\* NAAS Oceana was redesignated NAS Oceana on 1 April 1952.

### Commanding Officers

	Date Assumed Command
LCDR Howard U. Bush	01 May 1945
LCDR John J. Hilton	05 Oct 1945
LCDR J. C. Micheel	16 Nov 1946
CDR K. W. Caffey	09 Apr 1947
CDR Arthur B. Sweet	11 Jun 1948
LCDR William W. Jones (Acting)	07 Sep 1949
CDR Arthur M. Ershler	10 Nov 1949
CDR Ray C. Tylutki	31 May 1951
LCDR Jean C. Mills	27 Oct 1952
CDR Thomas H. Stetson	Sep 1953
CDR Roy P. Gee	Feb 1955
CDR William G. Weber	Apr 1956
LCDR John R. O'Neil, Jr.	25 Nov 1957
CDR Leland B. Cornell	17 Dec 1957
CDR William D. McNair	11 Sep 1959
CDR Maurice O. Rishel	16 Nov 1960
CDR W. F. Offtermatt	23 Oct 1961
CDR Harry W. Swinburne, Jr.	19 Oct 1962
CDR William J. Whitney	04 Jul 1963
CDR Norman E. Larsen	01 May 1964
CDR William N. Small	30 Nov 1964
CDR Robert C. Mandeville	30 Jun 1966
CDR Frank Cramblet	Jun 1967
CDR St. Clair Smith	14 Jun 1968
CDR Michael F. Andrassy	16 Jun 1969
CDR Peter B. Easton	19 Jun 1970
CDR William P. Lyons	10 Jun 1971
CDR Thomas E. Shanahan	23 Jun 1972
CDR Paul F. Hollandsworth	29 Jun 1973
CDR Charles D. Hawkins, Jr.	25 Jun 1974
CDR George H. Strohsahl, Jr.	27 Jun 1975
CDR Donald L. Hahn	14 Sep 1976
CDR William R. Needham	16 Dec 1977
CDR Herbert A. Browne, Jr.	23 Mar 1979
CDR Joseph W. Prueher	20 Jun 1980
CDR Dickey P. Davis	25 Sep 1981
CDR Robert E. Houser	07 Dec 1982
CDR William J. Fallon	03 May 1984
CDR Robert L. Leitzel	06 Sep 1985
CDR Stephen H. Baker	13 Feb 1987
CDR Michael C. Vogt	12 Aug 1988

### Commanding Officers—Continued

	Date Assumed Command
CDR Ralph H. Coon	23 Feb 1990
CDR Thomas J. Ross	12 Aug 1991
CDR James K. Stark, Jr.	04 Sep 1992



Squadron AD-6 Skyraiders are directed to the catapult aboard Intrepid (CVA 11) in 1961.

### Aircraft Assignment

Type of Aircraft	Date Type First Received
SBW-4E	May 1945
SB2C-4E	Jul 1945
SB2C-5	Feb 1946
TBM-3E	Feb 1946
SBW-5	1946
SNJ-4	Jul 1947
AD-1	Jul 1947
AD-4	01 Dec 1949
AD-6/A-1H*	Oct 1953
A-6A	Mar 1965
A-6B	Dec 1968
KA-6D	1971†
A-6E	03 May 1972

\* AD-6 designation changed in 1962 to A-1H.

† The KA-6D was received sometime between April and June 1971.



A squadron A-6A Intruder in flight with a load of bombs, 1970.

**Major Overseas Deployments**

<i>Date of Departure</i>	<i>Date of Return</i>	<i>Air Wing</i>	<i>Carrier</i>	<i>Type of Aircraft</i>	<i>Area of Operation</i>
29 Oct 1947	11 Mar 1948	CVBG-1	CVB 41	AD-1	Med
03 May 1949	25 Sep 1949	CVG-2	CVB 43	AD-1	Med
10 Jan 1951	18 May 1951	CVG-6	CVB 42	AD-4	Med
09 Jan 1952	05 May 1952	CVG-6	CVB 41	AD-4	Med
26 Aug 1952	08 Oct 1952	CVG-6	CVB 41	AD-4	NorLant
01 Dec 1952	19 May 1953	CVG-6	CVA 41	AD-4	Med
04 Jan 1954	04 Aug 1954	CVG-6	CVA 41	AD-6	Med
09 Oct 1955	30 Apr 1956	CVG-6	CVA 39	AD-6	Med
03 Sep 1957	21 Oct 1957	CVG-6	CVA 11	AD-6	NorLant
12 Feb 1959	30 Aug 1959	CVG-6	CVA 11	AD-6	Med
04 Aug 1960	17 Feb 1961	CVG-6	CVA 11	AD-6	Med
03 Aug 1961	01 Mar 1962	CVG-6	CVA 11	AD-6	Med
03 Aug 1962	11 Oct 1962	CVG-6	CVAN 65	A-1H	Med
19 Oct 1962	06 Dec 1962	CVG-6	CVAN 65	A-1H	Carib
06 Feb 1963	04 Sep 1963	CVG-6	CVAN 65	A-1H	Med
08 Feb 1964	03 Oct 1964	CVW-6	CVAN 65	A-1H	Med/World Cruise
12 May 1966	03 Dec 1966	CVW-15	CVA 64	A-6A	WestPac/Vietnam
06 Jun 1967	15 Sep 1967	CVW-17	CVA 59	A-6A	WestPac/Vietnam
30 Dec 1968	04 Sep 1969	CVW-11	CVA 63	A-6A/B	WestPac/Vietnam
23 Jun 1970	31 Jan 1971	CVW-7	CVA 62	A-6A	Med
16 Sep 1971	16 Mar 1972	CVW-7	CVA 62	A-6A/KA-6D	NorLant/Med
21 Jun 1973	19 Jan 1974	CVW-7	CV 62	A-6E/KA-6D	Med
19 Jul 1974	21 Jan 1975	CVW-7	CV 62	A-6E/KA-6D	Med
15 Oct 1975	05 May 1976	CVW-7	CV 62	A-6E/KA-6D	NorLant/Med
31 Mar 1977	21 Oct 1977	CVW-7	CV 62	A-6E/KA-6D	Med
16 Jan 1979	13 Jul 1979	CVW-7	CVN 69	A-6E/KA-6D	Med
15 Apr 1980	22 Dec 1980	CVW-7	CVN 69	A-6E/KA-6D	IO
20 Aug 1981	07 Oct 1981	CVW-7	CVN 69	A-6E/KA-6D	NorLant
05 Jan 1982	13 Jul 1982	CVW-7	CVN 69	A-6E/KA-6D	Med
27 Apr 1983	02 Dec 1983	CVW-7	CVN 69	A-6E/KA-6D	Med
08 May 1984	20 Jun 1984	CVW-7	CVN 69	A-6E/KA-6D	Carib/NorLant
10 Oct 1984	08 May 1985	CVW-7	CVN 69	A-6E/KA-6D	Med
08 Jul 1985	22 Aug 1985	CVW-7	CVN 69	A-6E/KA-6D	Carib
29 Sep 1987	28 Mar 1988	CVW-13	CV 43	A-6E	Med
31 May 1989	30 Sep 1989	CVW-13	CV 43	A-6E	Med
28 Dec 1990	28 Jun 1991	CVW-8	CVN 71	A-6E	Med/Red Sea/ Persian Gulf



*A KA-6D from VA-65 refuels an RA-5C Vigilante, 1971.*



**Air Wing Assignments**

<i>Air Wing</i>	<i>Tail Code</i>	<i>Assignment Date</i>
CVG-74		01 May 1945
CVBG-1*	M	15 Nov 1946
CVG-2†	M	01 Sep 1948
CVG-6	C	Aug 1950
CVG-6	AF‡	
CVG-6/CVW-6§	AE§	
RCVW-4	AD	01 Jan 1965
COMFAIRNORFOLK		05 Jun 1965
CVW-15	NL	20 Feb 1966
COMFAIRNORFOLK		03 Dec 1966
CVW-17	AA	22 Dec 1966
COMFAIRNORFOLK		15 Sep 1967
CVW-11	NH	1968
COMFAIRNORFOLK		Sep 1969
CVW-7	AG	Feb 1970
CVW-13	AK	01 Sep 1986
CVW-8	AJ	30 Oct 1989

\* CVG-74 was redesignated CVBG-1 on 15 November 1946.  
 † CVBG-1 was redesignated CVG-2 on 1 September 1948.  
 ‡ CVG-6's tail code was changed from C to AF in the latter part of 1957. The effective date was most likely the beginning of FY 58 (1 July 1957).  
 § CVG-6's tailcode was changed from AF to AE sometime in the latter part of 1962. Carrier Air Groups (CVG) were redesignated Carrier Air Wings (CVW) on 20 December 1963, hence, CVG-6 became CVW-6.

**Unit Awards**

<i>Unit Award</i>	<i>Inclusive Dates Covering Unit Award</i>	
NAVE	1948	1948*
	01 Jul 1951	30 Jun 1952
	01 Jul 1959	30 Jun 1960
	1967	1967†
	01 Oct 1977	30 Sep 1978
	01 Oct 1979	30 Sep 1980
	01 Jan 1984	31 Dec 1984

**Unit Awards—Continued**

<i>Unit Award</i>	<i>Inclusive Dates Covering Unit Award</i>	
	01 Jan 1991	31 Dec 1991
AFEM	24 Oct 1962	21 Nov 1962
	15 May 1969	
	25 May 1969	27 May 1969
	05 Jun 1969	
	07 Jun 1969	15 Jun 1969
	25 Jun 1969	
	06 Jun 1983	14 Jun 1983
	27 Jul 1983	30 Aug 1983
	01 Sep 1983	19 Oct 1983
	27 Oct 1983	20 Nov 1983
MUC	09 Sep 1970	05 Oct 1970
	30 Mar 1988	30 Sep 1989
NEM	29 Apr 1980	16 Jul 1980
	22 Jul 1980	08 Dec 1980
	25 May 1983	27 May 1983
NUC	15 Jan 1969	27 Aug 1969
	29 Apr 1980	10 Dec 1980
	21 Jul 1983	20 Nov 1983
	27 Oct 1984	24 Apr 1985
	17 Jan 1991	07 Feb 1991
VNSM	14 Jun 1966	13 Jul 1966
	27 Jul 1966	31 Aug 1966
	08 Sep 1966	01 Oct 1966
	19 Oct 1966	09 Nov 1966
	23 Jul 1967	30 Jul 1967
	12 Aug 1967	
	27 Jan 1969	01 Mar 1969
	12 Mar 1969	05 Apr 1969
	17 Apr 1969	10 May 1969
	28 Jun 1969	15 Jul 1969
	27 Jul 1969	16 Aug 1969
KLM	7 Jan 1991	28 Feb 1991
SASM	14 Jan 1991	20 Apr 1991
JMUC	05 Apr 1991	16 Jul 1991

\* The award covers the competitive year 1948.  
 † The award covers the competitive year 1967.



A British Victor tanker refuels a squadron KA-6D Intruder and an F-4 Phantom II. Note the refueling line and basket being trailed by the squadron's KA-6D.

## SECOND VA-66

### Lineage

Reserve Fighter Squadron SIX SEVENTY ONE (VF-671) was called to active duty on 1 February 1951.

Redesignated Fighter Squadron EIGHTY ONE (VF-81) on 4 February 1953.

Redesignated Attack Squadron SIXTY SIX (VA-66) on 1 July 1955.

Disestablished on 1 October 1986. The second squadron to be assigned the VA-66 designation. A VA-66 detachment continued in existence until 31 March 1987.

### Squadron Insignia and Nickname

The squadron's first insignia was approved by CNO on 28 September 1953. No description or photograph of it is available in the squadron records.



*The official records do not contain a copy of the squadron's first insignia. However, the second insignia, a rooster toting a machine gun, is a well-known design in naval aviation.*

The squadron's second insignia was approved by CNO on 25 January 1955. This insignia, a rooster toting a machine gun, became a well known design during the next three decades. Colors for the insignia were: a black background outlined in red; the rooster was red with black markings; his feet and beak were yellow, as well as the life vest; the face, hands and neck were white with black markings

and he had black eyes; his claws and spurs were gray; the machine gun was gray with black markings and white smoke trailing from the barrel; and the banner was white, outlined in black and with black letters. The insignia continued in use following the squadron's redesignation on 1 July 1955.

Nickname: Waldomen, circa 1950s-early 1960s.

Waldos, circa early 1960s-1987.

### Chronology of Significant Events

**Jan-Feb 1953:** VF-81, with its F9F-5s, participated in operational tests aboard the Navy's first angled deck carrier, *Antietam* (CVA 36).

**Apr 1954:** VF-81 became the first operational fleet squadron to receive and operate the F7U Cutlass.

**27 May 1959:** During the squadron's deployment to the Mediterranean Sea, the commanding officer, Commander McNeil, was killed in an aircraft accident during a practice Carrier Controlled Approach.

**14 Aug 1962:** The squadron participated in cross deck operations aboard the British carrier HMS *Hermes* (R-12).

**Oct-Dec 1962:** While embarked in *Enterprise* (CVAN 65), the squadron participated in the Cuban Blockade.

**31 Jul-3 Oct 1964:** *Enterprise* (CVAN 65), with VA-66 embarked, participated in operation Sea Orbit, the first circumnavigation of the world by a nuclear task force. The sixty-five day voyage was accomplished without replenishment. The squadron participated in numerous air power demonstrations during the voyage.

**8 Jun 1967:** VA-66's aircraft were part of an Air Wing 6 strike group that was launched to defend *Liberty* (AGTR 5) when she came under attack by the Israelis during the 1967 Israeli-Arab War. When word was received that the attack had been a mistake on the part of the Israelis, the aircraft were recalled.

**Jun 1970:** VA-66, embarked in *Forrestal* (CVA 59), operated in the Eastern Mediterranean after Americans were taken hostage by the Popular Front for the Liberation of Palestine in Amman, Jordan.

**Oct-Nov 1973:** Embarked on *Independence* (CV 62), the squadron operated south of Crete during the Arab-Israeli War.

**Aug 1974:** *Independence* (CV 62) relieved *America* (CV 66) off Cyprus following a coup on the island. During the crisis the American Ambassador was killed and anti-American demonstrations took place which led to the evacuation of U.S. citizens to American vessels.

**15 Apr 1980:** *Dwight D. Eisenhower* (CVN 69) deployed to the Indian Ocean as part of the continuing response to the hostage crisis in Iran.

**22 Dec 1980:** The squadron returned from its deployment to the Indian Ocean after spending a total of 246 days at sea. With only one port visit, the longest at sea period was for 153 days.

**Jun 1982:** After the Israeli invasion of Lebanon on 6 June, VA-66 operated in the Eastern Mediterranean. During the latter part of June the American carrier forces in the Mediterranean included *Eisenhower* (CVN 65), *Independence* (CV 62), *Forrestal* (CV 59), and *John F. Kennedy* (CV 67).

**24 Jun 1982:** VA-66 provided air support during the evacuation of Americans from Beirut, Lebanon, prior to the siege of Beirut by the Israelis.

**25 Oct 1983:** Due to the bombing of the Marine Corps barracks in Beirut, *Eisenhower* (CVN 65) terminated its visit to Naples and departed for the eastern Mediterranean. The squadron operated in the vicinity of Lebanon until the latter part of November.

**7 Mar 1985:** *Eisenhower* (CVN 65) cut short a visit to Palma, Spain, and made a high speed transit to the Eastern Mediterranean due to the increased tension in Lebanon.

**1 Oct 1986:** The Waldos of VA-66 were officially disestablished but continued to operate as a detachment. The detachment continued to operate because its pri-

mary mission during the deployment was to provide Harm missile support for the air wing and carrier.

**30 Jan 1987:** *Kennedy* (CV 67) cancelled its port visit to Malaga, Spain, and made a high speed transit to the eastern Mediterranean due to the increased tension over the hostages held in Lebanon.

**31 Mar 1987:** VA-66 Detachment was disestablished.



A squadron F4U-4 Corsair during its deployment to the Med aboard *Tarawa* (CV 40) in 1952 (Courtesy Duane Kasulka Collection).

**Home Port Assignments**

<i>Location</i>	<i>Assignment Date</i>
NAS Atlanta	01 Feb 1951
NAS Jacksonville	05 Apr 1951
NAS Quonset	28 Sep 1951
NAS Oceana	11 Jun 1952
NAS Cecil Field	15 Mar 1965

**Commanding Officers**

	<i>Date Assumed Command</i>
CDR H. K. Pryce	01 Feb 1951
CDR J. M. James	30 Sep 1952
CDR Herman J. Harders	Oct 1953
CDR W. Manby, Jr.	Jun 1955
CDR Uncas L. Fretwell	Aug 1955
CDR Robert J. Selmer	Sep 1956
CDR W. J. McNeil, Jr.	16 Dec 1957
CDR D. V. Marshall, Jr. (acting)	27 May 1959

**Commanding Officers—Continued**

	<i>Date Assumed Command</i>
CDR E. C. Griffin	28 Jun 1959
CDR R. I. Kasten	06 Jul 1960
CDR J. S. Herman	26 May 1961
CDR J. M. Tierney	04 May 1962
CDR R. E. Spruit	31 May 1963
CDR D. L. Hancock	11 May 1964
CDR W. B. Bagwell	23 Apr 1965
CDR L. Wayne Smith	06 Jun 1966
CDR E. M. Crow	06 Jun 1967
CDR W. E. Ramsey	May 1968
CDR A. J. Karpaitis	Feb 1969
CDR B. A. White	Jan 1970
CDR W. C. Nix	Aug 1970
CDR J. J. Fleming	Jun 1971
CDR L. E. Barringer	Jun 1972
CDR R. C. Macke	13 Aug 1973
CDR D. P. March	Nov 1974
CDR Robert T. Davis	05 Mar 1976
CDR Stuart J. Fitrell	03 Jun 1977
CDR James E. Gill	Jun 1978
CDR Frank H. Gerwe, Jr.	02 Aug 1979
CDR Kent W. Ewing	11 Oct 1980
CDR Richard D. Lichtermann II	05 Feb 1982
CDR Robert W. Nordman	13 Apr 1983
CDR Robert J. Kelsey	03 Oct 1984
CDR Richard L. Marquis	15 Apr 1986

**Aircraft Assignment**

<i>Type of Aircraft</i>	<i>Date Type First Received</i>
F4U-4	Feb 1951
F8F-2	13 Jun 1952
F9F-5	05 Dec 1952
F7U-3	Apr 1954
F9F-8B	Aug 1956
A4D-1	Mar 1958
A4D-2	Jun 1958
A4D-2N/A-4C*	Mar 1961
A-7E	Oct 1970

\* The A4D-2N designation was changed to A-4C in 1962.

**Major Overseas Deployments**

<i>Date of Departure</i>	<i>Date of Return</i>	<i>Air Wing</i>	<i>Carrier</i>	<i>Type of Aircraft</i>	<i>Area of Operation</i>
28 Nov 1951	11 Jun 1952	CVG-8	CV 40	F4U-4	Med
26 Apr 1953	21 Oct 1953	CVG-8	CVA 43	F9F-5	Med
04 Nov 1955	02 Aug 1956	CVG-3	CVA 14	F7U-3	Med
03 Sep 1957	22 Oct 1957	CVG-6	CVA 11	F9F-8B	NorLant
13 Feb 1959	30 Aug 1959	CVG-6	CVA 11	A4D-2	Med
04 Aug 1960	17 Feb 1961	CVG-6	CVA 11	A4D-2	Med
03 Aug 1961	01 Mar 1962	CVG-6	CVA 11	A4D-2N	Med

**Major Overseas Deployments—Continued**

<i>Date of Departure</i>	<i>Date of Return</i>	<i>Air Wing</i>	<i>Carrier</i>	<i>Type of Aircraft</i>	<i>Area of Operation</i>
03 Aug 1962	11 Oct 1962	CVG-6	CVAN 65	A4D-2N	Med
06 Feb 1963	04 Sep 1963	CVG-6	CVAN 65	A-4C	Med
08 Feb 1964	03 Oct 1964	CVW-6	CVAN 65	A-4C	Med/World Cruise
30 Nov 1965	10 Jul 1966	CVW-6	CVA 66	A-4C	Med
10 Jan 1967	20 Sep 1967	CVW-6	CVA 66	A-4C	Med
04 Jun 1968	08 Feb 1969	CVW-10	CVS 11	A-4C	WestPac/Vietnam
02 Dec 1969	08 Jul 1970	CVW-17	CVA 59	A-4C	Med
16 Sep 1971	16 Mar 1972	CVW-7	CVA 62	A-7E	NorLant/Med
21 Jun 1973	19 Jan 1974	CVW-7	CV 62	A-7E	Med
19 Jul 1974	21 Jan 1975	CVW-7	CV 62	A-7E	Med
15 Oct 1975	05 May 1976	CVW-7	CV 62	A-7E	NorLant/Med
31 Mar 1977	21 Oct 1977	CVW-7	CV 62	A-7E	Med
16 Jan 1979	13 Jul 1979	CVW-7	CVN 69	A-7E	Med
15 Apr 1980	22 Dec 1980	CVW-7	CVN 69	A-7E	IO
20 Aug 1981	07 Oct 1981	CVW-7	CVN 69	A-7E	NorLant
05 Jan 1982	13 Jul 1982	CVW-7	CVN 69	A-7E	Med
27 Apr 1983	02 Dec 1983	CVW-7	CVN 69	A-7E	Med
08 May 1984	20 Jun 1984	CVW-7	CVN 69	A-7E	Carib/NorLant
10 Oct 1984	08 May 1985	CVW-7	CVN 69	A-7E	Med
08 Jul 1985	22 Aug 1985	CVW-7	CVN 69	A-7E	Carib
18 Aug 1986	02 Mar 1987	CVW-3	CV 67	A-7E	Med



A squadron F7U-3 Cutlass on the flight line, believed to be at NAS Port Lyautey, Morocco. The squadron was stationed at the air station during part of its 1953 Med cruise.

**Air Wing Assignments**

<i>Air Wing</i>	<i>Tail Code</i>	<i>Assignment Date</i>
CVG-8	E	09 Apr 1951
CVG-6	C	01 Jul 1955
CVG-3	K	Nov 1955
CVG-6/CVW-6*	C/AF/AE†	Aug 1956
CVW-7	AG	06 Oct 1967
CVW-10	AK	Jan 1968
CVW-17	AA	02 Jun 1969

**Air Wing Assignments—Continued**

<i>Air Wing</i>	<i>Tail Code</i>	<i>Assignment Date</i>
COMLATWING-1		09 Jul 1970
CVW-7	AG	1971
CVW-3		01 Oct 1986‡

\* CVG-6 was redesignated CVW-6 when all Carrier Air Group (CVG) designations were redesignated Carrier Air Wings (CVW) on 20 December 1963.

† CVG-6's tail code was changed from C to AF in 1957. The effective date was most likely the beginning of FY 58 (1 July 1957). Sometime in the latter part of 1962 CVG-6's tail code was changed from AF to AE.

‡ VA-66 deployed with CVW-3 in *John F. Kennedy* (CV 67) in August 1986. Administratively, it continued to be assigned to CVW-7 until its official disestablishment on 1 October 1986. After that date, the same organization continued to operate as a detachment assigned to CVW-3 until the deployment ended in March 1987.



A squadron A4D-2 Skyhawk in 1959.

**Unit Awards Received**

<i>Unit Award</i>	<i>Inclusive Dates Covering Unit Award</i>	
AFEM	24 Oct 1962	03 Dec 1962
	06 Jun 1983	14 Jun 1983
	27 Jul 1983	30 Aug 1983
	01 Sep 1983	19 Oct 1983
	27 Oct 1983	20 Nov 1983
NEM	19 Oct 1962	23 Oct 1962
	29 Apr 1980	16 Jul 1980
	22 Jul 1980	08 Dec 1980
	25 May 1983	27 May 1983
NUC	06 Jul 1968	16 Jan 1969

**Unit Awards Received—Continued**

<i>Unit Award</i>	<i>Inclusive Dates Covering Unit Award</i>	
	29 Apr 1980	10 Dec 1980
	21 Jul 1983	20 Nov 1983
RVNGC	01 Oct 1968	01 Nov 1968
SLOC	Oct 1978	Dec 1979
VNSM	11 Jul 1968	12 Jul 1968
	14 Jul 1968	15 Jul 1968
	23 Jul 1968	22 Aug 1968
	14 Oct 1968	14 Nov 1968
	03 Dec 1968	27 Dec 1968



Two squadron A-7E Corsair IIs show the difference between the old and new paint schemes in 1984. The gun-toting rooster insignia is on the tail of both aircraft.

## VA-72

### Lineage

Established as Bomber Fighter Squadron EIGHTEEN (VBF-18) on 25 January 1945.

Redesignated Fighter Squadron EIGHT A (VF-8A) on 15 November 1946.

Redesignated Fighter Squadron SEVENTY TWO (VF-72) on 28 July 1948.

Redesignated Attack Squadron SEVENTY TWO (VA-72) on 3 January 1956.

Disestablished on 30 June 1991. The first squadron to be assigned the VA-72 designation.

### Squadron Insignia and Nickname

The squadron's first insignia was approved by CNO on 9 April 1946. Colors for the bear-cat insignia were:



*The bearcat was the squadron's first insignia.*

white upper background and sky blue lower background outlined in black; black bear-cat with white markings and a red tongue; white cloud with sky blue markings; white and black carrier and the waves extending from the carrier were white, streaked with black; and a black bomb and gun with white markings.

On 5 December 1950 a new insignia was approved by CNO. Colors for the peregrine falcon were: a red outline with upper background white and the lower background blue; the falcon had a black head with gray feathers and black markings; the beak, eye and feet were yellow with black markings and the tongue was red.



*The hawk insignia was adopted by the squadron in 1950.*

Following the squadron's redesignation in 1956 it continued to use the falcon insignia but modified it to include a scroll with the word **ATAKRON 72**. The scroll is outlined in red, with a white background and blue letters.



*In the mid-1950s, the squadron modified the hawk insignia. This insignia was used by VA-72 for 35 years until its disestablishment.*

Nickname: Hawks, circa early 1950s-early 1960s.

Blue Hawks, early 1960s-1991.

### Chronology of Significant Events

**Sep-Dec 1946:** Participated in *Leyte* (CV 32) shakedown cruise in the Caribbean and a goodwill cruise to South

America for the inauguration of Chile's President.

**19 Aug 1948:** Squadron commanding officer, Lieutenant Commander B. F. Haker, lost at sea while attempting a carrier approach.

**25 Jan 1949:** Cross deck operations with the British carrier HMS *Triumph* in the Mediterranean.

**Apr 1961:** The squadron operated from *Independence* (CVA 62) in an area south of Guantanamo Bay, Cuba, during the Bay of Pigs, the unsuccessful invasion of Cuba by American supported Cuban exiles.

**22 Oct-22 Nov 1962:** Participated in the Cuban Quarantine while embarked in *Independence*.

**10-16 May 1963:** A detachment of three aircraft deployed in *Wasp* (CVS 18) to provide courier service during a Mercury Project space flight of the Faith 7 capsule.

**17 Oct 1965:** The squadron's executive officer, Commander H. B. Southworth, led the first successful strike against a surface-to-air SA-2 missile installation in North Vietnam. The strike was composed of four VA-72 A-4Es and one A-6A from VA-75.

**18 Sep 1970:** While operating in the Caribbean aboard *John F. Kennedy* (CVA 67), the squadron was ordered to deploy with the carrier to the Mediterranean due to the fighting between Jordanian and Palestinian forces and the intervention of Syria on behalf of the Palestinians.

**Oct 1973:** With the outbreak of war in the Middle East (Yon Kippur War), *Kennedy* and her air wing, while operating in the North Atlantic after just completing a Mediterranean deployment, were ordered back to the Mediterranean. VA-72 conducted flight operations while the carrier was on station south of Crete, from the latter part of October through mid November.

**17-19 Sep 1985:** VA-72, along with other units of CVW-1, were the first to conduct flight operations from a carrier operating inside a fjord. *America* (CV 66) operated in Vestfjord, Norway, during this evolution.

**22–27 Mar 1986:** During Freedom of Navigation Exercises in the Gulf of Sidra and the resulting combat action with Libyan forces, VA-72 flew patrols to protect the task force from attack by surface ships or submarines and also provided tanker missions for fighters flying combat air patrols.

**14 Apr 1986:** The United States initiated Operation Eldorado Canyon, air strikes against targets in Libya. VA-72 provided air-to-surface missile support for possible employment against surface-to-air missile radar sites.

**Sep–Oct 1990 and Dec 1990–Jan 1991:** The squadron participated in Operation Desert Shield, the build up of American and Allied forces to counter a threatened invasion of Saudi Arabia by Iraq and as part of an economic blockade of Iraq to force its withdrawal from Kuwait.

**17 Jan 1991:** Operation Desert Storm, combat operations to remove Iraqi forces from Kuwait, was launched. The squadron's A-7E Corsair IIs participated in the first combat strike against Iraqi targets in Baghdad.

**29 Jan 1991:** Squadron aircraft flew their first combat mission in the Kuwait theater, striking Iraqi troops, tanks and artillery positions.

**27 Feb 1991:** Squadron aircraft participated in the last naval air combat strike of the war, hitting retreating Iraqi troops east of An Najef, Iraq. During the 43 days of war the squadron flew 362 sorties without the loss of a pilot or aircraft.

**8 Jun 1991:** The last two squadron aircraft participated in the Desert Storm Victory Parade Fly Over in Washington, D.C.



A VBF-18 F8F Bearcat on Leyte's (CV 32) flight deck during her goodwill cruise to South America in 1946. In the background are other Carrier Air Group 18 aircraft.

### Home Port Assignments

<i>Location</i>	<i>Assignment Date</i>
NAS Astoria	25 Jan 1945
NAS San Diego	22 Apr 1945
NAS Quonset Point	14 Nov 1945
NAS Oceana	03 Sep 1957
NAS Cecil Field	15 Feb 1966

### Commanding Officers

	<i>Date Assumed Command</i>
LT Mohl C. Norton, Jr. (Acting)	25 Jan 1945
LCDR Jeremy Morrison	05 Mar 1945
CDR Sam E. Clark	14 Sep 1945
LCDR Frank Malinasky	11 Jun 1947
LCDR Burton F. Haker	06 Jul 1948
LT G. F. Colleran (acting)	19 Aug 1948
LCDR Frank Malinasky	20 Oct 1948
LCDR Carlton H. Clark	20 Jun 1949
LCDR John B. Jorgensen	04 Jul 1950
LCDR Archibald W. Curtis	09 Jul 1951
CDR Gordon J. Brown	Jan 1953
LCDR Carlton F. Naumann	12 Nov 1954
LCDR Robert F. Hunt	08 Feb 1956
CDR C. K. Ruiz	23 Jul 1957
CDR John K. Beling	04 Feb 1959
CDR C. A. Hill, Jr.	04 Mar 1960
CDR W. W. Kendall Miller, Jr.	12 May 1961
CDR Frederick S. Gore	16 Apr 1962
CDR T. L. Neilson	25 Mar 1963
CDR Grover C. Walker	17 Feb 1964
CDR Joe D. Adkins	10 Feb 1965
CDR Harrison B. Southworth	11 Feb 1966
CDR E. J. Hofstra	15 Mar 1967
CDR R. A. Phillips	15 Mar 1968
CDR S. E. Latimer, Jr.	10 Apr 1969
CDR D. B. Young, Jr.	17 Oct 1969
CDR R. K. Shea	09 Sep 1970
CDR M. G. Basford	02 Jul 1971
CDR J. F. Donahue	08 Jul 1972
CDR Robert J. Kelly	14 Jul 1973
CDR Edward D. Estes	12 Sep 1974
CDR Robert F. Brennock	16 Oct 1975
CDR Patrick M. Commons	16 Dec 1976
CDR Hugh A. Merrill	06 Apr 1978
CDR Howard E. Koss	Jul 1979
CDR Carter B. Refo	Oct 1980
CDR Robert L. Kiem	16 Feb 1982
CDR C. A. Cook	09 Jun 1983
CDR Arthur F. Richardson	21 Nov 1984
CDR Gordon G. Stewart	03 May 1986
CDR James B. Waddell	15 Oct 1987
CDR John R. Sanders	15 Jun 1989



A F9F-5 Panther on Bennington's (CVA 20) elevator during her cruise to the Med in 1953–1954. This particular squadron F9F was assigned to Captain H. E. Ball, an Air Force exchange pilot with VF-72.

### **Aircraft Assignment**

<i>Type of Aircraft</i>	<i>Date Type First Received</i>
F6F-3/5	07 Feb 1945
F8F-1	10 Aug 1945
F8F-1B	Jan 1947
F8F-2	20 Mar 1948
F8F-1	01 Dec 1948
F8F-1B	09 Feb 1950
F9F-2	16 Mar 1951
F9F-5	11 Oct 1951
F9F-2	Feb 1952

### **Aircraft Assignment—Continued**

<i>Type of Aircraft</i>	<i>Date Type First Received</i>
F9F-5	Feb 1953
A4D-1	Sep 1956
A4D-2	12 Feb 1958
A4D-2N/A-4C*	Mar 1961
A-4E	May 1964
A-4B	Mar 1967
A-7B	Jan 1970
A-7E	13 Sep 1977

\* The A4D-2N designation was changed to A-4C in 1962.



**Major Overseas Deployments**

<i>Date of Departure</i>	<i>Date of Return</i>	<i>Air Wing</i>	<i>Carrier</i>	<i>Type of Aircraft</i>	<i>Area of Operation</i>
16 Sep 1946	12 Dec 1946	CVG-18	CV 32	F8F-1	Carib/East Coast of South America
03 Apr 1947	09 Jun 1947	CVAG-7	CV 32	F8F-1B	Med
30 Jul 1947	19 Nov 1947	CVAG-7	CV 32	F8F-1B	Med
04 Jan 1949	23 May 1949	CVG-7	CV 47	F8F-1	Med
10 Jul 1950	10 Nov 1950	CVG-7	CVB 41	F8F-1B	Med
20 May 1952	08 Jan 1953	CVG-7	CV 31	F9F-2	WestPac/Korea
16 Sep 1953	21 Feb 1954	CVG-7	CVA 20	F9F-5	NorLant/Med
02 Sep 1958	12 Mar 1959	CVG-7	CVA 15	A4D-2	Med
04 Aug 1960	03 Mar 1961	CVG-7	CVA 62	A4D-2	Med
04 Aug 1961	19 Dec 1961	CVG-7	CVA 62	A4D-2N	Med
19 Apr 1962	27 Aug 1962	CVG-7	CVA 62	A4D-2N	Med
06 Aug 1963	04 Mar 1964	CVG-7	CVA 62	A-4C	Med
08 Sep 1964	05 Nov 1964	CVW-7	CVA 62	A-4E	NorLant/Med
10 May 1965	13 Dec 1965	CVW-7	CVA 62	A-4E	WestPac/Vietnam
21 Jun 1966	21 Feb 1967	CVW-1	CVA 42	A-4E	WestPac/Vietnam
24 Aug 1967	19 May 1968	CVW-1	CVA 42	A-4B	Med
07 Jan 1969	29 Jul 1969	CVW-8	CVA 38	A-4B	Med
14 Sep 1970	01 Mar 1971	CVW-1	CVA 67	A-7B	Carib/Med/NorLant
01 Dec 1971	06 Oct 1972	CVW-1	CVA 67	A-7B	Med/NorLant
16 Apr 1973	01 Dec 1973	CVW-1	CVA 67	A-7B	Med/NorLant/Med
28 Jun 1975	27 Jan 1976	CVW-1	CV 67	A-7B	Med
02 Sep 1976	09 Nov 1976	CVW-1	CV 67	A-7B	NorLant
15 Jan 1977	01 Aug 1977	CVW-1	CV 67	A-7B	Med
29 Jun 1978	08 Feb 1979	CVW-1	CV 67	A-7E	Med
04 Aug 1980	28 Mar 1981	CVW-1	CV 67	A-7E	Med
23 Aug 1982	30 Oct 1982	CVW-1	CV 66	A-7E	NorLant/Med/Carib
08 Dec 1982	02 Jun 1983	CVW-1	CV 66	A-7E	Med/IO
24 Apr 1984	14 Nov 1984	CVW-1	CV 66	A-7E	Carib/Med/IO
24 Aug 1985	09 Oct 1985	CVW-1	CV 66	A-7E	NorLant
10 Mar 1986	10 Sep 1986	CVW-1	CV 66	A-7E	Med
29 Feb 1988	29 Aug 1988	CVW-7	CVN 69	A-7E	Med
15 Aug 1990	28 Mar 1991	CVW-3	CV 67	A-7E	Med/Red Sea



A squadron A-4 Skyhawk launches from Independence (CVA 62). Notice the combat markings on the aircraft just forward of the jet intake showing the number of combat sorties flown by the aircraft.

**Air Wing Assignments**

<i>Air Wing Tail</i>	<i>Code</i>	<i>Assignment Date</i>
CVG-18/CVAG-7/CVG-7/ CVW-7*	L/AG†	25 Jan 1945
CVW-1	AB	07 Mar 1966
CVW-8	AJ	26 Aug 1968
RCVW-4‡	AD	22 Sep 1969
CVW-1	AB	02 Mar 1970
CVW-7	AG	01 Oct 1986
COMLATWING 1§		Sep 1988
CVW-3	AC	01 Mar 1989

\* CVG-18 was redesignated CVAG-7 on 15 November 1946. On 1 September 1948, CVAG-7 was redesignated CVG-7. CVG-7 was redesignated CVW-7 when Carrier Air Group (CVG) designations were redesignated Carrier Air Wings (CVW) on 20 December 1963.

† The tail code was changed from L to AG in 1957. The effective date for this change was most likely the beginning of FY 58 (1 July 1957).

‡ The squadron was assigned to RCVW-4 during its transition to the A-7B.

§ The squadron detached from CVW-7 and came under the operational and administrative control of Commander Light Attack Wing 1.

**Unit Awards Received**

<i>Unit Award</i>	<i>Inclusive Dates Covering Unit Award</i>	
NAVE	01 Jan 1970	30 Jun 1971
AFEM	24 Oct 1962	20 Nov 1962
	15 Jun 1965	
	29 Jun 1965	03 Jul 1965
MUC	29 Sep 1970	31 Oct 1970

**Unit Awards Received—Continued**

<i>Unit Award</i>	<i>Inclusive Dates Covering Unit Award</i>	
	01 Dec 1977	01 Mar 1979
	29 Aug 1985	20 Sep 1985
NEM	18 Oct 1962	23 Oct 1962
	01 Jan 1983	20 Jan 1983
	06 May 1983	08 May 1983
	21 Mar 1986	27 Jun 1986
NUC	05 Jun 1965	21 Nov 1965
	23 Mar 1986	17 Apr 1986
	17 Jan 1991	28 Feb 1991
RVNGC	21 Oct 1965	
	23 Oct 1965	
	25 Oct 1965	02 Nov 1965
	09 Nov 1965	10 Nov 1965
SLOC	04 Aug 1980	28 Mar 1981
	23 Aug 1982	02 Jun 1983
VNSM	04 Jul 1965	09 Aug 1965
	25 Aug 1965	21 Sep 1965
	14 Oct 1965	12 Nov 1965
	30 Jul 1966	
	09 Aug 1966	12 Sep 1966
	01 Oct 1966	03 Oct 1966
	19 Oct 1966	14 Nov 1966
	24 Nov 1966	28 Dec 1966
	20 Jan 1967	21 Jan 1967
KSM	18 Jun 1952	24 Dec 1952
KLM	17 Jan 1991	28 Feb 1991
SASM	14 Sep 1990	12 Mar 1991



*A flight of squadron A-7 Corsair IIs.*

## VA-75

### Lineage

Established as Torpedo Squadron EIGHTEEN (VT-18) on 20 July 1943.

Redesignated Attack Squadron EIGHT A (VA-8A) on 15 November 1946.

Redesignated Attack Squadron SEVENTY FIVE (VA-75) on 27 July 1948.

Disestablished on 30 November 1949. The first squadron to be designated VA-75.

### Squadron Insignia and Nickname

The squadron's first insignia was in use by the squadron prior to its approval by CNO on 24 March



*The Carrier Clowns insignia was used by VT-18.*

1945. Colors for "The Carrier Clowns" insignia were: a blue background with an orange center and a dark blue strip through the center; the words "The Carrier Clowns" in black; a white Zebra with black markings; a black bird with white markings; orange bombs; and a torpedo with yellow tip,

a white front section and the remainder in black.

Following the squadron's redesignation a new insignia was approved by CNO on 30 December 1946. Colors for the knight insignia were: a rust background with a gold border; a white horse with blue bridle and gold harness; the shield was blue with a gold anchor; a silver knight holding a gold torpedo. The squadron continued to use this insignia following its redesignation to VA-75.

Nickname: The Carrier Clowns, circa 1943–1946.



*Following the squadron's redesignation to attack, the knight insignia was approved*

### Chronology of Significant Events

24–26 Oct 1944: The squadron participated in the Battle for Leyte Gulf. On 24 October VT-18's TBMs flew sorties against a powerful Japanese surface force

in the Sibuyan Sea. These attacks contributed to the sinking of the *Musashi*, one of the two largest battle-ships in the world. On 25 October, the squadron's planes were part of a Fast Carrier Task Force that attacked a Japanese carrier force in the Battle of Cape Engano. Four Japanese carriers were sunk during that engagement. On the 26th, squadron planes participated in an attack on the Japanese surface force which was retiring from the Battle Off Samar.

**Sep-Dec 1946:** The squadron participated in *Leyte* (CV 32) shake-down cruise in the Caribbean and a goodwill cruise to South America for the inauguration of Chile's President.

### Home Port Assignments

Location	Assignment Date
NAS Alameda	20 Jul 1943
NAAS Monterey	28 Oct 1943*
NAAS Hollister	Nov 1943*
NAS Hilo	Feb 1944*
NAS Kaneohe	Jun 1944*
NAS Alameda	20 Dec 1944
NAS Astoria	25 Jan 1945
NAS San Diego	22 Apr 1945
NAS Quonset Point	14 Nov 1945

\* Temporary shore assignments while the squadron conducted training in preparation for combat deployment.

### Commanding Officers

	Date Assumed Command
LTJG Al Long (acting)	20 Jul 1943
LCDR Lloyd W. Van Antwerp	02 Aug 1943
ENS Joseph B. Baker (acting)	25 Jan 1945
LT John G. Williams (acting)	31 Jan 1945
LT John G. Williams	25 Apr 1945
LT Jack C. Heishman	19 Sep 1945
LCDR James L. Hooper	04 Feb 1946
LCDR Charles A. Iarrobino	01 Dec 1947
CDR Morris R. Doughty	13 Oct 1948

### Aircraft Assignment

Type of Aircraft	Date Type First Received
TBF-1	Jul 1943
TBM-1	Sep 1943
TBM-1C	Nov 1943
TBM-3	Feb 1945
TBM-3E	22 Apr 1945
TBM-3Q	06 May 1946
AD-3	18 Apr 1949

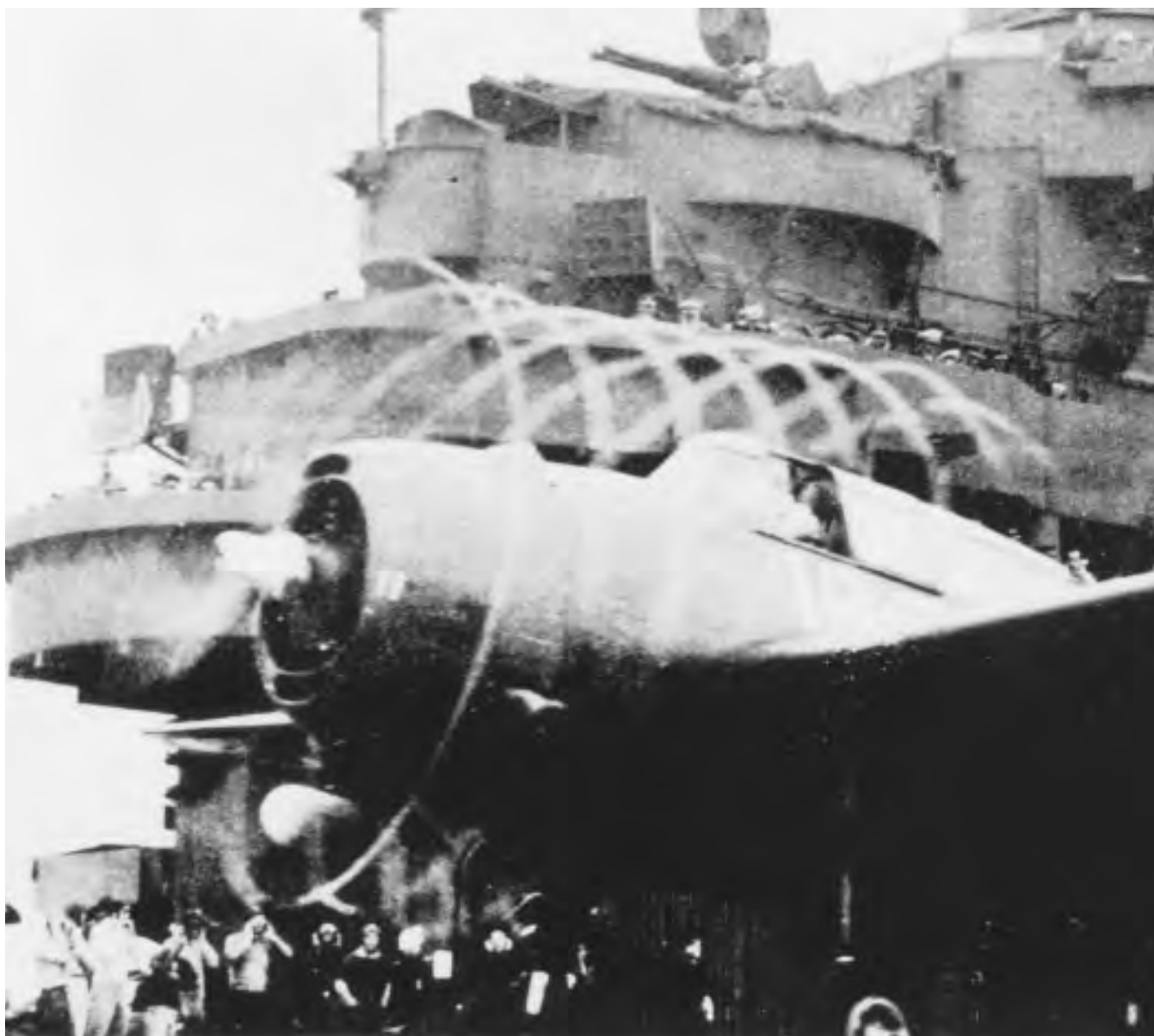

*A squadron TBM-3 takes off from Leyte (CV 32) during its goodwill cruise to South America in 1946.*

### **Major Overseas Deployments**

<i>Date of Departure</i>	<i>Date of Return</i>	<i>Air Wing</i>	<i>Carrier</i>	<i>Type of Aircraft</i>	<i>Area of Operation</i>
16 Aug 1944	20 Dec 1944	CVG-18	CV 11	TBM-1C	Pacific
16 Sep 1946	12 Dec 1946	CVG-18	CV 32	TBM-3E/Q	Carib/East Coast of South America
03 Apr 1947	09 Jun 1947	CVAG-7	CV 32	TBM-3E/Q & TBM-3J	Med
30 Jul 1947	19 Nov 1947	CVAG-7	CV 32	TBM-3E/Q	Med
04 Jan 1949	23 May 1949	CVG-7	CV 47*	TBM-3E/Q	Med

\* Only half of the squadron's personnel and aircraft deployed aboard *Philippine Sea* (CV 47), the other half remained at NAS Quonset Point.

**Air Wing Assignments**

<i>Air Wing</i>	<i>Tail Code</i>	<i>Assignment Date</i>
CVG-18/CVAG-7/CVG-7*	L†	20 Jul 1943

\* CVG-18 was redesignated CVAG-7 on 15 November 1946 and then redesignated CVG-7 on 1 September 1948.

† The tail code L was assigned to CVAG-7 in December 1946.

**Unit Awards Received**

<i>Unit Award</i>	<i>Inclusive Dates Covering Unit Award</i>	
WW-II Campaign Medal (Asiatic/Pacific)	Oct 1944	Nov 1944



*A squadron AD-4 Skyraider launches from deck of Bon Homme Richard (CVA 31), November 1952 (Courtesy Robert Lawson Collection).*

## SECOND VA-75

### Lineage

Established as Bombing Squadron EIGHTEEN (VB-18) on 20 July 1943.

Redesignated Attack Squadron SEVEN A (VA-7A) on 15 November 1946.

Redesignated Attack Squadron SEVENTY FOUR (VA-74) on 27 July 1948.

Redesignated Attack Squadron SEVENTY FIVE (VA-75) on 15 February 1950. The second squadron to be assigned the VA-75 designation.

### Squadron Insignia and Nickname

The squadron's first insignia was approved by CNO on 14 January 1944. Colors for the Sunday Punchers winged glove and bomb insignia were: white background with royal blue outlines and lettering; the glove was dark brown with yellow lacing; wings were yellow with black outlines; and the bomb was black with black and yellow fins.

*The winged glove was the squadron's first insignia used between 1944 to 1947. It was readopted sometime after 1950.*

for the insignia of a boy riding a bomb were: a light blue background outlined in gold; Sunday Punchers lettering was medium blue and the VA-7A lettering on the trunks was gold; the bomb was medium blue with black highlights; the boy had tan skin with red cheeks, yellow hair, black eyes; wearing red trunks and black boots with white tops; the gloves were brown.



*This insignia was used by the squadron from 1947 to sometime around 1950.*

Following the squadron's redesignation in 1946, a new insignia was approved by CNO on 25 June 1947. Colors

for the insignia of a boy riding a bomb were: a light blue background outlined in gold; Sunday Punchers lettering was medium blue and the VA-7A lettering on the trunks was gold; the bomb was medium blue with black highlights; the boy had tan skin with red cheeks, yellow hair, black eyes; wearing red trunks and black boots with white tops; the gloves were brown.

Sometime after the squadron's redesignation to VA-75 it reverted to the winged glove and bomb insignia. The colors are the same as those used in the previously approved insignia.

### Chronology of Significant Events

**5 Feb 1944:** Lieutenant Commander Dickson, the squadron's commanding officer, was killed in a training exercise when his aircraft went into a high speed stall and crashed during a practice dive.

**12 Oct 1944:** Squadron commanding officer, Commander Mark Eslick, was lost in combat during an attack on Kiirun Harbor, Formosa.

**24–26 Oct 1944:** The squadron participated in the Battle for Leyte Gulf, part of the operations surrounding the occupation of Leyte. On 24 October VB-18's SB2Cs flew sorties against a powerful Japanese surface force in the Sibuyan Sea. These attacks contributed to the sinking of the mighty *Musashi*, one of the two largest battleships in the world. On 25 October the squadron's planes were part of a Fast Carrier Task Force that attacked the Japanese carrier force in the Battle of Cape Engano. Four Japanese carriers were sunk during this engagement. On the 26th, squadron planes participated in attacks on the Japanese surface force which was retiring from the Battle Off Samar.

**24 Oct 1944:** While assigned to VB-18, Lieutenant Donald L. Wilson was awarded the Navy Cross for scoring a direct hit on a Japanese battleship during the Battle for Leyte Gulf. Following World War II, Lieutenant Wilson became the squadron's commanding officer.

**25 Oct 1944:** The squadron's commanding officer, Lieutenant Commander George D. Ghesquiere was awarded the Navy Cross for leading his squadron in an attack against a Japanese carrier task force during the Battle of Cape Engano, in which he scored a direct hit on a Japanese carrier.

**26 Oct 1944:** Lieutenant Benjamin G. Preston was awarded a Gold Star in lieu of his third Navy Cross for leading a division of dive bombers in an attack against the Japanese carrier task force during the Battle of Cape Engano. In 1953 he became the commanding officer of the squadron.

**Sep–Dec 1946:** The squadron participated in *Leyte* (CV 32) shake-down cruise in the Caribbean and a goodwill cruise to South America for the inauguration of Chile's President.

**25 Jan 1949:** Cross deck operations with the British carrier HMS *Triumph* in the Mediterranean.

**23 Jun 1952:** The squadron's first combat action in Korea was a joint operation with Air Group 7 and the U.S. Air Force in an attack against hydro-electric complexes in North Korea that had previously been restricted from attack.

**11 Jul 1952:** The squadron participated in a combined attack against Pyongyang, North Korea, with aircraft from CVG-7, *Princeton* (CV 37), the U.S. Air Force, Marine Corps, Australian Air Force and British Royal Navy.

**5 Dec 1952:** On a strike against enemy troop concentrations the squadron's commanding officer, Commander H. K. Evans, was lost when his aircraft was hit by anti-aircraft fire and crashed.

**Apr 1961:** The squadron operated from *Independence* (CVA 62) in an area south of Guantanamo Bay, Cuba, during the Bay of Pigs, the unsuccessful invasion of Cuba by American supported Cuban exiles.

**22 Oct–22 Nov 1962:** Participated in the Cuban Quarantine while embarked in *Independence*.

**14 Nov 1963:** The first operational fleet squadron to be assigned the A-6A Intruder.

**May–Dec 1965:** VA-75 was the first squadron to deploy with the A-6A Intruder and operate the aircraft in a combat environment.

**18 Sep 1965:** The squadron's commanding officer, Commander Leonard Vogt, was lost during a combat mission while engaged in a night bombing attack on enemy patrol boats.

**24 Feb 1968:** Commander Jerrold M. Zacharias and Lieutenant Commander Michael L. Hall were awarded the Navy Cross for their action with VA-35 in planning and executing a coordinated A-6A strike on Hanoi.

**Sep and Oct 1970:** VA-75 operated from *Saratoga* (CVA 60) while on station in the eastern Mediterranean during the continuing crisis with the Palestinians in Jordan and the invasion of Jordan by Syria.

**7 Oct 1971:** VA-75 became the first A-6 squadron to drop sonobuoys. The integrated A-6A radar system and the A-6B antiradiation system were utilized for exact positioning and release of the sonobuoys. This event was part of an overall evaluation of the CV Concept being conducted by the *Saratoga* to determine the carrier's capability to operate effectively in both the attack and ASW roles.

**Jun–Oct 1972:** Participated in Linebacker I operations, heavy air strikes against targets in North Vietnam and mining operations along coastal waters.

**6 Aug 1972:** Commander Charles Earnest and Lieutenant Commander Grady L. Jackson were awarded the Silver Star for directing a successful night inland rescue of a downed pilot in a heavily defended area of North Vietnam.

**10 Oct 1972:** Lieutenant Commander John A. Pieno and Lieutenant Junior Grade John R. Fuller were awarded the Silver Star for their actions as bombardier/navigators of a two plane attack, at dusk, on the North Vietnamese airfield of Bai Thong.

**28 Nov 1972:** The squadron's commanding officer, Commander Charles Earnest, was lost in an aircraft accident following a catapult launch from *Saratoga* while operating on Yankee Station.

**19–29 Dec 1972:** Participated in Linebacker II operations, the resumption of heavy bombing strikes above the 20th parallel in North Vietnam. This operation concentrated attacks around Hanoi and the coastal areas of Haiphong.

**18 Jan 1975:** Following violent demonstrations against the American Embassy in Nicosia, Cyprus, VA-75 operated from *Saratoga* off the coast of Cyprus.

**Apr 1976:** As tensions increased in Lebanon, *Saratoga* and her air wing wing operated south of Crete, prepared to provide support for the evacuation of Americans from that country if it became necessary.

**8 Jan 1980:** The squadron's commanding officer, Commander A. J. Lynch, and Lieutenant Charles J. Morrow were lost when their aircraft struck several parked planes during a night landing and careened into the sea.

**Jun 1982:** Israel invaded Lebanon and *John F. Kennedy* (CV 67) was ordered to operate off the coast of Lebanon. VA-75 operated from the carrier, preparing for possible air support if it became necessary to evacuate Americans from Beirut, Lebanon.

**4 Dec 1983:** During *Kennedy's* operations off the coast of Lebanon in support of the Multinational Peacekeeping Force, several of the carrier's F-14 reconnaissance aircraft received hostile fire from Syrian surface-to-air missile and anti-aircraft positions on 3 December. A retaliatory strike was flown by elements from CVW-3 and aircraft from *Independence* (CV 62) against the Syrian anti-aircraft positions near Hammana, Lebanon. The squadron's commanding officer, Commander Glover, led three of VA-75's A-6Es in the strike and succeeded in destroying an anti-aircraft position. VA-75 also provided two KA-6D tanker aircraft for the operation.

**6 Feb 1984:** VA-75 launched its alert aircraft from *Kennedy* in response to a request from U.S. Marines (part of the Multinational Peacekeeping Force) at the Beirut International Airport to suppress attacks against their positions. The squadron's A-6E dropped its laser guided bombs on the enemy positions and effectively ended the attack.

**Feb 1987:** With the increased tensions in Lebanon surrounding the American hostages, *Kennedy* was ordered to operate off the coast of Lebanon. VA-75 flew operations from the carrier in preparation for possible evacuation.

**Jan 1989:** During routine training exercises off the northeastern tip of Libya, two F-14 Tomcats were approached by two Libyan MiG-23 jets, and after repeated attempts for a peaceful intercept, the F-14s shot down the Libyan aircraft. VA-75's KA-6D tankers provided refueling support for the two F-14s involved in the shoot down.

**Aug 1989:** During a training exercise, a squadron A-6E SWIP aircraft was the first to fire a Sidewinder (AIM-9H) air-to-air missile, scoring a direct hit with the missile.

**Sep–Oct 1990 and Dec 1990–Jan 1991:** The squadron participated in Operation Desert Shield, the build up of American and Allied forces to counter a threatened invasion of Saudi Arabia by Iraq and as part of an economic blockade of Iraq to force its withdrawal from Kuwait.



A squadron SB2C-5 Helldiver on a flight over Valparaiso Harbor during its goodwill cruise to South America aboard *Leyte* (CV 32) in 1946.

### Home Port Assignments

<i>Location</i>	<i>Assignment Date</i>
NAS Alameda	20 Jul 1943
NAAS Watsonville	26 Sep 1943*
NAAS Crows Landing	10 Dec 1943*
NAS Hilo	29 Feb 1944*
NAS Kaneohe	05 Jun 1944*
NAS Alameda	20 Dec 1944
NAS Astoria	25 Jan 1945
NAS San Diego	22 Apr 1945
NAS Quonset Point	27 Nov 1945
NAS Oceana	Oct 1957

\* Temporary shore assignments while the squadron conducted training in preparation for combat deployment.

### Commanding Officers

	<i>Date Assumed Command</i>
LCDR Charles C. Gold	20 Jul 1943
LCDR Harlan R. Dickson	27 Nov 1943
LCDR George D. Ghesquiere	05 Feb 1944
LCDR Mark Eslick, Jr.	12 Feb 1944
LCDR George D. Ghesquiere	12 Oct 1944
LT Max H. Matzick (acting)	25 Jan 1945
LT Donald L. Wilson (acting)	01 Feb 1945
LT Donald L. Wilson	25 Apr 1945
LCDR William D. Carter	19 Aug 1946
LCDR L. Weidlein (acting)	15 Jun 1948
LCDR William B. Morton	21 Jun 1948
LCDR Nils R. Larson	16 Dec 1949
LCDR H. K. Evans	10 Mar 1951
LCDR W. M. Harnish (acting)	05 Dec 1952

### Commanding Officers—Continued

	<i>Date Assumed Command</i>
CDR Benjamin G. Preston	Jan 1953
CDR Griffith P. Stokes	Sep 1954
CDR Samuel M. Tharp, Jr.	Jan 1956
CDR Clifford L. Brown	02 May 1957
CDR C. R. Anderson	02 Jul 1958
CDR C. S. Curtis	10 Jul 1959
CDR Stanley Montunnas	May 1960
CDR Alphonse G. Goodberlet	Apr 1961
CDR K. H. Lyons	13 Apr 1962
CDR J. A. Denton, Jr.	05 Apr 1963
CDR William L. Harris, Jr.	02 Aug 1963
CDR Leonard A. Snead	08 May 1964
CDR Leonard F. Vogt, Jr.	1965
CDR William B. Warwick	18 Sep 1965
CDR Robert J. Sample	08 Jul 1966
CDR Jerrold M. Zacharias	30 Jun 1967
CDR Alastair S. Falconer	31 Jul 1968
CDR Richard P. Bordone	25 Jul 1969
CDR Charles J. Cellar, Jr.	03 Jul 1970
CDR Everett W. Foote	03 Jun 1971
CDR Charles M. Earnest	07 Jun 1972
CDR William H. Greene, Jr.	28 Nov 1972
CDR Morgan M. France	22 Feb 1974
CDR Melvin L. Seidel	07 Apr 1975
CDR David L. Osburn	02 Jul 1976
CDR Kenneth R. Werhan	18 Oct 1977
CDR Anthony J. Lynch	12 Jan 1979
CDR Rodney A. Bankson	08 Jan 1980
CDR Joseph S. Mobley	30 Jan 1981
CDR Earl D. Wolfgang	19 Mar 1982
CDR James R. Glover	13 Oct 1983
CDR Gregory C. Brown	03 Apr 1985
CDR Alfred G. Harms, Jr.	26 Oct 1986
CDR John T. Meister	14 Apr 1988
CDR Robert E. Besal	29 Sep 1989



A squadron F4U-4 Corsair launches from *Bon Homme Richard* (CV 31), circa 1952 (Courtesy Robert Lauson Collection).



**Aircraft Assignment**

<i>Type of Aircraft</i>	<i>Date Type First Received</i>
SBD-5	20 Jul 1943
SB2C-1	25 Mar 1944
SB2C-1C	25 Apr 1944
SB2C-3	10 Jul 1944
SB2C-4	Feb 1945
SB2C-4E	Mar 1945
SBW-5	Jul 1946
SB2C-5	Jul 1946
F4U-4B	15 Apr 1948
F4U-4	Dec 1948

**Aircraft Assignment—Continued**

<i>Type of Aircraft</i>	<i>Date Type First Received</i>
AD-3	Jun 1949
AD-4	Jun 1950
AD-6/A-1H*	Aug 1954
AD-5	Apr 1956
A-6A	14 Nov 1963
A-6B	21 Dec 1967
KA-6D	18 Dec 1970
A-6E	06 Aug 1973

\* The AD-6 designation was changed to A-1H in 1962.

**Major Overseas Deployments**

<i>Date of Departure</i>	<i>Date of Return</i>	<i>Air Wing</i>	<i>Carrier</i>	<i>Type of Aircraft</i>	<i>Area of Operation</i>
16 Aug 1944	20 Dec 1944	CVG-18	CV 11	SB2C-3	Pacific
16 Sep 1946	12 Dec 1946	CVG-18	CV 32	SB2C-5/ SBW-5	Carib/East Coast of South America
03 Apr 1947	09 Jun 1947	CVAG-7	CV 32	SB2C-5/SBW-5	Med
30 Jul 1947	19 Nov 1947	CVAG-7	CV 32	SB2C-5	Med
04 Jan 1949	23 May 1949	CVG-7	CV 32	F4U-4	Med
10 Jul 1950	10 Nov 1950	CVG-7	CVB 41	AD-4	Med
20 May 1952	08 Jan 1953	CVG-7	CV 31	AD-4	WestPac/Korea
16 Sep 1953	21 Feb 1954	CVG-7	CVA 20	AD-4	NorLant/Med
04 May 1955	10 Dec 1955	CVG-7	CVA 12	AD-6	WestPac
03 Sep 1957	22 Oct 1957	CVG-7	CVA 60	AD-6	NorLant
02 Sep 1958	12 Mar 1959	CVG-7	CVA 15	AD-6	Med
04 Aug 1960	03 Mar 1961	CVG-7	CVA 62	AD-6	Med
04 Aug 1961	19 Dec 1961	CVG-7	CVA 62	AD-6	Med
19 Apr 1962	27 Aug 1962	CVG-7	CVA 62	AD-6	Med
10 May 1965	13 Dec 1965	CVW-7	CVA 62	A-6A	WestPac/Vietnam
13 Jun 1966	01 Feb 1967	CVW-7	CVA 62	A-6A	Med
18 Nov 1967	28 Jun 1968	CVW-11	CVA 63	A-6A/B	WestPac/Vietnam
09 Jul 1969	22 Jan 1970	CVW-3	CVA 60	A-6A	Med
17 Jun 1970	09 Nov 1970	CVW-3	CVA 60	A-6A/B	Med
07 Jun 1971	28 Oct 1971	CVW-3	CVA 60	A-6A/B & KA-6D	NorLant/Med
11 Apr 1972	13 Feb 1973	CVW-3	CVA 60	A-6A/B & KA-6D	WestPac/Vietnam
27 Sep 1974	19 Mar 1975	CVW-3	CV 60	A-6E & KA-6D	Med
06 Jan 1976	28 Jul 1976	CVW-3	CV 60	A-6E & KA-6D	Med
11 Jul 1977	23 Dec 1977	CVW-3	CV 60	A-6E & KA-6D	Med
03 Oct 1978	08 Apr 1979	CVW-3	CV 60	A-6E & KA-6D	Med
10 Mar 1980	27 Aug 1980	CVW-3	CV 60	A-6E & KA-6D	Med
04 Jan 1982	14 Jul 1982	CVW-3	CV 67	A-6E & KA-6D	Med/IO
25 May 1983	01 Jul 1983	CVW-3	CV 67	A-6E & KA-6D	NorLant
27 Sep 1983	02 May 1984	CVW-3	CV 67	A-6E & KA-6D	SoLant/Med
18 Aug 1986	03 Mar 1987	CVW-3	CV 67	A-6E & KA-6D	Med
02 Aug 1988	01 Feb 1989	CVW-3	CV 67	A-6E & KA-6D	Med
15 Aug 1990	28 Mar 1991	CVW-3	CV 67	A-6E & KA-6D	Med/Red Sea



*A formation of squadron AD-6 Skyraiders.*

### **Air Wing Assignments**

<i>Air Wing</i>	<i>Tail Code</i>	<i>Assignment Date</i>
CVG-18/CVAG-7/ CVG-7/CVW-7*	L/AG**	20 Jul 1943
COMFAIRNORFOLK		01 Jul 1967
CVW-11	NH	10 Oct 1967
COMFAIRNORFOLK		28 Jun 1968
CVW-3	AC	15 Oct 1968

\* CVG-18 was redesignated CVAG-7 on 15 November 1946. On 1 September 1948, CVAG-7 was redesignated CVG-7. CVG-7 was redesignated CVW-7 when Carrier Air Group (CVG) designations were redesignated Carrier Air Wings (CVW) on 20 December 1963.

\*\* The tail code was changed from L to AG in 1957. The effective date for this change was most likely the beginning of FY 58 (1 July 1957).

### **Unit Awards Received**

<i>Unit Award</i>	<i>Inclusive Dates Covering Unit Award</i>	
NUC	22 Jun 1952	18 Dec 1952
	05 Jun 1965	21 Nov 1965
	18 May 1972	08 Jan 1973
	14 Aug 1988	22 Jan 1989
	17 Jan 1991	28 Feb 1991
WW-II Campaign Medal (Asiatic/ Pacific)	Oct 1944	Nov 1944
NAVE	01 Jul 1968	31 Dec 1969
AFEM	24 Oct 1962	20 Nov 1962
	17 Jun 1965	
	29 Jun 1965	03 Jul 1965
	06 Nov 1983	27 Nov 1983
	02 Dec 1983	21 Jan 1984
	31 Jan 1984	22 Feb 1984

**Unit Awards Received—Continued**

<i>Unit Award</i>	<i>Inclusive Dates Covering Unit Award</i>	
MUC	25 Feb 1984	29 Feb 1984
	17 Sep 1970	18 Oct 1970
	01 Jan 1973	31 Dec 1973
	01 Oct 1979	15 Nov 1980
	15 Jul 1982	22 Apr 1984
NEM	18 Oct 1962	23 Oct 1962
PUC	23 Dec 1967	01 Jun 1968
VNSM	04 Jul 1965	09 Aug 1965
	25 Aug 1965	21 Sep 1965
	14 Oct 1965	12 Nov 1965
	22 Dec 1967	22 Feb 1968
	04 Mar 1968	27 Mar 1968
	12 Apr 1968	01 May 1968

**Unit Awards Received—Continued**

<i>Unit Award</i>	<i>Inclusive Dates Covering Unit Award</i>		
KSM	13 May 1968	01 Jun 1968	
	06 May 1972	07 May 1972	
	17 May 1972	22 Jun 1972	
	30 Jun 1972	16 Jul 1972	
	27 Jul 1972	23 Aug 1972	
	02 Sep 1972	19 Sep 1972	
	29 Sep 1972	21 Oct 1972	
	25 Oct 1972	26 Oct 1972	
	03 Nov 1972	08 Dec 1972	
	18 Dec 1972	31 Dec 1972	
	18 Jun 1952	24 Dec 1952	
	SASM	14 Sep 1990	28 Mar 1991
	KLM	17 Jan 1991	28 Feb 1991



*A squadron A-6E Intruder refuels from a French Super Etendard off Lebanon in 1984.*

## VA-76

### Lineage

Established as Attack Squadron SEVENTY SIX (VA-76) on 1 June 1955.

Disestablished on 30 September 1969. The first squadron to be assigned the VA-76 designation.

### Squadron Insignia and Nickname



The squadron's insignia, reflecting their motto "Fighting Spirits of 76."

The squadron's insignia was approved by CNO on 28 March 1956. The following colors were used for the insignia: blue background with a dark blue border; purple hat with black crown, red piping on brim and a white cockade; black mustache; and the scroll was gold with red lettering and outlined in dark blue.

Nickname: Spirits (from motto Fighting Spirits of 76), 1955–1969.

### Chronology of Significant Events

**Nov–Dec 1956:** The squadron operated from *Forrestal* (CVA 59) off the coast of the Azores during the Suez Crisis, awaiting a call to enter the Mediterranean if necessary.

**Jun 1961:** The squadron deployed aboard *Intrepid* (CVA 11) and operated in the Caribbean during the Dominican Republic crisis.

**19 Oct–08 Dec 1962:** The squadron deployed aboard *Enterprise* (CVAN 65) and operated in the Caribbean during the Cuban missile crisis and naval blockade.

**Mar 1964:** Conducted operations in the vicinity of Cyprus during a conflict in that country between Turkish and Greek Cypriots.

**31 Jul–3 Oct 1964:** While embarked in *Enterprise*, the squadron participated in Operation Sea Orbit, the first circumnavigation of the world by a nuclear task force. The sixty-five day voyage was accomplished without replenishment. The squadron participated in numerous air power demonstrations during the voyage.

**8–25 Feb 1965:** A detachment of the squadron's A-4C Skyhawks, configured with Sidewinder missiles, were embarked in *Essex* (CVS 9) for an Atlantic Fleet

exercise. The aircraft were used for limited daylight fighter protection for embarked ASW aircraft.

**29 May–15 Jun 1965:** While temporarily based ashore at Naval Station Roosevelt Roads, Puerto Rico, the squadron flew armed reconnaissance sorties over the Dominican Republic during a crisis in that country.

**11 May 1966:** The squadron's commanding officer, Commander J. B. Linder, was awarded the Silver Star for leading the squadron on a strike against a mobile SAM site at Thanh Hoa, North Vietnam.

**6 Dec 1966:** The squadron's commanding officer, Commander A. D. McFall, was killed when his aircraft crashed following a night launch from *Bon Homme Richard* (CVA 31).

**1 May 1967:** During a sortie against North Vietnam's MiG airfield at Kep, Lieutenant Commander Theodore R. Swartz shot down a MiG-17 with air-to-ground rockets. This was the first, and only, MiG aircraft to be downed by an A-4 Skyhawk during the Vietnam conflict. Lieutenant Commander Swartz received the Silver Star for his action.

**14 Jul 1967:** The squadron's commanding officer, Commander R. B. Fuller, was shot down during a sortie over North Vietnam. He was released from captivity on 4 March 1973 following the 27 January 1973 cease-fire agreement with North Vietnam.

### Home Port Assignments

Location	Assignment Date
NAS Oceana	01 Jun 1955
NAS Lemoore	24 Aug 1966

### Commanding Officers

	Date Assumed Command
CDR F. J. Gibson	01 Jun 1955
CDR W. R. McQuilkin	30 Jul 1957
LCDR H. R. Cheuvront	03 Oct 1958
CDR H. Ricks	04 Dec 1959
CDR L. M. Nearman	14 Dec 1960
CDR W. R. Bascom	18 Dec 1961
CDR J. R. Sanderson	15 Nov 1962
CDR George A. Reaves III	11 Dec 1963
CDR Richard C. Boyd	30 Nov 1964
CDR James B. Linder	21 Oct 1965
CDR Albert D. McFall	01 Oct 1966
CDR Robert B. Fuller (acting)	06 Dec 1966
CDR Robert B. Fuller	19 Dec 1966
LCDR R. A. Mauldin	14 Jul 1967
CDR J. J. Barth	1968
CDR R. A. Mauldin	1969



*A squadron F2H-2 Banshee in 1956.*

**Aircraft Assignment**

<i>Type of Aircraft</i>	<i>Date Type First Received</i>
F2H-2	Jul 1955
F9F-8	06 Jan 1956
F9F-8B	Apr 1956

**Aircraft Assignment—Continued**

<i>Type of Aircraft</i>	<i>Date Type First Received</i>
A4D-2	27 May 1959
A4D-2N/A-4C*	02 Mar 1962

\* The A4D-2N designation was changed to A-4C in 1962.

**Major Overseas Deployments**

<i>Date of Departure</i>	<i>Date of Return</i>	<i>Air Wing</i>	<i>Carrier</i>	<i>Type of Aircraft</i>	<i>Area of Operation</i>
15 Jan 1957	22 Jul 1957	CVG-1	CVA 59	F9F-8B	Med
09 Jun 1958	08 Aug 1958	ATG-181	CVA 11	F9F-8B	NorLant
04 Aug 1960	17 Feb 1961	CVG-6	CVA 11	A4D-2	Med
03 Aug 1961	01 Mar 1962	CVG-6	CVA 11	A4D-2	Med
03 Aug 1962	11 Oct 1962	CVG-6	CVAN 65	A4D-2N	Med
06 Feb 1963	04 Sep 1963	CVG-6	CVAN 65	A-4C	Med
08 Feb 1964	03 Oct 1964	CVW-6	CVAN 65	A-4C	Med/World Cruise
26 Oct 1965	21 Jun 1966	CVW-9	CVAN 65	A-4C	WestPac/Vietnam
26 Jan 1967	25 Aug 1967	CVW-21	CVA 31	A-4C	WestPac/Vietnam
30 Apr 1968	27 Jan 1969	CVW-7	CVA 62	A-4C	Med

**Air Wing Assignments**

<i>Air Wing</i>	<i>Tail Code</i>	<i>Assignment Date</i>
ATG-182	O*	01 Jun 1955
CVG-1	T	Nov 1956
ATG-182	AN	23 Jul 1957
ATG-181	AM	15 Mar 1958
CVG-6	AF	08 Aug 1958
CVG-8	AJ	01 Apr 1959
CVG-6/CVW-6†	AF/AE	29 Aug 1959
CVW-9	NG	22 Sep 1965

**Air Wing Assignments—Continued**

<i>Air Wing</i>	<i>Tail Code</i>	<i>Assignment Date</i>
CVW-21	NP	01 Sep 1966
CVW-7	AG	Dec 1967
COMFAIRALAMEDA		27 Jan 1969

\*The tail code O was not assigned until 24 July 1956.

† CVG-6 was redesignated CVW-6 when Carrier Air Group (CVG) designations were redesignated Carrier Air Wings (CVW) on 20 December 1963. Sometime in the latter part of 1962 CVG-6's tail code was changed from AF to AE.



*Squadron F9F-8Bs prepares for launch from Forrestal (CVA 59) during her first deployment to the Med in 1957.*

**Unit Awards Received**

<i>Unit Award</i>	<i>Inclusive Dates Covering Unit Award</i>	
AFEM	03 Jun 1965	06 Jun 1965
	24 Oct 1962	03 Dec 1962
NEM	19 Oct 1962	23 Oct 1962
	04 Jun 1961	18 Jun 1961
PUC	26 Feb 1967	30 Jul 1967
VNSM	02 Dec 1965	14 Jan 1966
	04 Feb 1966	23 Feb 1966
	16 Mar 1966	12 Apr 1966
	22 Apr 1966	14 May 1966

**Unit Awards Received—Continued**

<i>Unit Award</i>	<i>Inclusive Dates Covering Unit Award</i>	
	23 May 1966	06 Jun 1966
	25 Feb 1967	21 Mar 1967
	17 Apr 1967	07 May 1967
RVNGC	27 Jun 1967	29 Jul 1967
	02 Dec 1965	
	11 Dec 1965	
	21 Dec 1965	
	24 Dec 1965	
	26 Dec 1965	30 Dec 1965

**Unit Awards Received—Continued**

<i>Unit Award</i>	<i>Inclusive Dates Covering Unit Award</i>	
	01 Jan 1966	02 Jan 1966
	04 Jan 1966	14 Jan 1966
	04 Feb 1966	
	19 Feb 1966	
	23 Feb 1966	
	27 Mar 1966	28 Mar 1966
	30 Mar 1966	31 Mar 1966
	02 Apr 1966	
	11 Apr 1966	

**Unit Awards Received—Continued**

<i>Unit Award</i>	<i>Inclusive Dates Covering Unit Award</i>	
	29 Apr 1966	
	28 Feb 1967	
	07 Mar 1967	
	11 Mar 1967	
	13 Mar 1967	
	16 Mar 1967	
	20 Mar 1967	21 Mar 1967
	29 Apr 1967	01 May 1967
	16 May 1967	18 May 1967



*A squadron A-4C Skyhawk on the elevator of Enterprise (CVAN 65) in 1965.*

## VA-84

### *Lineage*

Established as Attack Squadron EIGHTY FOUR (VA-84) on 15 September 1948.

Disestablished on 29 November 1949. The first squadron to be assigned the VA-84 designation.

### *Squadron Insignia and Nickname*

The squadron's insignia was approved by CNO on 9 May 1949. The following colors were used in the



*The squadron's short-lived insignia.*

insignia: the four cards had a white background and were outlined in black; the card on the left had a red letter "A" with a torpedo, outlined in black, with a red tip and aft section and a yellow tailfin and mid-section; the next card had a black letter "A" with two bombs, outlined and shaded in black, with a yellow tip and aft section, red tailfin and mid-section; the third card had a red letter "A" with three missiles outlined in black, red tip and tailfins and a white mid-section; the fourth card had a black "A" with black and white crossed machine guns and red bullets with black base and tips; the airplane was blue with black and white markings, a green strip on the tail, the nose was green and white, the gloves were green with white and yellow markings and a red star outlined in black with a white center, the lips and eye of the plane were yellow with a black pupil, the teeth were white and the tongue was red; the cloud was white, outlined in black with light blue shading at the bottom.

Nickname: unknown.

### *Home Port Assignments*

<i>Location</i>	<i>Assignment Date</i>
NAAS Oceana	15 Sep 1948
NAS Jacksonville	05 Nov 1948



*Squadron pilots in front of a squadron AM-1 Mauler, circa 1948.*



**Commanding Officers**

	<i>Date Assumed Command</i>
LCDR R. P. Kline	15 Sep 1948

**Aircraft Assignment—Continued**

<i>Type of Aircraft</i>	<i>Date Type First Received</i>
AM-1	20 Nov 1948

**Aircraft Assignment**

<i>Type of Aircraft</i>	<i>Date Type First Received</i>
TBM-3E	Nov 1948

**Air Wing Assignments**

<i>Air Wing</i>	<i>Tail Code</i>	<i>Assignment Date</i>
CVG-8	E	15 Sep 1948



*A squadron AM-1 Mauler in flight, circa 1949 (Courtesy Robert Lawson Collection).*

## VA-85

### Lineage

Established as Attack Squadron EIGHTY FIVE (VA-85) on 15 September 1948.

Disestablished on 29 November 1949. The first squadron to be assigned the VA-85 designation.

### Squadron Insignia and Nickname

There are no records of an approved insignia or nickname for VA-85.

### Home Port Assignments

<i>Location</i>	<i>Assignment Date</i>
NAAS Oceana	15 Sep 1948
NAS Jacksonville	05 Nov 1948

### Commanding Officers

	<i>Date Assumed Command</i>
LCDR Frank B. Stone	15 Sep 1948

### Aircraft Assignment

<i>Type of Aircraft</i>	<i>Date Type First Received</i>
TBM-3E	Oct 1948
AM-1	30 Nov 1948

### Air Wing Assignments

<i>Air Wing</i>	<i>Tail Code</i>	<i>Assignment Date</i>
CVG-8	E	15 Sep 1948



*A squadron AM-1 Mauler aboard Midway (CVB 41) in May 1949 (Courtesy Wallace Russel Collection).*

## SECOND VA-85

### Lineage

Attack Squadron EIGHT HUNDRED FIFTY NINE (VA-859) was a reserve squadron called to active duty on 1 February 1951.

Redesignated Attack Squadron EIGHTY FIVE (VA-85) on 4 February 1953.

Disestablished on 30 September 1994. The second squadron to be assigned the VA-85 designation.

### Squadron Insignia and Nickname

The squadron's insignia was approved by CNO on 22 May 1951. Colors for the woodpecker astride a



*The squadron's first insignia.*

rocket were: a blue gray background outlined in black; brown woodpecker shaded with white and different tones of brown; the shoes, gloves and face of the bird were white; the beak and Mae West lifejacket were yellow; its eyes were green with black pupils and a red head; the bomb was dark

blue with a red flame and the rocket was shaded light green on top and dark green on the bottom, outlined in black.

Following the squadron's redesignation a new insignia was approved by CNO on 24 May 1954. Colors for the winged bomb insignia were: blue background outlined in red; the clouds and wings were silver with black markings; the lightning bolt was yellow, edged with red; and the bomb was black with silver shading.



*The squadron's second insignia was a more stylized designed reflecting its attack mission.*

The CNO approved a change in the squadron's insignia on 7 May 1958. Colors for the black falcon insignia are as follows: a white background outlined in black; the falcon is black with a white eye; the scroll has a white background outlined in black, with black lettering.

Nickname: Black Falcons, 1958–1994.



*The stylized black falcon was used by the squadron for over 35 years before its disestablishment.*

### Chronology of Significant Events

**May 1958:** As part of an Atlantic Fleet training exercise (LANTRAEX 1-58), two of the squadron's AD-6 Skyraiders, flown by Lieutenant (jg)s Strang and Woods, flew nonstop from *Forrestal* (CVA 59), operating off the coast of Jacksonville, Florida, to NAS North Island. The flight was conducted below 1000 feet to demonstrate the low level and long range capability of the squadron. Two days later the aircraft returned, nonstop, to *Forrestal*.

**5 Feb 1963:** The squadron's commanding officer, Commander C. H. Mundt, was killed in an air crash.

**22 Dec 1965:** The squadron's commanding officer, Commander B. J. Cartwright, and his bombardier/navigator, Lieutenant Ed Gold, failed to return from a strike into North Vietnam and are listed as missing in action, presumed dead.

**21 Apr 1966:** The squadron's commanding officer, Commander J. E. Keller, and his bombardier/navigator, Lieutenant Commander E. E. Austin, were killed in action during a mission over North Vietnam.

**27 Apr 1966:** While serving with VA-85 as a bombardier/navigator in an A-6A, Lieutenant (jg) Brian E. Westin was awarded the Navy Cross for heroism during a combat mission over North Vietnam when he risked his own life to save that of his wounded pilot, Lieutenant W. R. Westerman.

**6 Sep 1968:** The squadron's commanding officer, Commander K. L. Coskey, was shot down over North Vietnam. His bombardier/navigator, Lieutenant Commander R. G. McKee, was rescued but Commander Coskey became a POW. He survived the internment at Hanoi and was released on 14 March 1973.

**Jul 1974:** Following a coup that overthrew the government of Cyprus, VA-85 operated from *Forrestal* in the vicinity of Cyprus and provided air cover for the evacuation of Americans and foreign nationals from the island.

**May–Jun 1981:** Following increased military action and Israeli reprisal raids against Syrian missile positions in southern Lebanon, *Forrestal* was ordered to the eastern Mediterranean. VA-85 operated from the carrier while on station off the coast of Lebanon.

**Jul 1982:** Following the Israeli invasion of Lebanon in June and the siege of west Beirut, *Forrestal* operated off

the coast of Lebanon with VA-85 prepared to provide air support for a possible evacuation of Americans.

**Aug–Sep 1982:** *Forrestal* and its embarked squadrons provided air cover for the landing of 800 U.S. Marines in Beirut, Lebanon. The Marines became part of the multi-national peacekeeping force in that country.

**4 Dec 1983:** During *Kennedy's* operations off the coast of Lebanon in support of the Multi-national Peacekeeping Force, several of the carrier's F-14 reconnaissance aircraft received hostile fire from Syrian surface-to-air missile and anti-aircraft positions on 3 December. A retaliatory strike was flown by elements of CVW-3 and aircraft from *Independence* (CV 62) against the Syrian anti-aircraft positions near Hammana, Lebanon. One of the squadron's A-6Es was lost in the attack, its pilot, Lieutenant Mark Lange, was killed and the NFO, Lieutenant Robert Goodman, was captured by the Syrians. He was released 4 January 1985.

**Jul 1984:** The squadron operated in the Caribbean and off the coast of Central America to assist the Coast Guard with drug interdiction operations.

**10 Oct 1985:** The squadron's KA-6D tanker aircraft refueled F-14s from *Saratoga* (CV 60) enroute to their intercept of an Egyptian 737 airliner that was carrying Arab terrorists who had hijacked the Italian cruise ship Achille Lauro on 7 October and murdered an American citizen. The F-14s forced the airliner to land at NAS Sigonella, Sicily, leading to the capture of the terrorists.

**24 Mar 1986:** Libyan missiles were fired at U.S. Naval forces operating in the Gulf of Sidra. This action precipitated a retaliation against Libya by squadrons

from *Saratoga* (CV 60), *America* (CV 66) and *Coral Sea* (CV 43). VA-85's A-6Es conducted a follow-up attack with Rockeye bombs on a Libyan Combattante II G-class fast attack missile craft that had been hit by a Harpoon missile fired by a VA-34 aircraft. The attack resulted in the sinking of the Combattante II. VA-85 aircraft also attacked a Nanuchka II class missile corvette with Rockeyes, damaging the corvette.

**25 Mar 1986:** VA-55 attacked a Nanuchka with Rockeyes, damaging but not stopping the corvette. A VA-85 aircraft then launched a Harpoon against the corvette which resulted in its sinking.

**6 Sep 1989:** Squadron aircraft flew missions in support of the evacuation of personnel from the American Embassy in Beirut, Lebanon, due to the unstable situation in that country.

**17 Jan–28 Feb 1991:** The squadron participated in Operation Desert Storm, combat strikes against targets in Iraq and the Kuwaiti theater of operations. During this period of combat the squadron flew 585 combat sorties, consisting of 1,700 flight hours and expended over 850 tons of ordnance.

**Aug 1993:** Squadron aircraft flew missions over Bosnia-Herzegovina in support of U. N. Operation Deny Flight.

**Nov 1993:** Squadron aircraft flew sorties over Mogadishu, Somalia, in support of U. N. Operation Continue Hope.

**Dec 1993:** Squadron aircraft provided support for reconnaissance missions over southern Iraq, part of Operation Southern Watch.



*A squadron AD-6 Skyraider during its deployment to the Med aboard Lake Champlain (CVA 39) in 1954–1955.*

**Home Port Assignments**

<i>Location</i>	<i>Assignment Date</i>
NAS Niagara Falls	01 Feb 1951
NAS Jacksonville	05 Apr 1951
NAS Quonset Point	26 Sep 1951
NAS Oceana	11 Jun 1952

**Commanding Officers**

	<i>Date Assumed Command</i>
LCDR Richard E. Moot	01 Feb 1951
LCDR Joe W. Williams, Jr.	26 Sep 1952
CDR Adolph Mencin	Mar 1954
CDR Charles H. Jaep III	06 May 1955
CDR Jack C. Heishman	Sep 1956
CDR M. G. Bramilla, Jr.	Sep 1957
CDR E. M. Coppola	05 Sep 1958
CDR Howard C. Lee	25 Mar 1959
CDR William Carrier, Jr.	29 Nov 1960
CDR N. O. Scott, Jr.	Dec 1961
CDR Clinton H. Mundt	21 Dec 1962
CDR John C. McKee	05 Feb 1963
CDR A. H. Barie	Feb 1964
CDR Billie J. Cartwright	15 Apr 1964
CDR J. E. Keller	22 Dec 1965
CDR Ronald J. Hays	21 Apr 1966
CDR J. C. Patterson	20 Jun 1967
CDR Ken L. Coskey	28 Jun 1968
CDR Charles B. Hunter	06 Sep 1968
CDR Herbert A. Hope, Jr.	06 Jun 1969
CDR Donald H. Westbrook	05 Jun 1970
CDR David W. Timberlake	08 May 1971
CDR Michael R. Hall	30 May 1972
CDR Arthur M. Page	01 May 1973
CDR Donald V. Boecker	01 Jul 1974

**Commanding Officers—Continued**

	<i>Date Assumed Command</i>
CDR Richard C. Allen	07 Nov 1975
CDR Charles R. Bubeck	25 Feb 1977
CDR Bruce B. Bremner	May 1978
CDR Ronald J. Zlatoper	26 Jun 1979
CDR Daniel P. Wright	07 Aug 1980
CDR John I. Dow	10 Dec 1981
CDR Kirby E. Hughes II	18 Feb 1983
CDR Paul L. Bernard	17 Aug 1984
CDR Robert W. Day	01 Jul 1985
CDR Robert A. Tolhurst	16 Sep 1986
CDR James B. Stone, Jr.	11 Mar 1988
CDR Dean W. Ellerman, Jr.	05 Jun 1989
CDR Lewis W. Crenshaw, Jr.	16 Aug 1990
CDR Ralph C. Miko	01 Sep 1991
CDR Bruce A. Weber	22 Sep 1992
CDR John W. Scheffler	29 Sep 1993

**Aircraft Assignment**

<i>Type of Aircraft</i>	<i>Date Type First Received</i>
TBM-3E	*
AD-2	05 Mar 1951
AD-4	Jul 1952
AD-6/A-1H‡	Jan 1954†
A-6A	06 Mar 1964
KA-6D	18 Nov 1970
A-6E§	09 Dec 1971

\* During its reserve duty prior to 1 February 1951, the squadron flew the TBM-3E.

† The full complement of AD-6s was not received until May 1954.

‡ The AD-6 designation was changed to A-1H in 1962.

§ VA-85 was the first fleet squadron to receive the A-6E.



*A squadron Skyraider, circa 1963 or 1964.*

**Major Overseas Deployments**

<i>Date of Departure</i>	<i>Date of Return</i>	<i>Air Wing</i>	<i>Carrier</i>	<i>Type of Aircraft</i>	<i>Area of Operation</i>
28 Nov 1951	11 Jun 1952	CVG-8	CV 40	AD-2	Med
26 Apr 1953	21 Oct 1953	CVG-8	CVA 43	AD-4	Med
27 Sep 1954	15 Apr 1955	CVG-8	CVA 39	AD-6	Med
12 Mar 1956	05 Sep 1956	CVG-8	CVA 11	AD-6	Med
28 Jan 1960	31 Aug 1960	CVG-8	CVA 59	AD-6	Med
09 Feb 1961	25 Aug 1961	CVG-8	CVA 59	AD-6	Med
03 Aug 1962	02 Mar 1963	CVG-8	CVA 59	AD-6/A-1H	Med
19 Oct 1965	13 Jun 1966	CVW-11	CVA 63	A-6A	WestPac/Vietnam
05 Nov 1966	19 Jun 1967	CVW-11	CVA 63	A-6A	WestPac/Vietnam
10 Apr 1968	16 Dec 1968	CVW-6	CVA 66	A-6A/B	WestPac/Vietnam
11 Aug 1969	08 May 1970	CVW-14	CVA 64	A-6A/B	WestPac/Vietnam
05 Jan 1971	02 Jul 1971	CVW-17	CVA 59	A-6A & KA-6D	Med
22 Sep 1972	06 Jul 1973	CVW-17	CVA 59	A-6E & KA-6D	Med
11 Mar 1974	11 Sep 1974	CVW-17	CVA 59	A-6E & KA-6D	Med
05 Mar 1975	22 Sep 1975	CVW-17	CV 59	A-6E & KA-6D	Med
04 Apr 1978	26 Oct 1978	CVW-17	CV 59	A-6E & KA-6D	Med/NorLant
27 Nov 1979	07 May 1980	CVW-17	CV 59	A-6E & KA-6D	Med
02 Mar 1981	15 Sep 1981	CVW-17	CV 59	A-6E & KA-6D	Med/NorLant
08 Jun 1982	16 Nov 1982	CVW-17	CV 59	A-6E & KA-6D	Med/IO
25 May 1983	01 Jul 1983	CVW-3	CV 67	A-6E	NorLant
27 Sep 1983	02 May 1984	CVW-3	CV 67	A-6E	SoLant/Med
25 Aug 1985	16 Apr 1986	CVW-17	CV 60	A-6E & KA-6D	Med/IO
05 Jun 1987	17 Nov 1987	CVW-17	CV 60	A-6E & KA-6D	Med
08 Feb 1989	03 Apr 1989	CVW-1	CV 66	A-6E & KA-6D	Carib/NorLant
11 May 1989	10 Nov 1989	CVW-1	CV 66	A-6E & KA-6D	Med/IO
28 Dec 1990	18 Apr 1991	CVW-1	CV 66	A-6E & KA-6D	Med/Red Sea/ Persian Gulf
21 Aug 1991	11 Oct 1991	CVW-1	CV 66	A-6E & KA-6D	NorLant
02 Dec 1991	06 Jun 1992	CVW-1	CV 66	A-6E & KA-6D	Med/Red Sea/ Persian Gulf
11 Aug 1993	05 Feb 1994	CVW-1	CV 66	A-6E	Med

**Air Wing Assignments**

<i>Air Wing</i>	<i>Tail Code</i>	<i>Assignment Date</i>
CVG-8	E/AJ*	05 Apr 1951
CVG-1	AB	19 May 1963
CVG-8/CVW-8†	AJ	25 May 1963
COMFAIRNORFOLK		06 Apr 1964
CVW-11	NH	23 Jul 1965
COMFAIRNORFOLK		12 Aug 1965
CVW-11	NH	23 Sep 1965
COMFAIRNORFOLK		10 Jun 1966
CVW-11	NH	25 Sep 1966
COMFAIRNORFOLK		Jun 1967
CVW-6	AE	01 Oct 1967
CVW-14	NK	01 Apr 1969
COMFAIRNORFOLK		May 1970
CVW-17	AA	01 Aug 1970
CVW-3	AC	01 Jan 1983
CVW-17	AA	31 Dec 1984
CVW-1	AB	01 Jan 1988

\* The tail code was changed from E to AJ in 1957. The effective date for this change was most likely the beginning of FY 58 (1 July 1957).

† CVG-8 was redesignated CVW-8 when Carrier Air Group (CVG) designations were redesignated Carrier Air Wings (CVW) on 20 December 1963.

**Unit Awards Received**

<i>Unit Award</i>	<i>Inclusive Dates Covering Unit Award</i>	
NAVE	01 Jul 1963	30 Jun 1964
	01 Jan 1973	30 Jun 1974
	01 Jul 1975	30 Sep 1976
AFEM	16 Oct 1969	24 Oct 1969
	16 Mar 1970	23 Mar 1970
	06 Nov 1983	27 Nov 1983
	02 Dec 1983	21 Jan 1984
	31 Jan 1984	22 Feb 1984
	25 Feb 1984	29 Feb 1984
MUC	07 Sep 1969	30 Apr 1970

**Unit Awards Received—Continued**

<i>Unit Award</i>	<i>Inclusive Dates Covering Unit Award</i>	
	15 Jul 1982	22 Apr 1984
NEM	20 Jan 1986	29 Mar 1986
NUC	04 Dec 1966	28 Apr 1967
	12 May 1968	20 Nov 1968
	10 Oct 1985	11 Oct 1985
	23 Mar 1986	29 Mar 1986
	17 Jan 1991	07 Feb 1991
RVNGC	15 Jan 1966	19 Jan 1966
	23 Jan 1966	27 Jan 1966
	30 Jan 1966	
	03 Feb 1966	
	07 Mar 1966	
	10 Mar 1966	
	13 Mar 1966	
	22 Apr 1966	
VNSM	25 Nov 1965	23 Dec 1965
	15 Jan 1966	04 Feb 1966
	01 Apr 1966	29 Apr 1966

**Unit Awards Received—Continued**

<i>Unit Award</i>	<i>Inclusive Dates Covering Unit Award</i>	
	08 May 1966	26 May 1966
	08 Dec 1966	03 Jan 1967
	02 Mar 1967	28 Mar 1967
	12 Apr 1967	28 Apr 1967
	08 May 1967	23 May 1967
	29 May 1968	28 Jun 1968
	06 Jul 1968	03 Aug 1968
	17 Aug 1968	12 Sep 1968
	27 Sep 1968	30 Oct 1968
	11 Sep 1969	03 Oct 1969
	01 Nov 1969	23 Nov 1969
	07 Dec 1969	22 Dec 1969
	05 Jan 1970	30 Jan 1970
	12 Feb 1970	01 Mar 1970
	26 Mar 1970	17 Apr 1970
SASM	15 Jan 1991	03 Apr 1991
KLM	17 Jan 1991	28 Feb 1991



*A squadron A-6E Intruder, with CAG markings, landing aboard America (CV 66) in 1993.*

## VA-93

### Lineage

Established as Fighter Squadron NINETY THREE (VF-93) on 26 March 1952.

Redesignated Attack Squadron NINETY THREE (VA-93) on 15 September 1956.

Disestablished on 31 August 1986. The first squadron to be assigned the VA-93 designation.

### Squadron Insignia and Nickname

The squadron's first insignia was approved by CNO on 14 April 1954. Colors for the flying tiger shark



*The flying tiger shark was the squadron's first insignia.*

Following the squadron's redesignation a new insignia was approved by CNO on 8 May 1957. The skull and stylized aircraft insignia colors were: a dark blue background; white clouds outlined in black; black skull with white highlights and red eyes; yellow lightning bolts outlined in black; silver gray aircraft outlined in

insignia were: a background of light blue with a buzz saw outline in red; the upper part of the shark was dark blue, the lower part white and the shark was outlined in black; gold wings with a white eye and red pupil; the carrier was gray outlined in black with white streaks running from the carrier to the tail of the shark.



*The skull and stylized aircraft insignia was adopted by the squadron in 1957.*

black and red contrails outlined in black; a white scroll outlined in black with black letters.

A new insignia was approved by CNO on 19 November 1965. Insignia colors for the stylized aircraft with a series of circles were: a dark blue outer circle followed by a medium blue circle, then a light



*The stylized aircraft design was the last insignia used by the squadron.*

blue circle and a white center; the stylized aircraft were dark blue with red contrails; the scroll had a white background outlined in black, with black lettering.

Nickname: Blue Blazers, 1954–1976.

Ravens, 1976–1986.

### Chronology of Significant Events

**May 1963:** Following the military losses of the Lao neutralist to the Pathet Lao in the Plaine de Jarres, Laos, *Ranger* (CVA 61) transited to the South China Sea to support possible operations in Laos.

**15 Oct 1963:** The squadron established a Detachment Q for deployment aboard the anti-submarine carrier *Bennington* (CVS 20) to provide daylight fighter protection for the ASW aircraft. The detachment flew A-4B Skyhawks.

**7 Feb 1965:** Following a Viet Cong attack against the American advisors compound at Pleiku, South Vietnam, a reprisal strike, named Flaming Dart I, was ordered by the President. VA-93 participated in this strike, but upon reaching the target, the military barracks at Vit Thu Lu, the mission was aborted due to the weather.

**11 Feb 1965:** Participated in Flaming Dart II, retaliatory strikes against the military barracks at Chanh Hoa, North Vietnam.

**15 Mar 1965:** Participated in Rolling Thunder strikes against ammunition storage area in Phu Qui, North Vietnam.

**May–Oct 1972:** Participated in Operation Linebacker I, heavy air strikes against targets in North Vietnam to reduce that country's ability to continue the war effort in South Vietnam.

**Apr 1975:** Participated in Operation Frequent Wind, the evacuation of American personnel from Saigon, South Vietnam as the country fell to the communists.

**Aug–Sep 1976:** Operated near the Korea Peninsula following the murder of U.S. military personnel in the Korean DMZ by North Koreans.

**Nov–Dec 1979:** In response to the seizure of the American Embassy and its staff, by an Iranian mob, and the Soviet invasion of Afghanistan, *Midway* (CV 41) operated in the Arabian Sea.

**May–Jun 1980:** Following the massacre of several hundred people in the city of Kwangju, South Korea, *Midway* operated off the coast of South Korea until the crisis had subsided.

**Dec 1981:** Following unrest in Korea, *Midway* operated off the coast of South Korea for several days.



**Home Port Assignment**

<i>Location</i>	<i>Assignment Date</i>
NAS Alameda	26 Mar 1952
NAS Lemoore	08 Mar 1962
NS Yokosuka (NAF Atsugi & Misawa)*	05 Oct 1973*
NAS Lemoore	16 Apr 1986

\* VA-93, along with CVW-5 and *Midway* (CVA 41), were part of a program to permanently assign a carrier and air wing to an overseas home port. *Midway's* new home port was NS Yokosuka, Japan, and the squadron would normally operate out of NAF Atsugi or Misawa when the carrier was at NS Yokosuka. The assignment was effective 30 June 1973. However, the squadron did not arrive until 5 October 1973.

**Commanding Officers**

	<i>Date Assumed Command</i>
LCDR E. W. Smith (acting)	26 Mar 1952
LCDR W. E. Carver	23 Apr 1952
LCDR J. T. Barker	May 1953
CDR G. E. Hartley	Jul 1955
CDR Paul E. Padget	24 Sep 1956
CDR Robert F. Kanze	30 Apr 1958
CDR E. W. Gendron	27 May 1959
CDR William H. Hile, Jr.	21 Jul 1960
CDR J. W. Porter, Jr.	09 Jun 1961
CDR Robert F. Schoultz	27 Mar 1962

**Commanding Officers—Continued**

	<i>Date Assumed Command</i>
CDR William M. Gortney	02 Mar 1963
CDR E. W. O'Callaghan	05 Feb 1964
CDR A. J. Monger	11 Jan 1965
CDR W. G. Sizemore	04 Jan 1966
CDR R. S. Salin	Jan 1967
CDR R. R. Wilson	17 Jan 1968
CDR Thomas W. Schaaf	10 Jul 1968
CDR David L. Glunt, Jr.	19 Jan 1970
CDR Edwin R. Kohn, Jr.	19 Nov 1970
CDR Carl E. Erie	22 Jul 1971
CDR Jerry L. Terrell	13 Jul 1972
CDR Douglas L. Clarke	29 Jan 1973
CDR Walter V. Roeser	10 May 1974
CDR William A. Dougherty, Jr.	06 Jun 1975
CDR Rodger W. Wright	18 Sep 1976
CDR John W. Patterson	3 Jan 1977
CDR Clarence S. Vaught	30 Mar 1978
CDR Eugene F. Mitchell	22 Jun 1979
CDR Marion R. Rackowitz	22 Oct 1980
CDR James H. Finney	21 Dec 1981
CDR Dennis W. Ireland	11 May 1982
CDR Harry W. Hartsell	04 Oct 1984
CDR David V. Park*	15 Jun 1986

\* Commander Park assumed the duties of VA-93 as Officer in Charge, not Commanding Officer.



*A squadron F9F-8 Cougar flies along side a VC-61 Det M F9F-8 during deployment to WestPac in 1956 aboard Oriskany (CVA 34).*

**Aircraft Assignment**

<i>Type of Aircraft</i>	<i>Date Type First Received</i>
FG-1D	May 1952
F9F-2	May 1952
F9F-5	Sep 1953
F9F-8	Jan 1955
A4D-1	26 Nov 1956
A4D-2	25 May 1958
A4D-2N/A-4C*	01 Sep 1960

**Aircraft Assignment—Continued**

<i>Type of Aircraft</i>	<i>Date Type First Received</i>
A-4B	15 Oct 1963
A-4E	Sep 1966
A-4F	Sep 1967
A-7B	20 Apr 1969
A-7A	Mar 1973
A-7E	Apr 1977

\* The A4D-2N designation was changed to A-4C in 1962.

**Major Overseas Deployments**

<i>Date of Departure</i>	<i>Date of Return</i>	<i>Air Wing</i>	<i>Carrier</i>	<i>Type of Aircraft</i>	<i>Area of Operation</i>
15 Dec 1952	14 Aug 1953	CVG-9	CVA 47	F9F-2	Korea
11 May 1954	12 Dec 1954	CVG-9	CVA 12	F9F-5	World Cruise
11 Feb 1956	13 Jun 1956	CVG-9	CVA 34	F9F-8	WestPac
16 Sep 1957	25 Apr 1958	CVG-9	CVA 14	A4D-1	WestPac
06 Feb 1960	30 Aug 1960	CVG-9	CVA 61	A4D-2	WestPac
11 Aug 1961	08 Mar 1962	CVG-9	CVA 61	A4D-2N	WestPac
09 Nov 1962	14 Jun 1963	CVG-9	CVA 61	A-4C	WestPac
05 Aug 1964	06 May 1965	CVW-9	CVA 61	A-4C	WestPac/Vietnam
26 Oct 1965	21 Jun 1966	CVW-9	CVAN 65	A-4C	WestPac/Vietnam
05 Jan 1967	22 Jul 1967	CVW-5	CVA 19	A-4E	WestPac/Vietnam
27 Jan 1968	10 Oct 1968	CVW-5	CVA 31	A-4F	WestPac/Vietnam
14 Oct 1969	01 Jun 1970	CVW-2	CVA 61	A-7B	WestPac/Vietnam
16 Apr 1971	06 Nov 1971	CVW-5	CVA 41	A-7B	WestPac/Vietnam
10 Apr 1972	03 Mar 1973	CVW-5	CVA 41	A-7B	WestPac/Vietnam
11 Sep 1973	05 Oct 1973	CVW-5	CVA 41	A-7A	WestPac*
26 Nov 1973	22 Dec 1973	CVW-5	CVA 41	A-7A	WestPac
29 Jan 1974	06 Mar 1974	CVW-5	CVA 41	A-7A	WestPac
18 Oct 1974	20 Dec 1974	CVW-5	CVA 41	A-7A	WestPac
13 Jan 1975	18 Feb 1975	CVW-5	CVA 41	A-7A	WestPac
31 Mar 1975	29 May 1975	CVW-5	CVA 41	A-7A	WestPac
04 Oct 1975	19 Dec 1975	CVW-5	CV 41	A-7A	WestPac/IO
13 Mar 1976	26 Apr 1976	CVW-5	CV 41	A-7A	WestPac
19 May 1976	22 Jun 1976	CVW-5	CV 41	A-7A	WestPac
09 Jul 1976	04 Aug 1976	CVW-5	CV 41	A-7A	WestPac
01 Nov 1976	17 Dec 1976	CVW-5	CV 41	A-7A	WestPac
11 Jan 1977	01 Mar 1977	CVW-5	CV 41	A-7A	WestPac
19 Apr 1977	25 Apr 1977	CVW-5	CV 41	A-7A	WestPac†
18 Aug 1977	02 Sep 1977	CVW-5	CV 41	A-7E	WestPac
27 Sep 1977	21 Dec 1977	CVW-5	CV 41	A-7E	WestPac/IO
11 Apr 1978	23 May 1978	CVW-5	CV 41	A-7E	WestPac
09 Nov 1978	23 Dec 1978	CVW-5	CV 41	A-7E	WestPac
11 Jan 1979	20 Feb 1979	CVW-5	CV 41	A-7E	WestPac
07 Apr 1979	18 Jun 1979	CVW-5	CV 41	A-7E	IO
20 Aug 1979	14 Sep 1979	CVW-5	CV 41	A-7E	WestPac
30 Sep 1979	20 Feb 1980	CVW-5	CV 41	A-7E	IO
14 Jul 1980	26 Nov 1980	CVW-5	CV 41	A-7E	WestPac/IO
23 Feb 1981	05 Jun 1981	CVW-5	CV 41	A-7E	WestPac/IO
26 Jun 1981	16 Jul 1981	CVW-5	CV 41	A-7E	WestPac
03 Sep 1981	06 Oct 1981	CVW-5	CV 41	A-7E	WestPac
26 Apr 1982	18 Jun 1982	CVW-5	CV 41	A-7E	WestPac
14 Sep 1982	11 Dec 1982	CVW-5	CV 41	A-7E	NorPac/WestPac
02 Jun 1983	14 Aug 1983	CVW-5	CV 41	A-7E	WestPac

**Major Overseas Deployments—Continued**

<i>Date of Departure</i>	<i>Date of Return</i>	<i>Air Wing</i>	<i>Carrier</i>	<i>Type of Aircraft</i>	<i>Area of Operation</i>
25 Oct 1983	11 Dec 1983	CVW-5	CV 41	A-7E	WestPac
28 Dec 1983	23 May 1984	CVW-5	CV 41	A-7E	IO
15 Oct 1984	12 Dec 1984	CVW-5	CV 41	A-7E	WestPac
01 Feb 1985	28 Mar 1985	CVW-5	CV 41	A-7E	WestPac
10 Jun 1985	14 Oct 1985	CVW-5	CV 41	A-7E	IO/WestPac
15 Nov 1985	12 Dec 1985	CVW-5	CV 41	A-7E	WestPac
17 Jan 1986	30 Mar 1986	CVW-5	CV 41	A-7E	WestPac

\* *Midway* (CVA 41) with CVW-5 and its assigned squadrons, including VA-93, were forward deployed and home ported overseas at NS Yokosuka, Japan. Only operations outside the home waters of Japan are listed as deployments.

† During the period 25 April to 17 August 1977, VA-93 was shore based at NAS Cubi Point, Philippines, transitioning from the A-7A to the A-7E.



A squadron A-4E Skyhawk aboard Hancock (CVA 19) during their 1967 combat cruise to Vietnam. Notice the stylized aircraft on the fuselage aft of the jet intake.

**Air Wing Assignments**

<i>Air Wing</i>	<i>Tail Code</i>	<i>Assignment Date</i>
CVG-9/CVW-9†	N/NG*	Mar 1952
CVW-5	NF	01 Aug 1966
COMFAIRALAMEDA		01 Nov 1968
CVW-2	NE	19 May 1969
COMFAIRLEMOORE		01 Jun 1970
CVW-16	AH	01 Sep 1970
CVW-5	NF	16 Feb 1971

\* The tail code was changed from N to NG in 1957. The effective date for this change was most likely the beginning of FY 58 (1 July 1957).

† CVG-9 was redesignated CVW-9 when Carrier Air Group (CVG) designations were redesignated Carrier Air Wings (CVW) on 20 December 1963.

**Unit Awards Received**

<i>Unit Award</i>	<i>Inclusive Dates Covering Unit Award</i>	
KPUC	25 Jan 1953	27 Jul 1953
NUC	31 Jan 1953	27 Jul 1953
	29 Apr 1975	30 Apr 1975
	01 Jan 1978	30 Jun 1979
MUC	27 Oct 1969	12 May 1970
	07 May 1971	28 Oct 1971
	13 Nov 1979	08 Feb 1980
	27 Jul 1982	01 May 1984
NAVE	01 Jul 1962	30 Jun 1963
	01 Jan 1970	30 Jun 1971
	01 Jan 1982	30 Jun 1983
AFEM	24 Jun 1960	25 Jun 1960
	01 May 1963	05 May 1963

**Unit Awards Received—Continued**

<i>Unit Award</i>	<i>Inclusive Dates Covering Unit Award</i>	
	19 Sep 1964	20 Sep 1964
	01 Oct 1964	09 Oct 1964
	28 Nov 1964	30 Dec 1964
	17 Jan 1965	17 Mar 1965
	04 Apr 1965	13 Apr 1965
	04 May 1968	07 May 1968
	10 Jan 1970	13 Jan 1970
	12 Apr 1970	13 Apr 1970
	29 Apr 1975	30 Apr 1975
HSM	29 Apr 1975	30 Apr 1975
NEM	15 Apr 1979	06 Jun 1979
	21 Nov 1979	07 Feb 1980
	19 Aug 1980	13 Nov 1980
	12 Mar 1981	19 May 1981
PUC	30 Apr 1972	09 Feb 1973
RVNGC	30 Mar 1972	15 Jul 1972
VNSM	02 Dec 1965	14 Jan 1966
	04 Feb 1966	23 Feb 1966
	16 Mar 1966	12 Apr 1966
	22 Apr 1966	14 May 1966
	23 May 1966	06 Jun 1966
	05 Feb 1967	25 Feb 1967
	15 Mar 1967	12 Apr 1967
	28 Apr 1967	04 Jun 1967

**Unit Awards Received—Continued**

<i>Unit Award</i>	<i>Inclusive Dates Covering Unit Award</i>	
	12 Jun 1967	27 Jun 1967
	20 Feb 1968	24 Mar 1968
	13 Jun 1968	07 Jul 1968
	21 Jul 1968	18 Aug 1968
	27 Aug 1968	14 Sep 1968
	16 Nov 1969	07 Dec 1969
	17 Dec 1969	06 Jan 1970
	29 Jan 1970	18 Feb 1970
	27 Feb 1970	30 Mar 1970
	16 Apr 1970	13 May 1970
	17 May 1971	09 Jun 1971
	29 Jun 1971	20 Jul 1971
	31 Jul 1971	17 Aug 1971
	26 Sep 1971	11 Oct 1971
	01 May 1972	01 Jun 1972
	11 Jun 1972	07 Jul 1972
	16 Jul 1972	13 Aug 1972
	23 Aug 1972	10 Sep 1972
	19 Sep 1972	12 Oct 1972
	23 Oct 1972	23 Nov 1972
	03 Dec 1972	22 Dec 1972
	31 Dec 1972	
	04 Jan 1973	24 Jan 1973
	03 Feb 1973	09 Feb 1973



*A flight of squadron A-7B Corsair IIs in 1969.*

## VA-94

### Lineage

Established as Bombing Squadron NINETY NINE (VB-99) on 1 July 1943.

Redesignated Bombing Squadron TWENTY (VB-20) on 15 October 1943.

Redesignated Attack Squadron NINE A (VA-9A) on 15 November 1946.

Redesignated Attack Squadron NINETY FOUR (VA-94) on 12 August 1948.

Disestablished on 30 November 1949. The first squadron to be assigned the VA-94 designation.

### Squadron Insignia and Nickname

The squadron insignia was approved by CNO on 9 December 1943. Colors for the cat and skull insignia



The squadron insignia was approved for use in December 1943.

were: light blue background with white border and dark blue outline; the cat was black and white with green eyes; the skull was shaded white and green with black outlines and shadows; helmet was mustard yellow, goggles were brown with white shading, the glasses were green and black; and a yellow bomb with brown and white shading.

Nickname: Bombing Twenty's Tough Kitty, 1943–1946.

### Chronology of Significant Events

**Jul-Oct 1943:** VB-99 was established as an experimental squadron for the new SB2C aircraft until its redesignation as VB-20 and assignment to CVG-20.

**31 Aug 1944:** The squadron's first combat action involved an attack on the Bonin Islands.

**Sep 1944:** The squadron participated in pre-invasion strikes on Palau Islands and provided air support for landings on Peleliu Island.

**Oct 1944:** Squadron aircraft participated in air strikes against Okinawa, Formosa and Luzon.

**24 Oct 1944:** The squadron participated in the Battle for Leyte Gulf. VB-20's SB2Cs flew sorties against a powerful Japanese surface force in the Sibuyan Sea. These attacks contributed to the sinking of the *Musashi*, one of the two largest battleships in the world. The following squadron personnel were awarded the Navy Cross for this action: Ensigns M. E. Adams, R. J. Barnes, H. A. Koster, R. D. Olson, M. T.

Ross, and D. D. J. Spanagel; Lieutenant (jg)s P. P. Cook, J. M. Glynn, R. D. Reed, J. P. Trytten, and J. E. Tsarnas; Lieutenants W. N. Christensen, J. S. Cooper, H. C. Hogan, R. E. Moore, R. D. Warner and R. S. Wilcox; and Commander R. E. Riera.

**25 Oct 1944:** Squadron aircraft were part of the Fast Carrier Task Force that attacked the Japanese carrier force in the Battle of Cape Engano. Four Japanese carriers were sunk during this engagement. The following squadron personnel were awarded the Navy Cross for their actions during the Battle of Cape Engano: Ensigns H. C. Bearden, D. F. Hughes, C. Z. Stevens III, and W. P. Wright; Lieutenant (jg) W. C. Phtilla; Lieutenants W. W. Anderson, C. Burkhart and L. C. Flynt; and Commander R. E. Riera.

**Nov 1944:** Squadron aircraft flew strikes against a Japanese troop convoy in Ormoc Bay, Leyte and enemy positions on Luzon.

**Dec 1944:** The squadron participated in strikes flown against Luzon.

**Jan 1945:** Squadron aircraft flew strikes against Luzon, Formosa, Hong Kong, and Japanese convoys in South China Sea and Okinawa.

**12 Jan 1945:** The following squadron personnel were awarded the Silver Star medal for action against a Japanese cruiser protecting a convoy of cargo ships: Lieutenants W. N. Christensen and W. W. Anderson and Lieutenant (jg) H. Rubner.

### Home Port Assignment

Location	Assignment Date
NAS San Diego	01 Jul 1943
NAS Kaneohe	21 Apr 1944*
NAS Barbers Point	30 Apr 1944*
NAS Puunene	17 Jun 1944*
NAS San Diego	23 Feb 1945
NAS Wildwood	16 Apr 1945
NAS Edenton	22 Jun 1945
NAAS Elizabeth City	01 Nov 1945
NAAS Charlestown	01 Mar 1946

\* Temporary shore assignment while the squadron conducted training in preparation for combat deployment.

### Commanding Officers

	Date Assumed Command
LCDR Louis J. Kirn	Jul 1943
LCDR Robert E. Riera	10 Nov 1943
LCDR Raymond E. Moore	10 Nov 1944
LT James S. Cooper (acting)	16 Apr 1945
LT James S. Cooper	19 Apr 1945
LCDR Lawrence G. Traynor	05 Jun 1947
LCDR Harlin M. Keister	06 Jul 1948

**Aircraft Assignment**

<i>Type of Aircraft</i>	<i>Date Type First Received</i>
SBD-5	Jul 1943
SB2C-1C	15 Nov 1943
SB2C-3	Jul 1944
SB2C-4E	18 Apr 1945

**Aircraft Assignment—Continued**

<i>Type of Aircraft</i>	<i>Date Type First Received</i>
SBW-5	04 Aug 1945
SB2C-5	Mar 1946
AD-2	04 Oct 1948

**Major Overseas Deployments**

<i>Date of Departure</i>	<i>Date of Return</i>	<i>Air Wing</i>	<i>Carrier</i>	<i>Type of Aircraft</i>	<i>Area of Operation</i>
16 Aug 1944	23 Nov 1944	CVG-20	CV 6*	SB2C-3	Pacific
23 Nov 1944	02 Feb 1945	CVG-20	CV 16**	SB2C-3	Pacific
09 Feb 1948	26 Jun 1948	CVAG-9	CV 47	SB2C-5	Carib/Med

\* The squadron transferred from *Enterprise* (CV 6) to *Lexington* (CV 16) and remained deployed in the Pacific.

\*\* The squadron completed its combat tour in the Pacific and transferred from *Lexington* (CV 16) to *Kwajalein* (CVE 98) for transportation back to the United States.

**Air Wing Assignments**

<i>Air Wing</i>	<i>Tail Code</i>	<i>Assignment Date</i>
CVG-20/CVAG-9/CVG-9*	PS/D**	15 Oct 1943

\* Established as CVG-20 on 15 October 1943. Redesignated CVAG-9 on 15 November 1946. CVAG-9 redesignated CVG-9 on 1 September 1948. CVG-9 was disestablished on 1 December 1949.

\*\* The tail code PS was assigned to *Philippine Sea* (CV 47) and CVG-9 in 1946. In 1948 the tail code for CVG-9 was changed to D.

**Unit Awards Received**

<i>Unit Award</i>	<i>Inclusive Dates Covering Unit Award</i>	
NUC	31 Aug 1944	18 Sep 1944
	10 Oct 1944	22 Nov 1944
PUC	14 Dec 1944	16 Dec 1944
	03 Jan 1945	22 Jan 1945
Campaign Medal (Asiatic-Pacific)	31 Aug 1944	18 Sep 1944
	10 Oct 1944	22 Nov 1944
	14 Dec 1944	16 Dec 1944
	03 Jan 1945	22 Jan 1945



*A flight of squadron SB2C-5 Helldivers during deployment to the Med in 1948 aboard Philippine Sea (CV 47).*

## VA-95

### Lineage

Established as Torpedo Squadron TWENTY (VT-20) on 15 October 1943.

Redesignated Attack Squadron TEN A (VA-10A) on 15 November 1946.

Redesignated Attack Squadron NINETY FIVE (VA-95) on 12 August 1948.

Disestablished on 30 November 1949. The first squadron to be designated VA-95.

### Squadron Insignia and Nickname

The squadron's insignia was approved by CNO on 21 March 1944. Colors for the vulture insignia were:



*The squadron insignia was approved in March 1944.*

background of light blue with an inner circle of white and a black outer circle; the bird was pearl gray with white highlights and outlined in black; the leg and ruff of feathers around the neck were white with blue markings; the head, neck and feet a drab yellow, and the beak was black; the torpedo had shades of gray with a white, black

and yellow streak, the nose was black and the torpedo was outlined in black; streaks emanating from the nose of the torpedo were blue and white.

Nickname: unknown.

### Chronology of Significant Events

**1 Sep 1944:** The squadron's first combat action involved strikes against shore installations on Chichi Jima in the Bonin Islands.

**Sep 1944:** Squadron aircraft participated in strikes against Palau Islands in preparation for and support of the landings on Peleliu Island.

**Oct 1944:** The squadron participated in strikes against Okinawa, Formosa and Luzon in preparation for and support of the landings on Leyte.

**15 Oct 1944:** Lieutenant Edward B. Holley, flying a squadron TBM, shot down a Zero, Mitsubishi A6M fighter, over Luzon.

**24 Oct 1944:** The squadron participated in the Battle for Leyte Gulf. VT-20's TBM-1Cs flew sorties against a powerful Japanese surface force in the Sibuyan Sea. These attacks contributed to the sinking of the mighty *Musashi*, one of the two largest battleships in the world. The following squadron personnel were award-

ed the Navy Cross for their action against the Japanese task force: Ensigns W. T. Ross, W. J. Schaller, and G. Swint III; Lieutenant (jg) M. Throwbridge; Lieutenants C. H. H. Dickey, E. B. Holley, and R. E. McHenry, and Lieutenant Commander S. L. Prickett.

**25 Oct 1944:** Squadron aircraft were part of the Fast Carrier Task Force that attacked the Japanese carrier force in the Battle of Cape Engano. Four Japanese carriers were sunk during this engagement. The following squadron personnel were awarded the Navy Cross for their action during the Battle of Cape Engano: Ensigns T. E. Armour, J. L. Baxter, M. H. Krouse, and C. D. Leeper; Lieutenant (jg)s P. H. Bradley and C. F. Schlegel; and Lieutenants J. H. Howell, Jr., M. L. Leedom, E. E. Rodenburg, and R. J. Savage.

**Nov 1944:** The squadron participated in strikes against a Japanese troop convoy in Ormoc Bay, Leyte and enemy positions on Luzon.

**Dec 1944:** Strikes were flown against Luzon in preparation for the landings at Lingayan Gulf, Luzon.

**Jan 1945:** Squadron aircraft flew strikes against Luzon, Formosa, Hong Kong, Japanese convoys in South China Sea and along coast of French Indochina, and Okinawa.

**12 Jan 1945:** Lieutenant J. N. Howell, Jr and Lieutenant (jg) M. Throwbridge were awarded the Silver Star Medal for their action against a Japanese cruiser that was protecting a convoy off the coast of French Indochina. Their attacks contributed to the sinking of the cruiser.

### Home Port Assignments

<i>Location</i>	<i>Assignment Date</i>
NAS San Diego	15 Oct 1943
NAS Barbers Point	21 Apr 1944*
NAS Puunene	17 Jun 1944*
NAS San Diego	23 Feb 1945
NAAF Lewiston	16 Apr 1945
NAS Edenton	Jun 1945
NAAS Elizabeth City	02 Nov 1945
NAAS Charlestown	21 Mar 1946

\* Temporary shore assignment while the squadron conducted training in preparation for combat deployment.

### Commanding Officers

	<i>Date Assumed Command</i>
LCDR David E. Dressendorfer	15 Oct 1943
LCDR Samuel L. Prickett	27 Dec 1943
LCDR James N. Howell, Jr.	16 Apr 1945
LCDR J. J. Maechtlen	Jul 1947
LCDR Charles C. Ainsworth	07 Feb 1949

**Aircraft Assignment**

<i>Type of Aircraft</i>	<i>Date Type First Received</i>
TBF-1/TBM-1	Nov 1943
TBM-1C	Feb 1944

**Aircraft Assignment**

<i>Type of Aircraft</i>	<i>Date Type First Received</i>
TBM-3E	Jul 1945
AD-1	01 Aug 1949

**Major Overseas Deployments**

<i>Date of Departure</i>	<i>Date of Return</i>	<i>Air Wing</i>	<i>Carrier</i>	<i>Type of Aircraft</i>	<i>Area of Operation</i>
16 Aug 1944	23 Nov 1944	CVG-20	CV 6*	TBM-1C	Pacific
23 Nov 1944	02 Feb 1945	CVG-20	CV 16†	TBM-1C	Pacific
09 Feb 1948	26 Jun 1948	CVAG-9	CV 47	TBM-3E	Carib/Med

**Air Wing Assignments**

<i>Air Wing</i>	<i>Tail Code</i>	<i>Assignment Date</i>
CVG-20/CVAG-9/ CVG-9*	PS/D†	15 Oct 1943

\* Established as CVG-20 on 15 October 1943. Redesignated CVAG-9 on 15 November 1946. CVAG-9 redesignated CVG-9 on 1 September 1948. CVG-9 was disestablished on 1 December 1949.

† The tail code PS was assigned to *Philippine Sea* (CV 47) and CVG-9 in 1946. In 1948 the tail code for CVG-9 was changed to D.

**Unit Awards Received**

<i>Unit Award</i>	<i>Inclusive Dates Covering Unit Award</i>	
NUC	31 Aug 1944	18 Sep 1944
	10 Oct 1944	22 Nov 1944
PUC	14 Dec 1944	16 Dec 1944
	03 Jan 1945	22 Jan 1945
Campaign Medal (Asiatic-Pacific)	31 Aug 1944	18 Sep 1944
	10 Oct 1944	22 Nov 1944
	14 Dec 1944	16 Dec 1944
	03 Jan 1945	22 Jan 1945



A squadron TBM-1C aboard *Enterprise* (CV 6) in October 1944. Note the damage on the wing of the aircraft (Courtesy David Laucabaugh Collection).



## SECOND VA-95

### Lineage

Established as Attack Squadron NINETY FIVE (VA-95) on 26 March 1952.

Disestablished on 1 April 1970. The second squadron to be assigned the VA-95 designation.

### Squadron Insignia and Nickname

The squadron's insignia was approved by CNO on 16 January 1957. Colors for the knight plumed helmet were: black background on left hand side and silver on the right half of the circular design, with a silver outline on the left and a black outline on the right; silver mace and black sword; the left side of the helmet was silver with green and black markings; the right side of the helmet was green with silver markings;



The squadron's plumed helmet insignia was approved in 1957.

the plume was red; and the scroll was silver, outlined in black with green lettering.

Nickname: Skyknights, 1957–1963.

Green Lizards, 1963–1970.

### Chronology of Significant Events

**Jan 1963:** The squadron participated in cross deck operations with the British carrier HMS *Hermes* while operating in the western Pacific.

**May 1963:** Following the military losses of Lao neutralists to the Pathet Lao in the Plaine de Jarres, Laos, *Ranger* (CVA 61) transited to the South China Sea to support possible operations in Laos.

**Nov 1964–Apr 1965:** The squadron participated in support for photo reconnaissance missions and conducted strikes against targets in Laos.

**7 Feb 1965:** Following a Viet Cong attack against the American advisors compound at Pleiku, South Vietnam, the President ordered a reprisal strike against North Vietnam, named Flaming Dart I. The squadron's target was the Vit Thu Lu Barracks. However, the strike turned back due to poor weather conditions.

**11 Feb 1965:** Squadron aircraft participated in Flaming Dart II, retaliatory strikes against the Chanh Hoa military barracks near Dong Hoi, North Vietnam.

**Mar 1965:** The squadron participated in Rolling Thunder strikes against the Phu Qui ammunition depot in North Vietnam.

**Apr 1966:** The squadron departed Norfolk, Virginia,

enroute to Vietnam as part of an air wing composed only of attack squadrons.

**Sep 1969:** Following a coup that overthrew the Libyan monarchy *Kennedy* (CVA 67) cut short its visit to Cannes, France, and departed for operations in the Ionian Sea. The United States later extended diplomatic recognition to the new Libyan government.

### Home Port Assignments

	<i>Location Assignment Date</i>
NAS Alameda	26 Mar 1952
NAS Moffett Field	08 Mar 1962
NAS Lemoore	01 Apr 1963
NAS Alameda	04 Aug 1968

### Commanding Officers

	<i>Date Assumed Command</i>
LCDR Samuel B. Berrey	26 Mar 1952
LT L. Wilson (acting)	1953
CDR David L. Berrey	Aug 1953
CDR John C. Allman	Oct 1954
CDR Donald L. Irgens	Jan 1955
CDR Martin J. Stack	Sep 1956
CDR F. L. Brady	21 Mar 1958
CDR Rollin E. Gray, Jr.	20 Apr 1958
CDR Carl Weisse	04 Mar 1959
CDR R. R. Renaldi	02 Sep 1960
CDR Stanley F. Abele	13 Jun 1961
CDR H. G. Silliman	17 Jul 1962
CDR Harold J. Zenner	19 Jul 1963
CDR Dwight E. DeCamp	05 Jun 1964
CDR G. E. Jacobssen, Jr.	15 Jun 1965
CDR F. E. O'Connor, Jr.	10 Jun 1966
CDR W. E. Ohlrich, Jr.	26 Jun 1967
CDR M. A. Benero, Jr.	1968
CDR J. K. Hassett	02 Jul 1969

### Aircraft Assignment

<i>Type of Aircraft</i>	<i>Date Type First Received</i>
F6F-5	21 Apr 1952
AD-1	19 May 1952
AD-4NA	03 Jul 1952
AD-4	Sep 1952
AD-4L	Oct 1952
AD-6/A-1H*	Oct 1953
AD-7/A-1J*	Sep 1956
A-4C	15 Jul 1965
A-4B	05 Dec 1965
A-4C	Sep 1968

\* The AD-6 and AD-7 designations were changed to A-1H and A-1J in 1962.



A squadron AD-6 Skyraider positioned on the forward part of the flight deck along with other air wing Skyraiders. The photo was taken during Hornet's (CVA 12) transit through the Suez Canal in June 1954 during her world cruise.

### Major Overseas Deployments

<i>Date of Departure</i>	<i>Date of Return</i>	<i>Air Wing</i>	<i>Carrier</i>	<i>Type of Aircraft</i>	<i>Area of Operation</i>
15 Dec 1952	14 Aug 1953	CVG-9	CVA 47	AD-4/L/NA	Korea
11 May 1954	12 Dec 1954	CVG-9	CVA 12	AD-6	World Cruise
11 Feb 1956	13 Jun 1956	CVG-9	CVA 34	AD-6	WestPac
16 Sep 1957	25 Apr 1958	CVG-9	CVA 14	AD-7	WestPac
06 Feb 1960	30 Aug 1960	CVG-9	CVA 61	AD-7	WestPac
11 Aug 1961	08 Mar 1962	CVG-9	CVA 61	AD-7	WestPac
09 Nov 1962	14 Jun 1963	CVG-9	CVA 61	AD-6/7	WestPac
05 Aug 1964	06 May 1965	CVW-9	CVA 61	A-1H/J	WestPac/Vietnam
04 Apr 1966	21 Nov 1966	CVW-10	CVS 11	A-4B	WestPac/Vietnam
15 Nov 1967	04 Aug 1968	CVW-8	CVA 38	A-4B	Med
05 Apr 1969	21 Dec 1969	CVW-1	CVA 67	A-4C	Med

**Air Wing Assignments**

<i>Air Wing</i>	<i>Tail Code</i>	<i>Assignment Date</i>
CVG-9/CVW-9†	N/NG*	26 Mar 1952
COMFAIRALAMEDA		02 Oct 1965
CVW-10	AK	01 Feb 1966
CVW-8	AJ	Oct 1967
COMFAIRALAMEDA		26 Aug 1968
CVW-1	AB	Feb 1969
COMFAIRALAMEDA		02 Mar 1970

\* The tail code was changed from N to NG in 1957. The effective date for this change was most likely the beginning of FY 58 (1 July 1957).

† CVG-9 was redesignated CVW-9 when Carrier Air Group (CVG) designations were redesignated Carrier Air Wings (CVW) on 20 December 1963.

**Unit Awards Received**

<i>Unit Award</i>	<i>Inclusive Dates Covering Unit Award</i>	
KPUC	25 Jan 1953	27 Jul 1953
NUC	31 Jan 1953	27 Jul 1953
AFEM	19 Sep 1964	20 Sep 1964
	01 Oct 1964	09 Oct 1964
	28 Nov 1964	30 Dec 1964
	17 Jan 1965	17 Mar 1965
	04 Apr 1965	13 Apr 1965
VNSM	15 May 1966	15 Jun 1966
	08 Jul 1966	10 Aug 1966
	01 Sep 1966	23 Sep 1966
	02 Oct 1966	18 Oct 1966



All 14 of the squadron's A-4B Skyhawks are parked in numerical order on the flight line in 1967.

## THIRD VA-95

### Lineage

Established as Attack Squadron NINETY FIVE (VA-95) on 1 April 1972. The third squadron to be assigned the VA-95 designation.

### Squadron Insignia and Nickname

The squadron's insignia was approved by CNO on 25 July 1972. Colors for the green lizard insignia are as follows: a white scroll with black letters and a black outline of the insignia and scroll; background of the lower half is dark blue with black and yellow markings; background for the upper half is light blue with white rays outlined in black; the sun is orange with a yellow background; the lizard is green with black and yellow markings, the eye and teeth are white; and the trident is black.



The squadron's "Green Lizard" insignia.

Nickname: Green Lizards, 1972-present.

### Chronology of Significant Events

**Apr 1973:** The squadron provided support for Operation End Sweep, the clearing of mine fields along the coast of North Vietnam.

**Apr 1975:** Squadron aircraft participated in Operation Frequent Wind, the evacuation of American personnel from Saigon. The squadron provided armed escort flights over the Saigon area for protection of the helos conducting the evacuation.

**15 May 1975:** The squadron participated in the recovery of the American merchant ship SS *Mayaguez* following its capture by Cambodian gunboats. The squadron flew sorties in support of the Marine landings on Koh Tang Island and retaliatory strikes against Cambodian targets. Squadron aircraft struck the airfield and naval facility at Ream, Cambodia. The squadron's KA-6D aircraft were used to provide tanker support for the combat sorties.

**18-19 Apr 1988:** The squadron participated in Operation Praying Mantis, retaliatory strikes against Iran after *Samuel B. Roberts* (FFG 58) struck an Iranian mine in international waters. Squadron aircraft attacked Iranian Boghammar speedboats, using Rockeye cluster bombs. They sunk one and damaged another. Later in the day, the Iranian frigate *Saband* fired missiles at two

of the squadron's aircraft while they were flying a surface combat air patrol for *Joseph Strauss* (DDG 16). The aircraft evaded the missiles and returned fire with two Harpoons and four laser-guided Skipper bombs. This attack was followed by a Harpoon firing from *Joseph Strauss*. The attack against the *Saband* left her blazing. Eventually the fires reached her magazines, and the final explosions lead to her sinking. Following this action the sister ship of the *Saband*, the *Sabalan*, left port and engaged several of the squadron's aircraft, firing a missile at them. One of the squadron's Intruders responded with a laser-guided bomb that hit *Sabalan*, and she went dead in the water. The *Sabalan* was taken in tow by an Iranian tug, her fantail partially submerged. VA-95's aircraft were ordered not to continue the attack. The squadron continued to fly combat sorties during 19 April but no other action resulted.

**Oct-Nov 1990:** During the *Abraham Lincoln's* (CVN 72) cruise from the East to West Coast via Cape Horn, the squadron participated in joint exercises with the Argentinean, Chilean, and Ecuadorian Armed Forces.

### Home Port Assignments

Location	Assignment Date
NAS Whidbey Island	01 Apr 1972

### Commanding Officers

	Date Assumed Command
CDR G. E. Wales	01 Apr 1972
CDR W. D. Zirbel	1973
CDR Van F. Westfall	05 Apr 1974
CDR Jerry W. Rogers	1974
CDR Robert M. McEwen	29 Oct 1976
CDR Ken G. Craig	27 Jan 1978
CDR Richard J. Toft	1979
CDR Patrick C. Hauert	21 Aug 1980
CDR Richard C. Wolter	10 Dec 1981
CDR Raymond T. Wojcik	02 Feb 1983
CDR John S. McMahan, Jr.	01 Aug 1984
CDR Jeremy C. Rosenberg	01 Feb 1986
CDR William H. Miller	19 Jun 1987
CDR John F. Schork	01 Dec 1988
CDR John R. Worthington	25 May 1990

### Aircraft Assignment

Type of Aircraft	Date Type First Received
A-6A	1972*
A-6B	1972†
KA-6D	1972†
A-6E	04 Feb 1976

\* The squadron received their first A-6A Intruders sometime between April and June 1972.

† The squadron received their first A-6B and KA-6Ds sometime between October and December 1972.

**Major Overseas Deployments**

<i>Date of Departure</i>	<i>Date of Return</i>	<i>Air Wing</i>	<i>Carrier</i>	<i>Type of Aircraft</i>	<i>Area of Operation</i>
09 Mar 1973	08 Nov 1973	CVW-15	CVA 43	A-6A/B & KA-6D	WestPac
05 Dec 1974	02 Jul 1975	CVW-15	CVA 43	A-6A & KA-6D	WestPac
15 Feb 1977	05 Oct 1977	CVW-15	CV 43	A-6E & KA-6D	WestPac
13 Mar 1979	22 Sep 1979	CVW-11	CV 66	A-6E & KA-6D	Med
14 Apr 1981	12 Nov 1981	CVW-11	CV 66	A-6E & KA-6D	Med/IO
01 Sep 1982	28 Apr 1983	CVW-11	CVN 65	A-6E & KA-6D	NorPac/WestPac/IO
30 May 1984	20 Dec 1984	CVW-11	CVN 65	A-6E & KA-6D	WestPac/IO
15 Jan 1986	12 Aug 1986	CVW-11	CVN 65	A-6E & KA-6D	World Cruise
25 Oct 1987	24 Nov 1987	CVW-11	CVN 65	A-6E & KA-6D	NorPac
05 Jan 1988	03 Jul 1988	CVW-11	CVN 65	A-6E & KA-6D	WestPac/IO
17 Sep 1989	16 Mar 1990	CVW-11	CVN 65	A-6E & KA-6D	World Cruise
25 Sep 1990	20 Nov 1990	CVW-11	CVN 72	A-6E & KA-6D	East Coast to West Coast cruise via Cape Horn

**Air Wing Assignments**

<i>Air Wing</i>	<i>Tail Code</i>	<i>Assignment Date</i>
CVW-15	NL	1972
CVW-11	NH	01 Jul 1978

**Unit Awards Received**

<i>Unit Award</i>	<i>Inclusive Dates Covering Unit Award</i>	
AFEM	29 Apr 1975 15 May 1975	30 Apr 1975
	15 Feb 1988 25 Mar 1988	09 Mar 1988 19 Apr 1988

**Unit Awards Received—Continued**

<i>Unit Award</i>	<i>Inclusive Dates Covering Unit Award</i>	
HSM	29 Apr 1975	30 Apr 1975
	23 Oct 1982	
JMUA	18 Apr 1988	19 Apr 1988
NAVE	01 Jul 1980	31 Dec 1981
	01 Jan 1988	31 Dec 1988
	01 Jan 1990	31 Dec 1990
MUC	22 Apr 1975 15 May 1975	30 Apr 1975
	15 Feb 1988	21 May 1988
NEM	09 May 1981	18 Oct 1981
	30 Apr 1986	27 Jun 1986



*A squadron A-6E Intruder in flight, 1987.*

## VA-96

### Lineage

Established as Attack Squadron NINETY SIX (VA-96) on 30 June 1956.

Disestablished on 10 April 1958. The first squadron to be assigned the VA-96 designation.



VA-96's approved insignia.

### Squadron Insignia and Nickname

The squadron's insignia was approved by CNO on 20 February 1957. Colors for the eagle crest and sword insignia were: light blue background outlined in orange, with an orange scroll and black lettering; the shield was orange with a black stylized eagle; the eagle's wing feathers, tongue and feet were white; the sword and maces were yellow.

Nickname: unknown.

### Chronology of Significant Events

**4 Jun 1957:** The squadron's commanding officer, Commander M. K. Dennis, was lost in a night midair collision while operating from *Kearsarge* (CVA 33) off the coast of California.

**Sep 1957:** *Kearsarge* operated in the vicinity of Taiwan following the build up of Chinese communist forces opposite the offshore islands belonging to Taiwan.



A squadron AD Skyraider launches from *Kearsarge* (CVA 33) during its 1957–1958 western Pacific cruise.

### Home Port Assignments

Location	Assignment Date
NAS Miramar	30 Jun 1956
NAS Moffett Field	Aug 1956

### Commanding Officers

	Date Assumed Command
CDR Milton K. Dennis	30 Jun 1956
CDR Stanley E. Sloan	04 Jun 1957

### Aircraft Assignment

Type of Aircraft	Date Type First Received
AD-6	Jul 1956
AD-7	Mar 1957

### Major Overseas Deployments

Date of Departure	Date of Return	Air Wing	Carrier	Type of Aircraft	Area of Operation
09 Aug 1957	02 Apr 1958	ATG-3	CVA 33	AD-6/7	WestPac

### Air Wing Assignments

Air Wing	Tail Code	Assignment Date
ATG-3	Y/NC*	30 Jun 1956

\* The tail code was changed from Y to NC in 1957. The effective date for this change was most likely the beginning of FY 58 (1 July 1957).

## VA-104

### Lineage

Established as Fighter Squadron ONE HUNDRED FOUR (VF-104) on 1 May 1952.

Redesignated Attack Squadron ONE HUNDRED FOUR (VA-104) in December 1953.

Disestablished on 31 March 1959. The first squadron to be assigned the designation VA-104.

### Squadron Insignia and Nickname

There is no record of official approval for the squadron insignia. The insignia on file for the squadron was a missile being shot by a long bow with an atomic explosion in the background. Colors for this insignia were: a light blue background outlined in yellow; the water was medium blue and the atomic explosion was white with shades of light and medium blue; the long bow was red with a black bow string; the missile had a black body, yellow fins outlined in black, and a red tipped nose.



*There is no record of an official approval for this insignia.*

Nickname: Hell's Archers.

### Chronology of Significant Events

**Nov 1956:** During the Suez War the squadron operated from *Coral Sea* (CVA 43) off the coast of Egypt. It provided air support for the evacuation of Americans and foreign nationals from that country.

**Jul 1958:** The squadron operated from *Forrestal* (CVA 59) in the eastern Atlantic, ready to enter the Mediterranean if needed for the U.S. Marines' landing in Beirut, Lebanon.

### Home Port Assignments

Location	Assignment Date
NAAS Cecil Field*	01 May 1952
NAS Jacksonville	Apr 1953
NAS Cecil Field	Dec 1953
NAS Jacksonville	Feb 1957

\* NAAS Cecil Field was redesignated NAS Cecil Field on 30 June 1952.

### Commanding Officers

	Date Assumed Command
LT J. R. Mills (acting)	01 May 1952
LCDR R. E. Sequin	13 May 1952
LCDR Harold H. Brock	Nov 1952
CDR D. H. Johnson	Feb 1954
CDR George E. Ford	10 Mar 1955
CDR Jack N. Durio	Apr 1957

### Aircraft Assignment

Type of Aircraft	Date Type First Received
FG-1D	May 1952
F4U-5	Dec 1952
AD-6	Jan 1954



*A squadron F4U-5 aboard Randolph (CVA 15), circa 1953 (Courtesy Robert Lawson Collection).*

**Major Overseas Deployments**

<i>Date of Departure</i>	<i>Date of Return</i>	<i>Air Wing</i>	<i>Carrier</i>	<i>Type of Aircraft</i>	<i>Area of Operation</i>
07 Jul 1954	20 Dec 1954	CVG-10	CVA 43	AD-6	Med
13 Aug 1956	11 Feb 1957	CVG-10	CVA 43	AD-6	Med
02 Sep 1958	12 Mar 1959	CVG-10	CVA 59	AD-6	Med

**Air Wing Assignments**

<i>Air Wing</i>	<i>Tail Code</i>	<i>Assignment Date</i>
CVG-10	P/AK*	01 May 1952

\* The tail code was changed from P to AK in 1957. The effective date for this change was most likely the beginning of FY 58 (1 July 1957).



*A squadron AD Skyraider, piloted by Commander G. E. Ford, prepares to launch from Leyte (CVA 33) during carrier qualifications in 1955.*



## VA-105

### Lineage

Established as Attack Squadron ONE HUNDRED FIVE (VA-105) on 1 May 1952.

Disestablished on 1 February 1959. The first squadron to be assigned the designation VA-105.

### Squadron Insignia and Nickname



The squadron's only insignia, approved March 1953.

The squadron's insignia was approved by CNO on 2 March 1953. Colors for the winged canon and bomb insignia were: a black bomb superimposed on a yellow background with a red fuse on the bomb; the canon was red with black markings; and the wings were yellow with black markings.

Nickname: unknown.

### Chronology of Significant Events

**4 Mar 1958:** The squadron's commanding officer, Commander E. F. Ternasky, was killed during a night ditching astern of *Essex* (CVA 9).

**Jul–Aug 1958:** The squadron flew close air support missions during the landing of U.S. Marines in Beirut, Lebanon. Aircraft from VA-105 were the first to be on station during the landings. Squadron aircraft flew road and border reconnaissance sorties. Several aircraft were damaged by ground fire on their reconnaissance missions. However, all aircraft returned to the *Essex* safely.

**Sep 1958:** When the Chinese communists began shelling the Quemoy Island group in August, *Essex* was ordered to transit the Suez Canal and report to the Seventh Fleet for duty in the Taiwan Straits. The squadron flew numerous sorties in the Taiwan Straits until relieved on 26 September.

**Nov 1958:** When the squadron was assigned to Replacement Air Group 4, its mission was changed to training personnel in the AD-6 Skyraider for assignment to fleet operating squadrons.

### Home Port Assignments

Location	Assignment Date
NAAS Cecil Field*	01 May 1952
NAS Jacksonville	Jul 1955
NAS Cecil Field	Apr 1956
NAS Jacksonville	Nov 1958

\* NAAS Cecil Field was redesignated NAS Cecil Field on 30 June 1952.

### Commanding Officers

	Date Assumed Command
CDR F. C. Auman	01 May 1952
LCDR R. S. Reeves	Aug 1953
CDR Samuel W. Forrer	Oct 1954
CDR Eugene F. Ternasky	Jun 1956
CDR L. W. S. Cummins	16 Mar 1958
LCDR U. W. Patrick, Jr.	08 Dec 1958

### Aircraft Assignment

Type of Aircraft	Date Type First Received
AD-1	09 May 1952
AD-4	22 Sep 1952
AD-4NA	Sep 1952
AD-6	Nov 1954



A squadron AD-4 Skyraider coming in for a landing during deployment aboard *Tarawa* (CVA 40) in 1953.

**Major Overseas Deployments**

<i>Date of Departure</i>	<i>Date of Return</i>	<i>Air Wing</i>	<i>Carrier</i>	<i>Type of Aircraft</i>	<i>Area of Operation</i>
07 Jan 1953	03 Jul 1953	CVG-10	CVA 40	AD-4/4NA	Med
31 Oct 1955	16 Apr 1956	ATG-201	CVA 20	AD-6	WestPac
02 Feb 1958	17 Nov 1958	ATG-201	CVA 9	AD-6	Med/WestPac

**Air Wing Assignments**

<i>Air Wing</i>	<i>Tail Code</i>	<i>Assignment Date</i>
CVG-10	P	01 May 1952
ATG-201	J/AP*	1954
RCVG-4	AD	16 Nov 1958

\* The tail code was changed from J to AP in 1957. The effective date for this change was most likely the beginning of FY 58 (1 July 1957).

**Unit Awards Received**

<i>Inclusive Dates Covering Unit Award</i>	
01 Jul 1953	30 Jun 1954
01 Jul 1954	30 Jun 1955
16 Jul 1958	01 Aug 1958
11 Aug 1958	20 Aug 1958

## SECOND VA-106

### Lineage

Established as Bomber-Fighter Squadron SEVENTEEN (VBF-17) on 2 January 1945.

Redesignated Fighter Squadron SIX B (VF-6B) on 15 November 1946.

Redesignated Fighter Squadron SIXTY TWO (VF-62) on 28 July 1948.

Redesignated Attack Squadron ONE HUNDRED SIX (VA-106) on 1 July 1955.

Disestablished on 7 November 1969. The second squadron to be assigned the VA-106 designation.

### Squadron Insignia and Nickname

The squadron's first insignia was approved by CNO on 23 November 1945. Colors for the skeleton riding a rocket were:



*The squadron's first insignia.*

a background with a deep purple sky, aquamarine water and white clouds outlined in pale blue; the skeleton had a deep purple sombrero, a white face with light green shading and deep purple sockets, magenta shirt with an orange neckerchief, the hands were white with light green markings, teal trousers with a light blue cuff, tan boots with a brown sole, dark purple stirrups, tan saddle with pommel and under-portions brown; light gray rocket outlined in purple with yellow and orange lines emanating from the tail, light gray pistol outlined in purple with yellow smoke, magenta bomb, and a brown belt and holster.

Colors for the skeleton riding a rocket were: a background with a deep purple sky, aquamarine water and white clouds outlined in pale blue; the skeleton had a deep purple sombrero, a white face with light green shading and deep purple sockets, magenta shirt with an orange neckerchief, the hands were white with light green markings, teal trousers with a light blue cuff, tan boots with a brown sole, dark purple stirrups, tan saddle with pommel and under-portions brown; light gray rocket outlined in purple with yellow and orange lines emanating from the tail, light gray pistol outlined in purple with yellow smoke, magenta bomb, and a brown belt and holster.

A new insignia was approved by CNO on 16 April 1952. Colors for the helmet and shield insignia were: a gold background outlined in dark blue; dark blue shield; the Roman helmet was gold with black markings; white arrow and stylized wing; and the scroll was gold with black lettering.

A new insignia was approved by CNO on 16 April 1952. Colors for the helmet and shield insignia were: a gold background outlined in dark blue; dark blue shield; the Roman helmet was gold with black markings; white arrow and stylized wing; and the scroll was gold with black lettering.



*This insignia was adopted by the squadron in the early 1950s. Following the squadron's disestablishment a new strike fighter squadron adopted this insignia in the 1980s.*

Nickname: unknown, 1945–1952.

Gladiators, 1952–1969.

### Chronology of Significant Events

**Jan 1945:** The squadron was established only a month before it entered combat. Personnel from VF-17 were the core of the newly established Bomber Fighter Squadron 17.

**16–17 Feb 1945:** The squadron participated in strikes against targets in and around the Tokyo area.

**20–22 Feb 1945:** Squadron aircraft participated in strikes against Iwo Jima and provided air support for the landings on the island.

**25 Feb 1945:** Conducted strikes in the Tokyo area.

**18–19 Mar 1945:** Major strikes were conducted by squadron aircraft against Kanoya, the largest airfield on Kyushu and against the Japanese Fleet anchored at Kure Naval Base. On 19 March Lieutenant Edwin S. Conant was awarded the Silver Star for his action as flight leader on a fighter sweep over the Kure Bay. He shot down three planes during an engagement with the enemy and his flight group accounted for a total of 24 enemy planes downed and probably eight or more damaged.

**21 Mar 1945:** Lieutenant (jg) Henry E. Mitchell became an Ace when he shot down five Bettys (Japanese Navy Mitsubishi Attack Bombers) that were part of a sortie attacking the squadron's task force. He was later killed in action on 3 April 1945. For his action on 21 March he was awarded the Navy Cross posthumously.

**Mar–May 1945:** The squadron conducted strikes in support of the Okinawa campaign.

**6 Apr 1945:** Ensign Harold Yeremain became an Ace when he added three more aircraft to his total by downing two Zekes (Mitsubishi A6M Fighters, commonly known as Zeros) and one Val (an Aichi Navy Carrier Bomber) during an engagement near Okinawa. Ensigns John J. Gafeney and William J. Kostik were awarded Silver Stars for their actions in shooting down three Japanese aircraft each during this engagement.

**7 Apr 1945:** The unit participated in the combined task force strikes against the super battleship *Yamato* and its accompanying escorts, resulting in the sinking of *Yamato*, two cruisers and three destroyers.

**7 Apr 1945:** Lieutenant Byron A. Eberts became an Ace when he brought his total to five by shooting down a Francis (a Yokosuka Japanese Navy Night Fighter).

**12 Apr 1945:** Lieutenant Edwin S. Conant became an Ace when he shot down a Zeke (Zero) and a Tojo (a Japanese Army Nakajima Fighter) and brought his tally to six aircraft downed.

**14 Apr 1945:** Ensigns Robert A. Clarke and William

J. Kostik became Aces when they each shot down a Zeke (Zero).

**16 Apr 1945:** Lieutenant John M. Johnston became an Ace when he shot down four Zekes (Zeros), bringing his total to eight aircraft. For his action during this engagement he was awarded the Silver Star.

**May 1945:** The squadron participated in strikes against Kyushu and Shikoku, hitting aircraft plants and airfields.

**14 May 1945:** The squadron's commanding officer, Lieutenant Commander H. W. Nicholson, was killed in action during a strike against Kyushu.

**14 May 1945:** Lieutenant (jg) Carl V. Stone became an Ace when he added two Franks (a Japanese Army Fighter) to his total of downed aircraft.

**Aug 1956:** Following the nationalization of the Suez Canal by Egypt on 26 July, *Coral Sea* (CVA 43) was ordered to the eastern Mediterranean as tensions increased and France and the United Kingdom began preparations for military action against Egypt.

**Oct–Nov 1956:** On 29 October Israel invaded Egypt and a day later France and the United Kingdom joined in the invasion, with the intent of reoccupying the Suez Canal. *Coral Sea* was on station in the eastern Mediterranean during the American evacuation of Western nationals from Egypt and Israel.

**Jul 1959:** During the NATO exercise Riptide, held off the east coast of the United States, the squadron conducted cross deck operations with the British carrier HMS *Victorious*.

**15–28 Nov 1960:** Following a request from Guatemala and Nicaragua, a Navy patrol was established off the coast of these Central American countries to prevent infiltration by communists from Cuba. The squadron operated from *Shangri-La* (CVA 38) as part of the patrol force.

**2–19 Jun 1961:** Following the assassination of the Dominican Republic's dictator, General Rafael Trujillo, the squadron operated from *Shangri-La* off the coast of that country until the domestic situation began to stabilize.

**22 Oct–28 Nov 1962:** During the Cuban Missile Crisis the squadron was assigned to the U.S. Air Force's 19th Tactical Air Force, in an alert status.

**May 1963:** The squadron operated from *Shangri-La* in the Caribbean during the period of unrest in Haiti and the civil strife with the Dominican Republic.

**29 Jul 1967:** After four days on the line at Yankee Station tragedy struck *Forrestal* (CVA 59). A Zuni rocket was accidentally ignited on the flight deck causing a chain reaction of explosions among the aircraft loaded with bombs and fuel. The squadron lost eight people out of the 132 killed, two missing and presumed dead and 62 injured. Those killed were Petty Officers H. Fontenot, W. W. Stewart, R. N. Plesh, J. A. Earick and Airman C. R. Rich, J. A. Velez, A. R. Metz and G. E. Wall. Numerous squadron personnel were cited for their acts of heroism during the tragedy.



A squadron F8F-2 Bearcat prepares for launch from *Coral Sea* (CVB 43) in September 1948 (Courtesy David Lucabaugh Collection).

### Home Port Assignments

Location	Assignment Date
NAS Agana	02 Jan 1945*
NAS Alameda	08 Jul 1945
NAAS Fallon	Sep 1945
NAS Brunswick	Feb 1946
NAS Norfolk	1946†
NAAS Oceana	25 Sep 1948
NAS Norfolk	22 Nov 1948
NAAS Oceana	20 Jan 1949
NAAS Cecil Field	18 Sep 1950‡
NAS Jacksonville	13 Oct 1952
NAS Cecil Field	Dec 1954

\* Temporary shore assignment while the squadron conducted training in preparation for combat deployment.

† The squadron was transferred from NAS Brunswick to NAS Norfolk sometime in July or August 1946.

‡ The squadron's home port was changed to NAS Jacksonville on 5 September 1950 and the move from NAAS Oceana was conducted between 6 and 7 September. On 18 September, Commander Fleet Air Jacksonville changed the squadron's home port to NAAS Cecil Field.



Two squadron F2H-2 Banshees fly over Lake Champlain (CVA 39) during their 1953 deployment to Korea.

**Commanding Officers**

	<i>Date Assumed Command</i>
LCDR Hugh W. Nicholson	11 Jan 1945
LT Edwin S. Connant (acting)	14 May 1945
LCDR Edwin S. Connant	20 Aug 1945
CDR C. E. Houston	01 Jul 1947
LCDR Walter O. Zoecklein (acting)	1948
LCDR James E. Shew	02 Jul 1948
LCDR Hugh A. Kelly	03 Jan 1950
CDR Douglas A. Clark	19 Oct 1951
LCDR William W. Kelly	25 Nov 1952
CDR Lewis W. Jenkins	27 Feb 1954
CDR Hollis H. Hills	Jul 1955
CDR O. L. Dauphin	Feb 1957
CDR Newton P. Foss	25 Apr 1958
CDR S. O. Bach	05 Dec 1959
CDR L. W. Baldwin, Jr.	22 Jul 1960
CDR L. E. Irvin	31 Jul 1961
CDR W. S. Nelson	25 Jul 1962
CDR G. E. R. Kinnear II	Jul 1963
CDR C. B. Crockett	1 Aug 1964
CDR James H. Scott	Jun 1965
CDR S. R. Foley, Jr.	24 Jun 1966
CDR S. E. Latimer, Jr.	07 Aug 1967
CDR Walter L. Clarke, Jr.	17 Nov 1967
CDR J. H. Harns	03 Mar 1969



*Squadron CO, Commander H. H. Hills, inspecting an F2H-2, 1955.*

**Aircraft Assignment**

<i>Type of Aircraft</i>	<i>Date Type First Received</i>
F6F-5	Jan 1945
F4U	Sep 1945
F4U-4	Feb 1946
F8F-2	30 Jun 1948
F8F-1B	Feb 1950
F2H-2	03 Aug 1950
F9F-8B	Oct 1955
A4D-2	04 Jun 1958
A-4C	18 Dec 1962
A-4E	Nov 1966
A-4B	Feb 1969
A-4C	Mar 1969



*Personnel discuss the refueling probe on a squadron F9F-8 Cougar, 1955.*

**Major Overseas Deployments**

<i>Date of Departure</i>	<i>Date of Return</i>	<i>Air Wing</i>	<i>Carrier</i>	<i>Type of Aircraft</i>	<i>Area of Operation</i>
10 Feb 1945	13 Jun 1945	CVG-17	CV 12	F6F-5	Pacific
27 Oct 1949	23 Nov 1949	CVG-6	CVB 42	F8F-2	NorLant
15 May 1951	04 Oct 1951	CVG-4	CV 34	F2H-2	Med
19 Apr 1952	12 Oct 1952	CVG-4	CVB 43	F2H-2	Med
26 Apr 1953	04 Dec 1953	CVG-4	CVA 39	F2H-2	Korea/West Pac/Med
07 Jul 1954	20 Dec 1954	CVG-10	CVA 43	F2H-2	Med
13 Aug 1956	11 Feb 1957	CVG-10	CVA 43	F9F-8B	Med
07 Aug 1959	26 Feb 1960	CVG-10	CVA 9	A4D-2	Med
06 Sep 1960	20 Oct 1960	CVG-10	CVA 38	A4D-2	NorLant
02 Feb 1961	15 May 1961	CVG-10	CVA 38	A4D-2	Med
07 Feb 1962	28 Aug 1962	CVG-10	CVA 38	A4D-2	Med
01 Oct 1963	23 May 1964	CVW-10	CVA 38	A-4C	Med
15 Feb 1965	20 Sep 1965	CVW-10	CVA 38	A-4C	Med
11 Mar 1966	26 Oct 1966	CVW-3	CVA 60	A-4C	Med
06 Jun 1967	15 Sep 1967	CVW-17	CVA 59	A-4E	WestPac/Vietnam
04 Jun 1968	08 Feb 1969	CVW-10	CVS 11	A-4E	WestPac/Vietnam
03 Sep 1969	09 Oct 1969	CVW-7	CVA 62	A-4C	NorLant



*Squadron A-4C Skyhawks fly over Saratoga (CVA 60), 1966.*

**Air Wing Assignments**

Air Wing	Tail Code	Assignment Date
CVG-17/CVBG-17/ CVBG-5/CVG-6*	C	02 Jan 1945
CVG-4	F	Sep 1950
CVG-10	P/AK†	1954
CVG-1‡		12 Oct 1961
CVG-10/CVW-10§	AK	12 Nov 1961
CVW-3	AC	01 Jan 1966
CVW-17	AA	01 Feb 1967
CVW-10	AK	10 Jan 1968
CVW-7	AG	03 Mar 1969

\* CVG-17 was established on 1 January 1943, redesignated CVBG-17 on 22 January 1946, then redesignated CVBG-5 on 15 November 1946. CVBG-5 was then redesignated CVG-6 on 27 July 1948.

† The tail code was changed from P to AK in 1957. The effective date for this change was most likely the beginning of FY 58 (1 July 1957).

‡ The squadron was temporarily assigned to Air Group 1 for operation Blow Torch, simulated nuclear strikes against North American targets, and for nuclear operational suitability tests aboard *Franklin D. Roosevelt* (CVA 42).

§ CVG-10 was redesignated CVW-10 when Carrier Air Group (CVG) designations were redesignated Carrier Air Wings (CVW) on 20 December 1963.

**Unit Awards Received**

Unit Award	Inclusive Dates Covering Unit Award	
PUC	16 Feb 1945	10 Jun 1945
Campaign Medal WW-II Asiatic- Pacific Area	Feb 1945	Jun 1945
NAVE	01 Jul 1949	30 Jun 1950
	01 Jul 1955	30 Jun 1956
	01 Jul 1959	30 Jun 1960
	01 Jul 1965	31 Dec 1966
KPUC	09 Jun 1953	27 Jul 1953
KSM	09 Jun 1953	27 Sep 1953
VNSM	15 Jul 1967	17 Jul 1967
	23 Jul 1967	31 Jul 1967
	12 Aug 1967	13 Aug 1967
	05 Sep 1968	27 Sep 1968
	14 Oct 1968	14 Nov 1968
	03 Dec 1968	27 Dec 1968
NEM	03 Jun 1961	11 Jun 1961
	14 Jun 1961	18 Jun 1961



Squadron officers and an A-4C on *Saratoga* (CVA 60) during its 1966 cruise to the Med. Standing left to right: Marine Capt. J. W. Orr, LCdr. C. C. Smith, LCdr. J. E. Potosnak, LCdr. P. E. Phillips, Lt. W. R. Needham, LCdr. J. L. Burton, Lt. (jg) J. B. Mattly, Lt. S. C. Cole, LCdr. K. A. McMillen and Lt. E. L. DeSha. Kneeling left to right: Lt. (MC) H. K. Leathers III, Lt. L. W. Scott, Ens. M. W. Davis, Cdr. J. H. Scott, Cdr. S. R. Foley, Jr., Lt. (jg) R. L. Mattingly, Lt. R. A. Pennington, Ens. J. E. Gause and WO1 G. E. Connolly.

## VA-112

### Lineage

Established as Bomber-Fighter Squadron ELEVEN (VBF-11) on 9 April 1945.

Redesignated Fighter Squadron TWELVE A (VF-12A) on 15 November 1946.

Redesignated Fighter Squadron ONE HUNDRED TWELVE (VF-112) on 15 July 1948.

Redesignated Attack Squadron ONE HUNDRED TWELVE (VA-112) on 15 February 1959.

Disestablished on 10 October 1969. The first squadron to be assigned the designation VA-112.

### Squadron Insignia and Nickname

The squadron's first insignia was approved by CNO on 28 August 1945. Colors for the dragon and two headed eagle were: a yellow background; black dragon; sky blue eagle with white heads and red tongues; other markings and outlines were black.



*The squadron's first insignia was the double-headed eagle and dragon.*

A new squadron insignia was approved by CNO on 9 November 1945. There is no color description of this insignia in the official files. This insignia continued to use the two-headed eagle. It replaced the dragon with a globe showing North and South America. Clouds surrounded the globe.

The CNO approved a new squadron insignia on 12 July 1948. Colors for the Custode Pacis Armis (Armed Keeper of the Peace) insignia were: a light blue background; the rocket and machine gun were black with white highlights; gold naval aviator wings outlined in black; upper half of the shield was purple and lower half was dark green; the motto on the shield had a white background with light blue lettering; the dove was white with a red eye and green wreath in its beak; gray helmet highlighted in black, with a red plum; black sword; the shield and items on the shield were outlined in black; and the banner below the shield was white.



*The squadron's second insignia replaced the dragon with a globe of the world surrounded by clouds.*



*The Custodes Pacis Armis insignia became the squadron's third design.*



*This was the squadron's last insignia, a modification of the Custodes Pacis Armis design.*

The squadron continued to use the Custode Paris Armis insignia following its redesignation to VA-112. However, the following color modifications were made: background was yellow outlined in black; upper half of shield was blue; lettering for the motto was red; the white banner was removed and a lower scroll was added with a yellow background and black lettering.

Nickname: Broncos, 1961–1969.

### Chronology of Significant Events

**25 Mar 1948:** *Valley Forge* (CV 45) operated in the Persian Gulf with Saudi Arabian Prince Ibn Saud embarked to view air operations. However, the air display was cancelled because of a sand storm and hazy conditions.

**29 Apr 1948:** *Valley Forge* (CV 45) moored port side to Dokkeskjaerkaien Dock, Bergen, Norway. The mooring was conducted without the aid of tugs, using the engine power of the squadron's eight F8Fs spotted on the forward deck and eight other aircraft on the aft deck. The mooring operation was called "Operation Pinwheel."

**5 Aug 1950:** The squadron participated in its first combat operations, flying sorties against targets in the Mokpo-Kwangju area of South Korea.

**12–19 Sep 1950:** The squadron participated in the pre-assault strikes against targets in and around Inchon, Korea, in preparation for the landings there on 15 September. These strikes included road, rail, and airfield sweeps and Combat Air Patrol. During and after the invasion the squadron continued to fly daily air sweeps, striking at targets of opportunity and the enemy's lines of communications.

**10 Nov 1950:** The squadron's first encounter with MiG-15s occurred during a sortie over Sinuiju, Korea. One MiG-15 was damaged during the engagement.

**23–24 June 1952:** The squadron participated in coordinated strikes against North Korean hydroelectric power plants, the first heavy attack conducted against these installations. Nine different hydroelectric power plants were struck by forces from Carrier Air Groups 2, 7, 11, 19, and the 5th Air Force.



**6–13 Feb 1955:** The squadron was on station and available for air support during the evacuation of over 26,000 personnel from the Tachen Islands which had come under bombardment by the People’s Republic of China in January 1955.

**24 Apr 1967:** Squadron aircraft participated in a multi-carrier coordinated strike against North Vietnam’s MiG base, Kep Airfield, northeast of Hanoi. This was the first time a strike had been conducted against a North Vietnam MiG airfield.

**10 May 1967:** Commander M. L. Minnis, Sr., was awarded the Silver Star for action during a strike into North Vietnam against the thermal power plant at Haiphong.

**Apr 1969:** Following the shoot down of a Navy EC-121 aircraft by the North Koreans, *Ticonderoga* (CVA 14), along with two other attack carriers, was ordered to the Sea of Japan.



The squadron’s snow-covered F8F-1 Bearcats, along with VF-11A’s F8Fs, on the forward flight deck of Valley Forge (CV 45) during her visit to Bergen, Norway, in 1948.

### Home Port Assignments

Location	Assignment Date
NAS Alameda	09 Apr 1945
NAAS Fallon	30 Apr 1945
NAAS Santa Rosa	31 Jul 1945
NAS Kahului, Hawaii	21 Feb 1946
NAS San Diego	25 Nov 1946
NAAS Miramar/NAS Miramar*	07 Apr 1951
NAS Lemoore	11 Sep 1961

\* NAAS Miramar was redesignated NAS Miramar on 1 March 1952.

### Commanding Officers

	Date Assumed Command
LT Richard E. James (acting)	09 Apr 1945
LCDR Ralph W. Cousins	17 Apr 1945
LCDR George E. Savage	09 Jun 1945
LCDR Norman W. Ackley	14 Oct 1945
LCDR Melvin C. Hoffman	31 Jan 1947
CDR Joseph T. Lawler	01 Jul 1948
CDR R. Weymouth	08 May 1950
LCDR J. L. Butts, Jr.	29 Aug 1950
LCDR J. V. Rowney	29 Jun 1951
LCDR James Ferris	11 Aug 1952
LCDR R. W. Jackson (acting)	01 Oct 1952
LCDR C. E. Lair	07 Oct 1952
CDR George S. Morrison	Mar 1954
CDR Marcel N. Piller	01 Oct 1955
LCDR M. M. Casey, Jr.	12 Apr 1957
LCDR J. J. Konzen (acting)	04 Mar 1959
CDR Clyde J. Lee	31 Mar 1959
CDR Hugh N. Batten	18 Feb 1960
CDR James T. Parady	30 Mar 1961
CDR J. F. Kirklighter	25 Apr 1962
CDR F. L. Leib	09 Apr 1963
CDR P. E. Russell	08 May 1964
CDR J. A. Chalbeck	08 Jun 1965
CDR J. H. Alvis	08 Jul 1966
CDR Marion L. Minnis	31 Dec 1966
CDR Charles H. Brown	10 Nov 1967
CDR Tommy L. Gatewood	13 Sep 1968



A squadron F9F-2B Panther launches from the deck of Philippine Sea (CV 47) during her combat cruise to Korea in 1951–1952.

### Aircraft Assignment

Type of Aircraft	Date	Type First Received
F6F-3/5		Apr 1945
F8F-1		11 Dec 1946
F8F-2		03 Jan 1949
F9F-2		11 Jan 1950
F9F-2B*		Jul 1950
F9F-3		31 May 1951
F9F-2B		12 Jul 1951
F9F-5		Oct 1952
F9F-6		Feb 1954

**Aircraft Assignment—Continued**

<i>Type of Aircraft</i>	<i>Date</i>	<i>Type First Received</i>
F9F-8		Jul 1955
F9F-8B		Apr 1956
F3H-2M		05 Apr 1957
A4D-1/2		Apr 1959
A4D-2N/A-4C†		26 Mar 1961

\* The squadron's F9F-2s were modified at NAS Barbers Point and equipped with rocket launchers and bomb racks and designated F9F-2Bs.

† The A4D-2N designation was changed to A-4C in 1962.



A squadron F9F-8B Cougar on the deck of Essex (CVA 9) following a successful landing during deployment to WestPac in 1956–1957.

**Major Overseas Deployments**

<i>Date of Departure</i>	<i>Date of Return</i>	<i>Air Wing</i>	<i>Carrier</i>	<i>Type of Aircraft</i>	<i>Area of Operation</i>
09 Oct 1947	11 Jun 1948	CVAG-11	CV 45*	F8F-1	World Cruise
05 Jul 1950	07 Apr 1951	CVG-11	CV 47†	F9F-2B	WestPac/Korea
31 Dec 1951	08 Aug 1952	CVG-11	CV 47	F9F-2B	WestPac/Korea
01 Jul 1953	18 Jan 1954	CVG-11	CVA 33	F9F-5	WestPac
07 Oct 1954	12 May 1955	CVG-11	CVA 33	F9F-6	WestPac
16 Jul 1956	26 Jan 1957	CVG-11	CVA 9	F9F-8B	WestPac
04 Oct 1958	16 Feb 1959	ATG-1	CVA 14	F3H-2M	WestPac
16 Jul 1960	18 Mar 1961	CVG-11	CVA 19	A4D-2	WestPac
13 Sep 1962	02 Apr 1963	CVG-11	CVA 63	A-4C	WestPac
17 Oct 1963	20 Jul 1964	CVW-11	CVA 63	A-4C	WestPac
24 Aug 1965	07 Apr 1966	CVW-8	CVA 59	A-4C	Med
05 Nov 1966	19 Jun 1967	CVW-11	CVA 63	A-4C	WestPac/Vietnam
18 Nov 1967	28 Jun 1968	CVW-11	CVA 63	A-4C	WestPac/Vietnam
01 Feb 1969	18 Sep 1969	CVW-16	CVA 14	A-4C	WestPac/Vietnam

\* During October through December the squadron operated primarily from NAS Barbers Point with occasional exercises aboard *Valley Forge* (CV 45).

† While docked at Yokosuka, Japan, the squadron transferred from *Philippine Sea* (CV 47) to *Valley Forge* (CV 45) on 30 March 1951 for its return trip to the U.S. *Philippine Sea* continued its tour of duty in Korea with another air group.

**Air Wing Assignments**

<i>Air Wing</i>	<i>Tail Code</i>	<i>Assignment Date</i>
CVG-11/CVAG-11/ CVG-11*	V†/NH‡	09 Apr 1945
COMFAIRSANDIEGO		03 Mar 1958
ATG-1	NA	28 Jun 1958
CVG-5	NF	13 Mar 1959
CVG-11/CVW-11§	NH	Nov 1959
CVW-8	AJ	08 Jul 1965
COMFAIRALAMEDA		08 Apr 1966
CVW-11	NH	1966**
CVW-16	AH	01 Oct 1968

\* CVG-11 was redesignated CVAG-11 on 15 November 1946. It was redesignated CVG-11 on 1 September 1948.

† The tail code V was assigned to CVG-11 on 12 December 1946.

‡ The tail code was changed from V to NH in 1957. The effective date for this change was most likely the beginning of FY 58 (1 July 1957).

§ CVG-11 was redesignated CVW-11 when Carrier Air Group (CVG) designations were redesignated Carrier Air Wings (CVW) on 20 December 1963.

\*\* VA-112 was reassigned to CVW-11 sometime between June and November 1966. There are no records available for VA-112 and CVW-11 for this period.



*A flight of squadron F3H-2M Demons, circa 1957–1958.*

**Unit Awards Received**

<i>Unit Award</i>	<i>Inclusive Dates Covering Unit Award</i>	
KPUC	01 Aug 1950	16 Mar 1951
	20 Jan 1952	12 Jul 1952
NUC	04 Aug 1950	16 Mar 1951
	20 Apr 1969	27 Apr 1969
AFEM	29 Jun 1969	
	07 Jul 1969	13 Jul 1969
	24 Jul 1969	
	04 Aug 1969	
	16 Aug 1969	24 Aug 1969
	30 Aug 1969	
	03 Sep 1969	
	13 Sep 1969	14 Sep 1969

**Unit Awards Received—Continued**

<i>Unit Award</i>	<i>Inclusive Dates Covering Unit Award</i>	
MUC	18 Feb 1969	07 Sep 1969
PUC	23 Dec 1967	01 Jun 1968
VNSM	03 Dec 1966	03 Jan 1967
	02 Mar 1967	28 Mar 1967
	12 Apr 1967	28 Apr 1967
	08 May 1967	23 May 1967
	04 Mar 1968	27 Mar 1968
	12 Apr 1968	01 May 1968
	13 May 1968	01 Jun 1968
	03 Mar 1969	20 Mar 1969
	29 Mar 1969	16 Apr 1969
	09 May 1969	04 Jun 1969
	25 Jun 1969	01 Aug 1969



*A squadron A-4C Skyhawk lands aboard Kitty Hawk (CVA 63), circa 1967–1968.*

## VA-114

### Lineage

Established as Bombing Squadron ELEVEN (VB-11) on 10 October 1942.

Redesignated Attack Squadron ELEVEN A (VA-11A) on 15 November 1946.

Redesignated Attack Squadron ONE HUNDRED FOURTEEN (VA-114) on 15 July 1948.

Disestablished on 1 December 1949. The first squadron to be assigned the VA-114 designation.

### Squadron Insignia and Nickname



*This was the only insignia approved and used by the squadron.*

The squadron's insignia was approved by the Bureau of Aeronautics on 17 September 1942. Colors for the Bellerophon-Pegasus insignia were: a black winged horse, rider, and bomb with white highlights; and a red shield and helmet plume. The Greek motto translated as First to Attack.

Nickname: unknown.

### Chronology of Significant Events

**Apr–Jul 1943:** The squadron was landbased at Guadalcanal and participated in the Solomons Campaign. Flying patrol, search and strike missions against targets primarily in and around New Georgia.

**10 Oct 1944:** Squadron aircraft participated in the first strikes against Okinawa, opening the Leyte campaign.

**12 Oct 1944:** The squadron participated in the first strikes against Formosa.

**25 Oct 1944:** During the Battle for Leyte Gulf, the squadron participated in the engagement known as the Battle Off Samar. Launching from a range of 340 miles, which was beyond the normal combat radius for World War II carrier aircraft, 11 of the squadron's SB2Cs engaged the Japanese fleet after it broke off its engagement with the American escort carriers and destroyers guarding the landing force at Leyte. Hits were scored on a battleship and cruiser. A second strike by nine squadron aircraft later scored hits on two cruisers.

**Nov 1944:** Squadron aircraft struck targets on Luzon in continued support for the capture of Leyte.

**Dec 1944:** Targets were struck on Luzon in support of the landings on Mindoro.

**18 Dec 1944:** While operating east of the Philippines, the task force, of which the squadron was part, was overtaken by an unusually severe typhoon causing the loss of three destroyers and damage to several other ships, including four light carriers.

**Jan 1945:** In early January, the squadron struck ships and targets on Formosa in support of the landings in Lingayen Gulf, Luzon.

**9–20 Jan 1945:** The squadron participated in operations in the South China Sea, the first time an American Task Force had entered these waters since the beginning of the war. During these operations, squadron aircraft struck a large convoy of tankers; targets along the coast of Indochina reaching almost to Saigon; Formosa was hit again; and then strikes were flown against Hong Kong.

**25 Mar 1948:** *Valley Forge* (CV 45) operated in the Persian Gulf with Saudi Arabian Prince Ibn Saud embarked to view air operations. The air display was cancelled because of a sand storm and hazy air conditions.

**29 Apr 1948:** *Valley Forge* moored port side to Dokkeskjaerkaien Dock, Bergen, Norway. The mooring was conducted without the aid of tugs, using the engine power of the squadron's eight SB2C-5s spotted on the aft deck and eight other aircraft on the forward deck. The mooring operation was called "Operation Pinwheel."



*A squadron SBD-3 Dauntless on the flight deck, circa late 1942 (Courtesy Robert Lawson Collection).*

**Home Port Assignments**

<i>Location</i>	<i>Assignment Date</i>
NAS San Diego	10 Oct 1942
NAS Barbers Point	26 Nov 1942*
NAF Nandi (in the Fiji Islands)	Feb 1943*
NAF Guadalcanal	26 Apr 1943
NAS Alameda	Aug 1943
NAS Hilo	06 Apr 1944*
NAS Barbers Point	19 Jun 1944*
NAS Alameda	Feb 1945
NAAS Fallon	30 Apr 1945*
NAAS Santa Rosa	26 Jul 1945*
NAS Kahului, Hawaii	21 Feb 1946
NAS San Diego	25 Nov 1946

\* Temporary shore assignment while the squadron conducted training in preparation for combat deployment.

**Commanding Officers**

	<i>Date Assumed Command</i>
LCDR Weldon L. Hamilton	10 Oct 1942
LCDR Raymond B. Jacoby	30 Sep 1943
LT Charles A. Skinner (acting)	01 Nov 1943
LCDR Lloyd A. Smith	15 Nov 1943

**Commanding Officers—Continued**

	<i>Date Assumed Command</i>
LT Eugene M. Yoder (acting)	01 Nov 1944
LCDR Edwin John Kroeger	07 Nov 1944
LTJG George G. Beckham (acting)	09 Apr 1945
LT Eugene M. Yoder (acting)	10 Apr 1945
LCDR Ried W. Stone	05 May 1945
LCDR Raymond A. Boyd	05 Jun 1947
LCDR F. E. Miller (acting)	16 Jun 1948
CDR Adolf L. Siegener	28 Jun 1948
LCDR J. E. Savage	30 Jun 1949
LCDR E. T. Deacon	01 Aug 1949

**Aircraft Assignment**

<i>Type of Aircraft</i>	<i>Date Type First Received</i>
SBD-3	Oct 1942
SBD-4	Feb 1943
SBD-5	Oct 1943
SB2C-1C	25 Nov 1943
SB2C-4/4E	Apr 1945
SB2C-5	Jan 1946
AD-1	31 Aug 1948
AD-2	20 Dec 1948
F8F-2	Nov 1949



*A squadron SB2C-5 flies over Gibraltar during its world cruise aboard Valley Forge (CV 45), 1948.*

**Major Overseas Deployments**

<i>Date of Departure</i>	<i>Date of Return</i>	<i>Air Wing</i>	<i>Carrier</i>	<i>Type of Aircraft</i>	<i>Area of Operation</i>
Feb 1943	Aug 1943	CVG-11	*	SBD-3/4	SoPac
29 Sep 1944	01 Feb 1945	CVG-11	CV 12†	SB2C-1C	Pacific
09 Oct 1947	11 Jun 1948	CVAG-11	CV 45‡	SB2C-5	World Cruise

\* The squadron was landbased during operations in the South Pacific.

† The squadron transferred to *Kasaan Bay* (CVE 69) on 1 February 1945 at Ulithi for its return trip back to the States.

‡ During October through December 1947 the squadron operated from NAS Barbers Point with occasional exercises aboard *Valley Forge* (CV 45). The squadron departed NAS Barbers Point, embarked on *Valley Forge*, and continued on its world cruise, stopping at Australia, China, Singapore, Ceylon, Saudi Arabia, Gibraltar, Norway, England, New York, and Panama Canal Zone.

**Air Wing Assignments**

<i>Air Wing</i>	<i>Tail Code</i>	<i>Assignment Date</i>
CVG-11/CVAG-11/CVG-11†	V*	10 Oct 1942

\* The tail code V was assigned on 7 November 1946.

† CVG-11 was redesignated CVAG-11 on 15 November 1946. CVAG-11 was changed back to CVG-11 on 1 September 1948.

**Unit Awards Received**

<i>Unit Award</i>	<i>Inclusive Dates Covering Unit Award</i>	
PUC	10 Oct 1944	22 Nov 1944
	14 Dec 1944	16 Dec 1944
	03 Jan 1945	22 Jan 1945
Campaign Medal (Asiatic-Pacific)	08 Feb 1943	20 Jun 1943

**Unit Awards Received—Continued**

<i>Unit Award</i>	<i>Inclusive Dates Covering Unit Award</i>	
PUC	10 Oct 1944	29 Nov 1944
	14 Dec 1944	16 Dec 1944
	09 Jan 1945	12 Jan 1945
Campaign Medal (Asiatic-Pacific)	12 Jan 1945	16 Jan 1945



*A squadron AD-2 Skyraider loaded with weapons on the deck of Valley Forge (CV 45), circa 1949 (Courtesy Robert Lawson Collection).*

## VA-115

### Lineage

Established as Torpedo Squadron ELEVEN (VT-11) on 10 October 1942.

Redesignated Attack Squadron TWELVE A (VA-12A) on 15 November 1946.

Redesignated Attack Squadron ONE HUNDRED FIFTEEN (VA-115) on 15 July 1948. The first squadron to be assigned the VA-115 designation.

### Squadron Insignia and Nickname

The squadron's first insignia was approved by CNO on 25 June 1945. Colors for this Walt Disney designed



*The squadron's first insignia was designed by Walt Disney Studio.*

insignia were: a grayish blue background outlined in black with a wide outer red ring; deep green ocean; black torpedo with a white skull face and white markings and white streaks with black outlines and markings; the winged cherub was flesh color with white wings and eyes, black pupils and mouth, and a deep pink tongue; the cherub was wearing a deep green helmet and cream colored goggles with a black strap and black outlines.



*A new stylized globe and wing insignia was approved for use by the squadron in 1956 and has become a well-known design.*

A new squadron insignia was approved by CNO on 17 September 1956. Colors for the globe and abstract wing design are: a black background; white globe with black lines; white stylized clock hands; gold stars and abstract wing design; gold scroll outlined in black with black lettering.

Nickname: Arabs, 1950s–1979.  
Eagles, 1979-present.\*

### Chronology of Significant Events

**1 Jan–1 Feb 1943:** A detachment of 6 aircraft from the squadron were sent to Kanton Island, in the Phoenix Islands, for antisubmarine defense and search missions.

\* During the squadron's deployment to the Indian Ocean in 1989, they temporarily changed their nickname back to Arabs to enhance the esprit de corps while operating in the Arabian Sea.



*The squadron's C.O., LCdr. F. L. Ashworth, in his TBF-1 Avenger on Guadalcanal in May 1943.*

**Apr–Jul 1943:** The squadron was landbased at Guadalcanal and participated in the Solomons (New Georgia) Campaign. They flew patrol, search, spotting, strike, and night minelaying missions against targets in the Solomon Islands.

**5 May 1944:** Squadron aircraft were involved in an antisubmarine attack off the coast of Hilo, Hawaii. The attack against the enemy submarine was assessed as probable by the squadron commander.

**10 Oct 1944:** The squadron participated in the first strikes against Okinawa, part of the opening of the Leyte Campaign.

**25 Oct 1944:** The Japanese Fleet, in three elements, converged on Leyte to oppose the landings. While 340 miles from Leyte, which was beyond the normal combat radius for World War II carrier aircraft, squadron aircraft were launched for a strike on the central element of the Japanese Fleet. Its TBMs arrived over the enemy fleet after it had broken off its engagement, the Battle Off Samar, with the American escort carriers and destroyers guarding the landing and supply ships. The TBMs struck the retiring Japanese Central Fleet, scoring hits on a battleship and two cruisers. All the squadron's aircraft returned, completing a 600 mile round trip combat flight. For their actions during this engagement, the following squadron personnel were awarded the Navy Cross: Lieutenants Wilbur J. Engman, Melvin L. Tegge, and Thomas B. Adams and Lieutenant (jg)s Richard W. Russell, Lawrence E. Helmuth, John M. Davis and William Maier.

**26 Oct 1944:** Strikes continued against the Japanese Fleet and Lieutenant Leroy H. Grau was awarded the Navy Cross for a successful torpedo attack against a Japanese light cruiser.

**Nov 1944:** The squadron continued to provide support for the Occupation of Leyte, striking targets on Luzon.

**13 Nov 1944:** The squadron's commanding officer, Lieutenant Commander R. Denniston, Jr., was lost on a combat mission over Manila Harbor.

**Dec 1944:** Squadron aircraft struck targets on Luzon in support of the landings on Mindoro.

**18 Dec 1944:** While operating east of the Philippines the task force was overtaken by an unusually severe typhoon causing the loss of three destroyers and damage to several other ships, including four light carriers.

**Jan 1945:** In early January, the squadron struck ships and targets on Formosa and Luzon in support of the landings in Lingayen Gulf, Luzon.

**9–20 Jan 1945:** The squadron participated in operations in the South China Sea, the first time an American Task Force had entered these waters since the beginning of the war. The squadron struck targets at Cam Ranh Bay and a convoy off Qui Nhon, French Indo-China; shipping at the Pescadores Island; and Hong Kong.

**12–18 Sep 1950:** The squadron participated in the pre-assault strikes against targets in and around Inchon, Korea, in preparation for the landings there on 15 September. During and after the invasion, the squadron continued to fly deep support missions into the areas surrounding Inchon, striking at targets of opportunity.

**9 Nov 1950:** The squadron's first encounter with MiG-15s was during a mission against Sinuiju, Korea. All the aircraft returned safely to *Philippine Sea*.

**Dec 1950:** The squadron provided close air support for American troops in the Chosen Reservoir area.

**Feb–Jul 1952:** The squadron's combat missions in Korea during this time period centered on rail interdiction, with some strikes against North Korean transportation, communication, industrial and supply facilities.

**23–24 Jun 1952:** The squadron participated in coordinated strikes against North Korean hydroelectric power plants, these were the first heavy attacks conducted against these installations. Nine different hydroelectric power plants were struck by forces from Carrier Air Groups 2, 7, 11, 19, and the 5th Air Force.

**Feb 1955:** The squadron flew air cover missions during the evacuation of over 26,000 personnel from Tachen Islands which had come under bombardment by the People's Republic of China in January.

**Aug–Sep 1958:** The squadron was part of the task force that provided support to the Republic of China during the shelling of the Quemoy Island group by the Chinese Communists.

**May–Jun 1964:** During the Laotian crisis, the squadron flew Combat Air Patrol and Search and Rescue sorties over the country.

**Aug 1967–Jan 1970:** During this period the squadron was in an inactive stand-down status. There were no aircraft and only a few administrative personnel assigned. The inactive status was a transitional period, awaiting the time when the squadron would assume an active status and receive the A-6 Intruder. This is the only known instance in which a squadron was not disestablished but remained on the active squadron inventory in an inactive status. The squadron resumed an active status on 1 January 1970.

**May–Oct 1972:** The squadron participated in Linebacker I operations, heavy air strikes against targets in North Vietnam to interdict the flow of supplies.

**Apr–May 1975:** The squadron participated in Operation Frequent Wind, the evacuation of American personnel from Saigon, South Vietnam, as the country fell to the communists.

**Aug–Sep 1976:** The squadron operated near the Korean Peninsula following the murder of U.S. military personnel in the Korean DMZ by North Koreans.

**Apr–May 1979:** *Midway*, with VA-115 embarked, deployed to the Gulf of Aden to relieve *Constellation* (CV 64) and maintain a U.S. carrier presence following the outbreak of fighting between North and South Yemen and the fall of the Shah of Iran.

**Oct 1979:** As a response to anti-American demonstrations in Iran, *Midway* and its air wing, including VA-115, were ordered to deploy to the Indian Ocean for the second time in 1979.

**Nov–Dec 1979:** In response to the seizure of the American Embassy and its staff by an Iranian mob, *Midway* returned to the Arabian Sea.

**May–Jun 1980:** Following the massacre of several hundred people in the city of Kwangju, South Korea, the squadron operated from *Midway* off the coast of South Korea until the crisis subsided.

**Dec 1981:** Following unrest in South Korea the squadron operated from *Midway* off the coast of South Korea for several days.

**29 Feb 1988:** During an exercise in the Gulf of Siam, a squadron aircraft spotted a boatload of Vietnamese refugees, leading to their rescue by *Midway* (CV 41).

**Sep 1988:** During the Summer Olympics in Seoul, South Korea, the squadron was embarked on *Midway* and operating in the Sea of Japan to demonstrate U.S. support for a peaceful olympics.

**Nov 1990–Jan 1991:** The squadron flew missions in support of Operation Desert Shield, the build-up of American and Allied forces to counter a threatened invasion of Saudi Arabia by Iraq and were part of an economic blockade of Iraq to force its withdrawal from Kuwait.

**20 Jan–9 Mar 1991:** The squadron participated in Operation Desert Storm, striking Iraqi naval targets and bases, airfields and bridges, a communication center, and providing close air support for Allied ground forces.





*A squadron TBF-1 Avenger on Guadalcanal with Lt. (jg) George Gay, LCdr W. L. Hamilton and LCdr F. L. Ashworth, May 1943.*

### Home Port Assignments

<i>Location</i>	<i>Assignment Date</i>
NAS San Diego	10 Oct 1942
NAS Pearl Harbor	01 Nov 1942*
NAS Barbers Point	07 Nov 1942*
NAF Nandi (in the Fiji Islands)	28 Feb 1943*
NAF Guadalcanal (Henderson Field)	17 Apr 1943
NAS Alameda	19 Aug 1943
NAS Hilo	08 Apr 1944*
NAS Barbers Point	19 Jun 1944*
NAS Alameda	24 Feb 1945
NAAS Fallon	30 Apr 1945*
NAAS Santa Rosa	26 Jul 1945
NAS Kahalui	22 Feb 1946
NAS San Diego	26 Nov 1946
NAS Miramar	15 Sep 1952
NAS Moffett Field	08 Dec 1961†
NAS Lemoore	03 Apr 1963
NAS Whidbey Island	01 Jan 1970
NS Yokosuka (NAF Atsugi & Misawa)	05 Oct 1973‡

\* Temporary shore assignment while the squadron conducted training in preparation for combat deployment.

† On 30 June 1961 the squadron's home port was changed to NAS Moffett Field. However, the squadron did not arrive there until 8 December 1961.

‡ VA-115, along with CVW-5 and *Midway* (CVA 41), were part of a program to permanently assign a carrier and air wing to an overseas home port. *Midway's* new home port was Naval Station Yokosuka, Japan, and the squadron would normally operate out of NAF Atsugi or Misawa when the carrier was in NS Yokosuka. The assignment was effective 30 June 1973. However, the squadron did not arrive until 5 October 1973.

### Commanding Officers

<i>Date Assumed Command</i>	<i>Commanding Officer</i>
10 Oct 1942	LCDR Frederick L. Ashworth
25 Sep 1943	LCDR Radcliffe Denniston, Jr.
13 Nov 1944	LT Wilbur J. Engman (acting)
25 Dec 1944	LCDR John A. Fidel
12 Sep 1946	LT John W. Carmody
14 Oct 1946	LCDR George B. Riley
09 Jan 1948	LCDR Lawrence B. Green
14 Oct 1948	LCDR William H. House
16 Jan 1950	LCDR Richard W. Fleck
30 Jun 1951	CDR Charles H. Carr
08 Jul 1952	LCDR J. H. Sands (acting)
17 Sep 1952	LCDR J. M. Ritzdorf (acting)
18 Oct 1952	CDR J. D. Taylor
Jun 1954	CDR C. L. Dillard
May 1955	CDR C. W. Smith, Jr.
Mar 1957	CDR Leone E. Kirk, Jr.
04 Jun 1958	LCDR R. L. Bothwell
09 Oct 1959	CDR G. W. Gaiennie
27 Feb 1961	CDR J. F. Driscoll
15 Jan 1962	CDR C. H. Bowen
03 Jan 1963	CDR George A. Parker
21 Jan 1964	CDR Merrill C. Pinkepank
05 Aug 1964	CDR M. C. Cook (acting)
Oct 1964	CDR D. D. Smith
22 Jul 1965	CDR M. C. Cook
15 Jul 1966	CDR H. G. Bailey
Aug 1967*	CDR C. E. Hathaway
Jul 1968*	CDR O. E. Krueger
Jul 1969*	CDR R. H. Caldwell

**Commanding Officers—Continued**

	<i>Date Assumed Command</i>
CDR C. J. Ward	16 Jan 1970
CDR E. I. Carmichael	09 Jul 1971
CDR Paul D. Barrish	11 Jul 1972
CDR J. C. Presley	06 Jul 1973
CDR James J. Hower	12 Jun 1974
CDR Russell E. Whippes	22 Dec 1975
CDR Jay T. Grafton	28 Jan 1977
CDR Louis E. Thomassy	24 Feb 1978
CDR Rodney C. Franz	26 Jun 1979
CDR Joseph D. Favaro	01 Nov 1980
CDR Robert R. Wittenburg	21 Apr 1981
CDR William W. Radican	16 Jul 1982
CDR William A. Gouslin	27 Dec 1983
CDR Richard J. Rhoades	20 Jun 1985
CDR Paul D. Cash	19 Dec 1986
CDR David P. Polatty III	10 Jun 1988
CDR Terry J. Toms	Nov 1989
CDR James D. Kelly	01 Jul 1991

\* During the squadron's inactive period between August 1967 and January 1970 the squadron was under the administrative control of VA-125. The Commanding Officer of VA-125 was also the Commanding Officer of VA-115.

**Aircraft Assignment**

<i>Type of Aircraft</i>	<i>Date Type First Received</i>
TBF-1	Oct 1942
TBM-1	13 Oct 1943
TBM-1C	Nov 1943
TBM-3	19 Dec 1944
TBM-3E	Apr 1945
TBM-3Q	Jan 1947
TBM-3W	Oct 1947
AD-1	Dec 1948
AD-2	20 Dec 1948
AD-3Q	Aug 1949
AD-4	Dec 1949
AD-4Q	Jul 1950
AD-4L	May 1951
AD-4NA	Aug 1952
AD-6/A-1H*	Jan 1954
AD-7/A-1J*	Nov 1958
A-6A	03 Apr 1970
KA-6D	Feb 1971
A-6B	Oct 1973
A-6E	Apr 1977

\* The AD-6 and AD-7 designations were changed to A-1H and A-1J in 1962.



A photo of Manila harbor following an attack by squadron TBMs in November 1944.



Squadron TBM-3s on the deck of Valley Forge (CV 45) depart Portsmouth, England, during its world cruise in 1947–1948.

**Major Overseas Deployments**

<i>Date of Departure</i>	<i>Date of Return</i>	<i>Air Wing</i>	<i>Carrier</i>	<i>Type of Aircraft</i>	<i>Area of Operation</i>
Feb 1943	Jul 1943	CVG-11	*	TBF-1	SoPac
29 Sep 1944	01 Feb 1945	CVG-11	CV 12†	TBM-1C/3	Pacific
09 Oct 1947	11 Jun 1948	CVAG-11	CV 45‡	TBM-3E/Q/W	World Cruise
05 Jul 1950	07 Apr 1951	CVG-11	CV 47§	AD-4/4Q	WestPac/Korea
31 Dec 1951	08 Aug 1952	CVG-11	CV 47	AD-4/4L	WestPac/Korea
01 Jul 1953	18 Jan 1954	CVG-11	CVA 33	AD-4NA/4B	WestPac
07 Oct 1954	12 May 1955	CVG-11	CVA 33	AD-6	WestPac

**Major Overseas Deployments—Continued**

<i>Date of Departure</i>	<i>Date of Return</i>	<i>Air Wing</i>	<i>Carrier</i>	<i>Type of Aircraft</i>	<i>Area of Operation</i>
16 Jul 1956	26 Jan 1957	CVG-11	CVA 9	AD-6	WestPac
08 Mar 1958	22 Nov 1958	CVG-11	CVA 38	AD-6	WestPac
09 Mar 1959	03 Oct 1959	CVG-11	CVA 38	AD-7	WestPac
16 Jul 1960	18 Mar 1961	CVG-11	CVA 19	AD-7	WestPac
11 Aug 1961	01 Nov 1961	CVG-11	CVA 63	AD-6	++
13 Sep 1962	02 Apr 1963	CVG-11	CVA 63	A-1H/J	WestPac
17 Oct 1963	20 Jul 1964	CVW-11	CVA 63	A-1H/J	WestPac
19 Oct 1965	13 Jun 1966	CVW-11	CVA 63	A-1H/J	WestPac/Vietnam
05 Jan 1967	22 Jul 1967	CVW-5	CVA 19	A-1H	WestPac/Vietnam
16 Apr 1971	06 Nov 1971	CVW-5	CVA 41	A-6A/KA-6D	WestPac/Vietnam
10 Apr 1972	03 Mar 1973	CVW-5	CVA 41	A-6A/B & KA-6D	WestPac/Vietnam
11 Sep 1973	05 Oct 1973	CVW-5	CVA 41	A-6A/B & KA-6D	WestPac**
26 Nov 1973	22 Dec 1973	CVW-5	CVA 41	A-6A/B & KA-6D	WestPac
29 Jan 1974	06 Mar 1974	CVW-5	CVA 41	A-6A/B & KA-6D	WestPac
18 Oct 1974	20 Dec 1974	CVW-5	CVA 41	A-6A/B & KA-6D	WestPac
13 Jan 1975	18 Feb 1975	CVW-5	CVA 41	A-6A/B & KA-6D	WestPac
31 Mar 1975	29 May 1975	CVW-5	CVA 41	A-6A/B & KA-6D	WestPac
04 Oct 1975	19 Dec 1975	CVW-5	CV 41	A-6A/B & KA-6D	WestPac/IO
13 Mar 1976	26 Apr 1976	CVW-5	CV 41	A-6A/B & KA-6D	WestPac
19 May 1976	22 Jun 1976	CVW-5	CV 41	A-6A/B & KA-6D	WestPac
09 Jul 1976	04 Aug 1976	CVW-5	CV 41	A-6A/B & KA-6D	WestPac
01 Nov 1976	17 Dec 1976	CVW-5	CV 41	A-6A/B & KA-6D	WestPac
11 Jan 1977	01 Mar 1977	CVW-5	CV 41	A-6A/B & KA-6D	WestPac
19 Apr 1977	05 May 1977	CVW-5	CV 41	A-6A/B & KA-6D	WestPac††
08 Aug 1977	02 Sep 1977	CVW-5	CV 41	A-6E & KA-6D	WestPac
27 Sep 1977	21 Dec 1977	CVW-5	CV 41	A-6E & KA-6D	WestPac/IO
11 Apr 1978	23 May 1978	CVW-5	CV 41	A-6E & KA-6D	WestPac
09 Nov 1978	23 Dec 1978	CVW-5	CV 41	A-6E & KA-6D	WestPac
11 Jan 1979	20 Feb 1979	CVW-5	CV 41	A-6E & KA-6D	WestPac
07 Apr 1979	18 Jun 1979	CVW-5	CV 41	A-6E & KA-6D	IO
20 Aug 1979	14 Sep 1979	CVW-5	CV 41	A-6E & KA-6D	WestPac
30 Sep 1979	20 Feb 1980	CVW-5	CV 41	A-6E & KA-6D	IO
14 Jul 1980	26 Nov 1980	CVW-5	CV 41	A-6E & KA-6D	WestPac/IO
23 Feb 1981	05 Jun 1981	CVW-5	CV 41	A-6E & KA-6D	WestPac/IO
26 Jun 1981	16 Jul 1981	CVW-5	CV 41	A-6E & KA-6D	WestPac
03 Sep 1981	06 Oct 1981	CVW-5	CV 41	A-6E & KA-6D	WestPac
26 Apr 1982	18 Jun 1982	CVW-5	CV 41	A-6E & KA-6D	WestPac
14 Sep 1982	11 Dec 1982	CVW-5	CV 41	A-6E & KA-6D	NorPac/WestPac
02 Jun 1983	13 Aug 1983	CVW-5	CV 41	A-6E & KA-6D	WestPac
25 Oct 1983	11 Dec 1983	CVW-5	CV 41	A-6E & KA-6D	WestPac
28 Dec 1983	23 May 1984	CVW-5	CV 41	A-6E & KA-6D	IO
15 Oct 1984	12 Dec 1984	CVW-5	CV 41	A-6E & KA-6D	WestPac
01 Feb 1985	28 Mar 1985	CVW-5	CV 41	A-6E & KA-6D	WestPac
10 Jun 1985	4 Oct 1985	CVW-5	CV 41	A-6E & KA-6D	IO/WestPac
15 Nov 1985	12 Dec 1985	CVW-5	CV 41	A-6E & KA-6D	WestPac
17 Jan 1986	30 Mar 1986	CVW-5	CV 41	A-6E & KA-6D	WestPac
09 Jan 1987	20 Mar 1987	CVW-5	CV 41	A-6E & KA-6D	WestPac
23 Apr 1987	13 Jul 1987	CVW-5	CV 41	A-6/E & KA-6D	WestPac
15 Oct 1987	12 Apr 1988	CVW-5	CV 41	A-6E & KA-6D	WestPac/IO
18 Oct 1988	09 Nov 1988	CVW-5	CV 41	A-6E & KA-6D	WestPac
21 Jan 1989	24 Feb 1989	CVW-5	CV 41	A-6E & KA-6D	WestPac
27 Feb 1989	09 Apr 1989	CVW-5	CV 41	A-6E & KA-6D	WestPac
31 May 1989	25 Jul 1989	CVW-5	CV 41	A-6E & KA-6D	WestPac

**Major Overseas Deployments—Continued**

<i>Date of Departure</i>	<i>Date of Return</i>	<i>Air Wing</i>	<i>Carrier</i>	<i>Type of Aircraft</i>	<i>Area of Operation</i>
15 Aug 1989	11 Dec 1989	CVW-5	CV 41	A-6E & KA-6D	WestPac/IO
20 Feb 1990	06 Apr 1990	CVW-5	CV 41	A-6E & KA-6D	WestPac
02 Oct 1990	17 Apr 1991	CVW-5	CV 41	A-6E & KA-6D	WestPac/IO/ Persian Gulf

\* The squadron was landbased during its operations in the South Pacific.

† The squadron transferred to *Kasaan Bay* (CVE 69) on 1 February 1945 at Ulithi for transport back to Hawaii, it then boarded Curtiss (AV 4) for transportation to the States.

‡ During October through December 1947 the squadron operated from NAS Barbers Point with occasional exercises aboard *Valley Forge* (CV 45). In January 1948 the squadron departed NAS Barbers Point, embarked in *Valley Forge*, continuing its world cruise.

§ While docked at Yokosuka, Japan, the squadron transferred from *Philippine Sea* (CV 47) to *Valley Forge* (CV 45) on 29 March 1951 for its return trip to the U.S. *Philippine Sea* continued its tour of duty in Korea with another air group.

++ The squadron operated from *Kitty Hawk* (CVA 63) during its home port change from the Atlantic to the Pacific. The transit to the Pacific, via Cape Horn, was part of a training cruise that included operations in the Caribbean, South Atlantic and eastern Pacific.

\*\* The squadron and *Midway* (CVA 41) arrived at their new home port, Naval Station Yokosuka, Japan. Since the squadron is permanently forward deployed all future deployments for the squadron will cover only those operations outside the home waters of Japan.

†† The squadron exchanged its A-6A and B model Intruders for A-6Es while *Midway* was in port at NS Subic Bay. Transitional training in the A-6E was conducted from NAF Atsugi during May to August 1977.



*Squadron AD-4 Skyraiders prepare to launch a strike from Philippine Sea (CV 47) during their first combat deployment to Korea, circa September 1950.*

### Air Wing Assignments

<i>Air Wing</i>	<i>Tail Code</i>	<i>Assignment Date</i>
CVG-11/CVAG-11/ CVG-11/CVW-11†	V/NH*	10 Oct 1942
CVW-5	NF	16 Jul 1966
VA-125‡		Aug 1967
CVW-16	AH	1970
CVW-5	NF	1971

\* The tail code V was assigned to CVG-11 on 7 November 1946. The tail code was changed from V to NH in 1957. The effective date for this change was most likely the beginning of FY 58 (1 July 1957).

† CVG-11 was redesignated CVAG-11 on 15 November 1946. The CVAG-11 designation was changed back to CVG-11 on 1 September 1948. CVG-11 was redesignated CVW-11 when Carrier Air Group (CVG) designations were redesignated Carrier Air Wings (CVW) on 20 December 1963.

‡ Administratively assigned to VA-125 during the squadron's stand-down.



*A flight of squadron A-1H Skyraiders, circa 1964.*

### Unit Awards Received

<i>Unit Award</i>	<i>Inclusive Dates Covering Unit Award</i>	
PUC	10 Oct 1944	22 Nov 1944
	14 Dec 1944	16 Dec 1944
	03 Jan 1945	22 Jan 1945
	30 Apr 1972	09 Feb 1973

### Unit Awards Received—Continued

<i>Unit Award</i>	<i>Inclusive Dates Covering Unit Award</i>	
Campaign Medal (Asiatic-Pacific)	08 Feb 1943	20 Jun 1943
	10 Oct 1944	29 Nov 1944
	14 Dec 1944	
	09 Jan 1945	



*A flight of two squadron A-6E Intruders loaded with cluster bombs, 1991.*

**Unit Awards Received—Continued**

<i>Unit Award</i>	<i>Inclusive Dates Covering Unit Award</i>	
	12 Jan 1945	
	16 Jan 1945	
KPUC	01 Aug 1950	16 Mar 1951
	20 Jan 1952	12 Jul 1952
NUC	04 Aug 1950	16 Mar 1951
	26 Nov 1965	14 May 1966
	29 Apr 1975	30 Apr 1975
	01 Jan 1978	30 Jun 1979
	17 Jan 1991	07 Feb 1991
SASM	02 Nov 1990	14 Mar 1991
KLM	17 Jan 1991	28 Feb 1991
NAVE	01 Jul 1959	30 Jun 1960
	01 Jul 1961	Oct 1962
	Nov 1962	Feb 1964
	01 Jul 1977	31 Dec 1978
	01 Jan 1978	30 Jun 1980
AFEM	20 May 1964	10 Jun 1964
	17 Oct 1971	19 Oct 1971
	29 Apr 1975	30 Apr 1975
HSM	29 Apr 1975	30 Apr 1975
MUC	20 Jan 1967	14 Jul 1967
	07 May 1971	28 Oct 1971
	13 Nov 1979	08 Feb 1980
	27 Jul 1982	01 May 1984
	15 Oct 1989	29 Oct 1989
NEM	15 Apr 1979	06 Jun 1979

**Unit Awards Received—Continued**

<i>Unit Award</i>	<i>Inclusive Dates Covering Unit Award</i>	
	21 Nov 1979	07 Feb 1980
	19 Aug 1980	13 Nov 1980
	12 Mar 1981	19 May 1981
RVNGC	30 Mar 1972	15 Jul 1972
VNSM	25 Nov 1965	23 Dec 1965
	15 Jan 1966	04 Feb 1966
	18 Feb 1966	14 Mar 1966
	01 Apr 1966	29 Apr 1966
	08 May 1966	23 May 1966
	05 Feb 1967	25 Feb 1967
	15 Mar 1967	12 Apr 1967
	28 Apr 1967	04 Jun 1967
	12 Jun 1967	27 Jun 1967
	17 May 1971	09 Jun 1971
	29 Jun 1971	20 Jul 1971
	31 Jul 1971	17 Aug 1971
	26 Sep 1971	11 Oct 1971
	01 May 1972	01 Jun 1972
	11 Jun 1972	07 Jul 1972
	16 Jul 1972	13 Aug 1972
	23 Aug 1972	10 Sep 1972
	19 Sep 1972	12 Oct 1972
	23 Oct 1972	23 Nov 1972
	03 Dec 1972	22 Dec 1972
	31 Dec 1972	
	04 Jan 1973	24 Jan 1973
	03 Feb 1973	09 Feb 1973

## VA-122

### Lineage

Established as Composite Squadron THIRTY FIVE (VC-35) on 25 May 1950.

Redesignated Attack Squadron (All Weather) THIRTY FIVE (VA(AW)-35) on 1 July 1956.

Redesignated Attack Squadron ONE TWENTY TWO (VA-122) on 29 June 1959.

Disestablished on 31 May 1991. The first squadron to be assigned the VA-122 designation.

### Squadron Insignia and Nickname

The squadron's first insignia was approved by CNO on 13 September 1951. Colors for the owl insignia



*The owl design was the squadron's first approved insignia.*

were: a red background with a blue and white owl, the eyes of the owl were gold.

Following the redesignation to VA-122 the squadron requested approval for a new insignia. The new insignia was approved by CNO on 22 April 1960. The colors of the eagle and book insignia were: a blue background for the insignia and scroll, out-

lined in black; a white wreath; the book had black pages, edged in white with a red cover; brown eagle with black highlights, its head was white with black highlights and a yellow beak and claws; a white bomb outlined in black with three red bands; and the scroll's lettering was white.

Nickname: Flying Eagles, 1971–1991.



*The squadron's second insignia highlights its mission as a fleet replacement training squadron.*

### Chronology of Significant Events

May 1950: The squadron was established with a mission of all-weather attack and ASW. The squadron trained detachments for carrier deployments and also participated in various exercises held on the west coast.

9 Nov 1950–9 Jun 1951: VC-35 Det 3 was the squadron's first detachment to deploy. It deployed to Korea and flew ASW patrols, night heckler missions, and other combat sorties. These became the standard

missions for the squadron detachments that deployed to Korea.

29 Jun 1959: The squadron's mission was changed from all-weather attack to fleet replacement training. It was responsible for instrument flight training for fleet prop pilots, including ground school; enlisted ground training for Skyraider maintenance personnel; and the training of fleet replacement pilots for the AD-6/7 Skyraider.

Jun–Aug 1960: The squadron trained eight officers from the South Vietnamese Air Force in the operation of the AD Skyraider.

Nov 1966: With the acceptance of the A-7A Corsair II, the squadron took on the additional mission of fleet replacement training in this new aircraft.

1967: VA-147 was the first squadron to be trained in the A-7 by VA-122.

Dec 1969: The squadron joined with VA-125 to inaugurate a graduate level Light Attack Weapons School which involved three intensive weeks of classroom and flight syllabus training covering all phases of attack aviation.

15 Oct 1973: VA-122's Weapons Training Center, which conducted the Light Attack Weapons School, became a separate command and was designated Light Attack Weapons School, Pacific.

30 Jun 1988: With the disestablishment of VA-174 the east coast Fleet Readiness Squadron for the A-7, VA-122 assumed the responsibility for A-7 training on both coasts.

May 1991: Prior to VA-122's disestablishment, it had trained and graduated over 5,000 light attack pilots and over 55,000 highly skilled maintenance personnel during its career as a fleet replacement training squadron.

### Home Port Assignments

	<i>Location Assignment Date</i>
NAS San Diego/North Island*	25 May 1950
NAS Moffett Field	01 Jul 1961
NAS Lemoore	01 Jan 1963

\* NAS San Diego was redesignated NAS North Island in 1955.



*Squadron AD-4NL Sky-raidiers in flight, 6 October 1951 (Courtesy Robert Lawson Collection).*

**Commanding Officers**

	<i>Date Assumed Command</i>
CDR Charles R. Stapler	25 May 1950
CDR David A. Marks	19 May 1951
CDR William L. Conley (acting)	25 Aug 1951
CDR David A. Marks	29 Nov 1951
CDR Louis E. Burke, Jr.	31 Jul 1952
CDR Frank G. Edwards (acting)	31 Oct 1952
CDR Louis E. Burke, Jr.	25 Nov 1952
CDR John H. Pennoyer	Apr 1953
CDR Guiseppi Macri	16 Sep 1955
CDR Donald B. Ingerslew	Jan 1956
CAPT Edward V. Wedell	09 Aug 1957
CAPT L. E. Harris	29 Jul 1959
CDR P. E. Payne	26 Jul 1960
CDR J. A. Davenport	23 Jun 1961
CDR John E. Ford	19 Oct 1962
CDR Joseph L. Coleman	08 Nov 1963
CDR M. C. Pinkepank	10 Aug 1964
CDR Hugh A. Hoy	06 Oct 1965
CDR Melvin D. Blixt	11 Oct 1966
CDR Carl Birdwell, Jr.	Jul 1967
CDR Melvin M. Quaid, Jr.	23 Aug 1968
CDR Walter S. Gray III	29 Aug 1969
CDR John L. Nicholson, Jr.	07 Aug 1970
CDR Jesse R. Emerson III	10 Aug 1971
CDR Cecil B. Hawkins, Jr.	08 Aug 1972
CAPT Robert N. Livingston	30 Nov 1973
CDR Richard L. Grant	07 Feb 1975
CDR Kenneth A. Dickerson	16 Apr 1976
CDR Meredith W. Patrick	19 Aug 1977
CDR John A. Moriarty	06 Dec 1978
CDR Lawrence H. Price	20 May 1980
CDR Howard E. Koss	09 Sep 1981
CDR John E. Vomastic	05 Apr 1983
CDR William S. Orr, Jr.	01 Jun 1984
CDR Thomas R. Mitchell III	11 Sep 1985

**Commanding Officers—Continued**

	<i>Date Assumed Command</i>
CDR Russell C. York	17 Dec 1986
CDR George Crim	15 Mar 1988
CAPT Jeffery Harrison	14 Jul 1989

**Aircraft Assignment**

<i>Type of Aircraft</i>	<i>Date Type First Received</i>
AD-4N	Jun 1950
AD-3Q	Jun 1950
AD-4Q	Jul 1950
AD-2Q	Jul 1950
AD-3	Jul 1950
TBM-3E/N	Jul 1950
AD-1Q	Aug 1950
AD-3N	Dec 1950
AD-4NL	Aug 1951
AD-4N	Jan 1952
AD-4B	Feb 1952
F3D-2	Feb 1953
AD-5N	Mar 1954
AD-5/A-1E*	May 1954
AD-6/A-1H*	May 1954
S2F-1	Oct 1956
TF-1Q	18 Jan 1957
AD-5Q	20 Nov 1957
AD-7/A-1J*	05 Dec 1958
T-28B	01 Mar 1959
A-7A	15 Nov 1966
A-7B	May 1968
A-7E	14 Jul 1969
A-7C	Jul 1971
T-39D	1971
T-28C	1973
TA-7C	1978

\* AD-5/6/7 designations were changed to A-1E/H/J in 1962.

**Major Overseas Deployments**

<i>Date of Departure</i>	<i>Date of Return</i>	<i>Air Wing</i>	<i>Carrier</i>	<i>Det*</i>	<i>Type of Aircraft</i>	<i>Area of Operation</i>
09 Nov 1950	09 Jun 1951	CVG-19	CV 37	3	AD-4N	Korea
06 Dec 1950	09 Jun 1951	CVG-2	†	4	AD-4N	Korea
02 Mar 1951	24 Oct 1951	CVG-101	CV 21	5/A	AD-2/4N & 4Q	Korea
10 May 1951	17 Dec 1951	CVG-102	CV 31	6/G	AD-3/4N	Korea
May 1951	29 Aug 1951	CVG-19X	‡	7	AD-4N	Korea
26 Jun 1951	25 Mar 1952	CVG-5	CV 9	8/B	AD-2, AD-3, N/Q, AD-4, L/Q & AD-4NL	Korea
08 Sep 1951	02 May 1952	CVG-15	CV 36	9/D	AD-4NL/4Q	Korea
15 Oct 1951	03 Jul 1952	ATG-1	CV 45	10/H	AD-4NL & AD-2Q	Korea
31 Dec 1951	08 Aug 1952	CVG-11	CV 47	C	AD-4NL/Q & 2Q	Korea



**Major Overseas Deployments—Continued**

<i>Date of Departure</i>	<i>Date of Return</i>	<i>Air Wing</i>	<i>Carrier</i>	<i>Det*</i>	<i>Type of Aircraft</i>	<i>Area of Operation</i>
08 Feb 1952	25 Sep 1952	CVG-2	CV 21	A	AD-4N/2Q/3N/4NL	Korea
21 Mar 1952	03 Nov 1952	CVG-19	CV 37	E	AD-4NL/4Q & 3Q	Korea
16 Jun 1952	06 Feb 1953	ATG-2	CVA 9	I	AD-4N	Korea/WestPac
16 Jun 1952	Sep 1953	§	§	W	AD-4B/NL/N	WestPac
11 Aug 1952	17 Mar 1953	CVG-101	CVA 33	F	AD-4N/NL	Korea
15 Sep 1952	18 May 1953	CVG-102	CVA 34	G	AD-4N	Korea
20 Nov 1952	25 Jun 1953	CVG-5	CVA 45	B	AD-4N	Korea
15 Dec 1952	14 Aug 1953	CVG-9	CVA 47	M	AD-4N	Korea
24 Jan 1953	21 Sep 1953	CVG-15	CVA 37	D	AD-4N	Korea/WestPac
30 Mar 1953	28 Nov 1953	ATG-1	CVA 21	H	AD-4N	Korea/WestPac
01 Jul 1953	18 Jan 1954	CVG-11	CVA 33	C	AD-4N	Korea/WestPac
03 Aug 1953	03 Mar 1954	CVG-2	CVA 10	A	AD-4N	WestPac
14 Sep 1953	22 Apr 1954	CVG-19	CVA 34	E	AD-4N	WestPac
01 Dec 1953	12 Jul 1954	ATG-2	CVA 9	I	AD-4N	WestPac
03 Mar 1954	11 Oct 1954	CVG-12	CVA 21	G	AD-4NL	WestPac
12 Mar 1954	19 Nov 1954	CVG-5	CVA 47	B	AD-4NL	WestPac
11 May 1954	12 Dec 1954	CVG-9	CVA 12	M	AD-4N	World Cruise
01 Jul 1954	28 Feb 1955	CVG-15	CVA 10	D	AD-4N	WestPac
01 Sep 1954	11 Apr 1955	ATG-1	CVA 18	H	AD-4N	WestPac
07 Oct 1954	12 May 1955	CVG-11	CVA 33	C	AD-5N	WestPac
03 Nov 1954	21 Jun 1955	CVG-2	CVA 9	A	AD-5N	WestPac
02 Mar 1955	21 Sep 1955	CVG-19	CVA 34	E	AD-5N	WestPac
01 Apr 1955	23 Nov 1955	ATG-2	CVA 47	I	AD-5N	WestPac
03 Jun 1955	03 Feb 1956	CVG-14	CVA 21	F	AD-5N	WestPac
10 Aug 1955	15 Mar 1956	CVG-12	CVA 19	G	AD-5N	WestPac
29 Oct 1955	17 May 1956	CVG-5	CVA 33	B	AD-5N	WestPac
05 Jan 1956	23 Jun 1956	ATG-3	CVA 38	J	AD-5N	WestPac
11 Feb 1956	13 Jun 1956	CVG-9	CVA 34	M	AD-5N	WestPac
19 Mar 1956	13 Sep 1956	ATG-4	CVA 10	K	AD-5N	WestPac
23 Apr 1956	15 Oct 1956	CVG-15	CVA 18	D	AD-5N	WestPac
28 May 1956	20 Dec 1956	ATG-1	CVA 16	H	AD-5N	WestPac
16 Jul 1956	26 Jan 1957	CVG-11	CVA 9	C	AD-5N	WestPac
16 Aug 1956	28 Feb 1957	CVG-21	CVA 31	L	AD-5N	WestPac
13 Nov 1956	20 May 1957	CVG-2	CVA 38	A	AD-5N	WestPac
21 Jan 1957	25 Jul 1957	CVG-14	CVA 12	F	AD-5N	WestPac
09 Mar 1957	25 Aug 1957	CVG-19	CVA 10	E	AD-5N	WestPac
06 Apr 1967	18 Sep 1957	ATG-2	CVA 19	I	AD-5N	WestPac
19 Apr 1957	17 Oct 1957	CVG-12	CVA 16	G	AD-5N	WestPac
10 Jul 1957	11 Dec 1957	CVG-5	CVA 31	B	AD-5N	WestPac
09 Aug 1957	02 Apr 1958	ATG-3	CVA 33	J	AD-5N	WestPac
16 Sep 1957	25 Apr 1958	CVG-9	CVA 14	M	AD-5N	WestPac
06 Jan 1958	30 Jun 1958	ATG-4	CVA 12	K	AD-5N	WestPac
15 Feb 1958	02 Oct 1958	CVG-15	CVA 19	D	AD-5N	WestPac
08 Mar 1958	21 Nov 1958	CVG-11	CVA 38	C	AD-5N	WestPac
14 Jul 1958	19 Dec 1958	CVG-21	CVA 16	L	AD-5N	WestPac
16 Aug 1958	12 Mar 1959	CVG-2	CVA 41	A	AD-5N	WestPac
21 Aug 1958	12 Jan 1959	ATG-4	CVA 20	K	AD-5N	WestPac
04 Oct 1958	17 Feb 1959	ATG-1	CVA 14	H	AD-5N	WestPac
01 Nov 1958	18 Jun 1959	CVG-19	CVA 31	E	AD-5N	WestPac

**Major Overseas Deployments—Continued**

<i>Date of Departure</i>	<i>Date of Return</i>	<i>Air Wing</i>	<i>Carrier</i>	<i>Det*</i>	<i>Type of Aircraft</i>	<i>Area of Operation</i>
03 Jan 1959	27 Jul 1959	CVG-14	CVA 61	F	AD-5N	WestPac
09 Mar 1959	02 Oct 1959	CVG-11	CVA 38	C	AD-5N	WestPac
26 Apr 1959	02 Dec 1959	CVG-21	CVA 16	L**	AD-5N	WestPac

\* The squadron only deployed in detachments, usually four aircraft, and never as a complete squadron. In October 1951 the squadron's detachment designations were changed from numbers to letters.

† Detachment 4 deployed to Korea embarked in *Valley Forge* (CV 45) and on 29 March 1951, as part of CVG-2, transferred to *Philippine Sea* (CV 47). It returned to the States embarked in *Philippine Sea*.

‡ The detachment was sent to Japan, via air and ship transport, as part of Replacement Air Group 19X (CVG-19X). When it arrived in Japan it relieved CVG-19 in *Princeton* (CV 37). Upon completion of its combat tour in Korea it returned to the States embarked in *Princeton*.

§ VC-35 Det W deployed to NAS Atsugi, Japan. The detachment departed for NAS Atsugi embarked in *Essex* (CV 9) and arrived there in the latter part of July 1952. While deployed to Japan, VC-35 Det W was under the operational control of COMFAIRJAPAN (Commander Fleet Air, Japan).

\*\* VA(AW)-35 Det L was the squadron's last detachment to deploy prior to the squadron's change of mission to training fleet replacement pilots and enlisted men and the phase out of its all-weather attack mission.



*A squadron TF-1, circa 1957 (Courtesy Duane Kasulka Collection).*

### Air Wing Assignments

<i>Air Wing</i>	<i>Tail Code</i>	<i>Assignment Date</i>
COMAIRPAC	NR*/VV†	
RCVG-12/RCVW-12‡	NJ	29 Jun 1959
COMFAIRLEMOORE	NJ§	01 Jul 1970
COMLATWINGPAC**	NJ	30 Jun 1973

\* The tail code NR was assigned to VC-35 by Aviation Circular Letter No. 43-50 dated 19 July 1950.

† The tail code was changed from NR to VV in 1957. The effective date for this change was most likely the beginning of FY 58 (1 July 1957).

‡ Replacement Air Group 12 (RCVG-12) was redesignated Combat Readiness Air Group 12 (RCVW-12) on 1 April 1963. Combat

Readiness Air Group 12 was then redesignated Combat Readiness Air Wing 12 (RCVW-12) on 20 December 1963.

§ RCVW-12 was disestablished on 1 July 1970 and the squadron was assigned to Commander Fleet Air Lemoore. However, the tail code NJ, which had been assigned to RCVW-12, was retained by VA-122 and the other squadrons that had been assigned to RCVW-12.

\*\* COMFAIRLEMOORE was redesignated COMLATWINGPAC (Commander Light Attack Wing, Pacific) on 30 June 1973.

### Unit Awards Received

<i>Unit Award</i>	<i>Inclusive Dates Covering Unit Award</i>	
MUC	01 Jul 1970	31 Jul 1971
	01 Oct 1978	30 Sep 1980



*A formation of the squadron's A-7E Corsair II aircraft over the Sierras.*

## VA-125

### Lineage

Reserve Attack Squadron FIFTY FIVE E (VA-55E) was most likely established during the activation of the Naval Air Reserve in 1946 and remained in an inactive status.

Redesignated Reserve Attack Squadron NINE HUNDRED TWENTY THREE (VA-923) in January 1950.

Reserve Attack Squadron NINE HUNDRED TWENTY THREE (VA-923) was called to active duty on 20 July 1950.

Redesignated Attack Squadron ONE HUNDRED TWENTY FIVE (VA-125) on 4 February 1953.

Disestablished on 10 April 1958. The first squadron to be assigned the VA-125 designation.



*This insignia was used by the squadron during its deployment to Korea in 1952–1953 aboard Oriskany (CVA 34).*

### Squadron Insignia and Nickname

There is no record for an approved squadron insignia. However, an insignia was used by the squadron during its deployment aboard *Oriskany* (CVA 34) in 1952–1953. There are no colors available for this insignia. The Latin phrase *Mors ab Alto* means Death from Above.

Nickname: Rough Raiders, 1952–1958.

### Chronology of Significant Events

**1 Feb 1953:** The squadron's commanding officer, Commander J. C. Micheel was killed in action in Korea.

### Home Port Assignments

<i>Location</i>	<i>Assignment Date</i>
NAS St. Louis	*
NAS San Diego	02 Aug 1950
NAS Miramar	Jan 1952

\* The squadron's home port was assigned prior to 1950, the exact date is unknown.

### Commanding Officers

	<i>Date Assumed Command</i>
LCDR Herb W. Wiley	*
CDR John C. Micheel	24 Mar 1952
LCDR Allan H. Gunderson	01 Feb 1953
LCDR John L. McMahon, Jr.	Jul 1953
LCDR Bernard E. Hackett	Oct 1954
CDR John H. Bahlman	Apr 1956
CDR A. J. Henry, Jr.	25 Oct 1957

\* Assumed command prior to 1950, date unknown.

### Aircraft Assignment

<i>Type of Aircraft</i>	<i>Date Type First Received</i>
TBM	*
AM	1950
AD-2	Sep 1950
AD-4Q	Oct 1950
AD-4	Dec 1950
AD-3	Dec 1950
AD-4B	Jun 1953
AD-4NA	Sep 1953
AD-6	Oct 1954
AD-7	Jan 1957

\* The squadron was assigned the TBM prior to 1950, date unknown.

*A squadron AM-1 Mauler flown by VA-923. Pilot in photo is Hank Gastrich; it was taken following his landing in the plane in which a gauge indicated the wings were unlocked during flight, circa 1950 (Courtesy Steve Ginter Collection).*



**Major Overseas Deployments**

<i>Date of Departure</i>	<i>Date of Return</i>	<i>Air Wing</i>	<i>Carrier</i>	<i>Type of Aircraft</i>	<i>Area of Operation</i>
10 May 1951	17 Dec 1951	CVG-102	CV 31	AD-3/4Q	Korea
15 Sep 1952	18 May 1953	CVG-102	CVA 34	AD-3/4	Korea
03 Mar 1954	11 Oct 1954	CVG-12	CVA 21	AD-4B/NA	WestPac
10 Aug 1955	15 Mar 1956	CVG-12	CVA 19	AD-6	WestPac
19 Apr 1957	17 Oct 1957	CVG-12	CVA 16	AD-6/7	WestPac



*A squadron AD-3 or 4 takes off from Bon Homme Richard (CV 31) during their combat deployment to Korea in 1951.*

**Air Wing Assignments**

<i>Air Wing</i>	<i>Tail Code</i>	<i>Assignment Date</i>
CVG-102/CVG-12†	D/NJ‡	1950*

\* VA-923's assignment to CVG-102 was in August or September 1950.  
 † CVG-102 was redesignated CVG-12 on 4 February 1953.  
 ‡ The tail code was changed from D to NJ in 1957. The effective date for this change was most likely the beginning of FY 58 (1 July 1957).

**Unit Awards Received**

<i>Unit Award</i>	<i>Inclusive Dates Covering Unit Award</i>	
KSM	30 May 1951	06 Dec 1951
	17 Oct 1952	29 Oct 1952
	31 Oct 1952	29 Mar 1953
	27 Apr 1953	02 May 1953

*A squadron AD Skyraider prepares to launch from Hancock (CVA 19) during its cruise to WestPac in 1955-1956.*



## SECOND VA-125

### Lineage

Established as Attack Squadron TWENTY SIX (VA-26) on 30 June 1956.

Redesignated Attack Squadron ONE HUNDRED TWENTY FIVE (VA-125) on 11 April 1958.

Disestablished on 1 October 1977. The second squadron to be assigned the designation VA-125.



*The tiger head was the squadron's first insignia.*

was brown and white with black markings; the lightning bolt whiskers were yellow and outlined in black; the tongue and inside of the mouth were red.

When the squadron's mission was changed, a new insignia was approved by CNO on 13 May 1959. Colors for the torch of learning insignia are unknown.

Nickname: Skylancers, 1956–1958

Rough Raiders, 1958–1977.

### Chronology of Significant Events

**11 Apr 1958:** The squadron's mission was changed from air-to-ground/surface attack to the indoctrination and training of pilots and enlisted personnel in attack aircraft for assignment to combat carrier squadrons.

**11 Dec 1958:** The squadron's commanding officer, Commander J. E. Thomas, was killed in an aircraft accident.

**Mar 1960:** With the addition of the A4D-2N Skyhawk, the squadron added radar and inflight refueling training to its flight syllabus.

### Squadron Insignia and Nickname

The squadron's first insignia was approved by CNO on 18 December 1956. Colors for the cougar insignia were: a dark blue background outlined in black; white scroll outlined in black with black lettering; white stars; the cougar's face



*When the squadron's mission changed to fleet replacement training, this insignia was adopted and approved for used by the squadron.*

**19 May 1966:** VA-125 was the first squadron in the Navy to receive the TA-4F Skyhawk.

**Jun 1966:** The first of several groups of Australians arrived for training by the squadron on the A-4 Skyhawk. The pilots were to form the nucleus of Australia's first A-4 squadron scheduled for assignment to HMAS *Melborne* (R-21).

**13 Mar 1967:** The squadron's commanding officer, Commander J. D. Shaw, was killed in an aircraft accident during a routine carrier qualification exercise on the *Kearsarge* (CVS 33).

**31 Mar 1969:** The last A-4 Fleet Replacement Pilot class began.

**30 Jun 1969:** The last A-4 Fleet Replacement Enlisted Maintenance training program was completed.

**Nov 1969:** The squadron began to develop the required training program for the Light Attack Weapons School. In December 1969 the squadron, in conjunction with VA-122, inaugurated a graduate level course for the Light Attack Weapons School that involved all phases of attack aviation.

**Jan 1970:** The first A-7 Fleet Replacement Enlisted Maintenance and Fleet Replacement Pilot classes began.



*A formation of squadron F9F-8 Cougars, circa 1957.*

### Home Port Assignments

<i>Location</i>	<i>Assignment Date</i>
NAS Miramar	30 Jun 1956
NAS Moffett Field	Aug 1956
NAS Lemoore	24 Jul 1961

### Commanding Officers

	<i>Date Assumed Command</i>
CDR Richard D. Greer, Jr.	30 Jun 1956
CDR C. H. Carr	11 Apr 1958
CDR J. E. Thomas	15 Jul 1958
CDR F. E. Ward, Jr.	11 Dec 1958

**Commanding Officers—Continued**

	<i>Date Assumed Command</i>
CDR P. H. Durand	30 Nov 1959
CDR O. L. Dauphin	05 Apr 1961
CDR James W. Porter	09 Apr 1962
CDR Earl F. Godfrey	29 May 1963
CDR William J. Forgy	14 Sep 1964
CDR Jack A. Endacott	27 Aug 1965
CDR John D. Shaw	29 Jul 1966
CDR Gary H. Palmer (acting)	13 Mar 1967
CDR Charles E. Hathaway	12 May 1967
CDR Otto E. Krueger	11 Jul 1968
CDR Ronald H. Caldwell	31 Jul 1969
CDR George E. LeBlanc, Jr.	31 Jul 1970
CDR James B. Busey IV	10 May 1971
CDR James M. Gleim	31 Mar 1972
CDR Charles R. Bowling	06 Jul 1973
CDR Robert C. Taylor	12 Sep 1974
CDR Denis R. Weichman	17 Dec 1975
CDR J. W. Keathley	28 Mar 1977

**Aircraft Assignment**

<i>Type of Aircraft</i>	<i>Date Type First Received</i>
F9F-8B	Jul 1956
F9F-8	Oct 1956
A4D-1	10 Jun 1958
A4D-2/A-4B*	Aug 1958
A4D-2N/A-4C*	03 Mar 1960
AD-5/A-1E*	Sep 1960
A-4E	Dec 1962
TA-4F	19 May 1966
A-4F	Feb 1968
A-7B	25 Sep 1969
A-7A	Oct 1969
A-7C	Aug 1975

\* The A4D-2, A4D-2N and AD-5 designations were changed to A-4B, A-4C and A-1E in 1962.



A close up of an F9F-8 Cougar with squadron personnel, taken during the squadron's 1957–1958 deployment to WestPac aboard *Kearsarge* (CVA

**Major Overseas Deployments**

<i>Date of Departure</i>	<i>Date of Return</i>	<i>Air Wing</i>	<i>Carrier</i>	<i>Type of Aircraft</i>	<i>Area of Operation</i>
09 Aug 1957	02 Apr 1958	ATG-3	CVA 33*	F9F-8	WestPac

\* During the deployment aboard *Kearsarge* (CVA 33) the squadron was based at NAS Agana, Guam, for a considerable part of the cruise.



*A formation of five different models of the A-4 Skyhawk flown by the squadron in 1969; the A-4B, A-4C, A-4E, A-4F and TA-4F.*

### **Air Wing Assignments**

<i>Air Wing</i>	<i>Tail Code</i>	<i>Assignment Date</i>
ATG-3	Y/NC*	30 Jun 1956
RCVG-12/RCVW-12†	NJ	11 Apr 1958
COMFAIRLEMOORE	NJ‡	01 Jul 1970
COMLATWINGPAC§	NJ	30 Jun 1973

\* The tail code was changed from Y to NC in 1957. The effective date for this change was most likely the beginning of FY 58 (1 July 1957).

† The Replacement Air Group designation (RCVG) was changed to Combat Readiness Air Group (RCVG) on 1 April 1963 and then to Combat Readiness Air Wing (RCVW) on 20 December 1963.

‡ RCVW-12 was disestablished on 1 July 1970 and the squadron was assigned to Commander Fleet Air Lemoore. However, the tailcode NJ, which had been assigned RCVW-12, was retained by VA-125 and the other squadrons that had been assigned to RCVW-12.

§ COMFAIRLEMOORE was redesignated COMLATWINGPAC (Commander Light Attack Wing, Pacific) on 30 June 1973.



*A squadron A-1E Skyraider, 1965 or 1966.*

*A formation of squadron A-7 Corsair IIs over NAS Lemoore, California, 1970.*





## VA-128

### Lineage

Established as Attack Squadron ONE HUNDRED TWENTY EIGHT (VA-128) on 1 September 1967. The first squadron to be assigned the VA-128 designation.



The stylized phoenix insignia used by the squadron.

### Squadron Insignia and Nickname

The squadron's insignia was approved by CNO on 9 August 1967. Colors for the stylized Phoenix insignia are: white background for insignia and scroll, outlined in gold; the stylized Phoenix and the lettering are also gold.

Nickname: Golden Intruders, 1967-present

### Chronology of Significant Events

**1 Sep 1967:** The squadron was assigned the mission of training combat ready flight crews and replacement maintenance personnel for the A-6 Intruder.

**Oct 1968:** Two U.S. Air Force exchange officers reported aboard for training in the A-6A.

**Jun 1973:** A Naval Officer from the Federal Republic of Germany reported aboard for training in the A-6.

**Mar–May 1980:** The squadron's TC-4C, Target Recognition Attack Multisensor (TRAM) equipped aircraft, was used to monitor the hot spots on Mt. St. Helens in Washington prior to a major eruption on 18 May. The squadron's work with U.S. Geological Survey

authorities provided the forewarning necessary to save hundreds of lives since the mountain was a popular place for campers, boaters and mountain climbers.

**Oct 1986:** The squadron assumed the additional duty of training all Marine Corps personnel on the A-6 following the disestablishment of VMAT(AW)-202.

**1990:** The squadron received the first composite wing A-6E on the West Coast.

### Home Port Assignments

Location	Assignment Date
NAS Whidbey Island	01 Sep 1967

### Commanding Officers

	Date Assumed Command
CDR W. B. Warwick	01 Sep 1967
CDR N. R. Gooding, Jr.	16 May 1969
CDR Leland S. Kollmorgen	26 Jun 1970
CDR Lester W. Berglund	1971
CDR Robert W. Miles	07 Jul 1972
CDR Richard M. Dunleavy	03 Aug 1973
CDR George E. Matt	17 Oct 1974
CDR Robert S. Owens	12 Dec 1975
CDR Van F. Westfall	01 Nov 1976
CDR Lyle F. Bull	03 Feb 1978
CDR Daryl L. Kerr	29 Jun 1979
CDR John M. McNabb	01 Aug 1980
CDR Rodney C. Franz	10 Jul 1981
CDR David D. Williams	15 Oct 1982
CDR Patrick C. Hauert	06 Jan 1984
CDR Robert R. Whittenburg	1985
CDR Bruce V. Wood	24 Oct 1986
CDR Kenneth G. Bixler	22 Jan 1988
CDR Gary W. Stubbs	30 Jun 1989
CDR Michael J. McCamish	17 Aug 1990



Squadron A-6E Intruders conducting aerial refueling, 1982.

### Aircraft Assignment

<i>Type of Aircraft</i>	<i>Date Type First Received</i>
A-6A	01 Sep 1967
TC-4C	15 Mar 1968
A-6E	16 Dec 1973

\* RCVW-12 was disestablished on 1 July 1970 and the squadron was assigned to Commander Fleet Air Whidbey. However, the tail code NJ, which had been assigned to RCVW-12, was retained by VA-128 and the other squadrons that had been assigned to RCVW-12.

† Commander Fleet Air Whidbey was redesignated Commander Medium Attack Tactical Electronic Warfare Wing Pacific (COMMATVAQWINGPAC) on 1 March 1973.

### Air Wing Assignments

<i>Air Wing</i>	<i>Tail Code</i>	<i>Assignment Date</i>
RCVW-12	NJ	01 Sep 1967
COMFAIRWHIDBEY	NJ*	01 Jul 1970
COMMATVAQWINGPAC†	NJ	01 Mar 1973

### Unit Awards Received

<i>Unit Award</i>	<i>Inclusive Dates Covering Unit Award</i>	
MUC	15 Oct 1982	06 Jan 1984
	01 Feb 1987	01 Feb 1988
SLOC	01 Mar 1980	31 Mar 1981



*A squadron TC-4C Academe at Eglin AFB, Florida, in 1993.*

## VA-133

### Lineage

Established as Attack Squadron ONE HUNDRED THIRTY THREE (VA-133) on 21 August 1961.

Disestablished on 1 October 1962. The first squadron to be assigned the VA-133 designation.

### Squadron Insignia and Nickname

The squadron's insignia was approved by CNO on 13 February 1962. Colors for the blue knight

insignia were: a blue background; a white shield outlined in black; a yellow lightning bolt outlined in black; a blue chess knight with white markings and outlined in black; and the scroll had a white background, outlined in black and blue lettering.



The short lived "Blue Knight" insignia.

Nickname: Blue Knights, 1962.

### Chronology of Significant Events

**Aug 1961:** The squadron was established as part of a new Air Group to increase the strength of the fleet as a result of the Berlin Crisis of 1961–1962.

**8–19 Feb 1962:** A squadron detachment was aboard *Constellation* (CVA 64) for carrier trials and in a stand-by status for possible assistance during Project Mercury, the launching of Lieutenant Colonel John H. Glenn, USMC, in Mercury spacecraft Friendship 7.

**Mar–May 1962:** The squadron participated in *Constellation's* shakedown cruise in the Caribbean.

### Home Port Assignments

Location	Assignment Date
NAS Cecil Field	21 Aug 1961

### Commanding Officers

	Date Assumed Command
CDR M. A. Feher	21 Aug 1961

### Aircraft Assignment

Type of Aircraft	Date Type First Received
A4D-2	12 Sep 1961

### Air Wing Assignments

Air Wing	Tail Code	Assignment Date
CVG-13	AE	21 Aug 1961

## SECOND VA-134

### Lineage

Established as Attack Squadron ONE HUNDRED THIRTY FOUR (VA-134) on 21 August 1961.

Disestablished on 1 October 1962. The second squadron to be assigned the VA-134 designation.

### Squadron Insignia and Nickname

The squadron's insignia was approved by CNO on 15 February 1962. Colors for the scorpion insignia were: a burnt orange background and scroll, outlined in black; a white star with black highlights; the globe was outlined in black with a blue ocean and orange land mass, outlined in black; the scorpion was black with white highlights; the lettering was orange outlined in black.



*The scorpion insignia for VA-134.*

Nickname: Scorpions, 1962.

### Chronology of Significant Events

**Aug 1961:** The squadron was established as part of a new Air Group to increase the strength of the fleet during the Berlin Crisis of 1961–1962.

**Feb 1962:** The squadron was aboard *Constellation* (CVA 64) for carrier trials and in a stand-by status for possible assistance during Project Mercury, the launching of Lieutenant Colonel John H. Glenn, USMC, in Mercury spacecraft Friendship 7.

**Mar–May 1962:** The squadron participated in *Constellation's* shakedown cruise in the Caribbean.

### Home Port Assignments

<i>Location</i>	<i>Assignment Date</i>
NAS Cecil Field	21 Aug 1961

### Commanding Officers

	<i>Date Assumed Command</i>
CDR Kenneth B. Austin	21 Aug 1961

### Aircraft Assignment

<i>Type of Aircraft</i>	<i>Date Type First Received</i>
A4D-2	Sep 1961

### Air Wing Assignments

<i>Air Wing</i>	<i>Tail Code</i>	<i>Assignment Date</i>
CVG-13	AE	21 Aug 1961



*A squadron A4D-2 Skyhawk is prepared for launch from Constellation (CVA 64) in February 1962. This was the first aircraft launched from Constellation after her commissioning in October 1961.*

## VA-135

### Lineage

Established as Torpedo Squadron EIGHTY ONE (VT-81) on 1 March 1944.

Redesignated Attack Squadron FOURTEEN A (VA-14A) on 15 November 1946.

Redesignated Attack Squadron ONE HUNDRED THIRTY FIVE (VA-135) on 2 August 1948.

Disestablished on 30 November 1949. The first squadron to be assigned the VA-135 designation.

### Squadron Insignia and Nickname

There is no record of official approval for the squadron insignia. Colors for the bird insignia, which is believed to have been used by VA-14A, were: a white background with a green border; the bird's body and wings were black with white markings, red head and neck, orange beak and black eyes with red streaks; the machine gun in the beak was black and white, the legs were brown and the tailhook had black and white strips with a gray hook; the torpedo had a yellow warhead streaked with orange, the body was pale blue, the detonator was green and the propeller was yellow; the bomb was black and the rocket was gray with blue shading and a red flame.



*This insignia was used by VA-14A.*

Nickname: Uninvited, time frame unknown.

### Chronology of Significant Events

14 Nov 1944: The squadron's first combat strike was conducted against Manila Harbor.

9–20 Jan 1945: The squadron was part of a task force that entered the South China Sea and conducted combat operations against Cam Rahn Bay; Hong Kong and Takao Harbor, Formosa.

16 Feb 1945: The squadron struck the home islands of Japan, flying a seven-plane attack against Hamamatuo Airfield on Honshu.

21 Feb 1945: The squadron participated in its first ground support mission, flying sorties over Iwo Jima.

1 Mar 1945: The squadron flew its last combat strike of the war. During the four months of combat operations from *Wasp* (CV 18) it did not lose any personnel

due to enemy action (two personnel were lost due to operational accidents).

15–29 Jun 1946: The squadron embarked in *Princeton* (CV 37) and transited from Norfolk to San Diego via the Panama Canal.

### Home Port Assignments

<i>Location</i>	<i>Assignment Date</i>
NAS Quonset Point	01 Mar 1944
NAAF Martha's Vineyard	01 Mar 1944*
NAAF Boca Chica	20 Apr 1944*
NAAF Otis Field, Camp Edwards	10 May 1944*
NAS San Diego	10 Aug 1944*
NAS Puunene	01 Sep 1944*
NAS Pasco	13 May 1945*
NAAF Sanford, Maine	31 Jul 1945*
NAS Quonset Point	15 Sep 1945
NAS San Diego	Jun 1946
NAS Jacksonville	01 Apr 1949

\* Temporary shore assignment while the squadron conducted training in preparation for combat deployment.

### Commanding Officers

	<i>Date Assumed Command</i>
LT George D. M. Cunha	01 Mar 1944
LT John A. McGlinn, Jr.	13 May 1945
LT Harold E. Brown, Jr. (acting)	Jul 1945
LT Humphrey L. Tallman	20 Aug 1945
LCDR Albert K. Earnest	Apr 1947
LCDR Robert P. Chase	Jun 1948
LCDR LeVern C. T. Niehaus	21 Jun 1949

### Aircraft Assignment

<i>Type of Aircraft</i>	<i>Date Type First Received</i>
TBM-1C	Mar 1944
TBM-1	Mar 1944
TBF-1	Mar 1944
TBF-1C	Nov 1944
TBM-1D	Nov 1944
TBM-3	May 1945
TBM-3E	May 1945
TBM-3Q	1946
AD-4	Sep 1949

**Major Overseas Deployments**

<i>Date of Departure</i>	<i>Date of Return</i>	<i>Air Wing</i>	<i>Carrier</i>	<i>Type of Aircraft</i>	<i>Area of Operation</i>
10 Nov 1944	13 Mar 1945	CVG-81	CV 18	TBM-1C/D	Pacific
03 Jul 1946	15 Apr 1947	CVG-81	CV 37	TBM-3E/Q	WestPac
01 Oct 1948	16 Dec 1948	CVG-13	CV 37	TBM-3E/Q	WestPac

**Air Wing Assignments**

<i>Air Wing</i>	<i>Tail Code</i>	<i>Assignment Date</i>
CVG-81/CVAG-13/ CVG-13*	P†	01 Mar 1944

\* CVG-81 was redesignated CVAG-13 on 15 November 1946. CVAG-13 was redesignated CVG-13 on 1 September 1948. CVG-13 was disestablished on 30 November 1949.

† The tail code P was assigned to the carrier *Princeton* (CV 37) in November 1946 and then reassigned to CVAG-13 in December 1946.

**Unit Awards Received**

<i>Unit Award</i>	<i>Inclusive Dates Covering Unit Award</i>	
NUC	14 Nov 1944	19 Nov 1944
	14 Dec 1944	16 Dec 1944
	03 Jan 1945	22 Jan 1945
	16 Feb 1945	01 Mar 1945
Campaign Medal (Asiatic-Pacific)	14 Nov 1944	19 Nov 1944
	14 Dec 1944	16 Dec 1944
	03 Jan 1945	22 Jan 1945
	16 Feb 1945	01 Mar 1945



*A squadron TBM-3E in flight, March 1946 (Courtesy Robert Lawson Collection).*

## SECOND VA-135

### Lineage

Established as Attack Squadron ONE HUNDRED THIRTY FIVE (VA-135) on 21 August 1961.

Disestablished on 1 October 1962. The second squadron to be assigned the VA-135 designation.

### Squadron Insignia and Nickname

The squadron's insignia was approved by CNO on 15 February 1962. This insignia was similar to the



The Second VA-135 adopted the same insignia used by the first VA-135.

insignia that had been used by the first VA-135. Colors for the insignia were: upper background light blue, lower background dark blue; insignia outlined in green with a green scroll and white lettering; silver bird with white highlights and black outlines; the head and neck were red with a white star burst at the neck outlined in black; olive green beak and

legs outlined in black; white eye with a black pupil; white tailhook with black stripes; silver rocket and tor-

pedo with black markings and outlines; yellow bomb with black markings and outlines.

Nickname: Thunderbirds, 1962.

### Chronology of Significant Events

**Aug 1961:** The squadron was established as part of a new Air Group to increase the strength of the fleet during the Berlin Crisis of 1961–1962.

**Mar–May 1962:** The squadron participated in *Constellation's* shakedown cruise in the Caribbean.

### Home Port Assignments

Location	Assignment Date
NAS Jacksonville	21 Aug 1961
NAS Cecil Field	07 Aug 1962

### Commanding Officers

	Date Assumed Command
CDR Barclay W. Smith	21 Aug 1961

### Aircraft Assignment

Type of Aircraft	Date Type First Received
AD-6	21 Aug 1961

### Air Wing Assignments

Air Wing	Tail Code	Assignment Date
CVG-13	AE	21 Aug 1961



A squadron AD-6 Skyraider, August 1961. Commander G. C. Watkins, left, congratulates squadron CO Commander B. W. Smith on having the first plane in CVG-13 to fly operationally following the air group's establishment in 1961.

## VA-144

### Lineage

Established as Attack Squadron ONE HUNDRED SIXTEEN (VA-116) on 1 December 1955.

Redesignated Attack Squadron ONE HUNDRED FORTY FOUR (VA-144) on 23 February 1959.

Disestablished on 29 January 1971. The first squadron to be assigned the VA-144 designation.



*The insignia used by VA-116.*

outlined in white with a white scroll and black lettering; red lightning bolt; yellow electron rings and white stars. This insignia was retained by the squadron following its redesignation.

**Nickname:**  
Roadrunners,  
1960s–1971.

### Squadron Insignia and Nickname

The squadron's insignia was approved by CNO on 23 February 1956. Colors for the lightning bolt and electron ring insignia were: a black background



*When the squadron was redesignated VA-144, it continued to use the old insignia and changed only the lower banner designation.*

*A squadron F7U-3M with squadron personnel in formation during the establishment ceremony for VA-116 at NAS Miramar, California, in December 1955.*



### Chronology of Significant Events

**Sep 1957:** The squadron, embarked in *Hancock* (CVA 19), was on station off the coast of Taiwan due to a build-up of Chinese Communist forces on the mainland opposite Taiwan.

**26 May–18 Aug 1958:** The squadron was embarked in *Ranger* (CVA 61) during its transit from the east coast, via South America, to its new home port at Alameda.

**Jul 1959:** The squadron, embarked in *Ranger* (CVA 61), maintained station off the coast of Taiwan due to increased tension between Taiwan and Communist China.

**Jun–Nov 1964:** The squadron participated in Yankee Team Operations. These operations involved support for photo reconnaissance missions over Laos. During these operations, the squadron was the first operational unit to fly with and drop the Snakeeye weapon.

**4 Aug 1964:** The squadron flew night sorties in support of the American destroyers, *Turner Joy* (DD 951) and *Maddox* (DD 731), following their harassment by North Vietnamese Motor Torpedo Boats in the Gulf of Tonkin.

**5 Aug 1964:** VA-144 participated in Operation Pierce Arrow, air strikes against North Vietnamese torpedo boats, their bases and supporting facilities in retaliation for the attacks on the American destroyers the previous day. Strikes were flown against the North Vietnamese home port of Hon Gay and the naval craft located there. During this engagement Lieutenant (jg) Everett Alvarez's A-4C was hit by antiaircraft fire and he was forced to eject. A rescue attempt failed and he was captured. He became the first American naval prisoner-of-war during the Vietnam Conflict and was held by the North Vietnamese until 1973.

**20 Dec 1967:** Commanders J. R. Powell, Jr. and R. C. Bos were awarded the Silver Star for planning and leading a successful strike against the heavily defended Haiphong Thermal Power Plant (west).

**24 Apr 1967:** VA-144's aircraft participated in a strike against the Kep Airfield, the first time the airfield was hit during the air war over North Vietnam.



**Home Port Assignments**

<i>Location</i>	<i>Assignment Date</i>
NAS Miramar	01 Dec 1955
NAS Lemoore	May 1962



*A squadron F7U-3M Cutlass prepares to launch from Hancock (CVA 19) during their 1957 cruise to WestPac.*

**Commanding Officers—Continued**

	<i>Date Assumed Command</i>
CDR Robert P. Nottingham	02 Jan 1965
CDR David B. Miller	04 Nov 1965
CDR J. Richard Powell, Jr.	14 Sep 1966
CDR Gary H. Palmer	28 Jul 1967
CDR William H. Robinson, Jr.	26 Jul 1968
CDR Donald Hull-Ryde	17 Jul 1969
CDR Galen B. Allen	01 Jul 1970



*Two squadron FJ-4B Furys on the deck of Ranger (CVA 61) during their 1959 deployment to WestPac.*

**Commanding Officers**

	<i>Date Assumed Command</i>
CDR J. L. Callis	01 Dec 1955
CDR Ralph H. Beatle	10 Oct 1957
CDR James Ritchie	29 Aug 1958
CDR Carl B. Tanner, Jr.	12 Aug 1959
CDR Rowland G. Freeman III	10 Dec 1960
CDR Jerome S. Roth	12 Oct 1961
CDR Harry S. Sellers	02 Jan 1963
CDR Donald B. Bolstad	06 Dec 1963

**Aircraft Assignment**

<i>Type of Aircraft</i>	<i>Date Type First Received</i>
F7U-3M	Dec 1955
FJ-4B	15 Oct 1957
A-4C	04 Jun 1962
A-4E	Jul 1967
A-4F	12 Nov 1969

**Major Overseas Deployments**

<i>Date of Departure</i>	<i>Date of Return</i>	<i>Air Wing</i>	<i>Carrier</i>	<i>Type of Aircraft</i>	<i>Area of Operation</i>
06 Apr 1957	18 Sep 1957	ATG-2	CVA 19	F7U-3M	WestPac
03 Jan 1959	7 Jul 1959	CVG-14	CVA 61	FJ-4B	WestPac
14 May 1960	15 Dec 1960	CVG-14	CVA 34	FJ-4B	WestPac
09 Nov 1961	12 May 1962	CVG-14	CVA 16	FJ-4B	WestPac
21 Feb 1963	10 Sep 1963	CVG-14	CVA 64	A-4C	WestPac
05 May 1964	01 Feb 1965	CVW-14	CVA 64	A-4C	WestPac/Vietnam
28 Sep 1965	13 May 1966	CVW-5	CVA 14	A-4C	WestPac/Vietnam
05 Nov 1966	19 Jun 1967	CVW-11	CVA 63	A-4C	WestPac/Vietnam
18 Nov 1967	28 Jun 1968	CVW-11	CVA 63	A-4E	WestPac/Vietnam
18 Mar 1969	29 Oct 1969	CVW-5	CVA 31	A-4E	WestPac/Vietnam
02 Apr 1970	12 Nov 1970	CVW-5	CVA 31	A-4F	WestPac/Vietnam

**Air Wing Assignments**

<i>Air Wing</i>	<i>Tail Code</i>	<i>Assignment Date</i>
ATG-2	W/NB*	01 Dec 1955
CVG-14/CVW-14†	NK	01 Apr 1958
CVW-5	NF	01 Jun 1965
CVW-11	NH	15 Sep 1966
CVW-5	NF	01 Nov 1968

\* The tail code W was assigned to ATG-2 on 24 July 1956. It was changed to NB in 1957. The effective date for this change was most likely the beginning of FY 58 (1 July 1957).

† CVG-14 was redesignated CVW-14 when Carrier Air Group (CVG) designations were redesignated Carrier Air Wings (CVW) on 20 December 1963.

**Unit Awards Received—Continued**

<i>Unit Award</i>	<i>Inclusive Dates Covering Unit Award</i>	
VNSM	03 Sep 1969	
	13 Sep 1969	14 Sep 1969
	04 Nov 1965	22 Apr 1966
	03 Dec 1966	03 Jan 1967
	02 Mar 1967	28 Mar 1967
	12 Apr 1967	28 Apr 1967
	08 May 1967	23 May 1967
	04 Mar 1968	27 Mar 1968
	12 Apr 1968	01 May 1968
	13 May 1968	01 Jun 1968
	27 Jan 1969	01 Mar 1969
	12 Mar 1969	05 Apr 1969
	17 Apr 1969	18 May 1969
	04 Jun 1969	26 Jul 1969
	31 Jul 1969	01 Sep 1969
	23 Sep 1969	09 Oct 1969
	02 May 1970	26 May 1970
01 Jun 1970	14 Jun 1970	
10 Jul 1970	29 Jul 1970	
17 Aug 1970	03 Sep 1970	
11 Sep 1970	12 Sep 1970	
26 Sep 1970	21 Oct 1970	

**Unit Awards Received**

<i>Unit Award</i>	<i>Inclusive Dates Covering Unit Award</i>	
NAVE	01 Jul 1960	30 Jun 1961
PUC	23 Dec 1967	01 Jun 1968
MUC	18 Apr 1969	08 Oct 1969
	02 May 1970	20 Oct 1970
NUC	02 Aug 1964	05 Aug 1964
AFEM	29 Jun 1969	
	07 Jul 1969	13 Jul 1969
	24 Jul 1969	



*A squadron A-4F Skyhawk comes in for a landing on Bon Homme Richard (CVA 31) during deployment to Vietnam, circa 1969 or 1970.*

## VA-145

### Lineage

Established as Reserve Attack Squadron SEVEN HUNDRED TWO (VA-702) on 1 December 1949.

Reserve Attack Squadron SEVEN HUNDRED TWO (VA-702) called to active duty on 20 July 1950.

Redesignated Attack Squadron ONE HUNDRED FORTY FIVE (VA-145) on 4 February 1953.

Disestablished on 1 October 1993. The first squadron to be assigned the VA-145 designation.



The first insignia used by the squadron.

### Squadron Insignia and Nickname

The squadron's insignia was approved by CNO on 8 March 1951. There is no record of the color scheme for the insignia. The "Rustlers" insignia denotes the squadron's Texas origins and attack mission.

Following the redesignation of the squadron, a new insignia was approved by CNO on 7 April 1954. Colors for the sword and lion insignia are: a background of black, yellow and blue with a red border; the scroll is outlined in red with a yellow background and black lettering; the sword is silver and blue with a blue hilt, a yellow and black handle outlined in black; the lightning bolts are yellow; the lion is black with white markings and a red tongue and claws.



The squadron's second insignia was a more stylized design used by the squadron for almost 40 years.

Nickname: Rustlers, 1951–1954.

Swordsmen, 1954–1993.

### Chronology of Significant Events

**27 Mar 1951:** The squadron conducted its first combat sortie, flying close air support missions in Korea.

**Apr 1951:** The squadron, embarked in *Boxer* (CV 9), operated in the Formosa Straits.

**20 Sep 1951:** VA-702 flew its last close air support sortie in Korea and thereafter, concentrated its strikes on enemy facilities and targets of opportunity as part of the interdiction program. This policy, the result of

fairly stable front lines, was effective 21 September and applied to all units of the Fast Carrier Task Force. Close air support missions were now flown only by the Marine Corps and Air Force. This policy was modified later in the war and Fast Carrier Task Force squadrons again flew close air support missions.

**16 Oct 1952:** Commander B. T. Simonds, the squadron's commanding officer, was lost when his plane crashed into the water immediately following its launch from *Kearsarge* (CVA 33).

**Jun-Aug 1958:** The squadron was embarked in *Ranger* (CVA 61) for her transit from Norfolk, via Cape Horn, to her new home port at Alameda.

**5-8 Jul 1959:** The squadron, embarked in *Ranger*, flew sorties from the carrier while it operated off Taiwan due to increasing tensions between the Chinese Nationalists and Chinese Communists.

**Jun 1964-Jan 1965:** The squadron participated in Yankee Team Operations, flying Rescue Combat Air Patrols in South Vietnam and Laos.

**5 Aug 1964:** VA-145 participated in Operation Pierce Arrow, air strikes against North Vietnam in retaliation for the attacks on the American destroyers *Turner Joy* (DD 951) and *Maddox* (DD 731) in the Gulf of Tonkin on 4 August. The squadron's Skyraiders, along with other aircraft from the air wing, struck torpedo boats and other targets at Hon Gay, North Vietnam. A second sortie of squadron aircraft, along with Skyhawks from VA-144, attacked five enemy naval vessels that were at sea, near the Lach Chao Estuary and Hon Me Island. The two vessels attacked by VA-145 were left dead in the water and smoking. During this attack Lieutenant (jg) Richard C. Sather was shot down. He was the first naval aviator lost in the Vietnam Conflict.

**31 Jan 1966:** The squadron's commanding officer, Commander H. F. Griffith, was awarded the Silver Star for his actions as a flight leader directing and coordinating simultaneous attacks, under extremely adverse weather conditions, against a heavily defended primary enemy line of communications and for his participation in the successful rescue of a downed naval aviator.

**1 Feb 1966:** During one of the squadron's combat missions over North Vietnam, Lieutenant (jg) Dieter Dengler was shot down. He was captured in Laos and imprisoned. On 30 June 1966 he escaped from a prisoner-of-war stockade, was rescued and returned to the squadron on 21 July. For his daring escape he was awarded the Navy Cross.

**Jun-Nov 1967:** During 120 days on Yankee Station, the squadron assisted in the recovery of 14 downed airmen, both Navy and Air Force.

**16 Apr 1969:** *Enterprise*, with VA-145 embarked, departed Yankee Station enroute to Korean waters in response to the downing of a VQ-1 EC-121 aircraft by the North Koreans on 15 April. The squadron operated in the Sea of Japan and the Yellow Sea until 11 May.

**Dec 1972:** The squadron participated in Linebacker

II Operations, heavy air strikes against targets primarily around Hanoi and Haiphong.

**15 Jan 1973:** The squadron led the first massive laser bombing attack against targets in North Vietnam. A coordinated strike was launched involving squadron A-6s, which used their Pave Knife Laser Designation System, and A-7s from VA-113 and VA-25. These strikes succeeded in destroying 14 bridges in North Vietnam.

**Jan-Feb 1973:** Following the cease-fire with North Vietnam on 27 January, the squadron concentrated its attention on strikes against lines-of-communication targets in Laos until an agreement was reached with that country.

**Feb-Mar 1973:** The squadron flew limited sorties in support of Operation Endsweep, minesweeping operations in North Vietnamese waters.

**Jul 1976:** Following the Israeli raid on Entebbe and the threatened military operations against Kenya by Uganda, the *Ranger* (CV 61), with VA-145 embarked, was ordered to transit from the South China Sea to the western Indian Ocean and operate off the coast of Kenya.

**Aug-Nov 1987:** The squadron provided support for Operation Earnest Will, the escorting of reflagged Kuwaiti oil tankers through the Persian Gulf.

**Oct 1987:** VA-145 and other assets from CVW-2 provided support for Operation Nimble Archer, retaliatory strikes by surface forces against an Iranian oil platform used as a base by Iranian small boats that were attacking oil tankers.

**Aug 1989:** During a routine mission, a squadron aircraft sighted a foundering Vietnamese refugee boat leading to the rescue of 39 refugees by HS-14 and *Ranger*.

**15 Jan 1991:** *Ranger* (CV 61), with VA-145 embarked, transited to station in the Persian Gulf.

**16 Jan-28 Feb 1991:** The squadron participated in Desert Storm, flying combat missions against targets in Iraq and Kuwait. VA-145 flew 621 combat sorties, striking land based and sea based targets. Squadron strikes resulted in the destruction of 33 tanks, 1 bridge, 48 artillery pieces, 41 Iraqi naval vessels, 20 ammunition storage bunkers, 3 chemical weapon storage facilities, and 7 command and control sites. All of this was accomplished by the squadron without the loss of a single person or damage to its aircraft.

**17 Sep-3 Dec 1992:** Squadron aircraft flew missions in support of Operation Southern Watch. This operation was in support of UN Resolution 688, which demanded that Iraqi government stop the repression of its Shi'ite population in southern Iraq and banned Iraqi planes from flying south of the 32nd parallel.

**7-18 Dec 1992:** Squadron aircraft flew missions in support of Operation Restore Hope, a UN authorized effort to relieve mass starvation amid factional fighting in Somalia.



*A squadron AD-2 Skyraider prepares for launch from Boxer (CV 21) during their 1951 combat deployment to Korea.*

### Home Port Assignments

<i>Location</i>	<i>Assignment Date</i>
NAS Dallas	01 Dec 1949
NAS San Diego	28 Jul 1950
NAS Miramar	Mar 1953
NAS Moffett Field	May 1962
NAS Alameda	Sep 1963
NAS Whidbey Island	28 Jan 1968

### Commanding Officers

	<i>Date Assumed Command</i>
LCDR S. C. Seagraves	01 Dec 1949
CDR Bruce T. Simonds	06 Dec 1951
LCDR Harry C. McClaugherty (acting)	16 Oct 1952
LCDR Harry C. McClaugherty	28 Oct 1952
CDR John A. Duncan	May 1953
LCDR Gale L. Bergey	Jul 1954
CDR W. P. Blackwell	Feb 1956
CDR Charles S. Brooks	Jul 1957
CDR W. H. Alexander II	15 Sep 1958
CDR Harvey S. Herrick	Aug 1959
CDR Warren H. Ireland	11 May 1960
CDR Harvey S. Herrick	17 Aug 1960
CDR E. B. Berger	28 Dec 1960
LCDR B. L. Blackwelder (acting)	12 Sep 1961
CDR R. A. Norin	12 Oct 1961
CDR B. L. Blackwelder	14 Aug 1962
CDR H. A. Hoy	31 Jul 1963
CDR Melvin D. Blixt	03 Aug 1964
CDR H. F. Griffith	06 Aug 1965
CDR D. E. Sparks	03 Aug 1966
CDR W. J. Schultz	20 Jul 1967

**Commanding Officers—Continued**

**Aircraft Assignment**

	<i>Date Assumed Command</i>	<i>Type of Aircraft</i>	<i>Date Type First Received</i>
CDR N. R. Gooding, Jr.	02 Feb 1968	TBM	1949
CDR J. S. Holland	27 Apr 1969	AD-2	Aug 1950
CDR W. A. Rubey	29 Apr 1970	AD-4Q	Sep 1950
CDR G. E. Matt	23 Apr 1971	AD-1	Dec 1951
CDR R. S. Owens	29 Feb 1972	AD-4L	Apr 1952
CDR F. J. Metz	01 Jun 1973	AD-3Q	Apr 1953
CDR R. W. McFerren	15 Jul 1974	AD-4B	Apr 1953
CDR R. A. Powell	07 Nov 1975	AD-4NA	Aug 1954
CDR V. J. Huth	18 Feb 1977	AD-5	Oct 1954
CDR J. Juan	20 Jun 1978	AD-6/A-1H*	Feb 1956
CDR D. D. Williams	28 Sep 1979	A-6A	04 Jun 1968
CDR F. D. Litvin	08 Dec 1980	A-6B	06 Aug 1968
CDR M. J. Reilly	12 Mar 1982	A-6C	11 May 1970
CDR C. G. Overton	29 Jul 1983	KA-6D	1972
CDR A. N. Langston III	07 Dec 1984	A-6E	22 Sep 1976
CDR K. G. Bixler	21 Feb 1986	A-6E TRAM†	30 Nov 1981
CDR S. A. Hazelrigg	02 Nov 1987		
CDR Russell T. Palsgrove	30 Nov 1988		
CDR H. Denby Starling II	1990		
CDR Richard J. Cassara	29 Jul 1991		
CDR David A. Rogers	27 Nov 1992		

\* The AD-6 designation was changed to A-1H in 1962.

† The A-6E TRAM version was capable of carrying and firing the Harpoon missile (an antiship missile).



*A squadron A-1H Skyraider at NAS Alameda, California, in 1967. Note the unofficial Tonkin Gulf Yacht Club insignia on the fuselage (Courtesy Duane Kasulka Collection).*

**Major Overseas Deployments**

<i>Date of Departure</i>	<i>Date of Return</i>	<i>Air Wing</i>	<i>Carrier</i>	<i>Type of Aircraft</i>	<i>Area of Operation</i>
02 Mar 1951	24 Oct 1951	CVG-101	CV 21	AD-2/4Q	Korea/WestPac
11 Aug 1952	17 Mar 1953	CVG-101	CVA 33	AD-4/4L	Korea/WestPac
03 Jun 1955	03 Feb 1956	CVG-14	CVA 21	AD-4/4B	WestPac
21 Jan 1957	25 Jul 1957	CVG-14	CVA 12	AD-6	WestPac
03 Jan 1959	27 Jul 1959	CVG-14	CVA 61	AD-6	WestPac
14 May 1960	15 Dec 1960	CVG-14	CVA 34	AD-6	WestPac
09 Nov 1961	12 May 1962	CVG-14	CVA 16	AD-6	WestPac
21 Feb 1963	10 Sep 1963	CVG-14	CVA 64	A-1H	WestPac
05 May 1964	01 Feb 1965	CVW-14	CVA 64	A-1H/J	WestPac/Vietnam
10 Dec 1965	25 Aug 1966	CVW-14	CVA 61	A-1H/J	WestPac/Vietnam
11 May 1967	30 Dec 1967	CVW-10	CVS 11	A-1H	Med/IO/West Pac/Vietnam
06 Jan 1969	02 Jul 1969	CVW-9	CVAN 65*	A-6A/B	WestPac/Vietnam
27 Oct 1970	17 Jun 1971	CVW-2	CVA 61	A-6A/C	WestPac/Vietnam
16 Nov 1972	23 Jun 1973	CVW-2	CVA 61	A-6A/B & KA-6D	WestPac/Vietnam
07 May 1974	18 Oct 1974	CVW-2	CVA 61	A-6A & KA-6D	WestPac
30 Jan 1976	07 Sep 1976	CVW-2	CV 61	A-6A & KA-6D	WestPac/IO
21 Feb 1979	22 Sep 1979	CVW-2	CV 61	A-6E & KA-6D	WestPac
10 Sep 1980	05 May 1981	CVW-2	CV 61	A-6E & KA-6D	WestPac/IO
07 Apr 1982	19 Oct 1982	CVW-2	CV 61	A-6E & KA-6D	WestPac/IO
13 Jan 1984	01 Aug 1984	CVW-2	CV 63	A-6E & KA-6D	WestPac/IO
18 Aug 1986	20 Oct 1986	CVW-2	CV 61	A-6E & KA-6D	NorPac/WestPac
02 Mar 1987	29 Apr 1987	CVW-2	CV 61	A-6E & KA-6D	NorPac
14 Jul 1987	29 Dec 1987	CVW-2	CV 61	A-6E	WestPac/IO
24 Feb 1989	24 Aug 1989	CVW-2	CV 61	A-6E	WestPac/IO
08 Dec 1990	08 Jun 1991	CVW-2	CV 61	A-6E	WestPac/IO/ Persian Gulf
01 Aug 1992	31 Jan 1993	CVW-2	CV 61	A-6E	WestPac/IO/ Persian Gulf

\* The squadron was temporarily shore based at NAS Barbers Point from January to March 1969 following a fire on *Enterprise* (CVAN 65) on 14 January 1969. The carrier was repaired at Pearl Harbor and was enroute to WestPac on 11 March with VA-145 embarked.

**Air Wing Assignments**

<i>Air Wing</i>	<i>Tail Code</i>	<i>Assignment Date</i>
CVG-101/CVG-14/ CVW-14*	A/NK†	01 Aug 1950
COMFAIRALAMEDA		Oct 1966
CVW-10	AK	1967
COMFAIRWHIDBEY/ VA-128‡		Jan 1968
CVW-9	NG	Sep 1968
COMFAIRWHIDBEY		02 Jul 1969
CVW-2	NE	01 Jun 1970

\* CVG-101 was redesignated CVG-14 on 4 February 1953. CVG-14 was redesignated CVW-14 when Carrier Air Groups (CVG) were redesignated Carrier Air Wings (CVW) on 20 December 1963.

† The tail code was changed from A to NK in 1957. The effective date for this change was most likely the beginning of FY 58 (1 July 1957).

‡ The squadron was assigned to VA-128 during its transition from the A-1 to the A-6.

**Unit Awards Received**

<i>Unit Award</i>	<i>Inclusive Dates Covering Unit Award</i>
KSM	26 Mar 1951 09 Apr 1951
	16 Apr 1951 08 Oct 1951
	08 Sep 1952 29 Oct 1952
	31 Oct 1952 05 Jan 1953
	19 Jan 1953 28 Feb 1953
NAVE	01 Jan 1973 30 Jun 1974
AFEM	09 Oct 1960 12 Oct 1960
	06 Jun 1964 13 Jul 1964
	04 Aug 1964 21 Sep 1964
	29 Oct 1964 23 Nov 1964
	20 Apr 1969 11 May 1969
HSM	20 Mar 1981
MUC	18 Nov 1970 10 Jun 1971
NEM	30 Oct 1980 12 Mar 1981
NUC	02 Aug 1964 05 Aug 1964
	10 Jan 1966 06 Aug 1966
	12 Jun 1967 08 Dec 1967

**Unit Awards Received—Continued**

<i>Unit Award</i>	<i>Inclusive Dates Covering Unit Award</i>	
	18 Jul 1988	24 Aug 1989
	17 Jan 1991	07 Feb 1991
SASM	13 Jan 1991	19 Apr 1991
KLM	17 Jan 1991	28 Feb 1991
VNSM	15 Jan 1966	12 Feb 1966
	23 Feb 1966	22 Mar 1966
	12 Apr 1966	09 May 1966
	30 May 1966	30 Jun 1966
	13 Jul 1966	06 Aug 1966
	21 Jun 1967	13 Jul 1967
	29 Jul 1967	27 Aug 1967
	14 Sep 1967	12 Oct 1967
	31 Oct 1967	24 Nov 1967
	30 Mar 1969	17 Apr 1969
	22 May 1969	23 May 1969
	29 May 1969	16 Jun 1969
	18 Nov 1970	19 Dec 1970
	27 Dec 1970	13 Jan 1971
	02 Feb 1971	17 Mar 1971
	31 Mar 1971	18 Apr 1971
	25 Apr 1971	18 May 1971

**Unit Awards Received—Continued**

<i>Unit Award</i>	<i>Inclusive Dates Covering Unit Award</i>	
	09 Dec 1972	03 Jan 1973
	14 Jan 1973	30 Jan 1973
	01 Feb 1973	06 Feb 1973
RVNGC	24 Jan 1966	
	26 Jan 1966	27 Jan 1966
	30 Jan 1966	
	04 Feb 1966	
	06 Feb 1966	
	24 Feb 1966	
	26 Feb 1966	28 Feb 1966
	04 Mar 1966	
	06 Mar 1966	12 Mar 1966
	20 Mar 1966	
	27 Apr 1966	28 Apr 1966
	21 Jun 1967	13 Jul 1967
	29 Jul 1967	27 Aug 1967
	14 Sep 1967	12 Oct 1967
	31 Oct 1967	24 Nov 1967
	31 Mar 1969	03 Apr 1969
	05 Apr 1969	
	31 May 1969	16 Jun 1969



*A couple of squadron A-6E Intruders fly over Ranger (CV 61) in 1992 during the squadron's last deployment prior to its 1993 disestablishment.*

## VA-152

### Lineage

Established as Reserve Fighter Squadron SEVEN HUNDRED THIRTEEN (VF-713) sometime in the late 1940s.

Called to active duty on 1 February 1951.

Redesignated Fighter Squadron ONE HUNDRED FIFTY TWO (VF-152) on 4 February 1953.

Redesignated Attack Squadron ONE HUNDRED FIFTY TWO (VA-152) on 1 August 1958.

Disestablished on 29 January 1971. The first squadron to be assigned the VA-152 designation.

### Squadron Insignia and Nickname

The squadron's first insignia was approved by CNO on 15 April 1952. Colors for the hooded falcon insignia were: the shield had a white and black background outlined in gold; brown falcon with white and light brown shadings; yellow feet and beak; the hood was crimson with a gold edge and a white plume; and the gauntlet was silver edged in blue with gray shadings.



*The hooded falcon was the squadron's first insignia.*

A new insignia was approved by the CNO on 11 March 1953. Colors for the vulture insignia were: background of light blue, yellow and dark blue, outlined in yellow; gray vulture with black and white markings and wings, outlined in yellow; red neck and feet; a yellow head with black markings and a white beak; black bomb with white highlights and outlined in yellow.

There is no record of approval for the ace of spades insignia. Colors for the flying ace of spades insignia were: a black background for the insignia and scroll, outlined in red; the ace of spades was white with black markings;



*The squadron's second insignia, a vulture carrying a bomb, was approved in 1953.*



*The squadron's third insignia was the flying ace of spades.*

the wings were gold with black markings; the arrow was gold with white streaks; and gold lettering on the scroll.

Nickname: Fighting Aces, 1953–1956.

The Friendly Squadron (Friendlies), 1957–1968.

Mavericks, 1968–1971.

### Chronology of Significant Events

**15 Oct 1951:** The squadron participated in its first combat operations.

**31 Dec 1951:** Squadron aircraft were used for Operation Pin Wheel. The aircraft were secured to the flight deck, with engines running, and the thrust provided by the aircraft was used to assist in the docking of *Antietam* (CV 36).

**Feb 1955:** Squadron aircraft flew night surveillance operations supporting the evacuation of Chinese Nationalists from the Tachen Islands.

**Mar 1958:** Due to revolts and unsettled conditions in Indonesia and the concern for the safety of Americans in the country, *Hornet* (CVA 12), with VF-152 embarked, departed Hong Kong to operate in the South China Sea.

**Sep–Oct 1958:** Due to the crisis between the Chinese Nationalists and Communists surrounding the Quemoy Islands, and the bombardment of these islands by the Chinese Communists, *Bennington* (CVA 20), with VF-152 embarked, operated in the area of Taiwan.

**Jan 1961:** Due to the crisis in Laos and the capture of strategic positions in the country by the Pathet Lao force, *Coral Sea* (CVA 43), with VA-152 embarked, was directed to operate in the South China Sea.

**11–12 Jul 1962:** The squadron participated in the first carrier flight operations in the Bering Sea since the end of World War II.

**Apr–Dec 1964:** Squadron personnel, while based at Bien Hoa Air Force Base, South Vietnam, trained South Vietnamese pilots to fly the A-1.

**6 and 7 Nov 1965:** Commander Gordon H. Smith was awarded the Silver Star for his participation as Flight Leader in directing and assisting in the first night rescue of a downed aviator in enemy territory on 6 November. This was followed by an attempt to rescue another aviator the following day in the same area.

**7 Nov 1965:** Lieutenant Gordon C. Wileen was awarded the Silver Star for his participation in an attempted air rescue of a downed aviator deep in enemy territory.



13 Nov 1965: Commander Albert E. Knutson was awarded the Silver Star for his attempt to locate and rescue a downed pilot in enemy territory. During the rescue attempt his aircraft sustained 26 hits.

26 Oct 1966: While on Yankee Station and preparing

to launch her first strike of the day, *Oriskany* (CVA 34) suffered a disastrous fire on the starboard side of the ship's forward hangar bay. The squadron lost two personnel in the fire and the damage to the carrier was so extensive that it returned to the States for repairs.



*A squadron F4U-4 Corsair launches from Princeton (CVA 37) during their 1953 combat deployment to Korea.*

**Home Port Assignments**

<i>Location</i>	<i>Assignment Date</i>
NAS Denver	*
NAS Alameda	11 Apr 1951
NAS Moffett Field	05 Jun 1952
NAS Alameda	Nov 1963

\* Assigned to NAS Denver prior to 1951, exact date unknown.



*A formation of squadron F2H-3 Banshees stationed aboard Yorktown (CVA 10), November 1954.*

**Commanding Officers**

	<i>Date Assumed Command</i>
LCDR Robert L. Doering	*
LCDR B. M. Richards	02 May 1952
LT W. M. Doss (acting)	04 Jul 1952
LCDR Robert Stanek	05 Aug 1952
CDR Frank G. Edwards	Sep 1953
LCDR F. X. Bushner (acting)	†
LCDR Robert G. Nester	Apr 1955
CDR Robert M. Soule	27 Sep 1956
CDR Royce A. Singleton	23 Jul 1958
LCDR V. E. Sanderson	16 Feb 1959
LCDR R. M. Sullivan (acting)	08 Feb 1960
CDR John A. Davenport	04 Mar 1960
CDR John R. Bicknell	21 Jun 1961
CDR Isaac N. Pell, Jr.	17 Apr 1962
CDR R. B. Bergner	01 Apr 1963
CDR H. F. Gernert	03 Mar 1964
CRR Albert E. Knutson	19 Mar 1965
CDR Gordon H. Smith	25 Feb 1966
CDR Donald M. Willson	16 Mar 1967
CDR Philip E. Johnson	14 Feb 1968
CDR Elmer E. Sheeley, Jr.	17 Jan 1969
CDR Gerard M. Sturm	28 Jan 1970

\* LCDR Doering was commanding officer of the reserve squadron prior to its activation.

† LCDR Bushner became acting commanding officer in late 1954 or early 1955.

**Aircraft Assignment**

<i>Type of Aircraft</i>	<i>Date Type First Received</i>
F4U-4	16 Apr 1951
FG-1D	12 Jun 1952
F2H-3	Oct 1953
AD-6/A-1H*	05 Feb 1959
A-1J	Dec 1962
A-4B	Feb 1968
A-4C	Feb 1968
A-4E	May 1969

\* The AD-6 designation was changed to A-1H in 1962.



A loaded squadron AD-6 Skyraider on the deck of Coral Sea (CVA 43), 1960.

**Major Overseas Deployments**

<i>Date of Departure</i>	<i>Date of Return</i>	<i>Air Wing</i>	<i>Carrier</i>	<i>Type of Aircraft</i>	<i>Area of Operation</i>
08 Sep 1951	02 May 1952	CVG-15	CV 36	F4U-4	Korea
24 Jan 1953	21 Sep 1953	CVG-15	CVA 37	F4U-4	Korea/WestPac
01 Jul 1954	28 Feb 1955	CVG-15	CVA 10	F2H-3	WestPac
23 Apr 1956	15 Oct 1956	CVG-15	CVA 18	F2H-3	WestPac
06 Jan 1958	30 Jun 1958	ATG-4	CVA 12	F2H-3	WestPac
21 Aug 1958	12 Jan 1959	ATG-4	CVA 20	F2H-3	WestPac
01 Aug 1959	18 Jan 1960	CVG-15	CVA 19	AD-6	WestPac
19 Sep 1960	27 May 1961	CVG-15	CVA 43	AD-6	WestPac
12 Dec 1961	17 Jul 1962	CVG-15	CVA 43	AD-6	WestPac
03 Apr 1963	25 Nov 1963	CVG-15	CVA 43	A-1H/J	WestPac
22 Apr 1964	01 Aug 1964	*	*	A-1H/J	South Vietnam
05 Apr 1965	16 Dec 1965	CVW-16	CVA 34	A-1H/J	WestPac/Vietnam
26 May 1966	16 Nov 1966	CVW-16	CVA 34	A-1H	WestPac/Vietnam
16 Jun 1967	31 Jan 1968	CVW-16	CVA 34	A-1H/J	WestPac/Vietnam
22 Jul 1968	29 Apr 1969	CVW-17	CVA 59	A-4B	Med
05 Mar 1970	17 Dec 1970	CVW-8	CVS 38	A-4E	SoLant/IO/West Pac/Vietnam

\* The squadron, along with 20 of its A-1s, was sent to Bien Hoa Air Force Base, South Vietnam, to train South Vietnamese pilots to fly the A-1. A detachment, VA-152 Det Zulu, was left at NAS Alameda. While operating in South Vietnam the squadron came under the control of Chief, Air Force Advisory Group, Saigon. On 1 August 1964 the squadron (VA-152) based at Bien Hoa was redesignated VA-152 Det Zulu and the detachment at NAS Alameda was designated VA-152. VA-152 Det Zulu continued to train South Vietnamese pilots until 1 December 1964.



A couple of squadron AD-6 Skyraiders in flight, circa 1960–1961.

**Air Wing Assignments**

Air Wing	Tail Code	Assignment Date
CVG-15	H	11 Apr 1951
ATG-4	ND	14 Oct 1957
CVG-15/CVW-15*	NL	Feb 1959
CVW-16	AH	01 Oct 1964
CVW-17	AA	Feb 1968
COMFAIRALAMEDA		Apr 1969
CVW-8	AJ	Dec 1969

\* CVG-15 was redesignated CVW-15 when Carrier Air Groups (CVG) were redesignated Carrier Air Wings (CVW) on 20 December 1963.

**Unit Awards Received**

Unit Award	Inclusive Dates Covering Unit Award	
KSM	04 Oct 1951	15 Apr 1952
	27 Feb 1953	16 May 1953
	29 May 1953	07 Sep 1953
NUC	13 Mar 1953	15 May 1953
	11 Jun 1953	27 Jul 1953

**Unit Awards Received—Continued**

Unit Award	Inclusive Dates Covering Unit Award	
AFEM	10 May 1965	06 Dec 1965
	12 Jun 1966	01 Nov 1966
	14 Jul 1967	12 Jan 1968
	24 Nov 1958	03 Dec 1958
	14 Sep 1959	17 Sep 1959
	25 Apr 1961	28 Apr 1961
	30 Apr 1961	01 May 1961
	04 May 1961	09 May 1961
	12 Jan 1962	19 Jan 1962
	24 Jan 1962	27 Jan 1962
	22 Apr 1964	31 Jul 1964
	07 May 1965	02 Jun 1965
	10 Jun 1965	03 Jul 1965
	17 Sep 1965	18 Sep 1965
AFEM (VA-152 Det Z)	31 Jul 1964	01 Sep 1964
MUC	11 Apr 1970	06 Nov 1970
VNSM	04 Jul 1965	18 Jul 1965
	09 Aug 1965	11 Sep 1965
	28 Oct 1965	27 Nov 1965
	06 Jul 1966	
	07 Aug 1966	08 Sep 1966
	24 Sep 1966	26 Oct 1966
	10 Apr 1970	02 May 1970
	12 May 1970	29 May 1970
	13 Jun 1970	04 Jul 1970
	28 Jul 1970	19 Aug 1970
RVNGC	30 Aug 1970	30 Sep 1970
	20 Oct 1970	07 Nov 1970
	02 Oct 1965	
	30 Oct 1965	
	01 Nov 1965	
	03 Nov 1965	
	11 Nov 1965	12 Nov 1965
	06 Jul 1966	07 Jul 1966

A squadron A-4E at NAS Alameda, California, circa 1970.



## VA-153

### Lineage

During a reorganization of the Naval Air Reserve, a Fighter Squadron at NAS New York (believed to have been VF-718) was redesignated Fighter Squadron EIGHT HUNDRED THIRTY ONE (VF-831) in September 1949.

Reserve Fighter Squadron EIGHT HUNDRED THIRTY ONE (VF-831) was called to active duty on 1 February 1951.

Redesignated Fighter Squadron ONE HUNDRED FIFTY THREE (VF-153) on 4 February 1953.

Redesignated Attack Squadron ONE HUNDRED FIFTY THREE (VA-153) on 15 December 1956.

Disestablished on 30 September 1977. The first squadron to be assigned the VA-153 designation.

### Squadron Insignia and Nickname



*The squadron's only insignia sported the mythical griffin.*

The squadron's insignia was approved by CNO on 17 May 1951. Colors for the griffin insignia were: light blue background outlined in orange; the griffin's body was black with white highlights, its beak and claws were orange and yellow, and the eagle head was white. Following the

squadron's two designation changes the basic insignia continued in use with minor modifications.

Nickname: Blue Tail Flies, 1953–1977.

### Chronology of Significant Events

**Feb 1955:** Squadron aircraft flew sorties in support of the evacuation of Chinese Nationalists from the Tachen Islands.

**23 Aug–9 Sep 1958:** The squadron flew sorties in the Taiwan Straits after the Chinese Communists bombarded Quemoy Island.

**Jan 1961:** *Coral Sea* (CVA 43), with VA-153 embarked, operated in the South China Sea after Pathet Lao forces captured strategic positions in Laos.

**2 Feb 1965:** The squadron began participating in operations in Laos. These operations involved Yankee Team, Barrel Roll and Steel Tiger missions.

**7 and 11 Feb 1965:** The squadron participated in Flaming Dart I and II, reprisal strikes against targets in North Vietnam following a Viet Cong attack on the American advisors compound at Pleiku and the American billet in Qui Nhon, South Vietnam.

**Mar 1965:** The squadron participated in Rolling Thunder operations, the bombing of military targets in North Vietnam.

**13 Aug 1965:** The squadron's commanding officer, Commander H. E. Thomas, was killed in action over North Vietnam.

**Mar 1968:** *Coral Sea* (CVA 43), with VA-153 embarked, operated on station off the coast of Korea following the capture of *Pueblo* (AGER 2) in January by North Korea.

**21 Nov 1970:** The squadron flew missions in support of an attempt to rescue American prisoners-of-war at the Son Tay prisoner compound, 20 miles west of Hanoi.

**11–22 Feb 1973:** Following the cease fire with North Vietnam the squadron flew combat missions in Laos until a cease fire was signed with that country on 22 February 1973.

**Feb 1973:** Commander D. R. Weichman, the squadron's executive officer, completed his 625th combat mission of the Vietnam Conflict. He maintains the record for the highest number of combat missions for a Navy fixed-wing pilot during this conflict.

**Nov 1973:** *Oriskany* (CVA 34), with VA-153 embarked, departed from operations in the South China Sea to relieve *Hancock* (CVA 19) on station in the Arabian Sea due to the unsettled conditions following the Yom Kippur War in the Middle East.

*A VF-831 F9F-2 Panther on the deck of Antietam (CV 36) in January 1952 during combat operations off the coast of Korea.*



### Home Port Assignments

<i>Location</i>	<i>Assignment Date</i>
NAS New York, Floyd Bennett Field	*
NAS Alameda	01 Apr 1951
NAS Moffett Field	05 May 1952
NAS Lemoore	21 Aug 1961

\* Assigned to NAS New York prior to the squadron's recall to active duty on 1 February 1951.

### Commanding Officers

	<i>Date Assumed Command</i>
LCDR A. J. Denman	*
LCDR G. E. Miller	05 May 1952
LCDR Loys M. Satterfield	Sep 1953
CDR W. L. Abbott	Mar 1955
CDR Alexander D. C. Byers	1956
LCDR Hildry L. Nelson	27 Feb 1957
CDR John F. Bauman	17 Oct 1958
CDR Vernon R. Fierce, Jr.	08 Feb 1960
CDR W. C. May	21 Jun 1961
CDR Zeb V. Knott	30 Jul 1962
CDR William C. Raposa	10 Jul 1963
CDR Peter Mongilardi, Jr.	26 May 1964
CDR Harry E. Thomas (acting commanding officer)	Apr 1965
CDR K. V. McArthur	13 Aug 1965
CDR D. E. Leue	15 Sep 1965
CDR D. E. Leue	25 Jul 1966
CDR T. E. Woolcock	1967
CDR R. J. Dapogny	08 May 1968
CDR Olaf M. Carlson, Jr.	23 May 1969
CDR Peter G. Frederick	20 Aug 1970
CDR William J. M. O'Connor	11 Jun 1971
CDR Paul D. Stephenson	01 Jun 1972
CDR Denis R. Weichman	27 Jul 1973
LCDR Keith S. Jones	20 Sep 1974
LCDR Robert F. Hofford	12 Sep 1975
CDR Lawrence H. Price	15 Dec 1976

\* LCDR Denman was commanding officer of the reserve squadron prior to its activation on 1 February 1951.



Squadron F9F-6 Cougars flying over Mount Fuji, Japan, in December 1954 while the squadron was deployed aboard Yorktown (CVA 10) (USN, Courtesy Duane Kasulka Collection).

### Aircraft Assignment

<i>Type of Aircraft</i>	<i>Date Type First Received</i>
F6F	*
F9F-2	06 Feb 1951
F9F-5	Aug 1952
F9F-6	Oct 1953
FJ-3	Mar 1955
F9F-8	Nov 1955
F9F-8B	Apr 1956
A4D-1	12 Feb 1957
A4D-2	27 Oct 1958
A4D-2N/A-4C†	20 Jun 1961
A-4E	Jan 1967
A-4F	Apr 1968
A-7A	14 Sep 1969
A-7B	May 1973

\* While in a reserve status from September 1949 to January 1951, the squadron was most likely utilizing F6F pool aircraft assigned to NAS New York.

† The A4D-2N designation was changed to A-4C in 1962.

### Major Overseas Deployments

<i>Date of Departure</i>	<i>Date of Return</i>	<i>Air Wing</i>	<i>Carrier</i>	<i>Type of Aircraft</i>	<i>Area of Operation</i>
08 Sep 1951	02 May 1952	CVG-15	CV 36	F9F-2	Korea
24 Jan 1953	21 Sep 1953	CVG-15	CVA 37	F9F-5	Korea/WestPac
01 Jul 1954	28 Feb 1955	CVG-15	CVA 10	F9F-6	WestPac
23 Apr 1956	15 Oct 1956	CVG-15	CVA 18	F9F-8/8B	WestPac
15 Feb 1958	02 Oct 1958	CVG-15	CVA 19	A4D-1	WestPac
01 Aug 1959	18 Jan 1960	CVG-15	CVA 19	A4D-2	WestPac
19 Sep 1960	27 May 1961	CVG-15	CVA 43	A4D-2	WestPac
12 Dec 1961	17 Jul 1962	CVG-15	CVA 43	A4D-2N	WestPac
03 Apr 1963	25 Nov 1963	CVG-15	CVA 43	A-4C	WestPac
07 Dec 1964	01 Nov 1965	CVW-15	CVA 43	A-4C	WestPac/Vietnam

**Major Overseas Deployments—Continued**

<i>Date of Departure</i>	<i>Date of Return</i>	<i>Air Wing</i>	<i>Carrier</i>	<i>Type of Aircraft</i>	<i>Area of Operation</i>
12 May 1966	03 Dec 1966	CVW-15	CVA 64	A-4C	WestPac/Vietnam
26 Jul 1967	06 Apr 1968	CVW-15	CVA 43	A-4E	WestPac/Vietnam
07 Sep 1968	18 Apr 1969	CVW-15	CVA 43	A-4F	WestPac/Vietnam
14 May 1970	10 Dec 1970	CVW-19	CVA 34	A-7A	WestPac/Vietnam
14 May 1971	18 Dec 1971	CVW-19	CVA 34	A-7A	WestPac/Vietnam
05 Jun 1972	30 Mar 1973	CVW-19	CVA 34	A-7A	WestPac/Vietnam
18 Oct 1973	05 Jun 1974	CVW-19	CVA 34	A-7B	WestPac/IO
16 Sep 1975	03 Mar 1976	CVW-19	CV 34	A-7B	WestPac
04 Oct 1976	21 Apr 1977	CVW-19	CV 42	A-7B	Med

**Air Wing Assignments**

<i>Air Wing</i>	<i>Tail Code</i>	<i>Assignment Date</i>
CVG-15/CVW-15†	H/NL*	Apr 1951
COMFAIRLEMOORE		1969
CVW-19	NM	22 Nov 1969

\* The tail code was changed from H to NL in 1957. The effective date for this change was most likely the beginning of FY 58 (1 July 1957).

† CVG-15 was redesignated CVW-15 when Carrier Air Groups (CVG) were redesignated Carrier Air Wings (CVW) on 20 December 1963.

**Unit Awards Received**

<i>Unit Award</i>	<i>Inclusive Dates Covering Unit Award</i>	
KSM	04 Oct 1951	15 Apr 1952
	27 Feb 1953	16 May 1953
	29 May 1953	07 Sep 1953
	01 Jan 1973	30 Jun 1974
NAVE	01 Jul 1974	01 Apr 1976
	02 Apr 1976	30 Jun 1977
	26 Aug 1958	07 Sep 1958
AFEM	14 Sep 1959	17 Sep 1959



*A squadron A-4F Skyhawk prepares to launch from Coral Sea (CVA 43), 1969.*

**Unit Awards Received—Continued**

<i>Unit Award</i>	<i>Inclusive Dates Covering Unit Award</i>	
	25 Apr 1961	28 Apr 1961
	30 Apr 1961	01 May 1961
	04 May 1961	09 May 1961
	12 Jan 1962	19 Jan 1962
	24 Jan 1962	27 Jan 1962
	02 Feb 1965	05 Mar 1965
	16 Mar 1965	17 Apr 1965
	02 May 1965	28 May 1965
	23 Jun 1965	03 Jul 1965
	23 Jan 1968	22 Mar 1968
NUC	13 Mar 1953	15 May 1953
	11 Jun 1953	27 Jul 1953
	07 Feb 1965	18 Oct 1965
	29 May 1966	24 Nov 1966
	13 Aug 1967	19 Feb 1968
MUC	10 Oct 1968	31 Mar 1969
	01 Jun 1970	09 Dec 1970
	28 Jun 1972	06 Mar 1973
RVNGC	12 Oct 1965	
	21 Jun 1966	22 Jun 1966
	23 Nov 1967	
	02 Dec 1967	
	04 Dec 1967	
	20 Dec 1967	22 Dec 1967
	20 Jan 1968	
	23 Jan 1968	27 Jan 1968
	29 Jan 1968	19 Feb 1968
	15 Oct 1968	
	17 Oct 1968	18 Oct 1968
	21 Oct 1968	
	25 Oct 1968	27 Oct 1968
	14 Nov 1968	16 Nov 1968
	23 Nov 1968	
	25 Nov 1968	
	01 Dec 1968	02 Dec 1968
	04 Dec 1968	05 Dec 1968
	30 Dec 1968	
	01 Jan 1969	03 Jan 1969
	05 Jan 1969	
	07 Jan 1969	10 Jan 1969

**Unit Awards Received—Continued**

<i>Unit Award</i>	<i>Inclusive Dates Covering Unit Award</i>	
	14 Jan 1969	19 Jan 1969
	22 Jan 1969	
	24 Jan 1969	
	26 Jan 1969	
	09 Feb 1969	20 Feb 1969
	22 Feb 1969	03 Mar 1969
	19 Mar 1969	31 Mar 1969
VNSM	04 Jul 1965	24 Jul 1965
	11 Aug 1965	11 Sep 1965
	21 Sep 1965	15 Oct 1965
	14 Jun 1966	13 Jul 1966
	27 Jul 1966	31 Aug 1966
	08 Sep 1966	01 Oct 1966
	19 Oct 1966	09 Nov 1966
	26 Aug 1967	01 Oct 1967
	12 Oct 1967	28 Oct 1967
	04 Nov 1967	05 Nov 1967
	11 Nov 1967	08 Dec 1967
	16 Dec 1967	07 Jan 1968
	15 Jan 1968	21 Feb 1968
	29 Dec 1968	30 Jan 1969
	08 Feb 1969	03 Mar 1969
	19 Mar 1969	30 Mar 1969
	13 Jun 1970	29 Jun 1970
	12 Jul 1970	22 Jul 1970
	02 Aug 1970	26 Aug 1970
	17 Sep 1970	13 Oct 1970
	06 Nov 1970	23 Nov 1970
	15 Jun 1971	10 Jul 1971
	24 Jul 1971	07 Aug 1971
	03 Sep 1971	27 Sep 1971
	29 Oct 1971	21 Nov 1971
	26 Jun 1972	23 Jul 1972
	16 Aug 1972	01 Sep 1972
	11 Sep 1972	28 Sep 1972
	08 Oct 1972	31 Oct 1972
	24 Nov 1972	18 Dec 1972
	27 Dec 1972	31 Jan 1973
	10 Feb 1973	06 Mar 1973



*A squadron A-7B Corsair II at NAS Glenview, Illinois, August 1973 (Courtesy Fred Roos Collection).*

## VA-154

### *Lineage*

Established as Bombing Squadron ONE HUNDRED FIFTY THREE (VB-153) on 26 March 1945.

Redesignated Attack Squadron FIFTEEN A (VA-15A) on 15 November 1946.

Redesignated Attack Squadron ONE HUNDRED FIFTY FOUR (VA-154) on 15 July 1948.

Disestablished on 1 December 1949. The first squadron to be designated VA-154.

### *Squadron Insignia and Nickname*

The first squadron insignia, a Walt Disney design, was approved by CNO on 10 August 1945. Colors for



*The squadron's first insignia was a Walt Disney design.*

the flying cannon were: a maroon background outlined in yellow; black cannon with blue and white highlights; silver wings and neck with white highlights and black markings; the bomb head was black with blue highlights and a yellow and orange eye and white teeth; the rocket legs were yellow, the body of the rockets were orange with white highlights and the nose of the rocket was yellow with white highlights, outlined in black; and the streaks were silver with black markings.

A modification to the insignia was approved by CNO on 10 April 1946. Colors for this insignia were: a shield with a white background outlined in black and red; the cannon and bomb were black with green highlights; the eye and teeth were yellow; the neck and wings were red with yellow highlights and black markings; the legs and rocket were red with yellow



*A modification to the squadron's first insignia was approved for use in 1946.*

highlights and black outlines and the nose of the rockets were yellow with green highlights and black outlines; the streaks were yellow with black markings.

### *Chronology of Significant Events*

Oct 1945: The squadron participated in a 1200 plane fly over of New York City in honor of Navy Day.

### *Home Port Assignments*

<i>Location</i>	<i>Assignment Date</i>
NAAS Manteo	26 Mar 1945
NAS Wildwood	07 Apr 1945
NAAS Oceana	31 May 1945
NAS Norfolk	Jul 1946
NAS Alameda	07 Aug 1946

### *Commanding Officers*

	<i>Date Assumed Command</i>
LT J. W. Aulson	26 Mar 1945
LT Leonard Robinson	16 Apr 1945
LCDR Francis D. McGaffigan	26 Nov 1945
LCDR Robert J. Celustka	06 Sep 1946
LCDR Philip W. Cobb	15 Nov 1946
LCDR John B. Howland	10 Jan 1948
LCDR Charles N. Conatser	19 Nov 1948

### *Aircraft Assignments*

<i>Type of Aircraft</i>	<i>Date Type First Received</i>
SB2C-4E	Apr 1945
SB2C-5	Jun 1945
AD-2	08 Jul 1948



**Major Overseas Deployments**

<i>Date of Departure</i>	<i>Date of Return</i>	<i>Air Wing</i>	<i>Carrier</i>	<i>Type of Aircraft</i>	<i>Area of Operation</i>
31 Mar 1947	08 Oct 1947	CVAG-15	CV 36	SB2C-5	WestPac

**Air Wing Assignments**

<i>Air Wing</i>	<i>Tail Code</i>	<i>Assignment Date</i>
CVG-153/CVAG-15/CVG-15*	B/A†	26 Mar 1945

\* CVG-153 was redesignated CVAG-15 on 15 November 1946. CVAG-15 was redesignated CVG-15 on 1 September 1948.

† The tail code B was assigned to CVAG-15 on 12 December 1946 and changed to A on 4 August 1948.



*Squadron personnel in November 1949 with an AD-2 in the background; CO was Lieutenant Commander Charles N. Conatser.*

## VA-155

### Lineage

Established as Torpedo Squadron ONE HUNDRED FIFTY THREE (VT-153) on 26 March 1945.

Redesignated Attack Squadron SIXTEEN A (VA-16A) on 15 November 1946.

Redesignated Attack Squadron ONE HUNDRED FIFTY FIVE (VA-155) on 15 July 1948.

Disestablished on 30 November 1949. The first squadron to be assigned the VA-155 designation.

### Squadron Insignia and Nickname

The squadron's first insignia was approved by CNO on 11 February 1946. Colors for the gremlin riding a torpedo were: a light green background encircled by yellow stars outlined in black; the gremlin's hat was red with black top and yellow center; his face was shaded green, red and orange with pale blue eyes and black pupils, he had tan ears and a red tongue, pale blue wings and light orange arms; lavender jacket with yellow stripes and red buttons, black belt with a red and black buckle, green trousers with light purple stockings and brown shoes with purple pompons; yellow torpedo with brown highlights, a blue nose and red snout, a green eyeball and black pupil, the teeth and



*The gremlin was the squadron's first insignia.*

lips were red, the tail was yellow and white with a black propeller; the reins were black and yellow and the lettering was black, outlined in yellow.



*This insignia was approved for the squadron following its redesignation to VA-16A.*

Following the squadron's redesignation, a new insignia



*The skull and cobra was the third insignia used by the squadron.*

was approved by CNO on 12 June 1947. Colors for the caricature of the two TBFs was: a yellow sky and light green ocean background; blue TBFs with yellow lettering; red was used for the rockets, lightning bolts, and the mouth and eyes of the TBFs, the radome was light green; the cloud and hands of the TBFs were white; all other details were black, such as the prop hubs, music notes and ship silhouettes.

The squadron's next insignia was approved by CNO on 18 February 1949. Colors for the skull and cobra design were: a red background, white skull, and yellow cobra.

Nickname: unknown.

### Chronology of Significant Events

**Mar–Oct 1947:** During the squadron's deployment to the western Pacific, three of its aircraft were equipped as ASW planes, giving the squadron an ASW mission as well as attack.

### Home Port Assignments

Location	Assignment Date
NAAF Lewiston	26 Mar 1945
NAAS Oceana	01 Jun 1945
NAS Norfolk	02 Jul 1946
NAS Alameda	08 Aug 1946

### Commanding Officers

	Date Assumed Command
LT Harlan C. McFadden, Jr. (acting)	26 Mar 1945
LCDR Frederick G. Lewis	06 Apr 1945
LCDR Richard D. King (acting)	26 Jun 1946
LCDR Gaylord T. Forrest	03 Jul 1946
LCDR Gerald R. Stablein	10 Jan 1948
LCDR Don L. Ely	Jan 1949

### Aircraft Assignment

Type of Aircraft	Date Type First Received
TBM-3E	30 Mar 1945
TBM-3Q	Apr 1946
TBM-3W	Apr 1947
AD-2	19 Jul 1948

**Major Overseas Deployments**

<i>Date of Departure</i>	<i>Date of Return</i>	<i>Air Wing</i>	<i>Carrier</i>	<i>Type of Aircraft</i>	<i>Area of Operation</i>
31 Mar 1947	08 Oct 1947	CVAG-15	CV 36	TBM-3E/3Q/3W	WestPac

**Air Wing Assignments**

<i>Air Wing</i>	<i>Tail Code</i>	<i>Assignment Date</i>
CVG-153/CVAG-15/CVG-15*	B/A†	26 Mar 1945

\* CVG-153 was redesignated CVAG-15 on 15 November 1946. CVAG-15 was redesignated CVG-15 on 1 September 1948.

† The tail code B was assigned to CVAG-15 on 12 December 1946 and changed to A on 4 August 1948.



*Squadron personnel with TBM-3E in the background, circa 1945. CO was Lieutenant Commander Frederick G. Lewis.*

## SECOND VA-155

### Lineage

Established as Reserve Attack Squadron SEVENTY ONE E (VA-71E) in 1946.

Redesignated Reserve Attack Squadron FIFTY EIGHT A (VA-58A) on 1 October 1948.

Redesignated Reserve Composite Squadron SEVEN HUNDRED TWENTY TWO (VC-722) on 1 November 1949.

Redesignated Reserve Attack Squadron SEVEN HUNDRED TWENTY EIGHT (VA-728) on 1 April 1950.

Called to active duty as Attack Squadron SEVEN HUNDRED TWENTY EIGHT (VA-728) on 1 February 1951.

Redesignated Attack Squadron ONE HUNDRED FIFTY FIVE (VA-155) on 4 February 1953.

Disestablished on 30 September 1977. The second squadron to be assigned the VA-155 designation.

### Squadron Insignia and Nickname

The squadron's first insignia was approved by CNO on 23 September 1952. A photograph of the approved



*An artist's rendition of the squadron's first insignia design.*

design was not available. Colors and description of the insignia were: a silver-gray disk with a red border; a yellow-winged white and red lightening flash in front of a black cloud.

A new insignia was adopted by the squadron in 1953 following its redesignation. There is no official approval date for this insignia. The insignia adopted was the skull and snake design used by the first VA-155. On 8 July 1959, CNO approved a modification to the skull and snake insignia that included the addition of two diagonal stripes. Colors for this insignia were: a red background outlined in green; a white banner, outlined in green with black lettering; the skull was white with black markings; the snake's upper body was a salmon color with black lines, its head was green with white eyes and black pupils, the coiled



*The squadron's second insignia adopted the skull and cobra design used by the first VA-155.*



*A modification was made to the skull and cobra design in 1959, adding diagonal stripes.*

part of the snake was greenish black; and the two diagonal lines were green.

Sometime in the 1960s the squadron used an unofficial insignia with the head of a fox as its design.

Nickname: Silver Fox, early 1960s–1977.

### Chronology of Significant Events

**Oct 1951:** The squadron engaged in combat operations, flying its first sorties over Korea.

**Feb 1955:** Squadron aircraft flew sorties in support of the evacuation of Chinese Nationalists from the Tachen Islands.

**21 Aug–11 Sep 1958:** The squadron flew sorties in the Taiwan Straits after the Chinese Communists bombarded Quemoy Island.

**Jan 1961:** *Coral Sea* (CVA 43), with VA-155 embarked, operated in the South China Sea after Pathet Lao forces captured strategic positions in Laos.

**7 and 11 Feb 1965:** The squadron participated in Flaming Dart I and II, reprisal strikes against targets in North Vietnam following a Viet Cong attack on the American advisors compound at Pleiku and the American billet in Qui Nhon, South Vietnam.

**Mar 1965:** The squadron began participation in Rolling Thunder operations, the bombing of military targets in North Vietnam.

**May 1966:** VA-155 was the first A-4 squadron deploying to Vietnam using a new camouflage paint scheme nicknamed the "Flying Mulberrybushes." The new paint scheme and colors were expected to reduce battle damage by making the aircraft more difficult to detect visually.

**1 Jul 1966:** The squadron's commanding officer, Commander C. H. Peters, was killed in action while leading an attack on petroleum facilities at Duong Nham, North Vietnam.

**20 Oct 1967:** Squadron aircraft sighted six North Vietnamese PT boats near Thanh Hoa and engaged the boats. Four of the PT boats were sunk, one was damaged and the sixth escaped, seeking refuge in the mouth of the river near Thanh Hoa.

**25 Nov 1967:** Commander W. H. Searfus, the squadron's commanding officer, was lost at sea follow-

ing a flight deck accident in which his aircraft was lost over the side of the carrier.

**Mar 1968:** *Coral Sea* (CVA 43), with VA-155 embarked, operated on station off the coast of Korea following the capture of *Pueblo* (AGER 2) in January by North Korea.

**Apr 1969:** Following the shoot down of a Navy EC-121 aircraft by the North Koreans on 15 April, *Ranger* (CVA 61), with VA-155 embarked, left Yankee Station and proceeded to the Sea of Japan for operations off the coast of Korea.

**21 Nov 1970:** The squadron flew missions in support of an attempt to rescue American prisoners-of-war at the Son Tay prisoner compound, 20 miles west of Hanoi.

**Feb 1973:** Following the cease fire with North Vietnam, the squadron flew combat missions in Laos until a cease fire was signed with that country on 22 February 1973.

**Nov 1973:** *Oriskany* (CVA 34), with VA-155 embarked, departed from operations in the South China Sea to relieve *Hancock* (CVA 19) on station in the Arabian Sea due to the unsettled conditions following the Yom Kippur War in the Middle East.



*A squadron AD-4 launches from Antietam (CV 36) during their 1951-1952 combat cruise to Korea.*

### Home Port Assignments

Location	Assignment Date
NAS Glenview	1946
NAS Alameda	1951
NALF Santa Rosa	May 1952*
NAS Moffett Field	25 Aug 1952
NAS Lemoore	21 Aug 1961

\* Temporary assignment for training and reforming following its return from a combat tour in Korea.

### Commanding Officers

	Date Assumed Command
LCDR Soule T. Bitting	29 Aug 1946
LCDR B. K. Harrison (acting)	May 1952
LCDR Raymond S. Osterhoudt	08 Aug 1952
LCDR Frank R. West	Oct 1953
LCDR Jack B. Jones	21 Mar 1955
CDR Henry E. Clark	10 Dec 1956
CDR Deforest Q. Joralmon	29 Oct 1958
CDR Robert E. McElwee	Feb 1960
CDR Ira K. Kruger	04 Aug 1961
CDR Patrick F. Cunningham	31 Jul 1962
CDR T. B. Russell, Jr.	27 Jun 1963
CDR J. H. Harris	17 Jul 1964
CDR J. B. Morin	1965
CDR Charles H. Peters	1966
CDR E. W. Ingley	11 Jul 1966
CDR William H. Searfus	Jun 1967
CDR David J. Sperling	Dec 1967
CDR Robert F. Reynolds, Jr.	07 Dec 1968
CDR Edwin C. Adamson, Jr.	24 Oct 1969
CDR James H. Mauldin	28 Aug 1970
CDR Markley R. Seibert	1971
CDR Dean E. Cramer	02 Jun 1972
CDR Robert L. Leuschner, Jr.	07 Jun 1973
CDR Larry E. Kaufman	17 Jul 1974
CDR Robert D. Miller	24 Oct 1975
CDR Robert C. Kaup	05 Jan 1977

### Aircraft Assignment

Type of Aircraft	Date Type First Received
SB2C/TBM/AM	*
AD-1	1951
AD-2	1951
AD-4	1951
AD-4L	1951
AD-4Q	1951
AD-4NA	26 Jul 1952
AD-6	Nov 1953
AD-7	Nov 1956
A4D-2/A-4B†	08 Oct 1958
A-4E	Dec 1963
A-4F	10 Apr 1968
A-7B	29 Sep 1969

\* During the squadron's Reserve duty between 1946 and its activation in February 1951, it most likely flew SB2Cs, TBMs and/or AMs.

† The A4D-2 designation was changed to A-4B in 1962.



Two squadron A-4E Skyhawks return to Coral Sea (CVA 43) following a mission over Vietnam, 1965.

### Major Overseas Deployments

<i>Date of Departure</i>	<i>Date of Return</i>	<i>Air Wing</i>	<i>Carrier</i>	<i>Type of Aircraft</i>	<i>Area of Operation</i>
08 Sep 1951	02 May 1952	CVG-15	CV 36	AD-4/L/Q & AD-2	Korea
24 Jan 1953	21 Sep 1953	CVG-15	CVA 37	AD-4NA	Korea/WestPac
01 Jul 1954	28 Feb 1955	CVG-15	CVA 10	AD-6	WestPac
23 Apr 1956	15 Oct 1956	CVG-15	CVA 18	AD-6	WestPac
15 Feb 1958	02 Oct 1958	CVG-15	CVA 19	AD-7	WestPac
01 Aug 1959	18 Jan 1960	CVG-15	CVA 19	A4D-2	WestPac
19 Sep 1960	27 May 1961	CVG-15	CVA 43	A4D-2	WestPac
12 Dec 1961	17 Jul 1962	CVG-15	CVA 43	A4D-2	WestPac
03 Apr 1963	25 Nov 1963	CVG-15	CVA 43	A-4B	WestPac
07 Dec 1964	01 Nov 1965	CVW-15	CVA 43	A-4E	WestPac/Vietnam
12 May 1966	03 Dec 1966	CVW-15	CVA 64	A-4E	WestPac/Vietnam
26 Jul 1967	06 Apr 1968	CVW-15	CVA 43	A-4E	WestPac/Vietnam
26 Oct 1968	17 May 1969	CVW-2	CVA 61	A-4F	WestPac/Vietnam
14 May 1970	10 Dec 1970	CVW-19	CVA 34	A-7B	WestPac/Vietnam
14 May 1971	18 Dec 1971	CVW-19	CVA 34	A-7B	WestPac/Vietnam
05 Jun 1972	30 Mar 1973	CVW-19	CVA 34	A-7B	WestPac/Vietnam
18 Oct 1973	05 Jun 1974	CVW-19	CVA 34	A-7B	WestPac/IO
16 Sep 1975	03 Mar 1976	CVW-19	CV 34	A-7B	WestPac
04 Oct 1976	21 Apr 1977	CVW-19	CV 42	A-7B	Med

*A formation of squadron A-4F Skyhawks, circa 1968.*



**Air Wing Assignments**

<i>Air Wing</i>	<i>Tail Code</i>	<i>Assignment Date</i>
CVG-15/CVW-15†	H/NL*	01 Apr 1951
CVW-16	AH	Apr 1968
CVW-2	NE	12 Sep 1968
CVW-12‡		24 Jun 1969
CVW-19	NM	22 Nov 1969

\* The tail code was changed from H to NL in 1957. The effective date for this change was most likely the beginning of FY 58 (1 July 1957).

† CVG-15 was redesignated CVW-15 when Carrier Air Groups (CVG) were redesignated Carrier Air Wings (CVW) on 20 December 1963.

‡ When the squadron was assigned to CVW-12, it operated under the control of VA-122 while undergoing training for the transition to the A-7 Corsair II.

**Unit Awards Received—Continued**

<i>Unit Award</i>	<i>Inclusive Dates Covering Unit Award</i>		
MUC	07 Feb 1965	18 Oct 1965	
	29 May 1966	24 Nov 1966	
	13 Aug 1967	19 Feb 1968	
	29 Nov 1968	10 May 1969	
	01 Jun 1970	09 Dec 1970	
	28 Jun 1972	06 Mar 1973	
	RVNGC	12 Oct 1965	
		21 Jun 1966	22 Jun 1966
		23 Nov 1967	
		02 Dec 1967	
04 Dec 1967			
20 Dec 1967		22 Dec 1967	
20 Jan 1968			
23 Jan 1968		27 Jan 1968	
29 Jan 1968		19 Feb 1968	
07 Jan 1969		30 Jan 1969	
VNSM	15 Feb 1969	16 Mar 1969	
	04 Apr 1969	14 Apr 1969	
	04 Jul 1965	24 Jul 1965	
	11 Aug 1965	11 Sep 1965	
	21 Sep 1965	15 Oct 1965	
	14 Jun 1966	13 Jul 1966	
	27 Jul 1966	31 Aug 1966	
	08 Sep 1966	01 Oct 1966	
	19 Oct 1966	09 Nov 1966	
	26 Aug 1967	01 Oct 1967	
	12 Oct 1967	28 Oct 1967	
	04 Nov 1967	05 Nov 1967	
	11 Nov 1967	08 Dec 1967	
	16 Dec 1967	07 Jan 1968	
	15 Jan 1968	21 Feb 1968	
07 Jan 1969	30 Jan 1969		
NUC	15 Feb 1969	16 Mar 1969	
	04 Apr 1969	17 Apr 1969	
	13 Jun 1970	29 Jun 1970	
	12 Jul 1970	22 Jul 1970	

**Unit Awards Received**

<i>Unit Award</i>	<i>Inclusive Dates Covering Unit Award</i>		
KSM	04 Oct 1951	15 Apr 1952	
	27 Feb 1953	16 May 1953	
	29 May 1953	07 Sep 1953	
	AFEM	26 Aug 1958	07 Sep 1958
		14 Sep 1959	17 Sep 1959
		25 Apr 1961	28 Apr 1961
		30 Apr 1961	01 May 1961
		04 May 1961	09 May 1961
		12 Jan 1962	19 Jan 1962
		24 Jan 1962	27 Jan 1962
02 Feb 1965	05 Mar 1965		
16 Mar 1965	17 Apr 1965		
02 May 1965	28 May 1965		
23 Jun 1965	03 Jul 1965		
23 Jan 1968	22 Mar 1968		
20 Mar 1969	22 Mar 1969		
20 Apr 1969	27 Apr 1969		
NUC	13 Mar 1953	15 May 1953	
	11 Jun 1953	27 Jul 1953	

**Unit Awards Received—Continued**

<i>Unit Award</i>	<i>Inclusive Dates Covering Unit Award</i>	
	02 Aug 1970	26 Aug 1970
	17 Sep 1970	13 Oct 1970
	06 Nov 1970	23 Nov 1970
	15 Jun 1971	10 Jul 1971
	24 Jul 1971	07 Aug 1971
	03 Sep 1971	27 Sep 1971
	29 Oct 1971	21 Nov 1971

**Unit Awards Received—Continued**

<i>Unit Award</i>	<i>Inclusive Dates Covering Unit Award</i>	
	26 Jun 1972	23 Jul 1972
	16 Aug 1972	01 Sep 1972
	11 Sep 1972	28 Sep 1972
	08 Oct 1972	31 Oct 1972
	24 Nov 1972	18 Dec 1972
	27 Dec 1972	31 Jan 1973
	10 Feb 1973	06 Mar 1973



*A formation of squadron A-7B Corsair IIs in late 1969.*



## THIRD VA-155

### Lineage

Established as Attack Squadron ONE HUNDRED FIFTY FIVE (VA-155) on 1 September 1987.

Disestablished on 30 April 1993. The third squadron to be assigned the VA-155 designation.

### Squadron Insignia and Nickname

The squadron's insignia was approved by CNO on 24 July 1987. Colors for the Silver Fox insignia are as



The fox insignia used by the squadron.

follows: the circular design is outlined in silver with the upper background black and lower background blue with light blue highlights; yellow star, lightning bolt, moon, and wolf's pupils; silver wolf with black markings and outlined in white; and a silver scroll, outlined in black with black lettering.

Nickname: Silver Foxes, 1987–1993.

### Chronology of Significant Events

**15 August–8 October 1988:** *Independence* (CV 62), with VA-155 embarked, conducted a change of home port transit from Norfolk to San Diego via Cape Horn. During the transit numerous air power demonstrations were conducted for dignitaries from various South American countries.

**17 Jan 1991:** The squadron conducted its first combat operations. VA-155's commanding officer, Commander Sweigart, led Air Wing Two's aircraft in its first strike against Iraq.

**18 Jan 1991:** The squadron suffered its first and only loss during the war with Iraq when one of its A-6E Intruders was shot down while on a mining sortie by the Um Qasr Naval Base in Iraq.

**28 Feb 1991:** *Ranger's* last combat strike of the Gulf War was launched and led by a VA-155 aircraft. During the 43 day Gulf War the squadron flew 1,388.4 hours, a total of 635 sorties, and delivered 2,289,940 pounds of ordnance on Iraqi military targets.

**Sep–Dec 1992:** Squadron aircraft flew sorties in support of Operation Southern Watch, flights over southern Iraq south of the 32nd parallel to ensure Iraq was adhering to United Nations sanctions.

**Dec 1992:** The squadron participated in Operation Restore Hope, flying sorties in support of the humanitarian relief effort in Somalia.

### Home Port Assignments

Location	Assignment Date
NAS Whidbey Island	01 Sep 1987

### Commanding Officers

	Date Assumed Command
CDR Jack J. Samar	01 Sep 1987
CDR Kenneth R. Zimmerman	12 Jan 1989
CDR Frank Sweigart	29 Jun 1990
CDR Larry J. Munns	12 Sep 1991

### Aircraft Assignment

Type of Aircraft	Date Type First Received
KA-6D	16 Nov 1987
A-6E	Dec 1987

### Major Overseas Deployments

Date of Departure	Date of Return	Air Wing	Carrier	Type of Aircraft	Area of Operation
08 Dec 1990	09 Jun 1991	CVW-2	CV 61	A-6E	WestPac/IO/ Persian Gulf
01 Aug 1992	31 Jan 1993	CVW-2	CV 61	A-6E	WestPac/IO/ Persian Gulf

**Air Wing Assignments**

<i>Air Wing</i>	<i>Tail Code</i>	<i>Assignment Date</i>
CVW-10	NM	01 Dec 1987
CVW-17	AA	01 May 1988
CVW-2	NE	01 Oct 1989

**Unit Awards Received**

<i>Unit Award</i>	<i>Inclusive Dates Covering Unit Award</i>	
MUC	04 Sep 1987	03 Sep 1988
NUC	17 Jan 1991	07 Feb 1991
SASM	13 Jan 1991	19 Apr 1991
KLM	17 Jan 1991	07 Feb 1991
NAVE	01 Jan 1992	31 Dec 1992



*A squadron A-6E Intruder loaded with weapons, 1990.*

## VA-163

### Lineage

Established as Attack Squadron ONE HUNDRED SIXTY THREE (VA-163) on 1 September 1960.

Placed on inactive status on 1 April 1969 but maintained on the Naval Aeronautical Organization's list of designated squadrons. While inactive, no aircraft and only 1 administrative person was assigned to the squadron. VA-163 was removed from the Naval Aeronautical Organization list on 1 July 1971. The squadron probably was placed in an inactive status due to manpower and aircraft availability while awaiting transition to the A-6 Intruder.

Disestablished on 1 July 1971. The first squadron to be assigned the VA-163 designation.

### Squadron Insignia and Nickname

The squadron's insignia was approved by CNO on 31 January 1961. Colors for the insignia were: a light



The squadron's one and only insignia.

blue background with a white border outlined in black; the shield had a yellow border outlined in black; the background in the upper left quarter of the shield was dark blue with a yellow crescent moon and white star; the upper right quarter had a light blue background with a yellow moon and white cloud, outlined in black; the lower left quarter had a light blue background and the waves were a medium blue with white caps, outlined in black; the lower right quarter had a light blue background with snow capped dark blue mountains; the center of the shield had a square yellow box with black electron rings; the scroll was light blue outlined in black and had white lettering.

Nickname: Saints, 1960–1971.

### Chronology of Significant Events

Nov 1963: *Oriskany* (CVA 34), with VA-163 embarked, operated in the South China Sea during a crisis in South Vietnam and the coup that overthrew President Diem.

Jun 1965: The squadron's commanding officer, Commander Jenkins, led the first major POL (petroleum, oil, lubricants) strike of the war against the Dam Dinh, North Vietnam storage facility.

7 Nov 1965: Lieutenant Commander Charles G.

Wack was awarded the Silver Star for his action in leading a sortie against SAM sites south of Nam Dinh, North Vietnam. He pressed his attack even though his aircraft was badly damaged by anti-aircraft fire and successfully completed his mission before being forced to eject from the aircraft when it caught fire.

13 Nov 1965: Commander H. T. Jenkins, the squadron's commanding officer, was shot down while conducting an armed reconnaissance mission a few miles north of the DMZ and was captured. He remained a POW until his release in February 1973.

23 Jul 1966: During a successful POL mission over Vinh, North Vietnam, Commander W. F. Foster's aircraft was hit by anti-aircraft fire and he suffered the loss of his right arm. Using only his left hand, he piloted his crippled aircraft out to sea and ejected over the Gulf of Tonkin, where he was rescued. He was awarded the Silver Star for his actions.

26 Oct 1966: A major fire broke out in *Oriskany* on Yankee Station. The squadron lost four officers in the fire. Several squadron personnel received awards for their heroic actions during the fire.

21 Aug 1967: Commander B. W. Compton, Jr., the squadron's commanding officer, was awarded the Navy Cross for his actions as a strike leader of a major coordinated air attack against the Hanoi Thermal Power Plant.

### Home Port Assignments

Location	Assignment Date
NAS Cecil Field	01 Sep 1960
NAS Lemoore	26 Sep 1961

### Commanding Officers

	Date Assumed Command
CDR Jack M. Manherz	01 Sep 1960
CDR D. V. Marshall, Jr.	01 Sep 1961
CDR M. D. Short	14 Oct 1962
CDR Jarl J. Diffendorfer	05 Feb 1964
CDR Harry T. Jenkins, Jr.	30 Dec 1964
CDR Wynn F. Foster	13 Nov 1965
CDR Ronald H. Caldwell	30 Jul 1966
CDR Bryan W. Compton, Jr.	10 Jul 1967
CDR Elbert D. Lighter	10 Jul 1968

### Aircraft Assignment

Type of Aircraft	Date Type First Received
A4D-2/A-4B*	03 Oct 1960
A-4E	Mar 1964

\* The A4D-2 designation was changed to A-4B in 1962.

**Major Overseas Deployments**

<i>Date of Departure</i>	<i>Date of Return</i>	<i>Air Wing</i>	<i>Carrier</i>	<i>Type of Aircraft</i>	<i>Area of Operation</i>
07 Jun 1962	17 Dec 1962	CVG-16	CVA 34	A4D-2	WestPac
01 Aug 1963	10 Mar 1964	CVW-16	CVA 34	A-4B	WestPac
05 Apr 1965	16 Dec 1965	CVW-16	CVA 34	A-4E	WestPac/Vietnam
26 May 1966	16 Nov 1966	CVW-16	CVA 34	A-4E	WestPac/Vietnam
16 Jun 1967	31 Jan 1968	CVW-16	CVA 34	A-4E	WestPac/Vietnam
18 Jul 1968	03 Mar 1969	CVW-21	CVA 19	A-4E	WestPac/Vietnam

**Air Wing Assignments**

<i>Air Wing</i>	<i>Tail Code</i>	<i>Assignment Date</i>
CVG-16/CVW-16*	AH	01 Sep 1960
CVW-21	NP	01 Mar 1968

\* CVG-16 was redesignated CVW-16 when Carrier Air Groups (CVG) were redesignated Carrier Air Wings (CVW) on 20 December 1963.

**Unit Awards Received**

<i>Unit Award</i>	<i>Inclusive Dates Covering Unit Award</i>	
AFEM	05 Sep 1963	13 Sep 1963
	03 Nov 1963	08 Nov 1963
	07 May 1965	02 Jun 1965
	10 Jun 1965	03 Jul 1965
	17 Sep 1965	18 Sep 1965
NUC	02 Dec 1968	04 Dec 1968
	10 May 1965	06 Dec 1965
	12 Jun 1966	01 Nov 1966
	14 Jul 1967	12 Jan 1968
RVNGC	01 Aug 1968	22 Feb 1969
	02 Oct 1965	
	30 Oct 1965	
	01 Nov 1965	
	03 Nov 1965	
	07 Nov 1965	
	11 Nov 1965	12 Nov 1965
	06 Jul 1966	07 Jul 1966
	26 Sep 1968	
	29 Sep 1968	
09 Oct 1968	11 Oct 1968	

**Unit Awards Received—Continued**

<i>Unit Award</i>	<i>Inclusive Dates Covering Unit Award</i>	
VNSM	13 Oct 1968	
	02 Nov 1968	
	07 Nov 1968	08 Nov 1968
	10 Nov 1968	11 Nov 1968
	13 Nov 1968	19 Nov 1968
	21 Nov 1968	26 Nov 1968
	21 Dec 1968	24 Dec 1968
	26 Dec 1968	28 Dec 1968
	30 Dec 1968	
	01 Jan 1969	03 Jan 1969
	07 Jan 1969	14 Jan 1969
	31 Jan 1969	08 Feb 1969
	04 Jul 1965	18 Jul 1965
	09 Aug 1965	11 Sep 1965
	30 Sep 1965	19 Oct 1965
28 Oct 1965	27 Nov 1965	
29 Jun 1966	29 Jul 1966	
06 Aug 1966	08 Sep 1966	
23 Sep 1966	26 Oct 1966	
13 Jul 1967	08 Aug 1967	
17 Aug 1967	30 Sep 1967	
04 Oct 1967	03 Nov 1967	
19 Nov 1967	17 Dec 1967	
30 Dec 1967	13 Jan 1968	
21 Aug 1968	04 Sep 1968	
13 Sep 1968	15 Oct 1968	
23 Oct 1968	28 Nov 1968	
20 Dec 1968	15 Jan 1969	
29 Jan 1969	10 Feb 1969	



*A formation of squadron A-4 Skyhawks.*

## VA-164

### Lineage

Established as Attack Squadron ONE HUNDRED SIXTY FOUR (VA-164) on 1 September 1960.

Disestablished on 12 December 1975. The first squadron to be assigned the VA-164 designation.

### Squadron Insignia and Nickname

The squadron's insignia was approved by CNO on 24 May 1961. Colors for the Ghost rider insignia were: a black background outlined in black and white; the ghost rider was gold with black markings; the winged horse, diamond and scrolls were silver with black markings or lettering; the smoke/cloud was white with black markings; the flames were red, yellow, orange, blue, and green; and the aerodynamic (triangular) design was orange.



The squadron's ghost rider insignia.

Nickname: Ghost-riders, 1961–1975.

### Chronology of Significant Events

Nov 1963: *Oriskany* (CVA 34), with VA-164 embarked, operated in the South China Sea during a crisis in South Vietnam and the coup that overthrew President Diem.

5 May 1965: The squadron flew its first combat sortie. From May through July 1965, it flew close air support missions in South Vietnam.

7 Nov 1965: The squadron's commanding officer, Commander J. D. Shaw, was awarded the Silver Star for successfully leading a strike against a SAM site in North Vietnam.

26 Oct 1966: A major fire broke out in *Oriskany* on Yankee Station. The squadron lost four officers in the fire. Several squadron personnel received awards for their heroic actions during the fire.

Oct 1967: Commander D. F. Mow, the squadron's commanding officer, was awarded the Silver Star for his actions during a combat mission over North Vietnam.

Mar 1970: The squadron completed the last line period of its fifth combat deployment to Vietnam. This was the squadron's first combat deployment without losing a pilot.

Apr 1972: The squadron participated in Operation Freedom Train, tactical air sorties against military and logistic targets in the southern part of North Vietnam.

It also provided close air support for forces in South Vietnam following a massive invasion by North Vietnam.

May 1972: Squadron aircraft participated in the early phase of operation Linebacker I, heavy air strikes against targets in North Vietnam.

Aug 1972: TA-4s acquired by VA-164 from the Marine Corps at MCAS Iwakuni were used for the first time operationally in a combat role off a carrier.

Jun 1973: Missions were flown in support of Operation End Sweep, the clearing of mines in the territorial waters of North Vietnam.

Oct 1974: With the outbreak of war between Israel and Egypt and Syria the *Hancock* (CVA 19), with VA-164 embarked, was directed to leave Yankee Station and operate in the Arabian Sea and Gulf of Aden.

### Home Port Assignments

Location	Assignment Date
NAS Cecil Field	01 Sep 1960
NAS Lemoore	26 Sep 1961

### Commanding Officers

	Date Assumed Command
CDR Harlan D. Williams	01 Sep 1960
CDR Lloyd W. Moffit	05 Sep 1961
CDR C. A. Banks, Jr.	Oct 1962
CDR R. M. Netherland	21 Sep 1963
CDR J. W. Roberts	28 Aug 1964
CDR John D. Shaw	24 Jul 1965
CDR Paul H. Engel	26 Jun 1966
CDR Douglas F. Mow	31 May 1967
CDR William F. Span	04 Jul 1968
CDR Roy V. Hagberg	18 Jul 1969
CDR George L. Boaz	24 Jul 1970
CDR Ramsay (N) Lawson	08 Jul 1971
CDR Stanley R. Arthur	01 Jul 1972
CDR Fred J. Gosebrink	15 Jun 1973
CDR Frederick P. Meyers	30 May 1974

### Aircraft Assignment

Type of Aircraft	Date Type First Received
A4D-2/A-4B*	07 Oct 1960
A-4E	13 Mar 1964
A-4F	06 Apr 1969
TA-4F	08 Aug 1972

\* The A4D-2 designation was changed to A-4B in 1962.

**Major Overseas Deployments**

<i>Date of Departure</i>	<i>Date of Return</i>	<i>Air Wing</i>	<i>Carrier</i>	<i>Type of Aircraft</i>	<i>Area of Operation</i>
07 Jun 1962	17 Dec 1962	CVG-16	CVA 34	A4D-2	WestPac
01 Aug 1963	10 Mar 1964	CVW-16	CVA 34	A-4B	WestPac
05 Apr 1965	16 Dec 1965	CVW-16	CVA 34	A-4E	WestPac/Vietnam
26 May 1966	16 Nov 1966	CVW-16	CVA 34	A-4E	WestPac/Vietnam
16 Jun 1967	31 Jan 1968	CVW-16	CVA 34	A-4E	WestPac/Vietnam
18 Jul 1968	03 Mar 1969	CVW-21	CVA 19	A-4E	WestPac/Vietnam
02 Aug 1969	15 Apr 1970	CVW-21	CVA 19	A-4F	WestPac/Vietnam
22 Oct 1970	03 Jun 1971	CVW-21	CVA 19	A-4F	WestPac/Vietnam
07 Jan 1972	03 Oct 1972	CVW-21	CVA 19	A-4F & TA-4F	WestPac/Vietnam
08 May 1973	08 Jan 1974	CVW-21	CVA 19	A-4F & TA-4F	WestPac/IO
18 Mar 1975	20 Oct 1975	CVW-21	CV 19	A-4F & TA-4F	WestPac



*Two squadron A-4F Skyhawks in flight, 1973.*

**Air Wing Assignments**

<i>Air Wing</i>	<i>Tail Code</i>	<i>Assignment Date</i>
CVG-16/CVW-16*	AH	01 Sep 1960
CVW-21	NP	01 Mar 1968

\* CVG-16 was redesignated CVW-16 when Carrier Air Groups (CVG) were redesignated Carrier Air Wings (CVW) on 20 December 1963.

**Unit Awards Received**

<i>Unit Award</i>	<i>Inclusive Dates Covering Unit Award</i>		
NUC	10 May 1965	06 Dec 1965	
	12 Jun 1966	01 Nov 1966	
	14 Jul 1967	12 Jan 1968	
	01 Aug 1968	22 Feb 1969	
	08 Feb 1972	14 Sep 1972	
	01 Jul 1971	31 Dec 1972	
	05 Sep 1963	13 Sep 1963	
	03 Nov 1963	08 Nov 1963	
	07 May 1965	02 Jun 1965	
	10 Jun 1965	03 Jul 1965	
NAVE	17 Sep 1965	18 Sep 1965	
	02 Dec 1968	04 Dec 1968	
	30 Oct 1969		
	03 Jan 1970	08 Jan 1970	
	22 Feb 1970	25 Feb 1970	
	21 Aug 1969	31 Mar 1970	
	20 Nov 1970	07 May 1971	
	RVNGC	02 Oct 1965	
		30 Oct 1965	
		01 Nov 1965	
03 Nov 1965			
07 Nov 1965			
11 Nov 1965		12 Nov 1965	
06 Jul 1966		07 Jul 1966	
26 Sep 1968			
29 Sep 1968			
09 Oct 1968		11 Oct 1968	
13 Oct 1968			
02 Nov 1968			
07 Nov 1968		08 Nov 1968	
10 Nov 1968		11 Nov 1968	
13 Nov 1968		19 Nov 1968	

**Unit Awards Received—Continued**

<i>Unit Award</i>	<i>Inclusive Dates Covering Unit Award</i>	
VNSM	21 Nov 1968	26 Nov 1968
	21 Dec 1968	24 Dec 1968
	26 Dec 1968	28 Dec 1968
	30 Dec 1968	
	01 Jan 1969	03 Jan 1969
	07 Jan 1969	14 Jan 1969
	31 Jan 1969	08 Feb 1969
	01 Aug 1969	01 Sep 1969
	30 Mar 1972	15 Jul 1972
	04 Jul 1965	18 Jul 1965
	09 Aug 1965	11 Sep 1965
	30 Sep 1965	19 Oct 1965
	28 Oct 1965	27 Nov 1965
	29 Jun 1966	29 Jul 1966
	06 Aug 1966	08 Sep 1966
23 Sep 1966	26 Oct 1966	
13 Jul 1967	08 Aug 1967	
17 Aug 1967	30 Sep 1967	
04 Oct 1967	03 Nov 1967	
19 Nov 1967	17 Dec 1967	
30 Dec 1967	13 Jan 1968	
21 Aug 1968	04 Sep 1968	
13 Sep 1968	15 Oct 1968	
23 Oct 1968	28 Nov 1968	
20 Dec 1968	15 Jan 1969	
29 Jan 1969	10 Feb 1969	
31 Aug 1969	24 Sep 1969	
03 Oct 1969	27 Oct 1969	
24 Nov 1969	17 Dec 1969	
18 Jan 1970	11 Feb 1970	
09 Mar 1970	26 Mar 1970	
19 Nov 1970	08 Dec 1970	
29 Dec 1970	15 Jan 1971	
23 Jan 1971	20 Feb 1971	
09 Mar 1971	10 Apr 1971	
17 Apr 1971	04 May 1971	
07 Feb 1972	09 Mar 1972	
25 Mar 1972	02 May 1972	
11 May 1972	01 Jun 1972	
12 Jun 1972	14 Jul 1972	
24 Jul 1972	17 Aug 1972	
27 Aug 1972	14 Sep 1972	

## VA-165

### Lineage

Established as Attack Squadron ONE HUNDRED SIXTY FIVE (VA-165) on 1 September 1960.

The first squadron to be assigned the VA-165 designation.



*The squadron's first insignia.*

Similar device at one end; red electron rings circled the tailhook and the boomerang or wedge shaped device was green, outlined in black.

Sometime in the early 1960s, following the squadrons transfer to the west coast, a new insignia was adopted. There is no record of an approval date for this insignia. Colors for the insignia are: a silver background with green scrolls and outlined in black; gold lettering and compass star with black markings on the star; green boomerang outlined in black; and a white knight chessman with black markings.



*The squadron's second insignia had a more stylized design adopted sometime in the early 1960s.*

### Squadron Insignia and Nickname

The squadron's first insignia was approved by CNO on 24 May 1961. Colors for this insignia were: a silver background with a white scroll outlined in black, lettering on the scroll was green; brown map outlined in black; black and white tailhook with a red triangular

device at one end; red electron rings circled the tailhook and the boomerang or wedge shaped device was green, outlined in black. Sometime in the early 1960s, following the squadrons transfer to the west coast, a new insignia was adopted. There is no record of an approval date for this insignia. Colors for the insignia are: a silver background with green scrolls and outlined in black; gold lettering and compass star with black markings on the star; green boomerang outlined in black; and a white knight chessman with black markings.

Nickname: Boomers, mid 1960s to present.

### Chronology of Significant Events

**Nov 1963:** *Oriskany* (CVA 34), with VA-165 embarked, operated in the South China Sea during a crisis in South Vietnam and the coup that overthrew President Diem.

**Feb 1965:** The squadron began participation in combat operations over Laos.

**4 Apr 1966:** VA-165 deployed to Vietnam as a component of CVW-10 embarked in *Intrepid* (CVS 11). This was the first all attack air wing and the first to

deploy. Two squadrons flew the A-1 Skyraider and the other two squadrons flew the A-4 Skyhawk.

**26 Jan 1968:** The *Ranger* (CVA 62), with VA-165 embarked, while operating on Yankee Station, was ordered to the Sea of Japan following the capture of *Pueblo* (AGER 2) on 23 January by the North Koreans. *Ranger* and VA-165 operated in the area until relieved on 5 March 1968.

**Apr 1969:** Following the shoot down of a Navy EC-121 aircraft by the North Koreans on 15 April, *Ranger* (CVA 61), with VA-165 embarked, left Yankee Station and proceeded to the Sea of Japan for operations off the coast of Korea.

**26 May 1970:** The squadron's commanding officer, Commander F. M. Backman, flew the newest update version of the A-6 Intruder, the A-6C, into combat for the first time.

**Apr 1972:** The squadron participated in Operation Freedom Train, tactical air sorties against military and logistic targets in the southern part of North Vietnam. It also provided support for forces in South Vietnam following a massive invasion by North Vietnam on 1 April 1972.

**May 1972:** The squadron participated in the early phase of Operation Linebacker I, heavy air strikes against targets in North Vietnam above 20 degrees north latitude.

**Nov 1974:** VA-165, part of the CVW-9 team embarked on *Constellation* (CV 64), operated in the Persian Gulf. This was the first time in 26 years that an American carrier had entered and operated in the Persian Gulf.

**Mar 1979:** *Constellation* (CV 64), with VA-165 embarked, was ordered to make a high speed transit to the Indian Ocean from the Philippines in response to the conflict between North and South Yemen.

**Oct 1981:** The squadron was the first operational A-6 unit to deploy with a Harpoon missile capability.

**Jul-Aug 1983:** *Ranger*, with VA-165 embarked, was ordered to operate off the coast of Nicaragua in response to an unstable situation in Central America and the possible invasion of Honduras by Nicaragua.

**Oct 1983-Jan 1984:** *Ranger*, with VA-165 embarked, was extended on station in the Arabian Sea due to the Iranian threat to block oil exports from the Persian Gulf.

**Sep 1988:** *Nimitz* (CVN 68), with VA-165 embarked, operated in the Sea of Japan in support of the Summer Olympic Games in Seoul, Republic of Korea.

**Nov 1988:** Squadron aircraft participated in Earnest Will Operations, the escorting of reflagged Kuwaiti tankers through the Persian Gulf.





*A squadron AD-5 Skyraider at NAS Glenview, Illinois (Courtesy Fred Dickey Collection).*

**Home Port Assignments**

<i>Location</i>	<i>Assignment Date</i>
NAS Jacksonville	01 Sep 1960
NAS Moffett Field	07 Sep 1961
NAS Alameda	10 Mar 1964
NAS Whidbey Island	01 Jan 1967

**Commanding Officers**

	<i>Date Assumed Command</i>
CDR Robert M. Proshek	05 Nov 1976
CDR H. G. Sprouse	Feb 1978
CDR Ian K. Graham	22 Apr 1979
CDR Michael C. Scully	25 Jul 1980
CDR Paul S. Bloch	02 Oct 1981
CDR Gary C. Wasson	14 Jan 1983
CDR Robert T. Knowles	15 Jun 1984
CDR John C. Scrapper	31 Jan 1986
CDR Donald C. Brown	01 Aug 1987
CDR William H. Shurtleff IV	10 Dec 1988
CDR John W. Indorf, Jr.	23 May 1990

**Commanding Officers**

	<i>Date Assumed Command</i>
CDR Carl H. Yeagle	01 Sep 1960
CDR John E. Ford	25 Aug 1961
CDR R. Houck	1962
CDR L. L. Andrews, Jr.	02 Sep 1963
CDR R. E. Chamblair, Jr.	10 Apr 1964
CDR A. K. Knoizen	1965
CDR Harry D. Parode	1966
CDR William S. Jett III	22 Dec 1966
CDR Leland S. Kollmorgen	11 Jun 1968
CDR Fred M. Backman	27 Jun 1969
CDR Richard A. Zick	09 Jun 1970
CDR Thomas W. Conboy	17 Jun 1971
CDR James M. Seely	13 Jul 1972
CDR George C. Crater	21 Jun 1973
CDR Gary C. Caron	14 Jun 1974
CDR Samuel A. Belcher III	29 Aug 1975

**Aircraft Assignment**

<i>Type of Aircraft</i>	<i>Date Type First Received</i>
AD-6/A-1H*	04 Oct 1960
A-1J	Jun 1963
A-6A	May 1967
A-6B	Nov 1969
A-6C	27 Feb 1970
KA-6D	28 Mar 1971
A-6E	20 Jan 1975

\* The AD-6 designation was changed to A-1H in 1962.

**Major Overseas Deployments**

<i>Date of Departure</i>	<i>Date of Return</i>	<i>Air Wing</i>	<i>Carrier</i>	<i>Type of Aircraft</i>	<i>Area of Operation</i>
07 Jun 1962	17 Dec 1962	CVG-16	CVA 34	AD-6	WestPac
01 Aug 1963	10 Mar 1964	CVW-16	CVA 34	A-1H/J	WestPac

**Major Overseas Deployments**

<i>Date of Departure</i>	<i>Date of Return</i>	<i>Air Wing</i>	<i>Carrier</i>	<i>Type of Aircraft</i>	<i>Area of Operation</i>
07 Dec 1964	01 Nov 1965	CVW-15	CVA 43	A-1H/J	WestPac/Vietnam
04 Apr 1966	21 Nov 1966	CVW-10	CVS 11	A-1H	WestPac/Vietnam
04 Nov 1967	25 May 1968	CVW-2	CVA 61	A-6A	WestPac/Vietnam
26 Oct 1968	17 May 1969	CVW-2	CVA 61	A-6A	WestPac/Vietnam
10 Apr 1970	21 Dec 1970	CVW-9	CVA 66	A-6A/B/C	WestPac/Vietnam
01 Oct 1971	30 Jun 1972	CVW-9	CVA 64	A-6A & KA-6D	WestPac/Vietnam
05 Jan 1973	11 Oct 1973	CVW-9	CVA 64	A-6A & KA-6D	WestPac/Vietnam
21 Jun 1974	22 Dec 1974	CVW-9	CVA 64	A-6A & KA-6D	WestPac/IO
12 Apr 1977	21 Nov 1977	CVW-9	CV 64	A-6E & KA-6D	WestPac
26 Sep 1978	17 May 1979	CVW-9	CV 64	A-6E & KA-6D	WestPac/IO
26 Feb 1980	15 Oct 1980	CVW-9	CV 64	A-6E & KA-6D	WestPac/IO
20 Oct 1981	23 May 1982	CVW-9	CV 64	A-6E & KA-6D	WestPac/IO
15 Jul 1983	29 Feb 1984	CVW-9	CV 61	A-6E & KA-6D	CentralAmerica/ WestPac/IO
24 Jul 1985	21 Dec 1985	CVW-9	CV 63	A-6E & KA-6D	WestPac/IO
03 Jan 1987	29 Jun 1987	CVW-9	CV 63	A-6E & KA-6D	World Cruise
02 Sep 1988	27 Feb 1989	CVW-9	CVN 68	A-6E & KA-6D	WestPac/IO
15 Jun 1989	09 Jul 1989	CVW-9	CVN 68	A-6E & KA-6D	NorPac
12 Feb 1990	07 Apr 1990	CVW-9*	CV 64	A-6E & KA-6D	*

\* VA-165 was part of a composite CVW-9 that was embarked in *Constellation* (CV 64) for her home port change and transit from the east coast to the west coast via Cape Horn.



A squadron KA-6D Intruder refuels an F-14 Tomcat from VF-211.

**Air Wing Assignments**

<i>Air Wing</i>	<i>Tail Code</i>	<i>Assignment Date</i>
CVG-16/CVW-16*	AH	01 Sep 1960
CVW-15	NL	22 Jun 1964
CVW-10	AK	14 Mar 1966
COMFAIRALAMEDA/ CVW-15†		Nov 1966
COMFAIRWHIDBEY		01 Jan 1967
CVW-2	NE	16 Jun 1967
CVW-9	NG	02 Jul 1969

\* CVG-16 was redesignated CVW-16 when Carrier Air Groups (CVG) were redesignated Carrier Air Wings (CVW) on 20 December 1963.

† When VA-165 returned from its deployment to WestPac on 21 November 1966 it was assigned to CVW-15. However, CVW-15 was still on a WestPac cruise and did not return until 3 December 1966.

**Unit Awards Received**

<i>Unit Award</i>	<i>Inclusive Dates Covering Unit Award</i>	
NAVE	01 Jul 1968	31 Dec 1969
	01 Jan 1970	30 Jun 1971
	01 Jul 1974	31 Dec 1975
	01 Jan 1976	30 Jun 1977
	01 Jan 1985	30 Jun 1986
	01 Jul 1986	31 Dec 1987
MUC	03 Dec 1967	09 May 1968
	26 May 1970	08 Nov 1970
	12 Mar 1979	19 Apr 1979
	15 Jun 1984	27 Feb 1986
	Jan 1987	May 1987
AFEM	05 Sep 1963	13 Sep 1963

**Unit Awards Received**

<i>Unit Award</i>	<i>Inclusive Dates Covering Unit Award</i>	
	03 Nov 1963	08 Nov 1963
	02 Feb 1965	05 Mar 1965
	16 Mar 1965	11 Apr 1965
	02 May 1965	28 May 1965
	23 Jun 1965	03 Jul 1965
	23 Jan 1968	22 Mar 1968
	20 Mar 1969	22 Mar 1969
	20 Apr 1969	27 Apr 1969
	24 Sep 1970	26 Sep 1970
	02 Nov 1988	05 Dec 1988
NEM	12 Mar 1979	19 Apr 1979
	26 Apr 1980	04 Aug 1980
	12 Aug 1980	19 Aug 1980
NUC	07 Feb 1965	18 Oct 1965
	29 Nov 1968	10 May 1969
PUC	22 Oct 1971	13 Jun 1972
RVNGC	12 Oct 1965	
	30 Mar 1972	01 Jun 1972
VNSM	04 Jul 1965	24 Jul 1965
	11 Aug 1965	11 Sep 1965
	21 Sep 1965	15 Oct 1965
	15 May 1966	15 Jun 1966
	08 Jul 1966	10 Aug 1966
	01 Sep 1966	23 Sep 1966

**Unit Awards Received**

<i>Unit Award</i>	<i>Inclusive Dates Covering Unit Award</i>	
	02 Oct 1966	18 Oct 1966
	03 Dec 1967	29 Dec 1967
	06 Jan 1968	28 Jan 1968
	18 Mar 1968	12 Apr 1968
	21 Apr 1968	09 May 1968
	07 Jan 1969	30 Jan 1969
	15 Feb 1969	16 Mar 1969
	04 Apr 1969	17 Apr 1969
	17 May 1970	
	19 May 1970	
	24 May 1970	16 Jun 1970
	28 Jun 1970	13 Jul 1970
	20 Jul 1970	04 Aug 1970
	24 Aug 1970	18 Sep 1970
	13 Oct 1970	08 Nov 1970
	02 Nov 1971	22 Nov 1971
	29 Nov 1971	31 Dec 1971
	09 Jan 1972	03 Feb 1972
	09 Feb 1972	02 Mar 1972
	13 Mar 1972	23 Mar 1972
	07 Apr 1972	18 May 1972
	24 May 1972	25 May 1972
	31 May 1972	13 Jun 1972



*A squadron A-6E Intruder in flight, 1978.*

## VA-172

### Lineage

Established as Bomber Fighter Squadron EIGHTY TWO (VBF-82) on 20 August 1945.

Redesignated Fighter Squadron EIGHTEEN A (VF-18A) on 15 November 1946.

Redesignated Fighter Squadron ONE HUNDRED SEVENTY TWO (VF-172) on 11 August 1948.

Redesignated Attack Squadron ONE HUNDRED SEVENTY TWO (VA-172) on 1 November 1955.

Disestablished on 15 January 1971. The first squadron to be assigned the VA-172 designation.



*The design using the chess pieces was the squadron's first insignia.*

The chess piece insignia was used by the squadron until 19 October 1950 when CNO approved a new insignia. Colors for the new insignia were: a blue border outlined a red and white shield;



*The squadron adopted the blue bolts design as its second insignia.*

### Squadron Insignia and Nickname

The squadron's first insignia was approved by CNO on 12 June 1946. Colors for insignia were: a gold background outlined in grey with blue triangles; the knight and queen chess pieces were red with white highlights and the pawn and king were grey with white highlights.

Colors for the new insignia were: a blue border outlined a red and white shield; gold naval aviator wings with black markings; blue lightning bolt; and the lettering Blue Bolts was black.

Nickname: Check-mates, 1946–1950.

Blue Bolts, 1950–1971.

### Chronology of Significant Events

**28 Jan 1949:** Squadron aircraft, while secured to the flight deck and engines running, were used to assist in berthing *Midway* (CVB 41) in Augusta, Sicily. This procedure is known as operation Pinwheel.

**23 Aug 1951:** The squadron participated in its first combat sortie. This also marked the first use of the F2H-2 in combat.

**25 Aug 1951:** The squadron's F2H-2 aircraft, along

with F9Fs from VF-51, provided escort for 30 U.S. Air Force B-29 bombers raiding the marshalling yards at Rashin, North Korea.

**Nov-Dec 1956:** *Franklin D. Roosevelt* (CVA 42), with VA-172 embarked, was ordered to deploy and operate off the coast of Spain as a result of the Suez Canal crisis.

**Sep-Oct 1957:** A detachment of squadron's F2H-2 aircraft were embarked in *Tarawa* (CVS 40) to provide fighter support for the ASW carrier during a NATO exercise in the North Atlantic.

**Nov 1961:** VA-172, embarked in *Roosevelt*, operated off the coast of the Dominican Republic to support the newly established democratic government.

**May 1963:** *Roosevelt*, with VA-172 embarked, deployed to the Caribbean and operated off the coast of Haiti in response to a rebel attempt to overthrow the Haitian government.

**Jul-Sep 1963:** A detachment from the squadron was deployed aboard *Randolph* (CVS 15) to provide fighter coverage for the ASW Task Group during operations in the Caribbean Sea.

**8-29 Aug 1964:** *Roosevelt*, with VA-172 embarked, was ordered to operate in the vicinity of Cyprus after fighting escalated between Turkish and Greek forces on the island.

**Aug 1966:** The squadron commenced combat operations in Vietnam. These were its first combat sorties since the Korean War in 1952.

**2 Dec 1966:** The squadron's commanding officer, Commander Bruce A. Nystrom, was lost in a night reconnaissance mission over the Red River delta area in North Vietnam.



*A squadron F4U-4 Corsair traps aboard Coral Sea (CVB 43), 1948 (Courtesy Robert Lawson Collection).*

**Home Port Assignments**

<i>Location</i>	<i>Assignment Date</i>
NAS Alameda	20 Aug 1945
NAS Quonset Point	15 Jan 1946
NAAS Cecil Field	04 Mar 1949
NAS Jacksonville	24 Mar 1950
NAS Cecil Field	22 Feb 1958

**Commanding Officers**

<i>Date Assumed Command</i>	<i>Officer</i>
19 Dec 1961	CDR William S. Stewart
19 Dec 1962	CDR M. Blaylock
09 Dec 1963	CDR E. D. Herbert
08 Dec 1964	CDR K. A. Burrows
23 Dec 1965	CDR Bruce A. Nystrom
03 Dec 1966	CDR Robert D. Harris, Jr.
24 Nov 1967	CDR Thomas A. Francis
27 Nov 1968	CDR John D. Yamnicky
31 Oct 1969	CDR Conrad B. Olson

**Commanding Officers**

<i>Officer</i>	<i>Date Assumed Command</i>
LT Benjamin T. Pugh (acting)	20 Aug 1945
LCDR Jacob W. Onstott	10 Sep 1945
LCDR Pierre N. Charbonnet, Jr.	28 May 1946
LCDR V. P. de Poix	12 Feb 1948
LCDR C. A. Blouin	19 Apr 1950
LCDR Marvin E. Barnett	15 Mar 1951
LCDR James B. Cain	17 Jun 1952
LT R. P. McCloskey (acting)	04 Aug 1954
CDR Glenn G. Estes, Jr.	26 Aug 1954
CDR Robert M. McConnell, Jr.	31 Oct 1955
LCDR F. A. Fox (acting)	25 Apr 1957
CDR Robert J. Robison	10 Jun 1957
LCDR H. O. Cutler	25 Jul 1958
CDR Arthur Barker, Jr.	21 Sep 1959
CDR John D. Kidd	19 Dec 1960

**Aircraft Assignment**

<i>Type of Aircraft</i>	<i>Date Type First Received</i>
F6F	Aug 1945
F4U	06 Sep 1945
F8F	1946
FH-1	Mar 1949
F2H-1	May 1949
F2H-2	21 Jun 1950
F2H-4	13 Jan 1956
F2H-2B	Sep 1956
A4D-1	16 Dec 1957
A4D-2	May 1958
A4D-2N/A-4C*	06 Sep 1961

\* The A4D-2N designation was changed to A-4C in 1962.

**Major Overseas Deployments**

<i>Date of Departure</i>	<i>Date of Return</i>	<i>Air Wing</i>	<i>Carrier</i>	<i>Type of Aircraft</i>	<i>Area of Operation</i>
22 Oct 1946	21 Dec 1946	CVG-82*	CV 15	F4U-4	Med
02 Feb 1947	19 Mar 1947	CVAG-17	CV 15	F4U-4	EasternLant/Carib
07 Jun 1948	06 Aug 1948	CVG-17	CVB 43	F4U-4	Med/Carib
04 Jan 1949	05 Mar 1949	CVG-17	CVB 41	F4U-4	Med
09 Sep 1950	01 Feb 1951	CVG-17	CVB 43	F2H-2	Med
21 Jul 1951	25 Mar 1952	CVG-5	CV 9†	F2H-2	WestPac/Korea
26 Aug 1952	19 Dec 1952	CVG-17	CVA 42	F2H-2	NorLant/Med
16 Sep 1953	01 May 1954	CVG-17	CVA 18	F2H-2	World Cruise
05 Apr 1955	29 Sep 1955	CVG-17	CVA 43	F2H-2	Med
13 Feb 1959	01 Sep 1959	CVG-1	CVA 42	A4D-2	Med
28 Jan 1960	24 Aug 1960	CVG-1	CVA 42	A4D-2	Med
15 Feb 1961	28 Aug 1961	CVG-1	CVA 42	A4D-2	Med
19 Nov 1961	30 Nov 1961	CVG-1	CVA 42	A4D-2N	Carib
14 Sep 1962	22 Apr 1963	CVG-1	CVA 42	A-4C	Med
28 Apr 1964	22 Dec 1964	CVW-1	CVA 42‡	A-4C	Med
28 Jun 1965	17 Dec 1965	CVW-1	CVA 42	A-4C	Med
21 Jun 1966	21 Feb 1967	CVW-1	CVA 42	A-4C	SoLant/IO/West Pac/Vietnam
24 Aug 1967	19 May 1968	CVW-1	CVA 42	A-4C	Med

**Major Overseas Deployments—Continued**

<i>Date of Departure</i>	<i>Date of Return</i>	<i>Air Wing</i>	<i>Carrier</i>	<i>Type of Aircraft</i>	<i>Area of Operation</i>
07 Jan 1969	29 Jul 1969	CVW-8	CVA 38	A-4C	Med
05 Mar 1970	17 Dec 1970	CVW-8	CVS 38	A-4C	SoLant/IO/West Pac/Vietnam

\* CVG-82 was redesignated CVAG-17 during the deployment.

† The squadron departed NAS San Diego on 16 July 1951 embarked in *Antietam* (CV 36) and arrived in Hawaii on 20 July. On 21 July it embarked in *Essex* (CV 9) and departed for a combat cruise to Korea on 9 August.

‡ In October 1964 *Franklin D. Roosevelt* (CVA 42) returned to the States for an emergency dry docking to repair a propeller. The squadron was based ashore at NAS Cecil Field during that time frame. Following the repair, the carrier and squadron returned to the Mediterranean.



*A squadron F2H-2 Banshee in flight during its combat deployment to Korea aboard Essex (CV 9), 1951.*

**Air Wing Assignments**

<i>Air Wing</i>	<i>Tail Code</i>	<i>Assignment Date</i>
CVG-82/CVAG-17/ CVG-17*	R†	20 Aug 1945
CVG-5	S	21 Jul 1951
CVG-17	R	25 Mar 1952
COMFAIRJACKSONVILLE		1957‡
CVG-1/CVW-1§	AB	15 Mar 1958
CVW-8	AJ	25 Aug 1968

\* CVG-82 was redesignated CVAG-17 on 15 November 1946. CVAG-17 was redesignated CVG-17 on 1 September 1948.

† The tail code R was assigned to CVAG-17 on 12 December 1946.

‡ The squadron was transferred from CVG-17 and operational control was assigned to COMFAIRJACKSONVILLE some time in early 1957.

§ CVG-1 was redesignated CVW-1 when Carrier Air Groups (CVG) were redesignated Carrier Air Wings (CVW) on 20 December 1963.

**Unit Awards Received**

<i>Unit Award</i>	<i>Inclusive Dates Covering Unit Award</i>	
NUC	21 Aug 1951	05 Mar 1952
KSM	13 Aug 1951	05 Mar 1952
NEM	20 Nov 1961	29 Nov 1961
MUC	11 Apr 1970	06 Nov 1970
RVNGC	21 Oct 1966	
VNSM	30 Jul 1966	
	09 Aug 1966	12 Sep 1966
	01 Oct 1966	03 Oct 1966
	19 Oct 1966	14 Nov 1966

**Unit Awards Received**

<i>Unit Award</i>	<i>Inclusive Dates Covering Unit Award</i>	
	24 Nov 1966	28 Dec 1966
	20 Jan 1967	21 Jan 1967
	10 Apr 1970	02 May 1970
	12 May 1970	29 May 1970
	13 Jun 1970	04 Jul 1970
	28 Jul 1970	19 Aug 1970
	30 Aug 1970	30 Sep 1970
	20 Oct 1970	07 Nov 1970



*A flight of squadron A-4C Skyhawks with tail hooks down preparing for a landing on Shangri-La (CVS 38) during her deployment in 1970.*

## VA-174

### Lineage

Established as Bombing Squadron EIGHTY TWO (VB-82) on 1 April 1944.

Redesignated Attack Squadron SEVENTEEN A (VA-17A) on 15 November 1946.

Redesignated Attack Squadron ONE HUNDRED SEVENTY FOUR (VA-174) on 11 August 1948.

Disestablished on 25 January 1950. The first squadron to be assigned the VA-174 designation.

### Squadron Insignia and Nickname



The squadron's battering ram insignia.

The squadron's insignia was approved by CNO on 21 January 1946. Colors for the insignia were: a dark blue background with a yellow border; the star had alternating shades of yellow and light mustard; the goat and bomb were shaded light gray to dark gray.

Nickname: Battering Rams, 1946–1950.

### Chronology of Significant Events

**15 Dec 1944:** The squadron embarked in *Bennington* (CV 20), along with other units of CVG-82, and departed for Pearl Harbor, arriving there on 7 January 1945, following a stop over at NAS San Diego.

**16 Feb 1945:** VB-82 participated in the first carrier-based air strikes on Tokyo, flying sorties against installations at Mitsune and Mikatagahara Airfields on Hachijo Jima, Nanpo Shoto.

**20–22 Feb 1945:** Squadron aircraft provided air support for the landings on Iwo Jima.

**19 Mar 1945:** Japanese naval vessels in the Inland Sea were attacked by VB-82 aircraft and other aircraft assigned to Task Group 58.1.

**7 Apr 1945:** Squadron aircraft participated in Task Force 58's attacks on the Japanese super battleship *Yamato* and her escorts in the East China Sea. The

attacks resulted in the sinking of the *Yamato*, one cruiser and four destroyers.

**Mar–May 1945:** The squadron participated in preinvasion strikes on Okinawa and provided air support during the invasion of the island.

**17 Jun–9 Jul 1945:** The squadron was embarked in *White Plains* (CVE 66) for transit back to the States.

### Home Port Assignments

Location	Assignment Date
NAS Wildwood	01 Apr 1944*
NAAS Oceana	15 Jun 1944*
NAS Norfolk, East Field	17 Sep 1944*
NAS Quonset Point	13 Nov 1944*
NAS Kahului	08 Jan 1945*
NAS Alameda	09 Jul 1945
NAS Quonset Point	01 Feb 1946
NAAS Cecil Field	01 Feb 1949

\* Temporary shore assignment while the squadron conducted training in preparation for combat deployment.

### Commanding Officers

	Date Assumed Command
LCDR Samuel R. Brown, Jr.	01 Apr 1944
LCDR Hugh Wood, Jr. (acting)	31 Dec 1944
LCDR Hugh Wood, Jr.	11 Jan 1945
LT J. A. Derby (acting)	11 Jul 1945
LT Harry R. McRae, Jr. (acting)	04 Sep 1945
LCDR Hugh Wood, Jr.	13 Oct 1945
LCDR Robert E. Farkas	02 Apr 1948
LCDR William R. Pittman	10 Jun 1949
LCDR Harold E. Vita	14 Dec 1949

### Aircraft Assignment

Type of Aircraft	Date Type First Received
SB2C-1C	01 Apr 1944
SB2C-3	22 May 1944
SB2C-4E	17 Nov 1944
SBW-4E	Feb 1946
SB2C-5	01 Jul 1946
SBW-5	Jul 1946
AM-1	01 Mar 1948
AD-3	Apr 1949

### Major Overseas Deployments

Date of Departure	Date of Return	Air Wing	Carrier	Type of Aircraft	Area of Operation
29 Jan 1945	17 Jun 1945	CVG-82	CV 20	SB2C-4E	Pacific
22 Oct 1946	21 Dec 1946	CVG-82*	CV 15	SB2C-5	Med

\* CVG-82 was redesignated CVAG-17 during the deployment.



**Air Wing Assignments**

<i>Air Wing</i>	<i>Tail Code</i>	<i>Assignment Date</i>
CVG-82//CVAG-17/ CVG-17*	R†	01 Apr 1944

\* CVG-82 was redesignated CVAG-17 on 15 November 1946. CVAG-17 was redesignated CVG-17 on 1 September 1948.

† The tail code R was assigned to CVAG-17 on 12 December 1946.

**Unit Awards Received**

<i>Unit Award</i>	<i>Inclusive Dates Covering Unit Award</i>	
NAVE	01 Jul 1947	30 Jun 1948
Campaign Medal (Asiatic Pacific)	15 Feb 1945	04 Mar 1945
	17 Mar 1945	11 Jun 1945



*A squadron SB2C-4E Helldiver launches from Bennington (CV 20), 1945 (Courtesy Robert Lawson Collection).*

## SECOND VA-174

### Lineage

Established as Bombing Squadron EIGHTY ONE (VB-81) on 1 March 1944.

Redesignated Attack Squadron THIRTEEN A (VA-13A) on 15 November 1946.

Redesignated Attack Squadron ONE HUNDRED THIRTY FOUR (VA-134) on 2 August 1948.

Redesignated Fighter Squadron ONE HUNDRED SEVENTY FOUR (VF-174) on 15 February 1950.

Redesignated Attack Squadron ONE HUNDRED SEVENTY FOUR (VA-174) on 1 July 1966.

Disestablished on 30 June 1988. The second squadron to be assigned the VA-174 designation.



*This Walt Disney design was the squadron's first insignia.*

The squadron's Walt Disney designed insignia was approved by CNO on 23 May 1944. Colors for the bat insignia were: a lemon yellow background; the underside of the bat's wings were reddish brown and the upper side orange; the bat's face, neck, feet and lower part of the razor were orange; the upper part of the razor was light blue with white markings; the bat's eye was white, pupil black and horns white outlined in black; white machine gun with black markings and red flame from the gun; black bombs with white markings and the lettering "Hell Razors" was red. The red color was not authorized for use during World War II. The insignia remained in use throughout the squadron's numerous redesignations.

Nickname: Hell Razors, 1944–1988.

### Squadron Insignia and Nickname

The squadron's Walt Disney designed insignia was approved by CNO on 23 May 1944. Colors for the bat insignia were: a lemon yellow background; the underside of the bat's wings were reddish brown and the upper



*The squadron added the scroll at the bottom of the original insignia following its redesignation to VA-174.*

### Chronology of Significant Events

**23–31 Aug 1944:** The squadron, along with other units of CVG-81, embarked in *Hancock* (CV 19) for transportation to Hawaii.

**28 Oct–7 Nov 1944:** Embarked in *Copabee* (CVE 12)

for transportation to Guam.

**14 Nov 1944:** CVG-81 aircraft engaged in their first combat sorties, flying missions against Luzon from *Wasp* (CV 18).

**27 Dec 1944:** The squadron was detached from CVG-81, embarked in *Wasp* (CV 18), and flew to Guam. This was done to accommodate an increase in the fighter strength aboard the carrier.

**Mar 1945:** VB-81 rejoined CVG-81 aboard *Copabee* for the transit back to the States.

**Aug 1948–Apr 1949:** Even though the squadron's designation was attack (VA) its mission during this period, with the assigned F4U-4 Corsairs, was high altitude intercept.

**Oct 1948–Feb 1949:** VA-134, assigned to CVG-1, embarked in *Tarawa* (CV 40), was part of an all-fighter aircraft air group deployed on a world cruise.

**Jan 1949:** The squadron operated in the Persian Gulf while embarked in *Tarawa*.

**Feb 1955:** While deployed aboard *Midway* (CVA 43), the squadron supported the evacuation of Chinese Nationalist civilians and military personnel from the Tachen Islands which were being bombarded by the People's Republic of China.

**28 Apr 1958:** The squadron's mission was changed to the training of pilots and enlisted men for F8U Crusader fleet squadrons on the east coast.

**10–17 May 1958:** Four squadron Crusaders participated in Operation Pipeline, the transAtlantic flight of carrier jet aircraft for the resupply of deployed squadrons in the Sixth Fleet.

**14 Oct 1966:** VA-174 was the first Navy squadron to receive the A-7A Corsair II aircraft.

**Jan 1967:** VA-86 was the first squadron to undergo training with VA-174 in the A-7A.

**9 Dec 1976:** Lieutenant Junior Grade Rosemary Conatser, while undergoing pilot training with VA-174, became the first woman to fly the A-7 Corsair II.



*A squadron SB2C-3 Helldiver coming in for a landing, 1945 (Courtesy Robert Lawson Collection).*

**Home Port Assignments**

<i>Location</i>	<i>Assignment Date</i>
NAS Wildwood	01 Mar 1944*
NAAF Otis Field	08 May 1944*
NAS San Diego	10 Aug 1944*
NAS Puunene	01 Sep 1944*
NAS Guam	27 Dec 1944
NAS San Diego	31 Mar 1945
NAS Pasco	13 May 1945
NAS Wildwood	05 Aug 1945
NAS Quonset Point	19 Sep 1945
NAS San Diego	Jul 1946
NAS Sand Point	28 Jun 1947
NAS San Diego	02 Sep 1947
NAS Jacksonville	11 Apr 1949
NAS Cecil Field	Apr 1954

\* Temporary shore assignment while the squadron conducted training in preparation for combat deployment.

**Commanding Officers**

	<i>Date Assumed Command</i>
CDR Jerry L. Terrell	16 May 1975
CDR John S. McCain III	01 Jul 1976
CDR John F. Calhoun	28 Jul 1977
CDR John D. Rasmussen	26 Oct 1978
CDR Robert J. Naughton	17 Jan 1980
CDR Robert S. Smith	12 Mar 1981
CAPT D. B. Hunt	Jul 1982
CAPT Robert L. Kiem	31 Aug 1983
CDR Michael B. Nordeen	06 Sep 1984
CDR Charles A. Cook	06 Sep 1985
CDR E. Evan Shipe III	29 Apr 1986
CDR Dean M. Hendrickson	16 Apr 1987

\* Commander H. P. Lanham was detached as Commanding Officer of VB-81 and assigned as Commanding Officer of VF-81. There is no record of who assumed the position as acting commanding officer of VB-81 while it was shore based at Guam.

**Commanding Officers**

	<i>Date Assumed Command</i>
LCDR Harvey P. Lanham	01 Mar 1944
	Feb 1945*
LT Hugh Burns (acting)	13 May 1945
LT Hugh Burns	04 Jun 1945
LTJG W. D. Page (acting)	09 Sep 1945
LCDR William E. Rouse	21 Sep 1945
LT Loren E. Nelson (acting)	07 Nov 1946
LCDR Gene C. Anderson	13 Jan 1947
LT Martin G. O'Neill (acting)	06 Jun 1948
LCDR S. C. Walls	06 Jul 1948
CDR John C. Kelly	20 Jun 1949
LCDR Ralph E. Elliott, Jr.	25 May 1950
LCDR Paul B. Garrison	14 Aug 1951
LCDR John H. Iarrobino	20 Jun 1952
CDR George H. Sult	Mar 1953
CDR J. C. Schroeder	Sep 1955
LCDR John F. Davis	Aug 1957
CDR W. S. Miller	09 Jan 1959
CDR R. T. Hoppe	01 Jul 1960
CDR Carl C. Dace	09 Jun 1961
CDR Edward Iglesias	Feb 1962
CDR Homer A. Winter	Jul 1963
CDR Wiley A. Scott	28 Aug 1964
CDR G. L. Gray, Jr.	11 Aug 1965
CDR Donald S. Ross	12 Aug 1966
CDR William F. Sallada	16 Jun 1967
CDR Edwin M. Crow	09 Aug 1968
CDR J. E. Russ	03 Jul 1969
CDR Roger C. Bos	04 Sep 1970
CDR John J. Lahr	06 Aug 1971
CDR Rolland K. Shea	07 Jul 1972
CDR Michael G. Basford	01 Jun 1973
CDR Donald B. Gilbert	27 Jun 1974



A squadron F4U-4 Corsair launching from the deck of Tarawa (CV 40) during her world cruise in 1948-1949.

**Aircraft Assignment**

<i>Type of Aircraft</i>	<i>Date Type First Received</i>
SB2C-3	Mar 1944
SB2C-1C	Mar 1944
SB2C-4E	May 1945
SB2C-5	Dec 1945
SBW-5	Jan 1946
F4U-4	04 Mar 1948
F4U-5	Jun 1950
F9F-6	Jan 1953
FJ-3	Sep 1955
F9F-8	Mar 1956
F8U-1/F-8A*	30 Oct 1957
TV-2	17 Sep 1958
F9F-8T	08 Jul 1959
F8U-1P/RF-8A*	Oct 1959
F8U-2/F-8C*	Oct 1959
F8U-1E/F-8B*	Jul 1959

### Aircraft Assignment

Type of Aircraft	Date Type First Received
F8U-2N/F-8D*	Nov 1960
F8U-2NE/F-8E*	Apr 1962
A-7A	14 Oct 1966
A-7B	09 Jul 1968
A-7E	18 Dec 1969
T-39D	1975
TA-7C	09 Jun 1978

\* The F8U Crusader designations were changed in 1962 to F-8.



A flight of squadron F9F-8 Cougars during their deployment aboard Bennington (CVA 20) in 1956–1957.

### Major Overseas Deployments

Date of Departure	Date of Return	Air Wing	Carrier	Type of Aircraft	Area of Operation
10 Nov 1944	27 Dec 1944	CVG-81	CV 18	SB2C-3	Pacific
03 Jul 1946	15 Apr 1947	CVG-81*	CV 37	SB2C-5/SBW-5	WestPac
01 Oct 1948	21 Feb 1949	CVG-1	CV 40	F4U-4	World Cruise
09 Sep 1950	01 Feb 1951	CVG-17	CVB 43	F4U-5	Med
03 Sep 1952	18 Dec 1952	CVG-17	CVA 42	F4U-4	NorLant/Med
27 Dec 1954	14 Jul 1955	CVG-1	CVA 41	F9F-6	World Cruise
15 Oct 1956	22 May 1957	ATG-181	CVA 20	F9F-8	WestPac

\* During the deployment CVG-81 was redesignated CVAG-13.

### Air Wing Assignments

Air Wing	Tail Code	Assignment Date
CVG-81/CVAG-13/ CVG-13*	P†	01 Mar 1944
CVG-1	T	22 Sep 1948
CVG-13	P	25 Feb 1949
COMFAIRJACKSONVILLE		30 Nov 1949
CVG-17	R	14 Feb 1950
CVG-1	T	Apr 1954
ATG-181	I	Oct 1956
COMFAIRJACKSONVILLE		May 1957‡
CVG-1	AB	01 Nov 1957
RCVG-4/RCVW-4§	AD	16 Mar 1958
COMLATWING-1	AD**	01 Jun 1970

\* CVG-81 was redesignated CVAG-13 on 15 November 1946 and then redesignated CVG-13 on 1 September 1948.

† The tail code P was assigned to CVAG-13 on 12 December 1946.

‡ The squadron left ATG-181 upon its return from the WestPac deployment in May 1957. VF-174 probably remained under Commander Fleet Air Jacksonville until its assignment to CVG-1. However, no records are available to confirm this supposition.

§ RCVG-4 was redesignated RCVW-4 when Carrier Air Groups (CVG/RCVG) were redesignated Carrier Air Wings (CVW/RCVW) on 20 December 1963.

\*\* RCVW-4 was disestablished on 1 June 1970. However, the squadrons that had been assigned to RCVW-4, such as VA-174, continued to use RCVW-4's AD tail code.

A squadron F-8E Crusader at MCAAS Yuma, 1963 (Courtesy William Swisher Collection).



**Unit Awards Received**

<i>Unit Award</i>	<i>Inclusive Dates Covering Unit Award</i>	
Campaign Medal (Asiatic Pacific)	12 Dec 1944	27 Dec 1944
NUC	14 Nov 1944	19 Nov 1944
	14 Dec 1944	16 Dec 1944
	01 Jul 1950	30 Jun 1951

**Unit Awards Received—Continued**

<i>Unit Award</i>	<i>Inclusive Dates Covering Unit Award</i>	
	01 Jul 1953	30 Jun 1954
MUC	10 Jun 1976	26 Apr 1977
	05 Feb 1979	03 Sep 1980
	01 Jan 1984	01 Apr 1985
	01 Apr 1985	31 Dec 1986



*A squadron A-7 Corsair II loaded with weapons.*

## VA-175

### Lineage

Established as Torpedo Squadron EIGHTY TWO (VT-82) on 1 April 1944.

Redesignated Attack Squadron EIGHTEEN A (VA-18A) on 15 November 1946.

Redesignated Attack Squadron ONE HUNDRED SEVENTY FIVE (VA-175) on 11 August 1948.

Disestablished on 15 March 1958. The first squadron to be assigned the VA-175 designation.

### Squadron Insignia and Nickname



*The first squadron insignia was the devil design.*

The squadron's first insignia was approved by CNO on 4 December 1945. Colors for the devil insignia were: a hyacinth blue background; a white hypodermic needle with a black tip; the devil was red with yellow eyes and black pupils; yellow horns and teeth; and black wings with white ribs.

A new insignia was approved by CNO on 18 October 1951. Colors for the winged figure were: a black background with a yellow border; red winged figure with black markings, white skull with black markings and the wings were black with red markings; white cloud with black markings; yellow bomb with black markings and a green nose; green rocket with black markings, a red nose and yellow and red flames coming from the tail.

Nickname: Devil's Diplomats, time frame unknown.



*During Korea the winged skull man was approved for use by the squadron.*

### Chronology of Significant Events

**15 Dec 1944–7 Jan 1945:** The squadron, embarked in *Bennington* (CV 20), was in transit from Norfolk to Hawaii, with a two day stop over at San Diego.

**7 Jan 1945:** The squadron's commanding officer, Lieutenant Commander W. F. Eadie, was killed in an automobile accident.

**16 Feb 1945:** The squadron participated in its first combat operations, flying sorties against the air strip at Hachijo Jima and against airfields in the Tokyo area. The squadron's commanding officer, Lieutenant Commander E. D. DeGarmo, was awarded the Silver Star for his actions during the missions against the Japanese airfields.

**20–22 Feb 1945:** The squadron provided close air support for operations on Iwo Jima.

**19 Mar 1945:** Squadron aircraft participated in strikes against the Japanese Fleet, which included the battleship *Yamato*, located near Kure and Hiroshima in the Inland Sea.

**7 Apr 1945:** Squadron aircraft were the first to attack a powerful Japanese Task Force that had sortied from the Inland Sea and were operating west of Kyushu. This force included the battleship *Yamato* and her escorts. The squadron achieved hits on two destroyers and one light cruiser, sinking one of the destroyers. Attacks from other task force aircraft resulted in the sinking of the *Yamato*, a cruiser and three other destroyers. Seven squadron pilots were awarded the Navy Cross for their actions during this engagement. They were: Lieutenant Commander Edward E. DeGarmo; Lieutenants Jesse W. Naul, Jr. and Norman A. Wiese; and Lieutenant (jg)s John F. Gilbreath, Jr., Wilfred O. McDowell, Donald B. Barber and Charles R. Walton.

**Mar–May 1945:** The squadron was involved in preinvasion strikes on Okinawa and provided support following the invasion of the island.

**17 Jun 1945:** VT-82 completed its tour of combat duty and embarked in *White Plains* (CVE 66) for its transit back to the States, arriving at NAS Alameda on 9 July.

**Nov–Dec 1956:** *Franklin D. Roosevelt* (CVA 42), with VA-175 embarked, was ordered to deploy and operate off the coast of Spain as a result of the Suez Canal crisis.



*A squadron flak-damaged TBM-3 Avenger returning from a combat mission in February 1945.*

### Home Port Assignments

<i>Location</i>	<i>Assignment Date</i>
NAS Quonset Point	01 Apr 1944
NAAF New Bedford	13 Apr 1944*
NAAS Oceana	16 Jun 1944*
NAS Quonset Point	13 Nov 1944*
NAS Kahului	08 Jan 1945*
NAS Alameda	Jul 1945
NAF Newport	Mar 1946
NAS Quonset Point	Apr 1946
NAAS Cecil Field	11 Jan 1949
NAS Jacksonville	09 Jan 1950

\* Temporary shore assignment while the squadron conducted training in preparation for combat deployment.

### Commanding Officers

	<i>Date Assumed Command</i>
LCDR William F. Eadie	01 Apr 1944
LCDR Edward E. DeGarmo	09 Jan 1945
LT Norman A. Wiese (acting)	03 Jun 1945
LCDR William I. McGowan	Aug 1945
LCDR Guiseppi Macri	11 Feb 1948
LCDR John E. Kennedy	15 Jul 1949

### Commanding Officers

	<i>Date Assumed Command</i>
LCDR Malcolm E. Wolfe	19 Mar 1951
LCDR Ross A. Knight	29 May 1952
LCDR P. P. Hambsch (acting)	01 Aug 1953
CDR M. J. Hanley	Aug 1953
LCDR J. M. Nifong	10 Oct 1953
CDR W. L. Nyburg	Oct 1954
CDR E. F. Gallagher	28 Oct 1955
CDR E. H. Potter, Jr.	Dec 1955

### Aircraft Assignment

<i>Type of Aircraft</i>	<i>Date Type First Received</i>
TMF-1/TBM-1	Apr 1944
TBM-1C	Apr 1944
TBM-3	06 Aug 1944
TBM-3E	Sep 1945
TBM-3Q	May 1946
TBM-3J	Mar 1947
AD-3	16 Feb 1949
AD-4	04 Apr 1950
AD-4L	Feb 1951
AD-4B	Feb 1953
AD-6	Aug 1954

### Major Overseas Deployments

<i>Date of Departure</i>	<i>Date of Return</i>	<i>Air Wing</i>	<i>Carrier</i>	<i>Type of Aircraft</i>	<i>Area of Operation</i>
29 Jan 1945	17 Jun 1945	CVG-82	CV 20	TBM-3	Pacific
22 Oct 1946	21 Dec 1946	CVAG-17	CV 15	TBM-3E/Q	Med
20 May 1947	11 Aug 1947	CVAG-17	CV 15	TBM-3E/Q/J	NorLant/Carib
07 Jun 1948	06 Aug 1948	CVG-17	CVB 43	TBM-3E/Q/J	Med/Carib
09 Sep 1950	01 Feb 1951	CVG-17	CVB 43	AD-4	Med
03 Sep 1951	04 Feb 1952	CVG-17	CVB 42	AD-4/4L	Med
26 Aug 1952	19 Dec 1952	CVG-17	CVB 42	AD-4/4L	NorLant/Med
16 Sep 1953	01 May 1954	CVG-17	CVA 18	AD-4/B/L	World Cruise
05 Apr 1955	29 Sep 1955	CVG-17	CVA 43	AD-6	Med
12 Jul 1957	05 Mar 1958	CVG-17	CVA 42	AD-6	Med



*A flight of squadron TBM-3E Avengers in July 1948 (Courtesy Duane Kasulka Collection).*

**Air Wing Assignments**

<i>Air Wing</i>	<i>Tail Code</i>	<i>Assignment Date</i>
CVG-82/CVAG-17/ CVG-17*	R†/AL‡	01 Apr 1944

\* CVG-82 was redesignated CVAG-17 on 15 November 1946 and then redesignated CVG-17 on 1 September 1948.

† The tail code R was assigned to CVAG-17 on 12 December 1946.

‡ The tail code was changed from R to AL in 1957. The effective date for this change was most likely the beginning of FY 58 (1 July 1957).

**Unit Awards Received**

<i>Unit Award</i>	<i>Inclusive Dates Covering Unit Award</i>	
NAVE	01 Jul 1948	30 Jun 1949
Campaign Medal (Asiatic Pacific)	15 Feb 1945	04 Mar 1945
	17 Mar 1945	11 Jun 1945



*A squadron AD-3 or 4 Skyraider, circa 1948 or 1949. Notice the Battle E on the fuselage (Courtesy Duane Kasulka Collection).*



## VA-176

### Lineage

Established as Attack Squadron ONE HUNDRED SEVENTY SIX (VA-176) on 1 June 1955.

Disestablished 30 October 1992. The first squadron to be assigned the VA-176 designation.



The torch design was the squadron's first insignia.

the inner one was light blue; white mailed fist with black markings; yellow torch with black markings and a bright red flame; white atomic clouds with blue borders and markings. The scroll had a white background outlined in dark blue with dark blue lettering.



The squadron's second insignia adopted the mailed fist.

### Squadron Insignia and Nickname

The squadron's first insignia was approved by CNO on 16 July 1956. Colors for torch insignia were: a light blue background outlined in dark blue; the shield was outlined in white with white stars on a dark blue field; the outer thunderbolt was international orange and

The squadron's second insignia was approved by CNO on 3 January 1974. Colors for this insignia were: a dark blue background and scroll outlined in black and white; white stars and lettering; blue mailed fist is outlined in white; and an orange lightning bolt.

Nickname: Thunderbolts, 1955–1992.

### Chronology of Significant Events

**Oct–Dec 1956:** *Randolph* (CVA 15), with VA-176 embarked, was ordered to operate off the coast of Egypt in response to the Suez War.

**14 Nov–8 Dec 1960:** Following a request from Guatemala and Nicaragua, a Navy patrol was established off the coast of these Central American countries to prevent infiltration by communists from Cuba. The squadron operated from *Shangri-La* (CVA 38) until 25 November when it conducted a complete transfer of aircraft and personnel from *Shangri-La* to *Wasp* (CVA 18) while underway. It remained on station aboard *Wasp* until 8 December.

**2–19 Jun 1961:** Following the assassination of the Dominican Republic's dictator, General Rafael Trujillo, the squadron operated from *Shangri-La* off the coast of that country until the domestic situation began to stabilize.

**May 1963:** The squadron operated from *Shangri-La* in the Caribbean during the period of unrest in Haiti and the civil strife with the Dominican Republic.

**Aug 1965:** Squadron aircraft were used in Operation Pinwheel on several occasions while *Shangri-La* was moored at Naples, Italy. The aircraft were secured to the deck of the carrier and the thrust from their propellers were used to help prevent the ship, which was undergoing repairs, from breaking out of her mooring during bad weather and high winds.

**4 Apr 1966:** VA-176 deployed to Vietnam as a component of CVW-10 embarked in *Intrepid* (CVS 11). This was the first all attack air wing formed and the first to deploy. Two squadrons were flying the A-1 Skyraider and two the A-4 Skyhawk.

**15 May 1966:** Flying from Dixie Station, the squadron conducted its first combat sorties, flying strikes against insurgent forces in the Republic of Vietnam.

**9 Oct 1966:** While flying a rescue combat air patrol mission, four squadron aircraft engaged four North Vietnamese MiGs. Lieutenant (jg) William T. Patton shot down one of the MiG-17s during the engagement. This was the first and only shoot down of an enemy jet aircraft by a propeller driven plane during the Vietnam Conflict. For this action, Lieutenant (jg) Patton was awarded the Silver Star.

**8 Jun 1967:** When Israeli forces attacked *Liberty* (AGTR 5), four squadron aircraft were launched from *Saratoga* (CVA 60) and ordered to proceed to the ship and defend it. Shortly after their launch the aircraft were recalled when Israel apologized for the attack.

**Aug 1969:** Squadron A-6A Intruders were used in operation Storm Fury 1969. The aircraft were used to seed Hurricane Debbie by flying sorties that penetrated the wall of the hurricane, flew through the eye and exited the wall again, at which time seeding chemicals were dispensed.

**25 Sep 1970:** VA-176 became the first fleet squadron to operate the KA-6D tanker aircraft.

**Oct–Nov 1973:** The squadron, embarked in *Franklin D. Roosevelt* (CVA 42), operated in the vicinity of Crete in response to the Arab-Israeli war.

**Jun 1976:** The American Ambassador to Lebanon was assassinated on 13 June and *America* (CV 66), with VA-176 embarked, operated in the vicinity of Lebanon. Squadron aircraft flew support missions during the evacuation of noncombatants from that country.

**May 1981:** *Independence* (CV 62), with VA-176 embarked, following its transit of the Suez Canal, remained on station in the eastern Mediterranean due to the crisis between Israel and Syria following Israeli

raids against Syrian surface-to-air missile sites in Lebanon.

**25 Oct–1 Nov 1983:** In response to continued political strife and the need to protect and evacuate Americans from the island country of Granada, VA-176 aircraft flew combat close air support and reconnaissance sorties in support of operation Urgent Fury, the landing of U.S. Marines and Army rangers on the island.

**4 Dec 1983:** In response to hostile fire against U.S. reconnaissance aircraft from Syrian positions in Lebanon, VA-176 aircraft participated in a coordinated

strike against Syrian radar, communications and artillery positions overlooking the Multi-National Peacekeeping Forces. All five of the squadron aircraft completed their mission and returned safely to the carrier.

**Jun–Jul 1988:** The squadron flew support for Earnest Will Missions, escort operations for reflagged Kuwaiti oil tankers during the Iraq-Iranian War in the Persian Gulf.

**Jun–Sep 1991:** The squadron flew missions in support of Operation Provide Comfort, supporting the 24th Marine Expeditionary Unit's mission to aid the Kurdish refugees in Iraq following the Gulf War.



*A squadron A-1H Skyraider launching from the deck of Intrepid (CVS 11) during their combat deployment to Vietnam in 1966. Note the sortie mission marks and the aircraft symbol for a MiG shoot down on the fuselage just below the canopy.*

### Home Port Assignments

<i>Location</i>	<i>Assignment Date</i>
NAS Cecil Field	01 Jun 1955
NAS Jacksonville	Feb 1955
NAS Oceana	May 1968

### Commanding Officers

	<i>Date Assumed Command</i>
CDR James M. O'Brien	01 Jun 1955
CDR L. W. S. Cummins	10 Apr 1957
CDR D. C. Standley	17 Mar 1958
CDR U. W. Patrick	27 Feb 1959
CDR Robert J. Stegg	30 Mar 1960

### Commanding Officers

	<i>Date Assumed Command</i>
CDR B. B. Forbes, Jr.	11 Sep 1961
CDR H. P. Maulden	1962
CDR R. Brooke	27 Sep 1963
CDR George D. Edwards, Jr.	09 Oct 1964
CDR Robert J. Martin	08 Oct 1965
CDR A. R. Ashworth	27 Sep 1966
CDR J. T. French	01 Aug 1967
CDR Charles L. Cook	25 Apr 1968
CDR John B. Davis	30 Aug 1969
CDR Howard W. Alexander	11 Aug 1970
CDR Samson Mikitarian	24 Aug 1971
CDR Richard M. Dunleavy	31 Jul 1972

### Commanding Officers

	<i>Date Assumed Command</i>
CDR John H. McKenzie	18 Jun 1973
CDR Raymond P. Ilg	27 Jun 1974
CDR Robert H. Ferguson	10 Oct 1975
CDR Marshall A. Howard	06 Feb 1977
CDR Manuel Oretaga	23 Mar 1978
CDR Frank L. Stauts	15 Jun 1979
CDR Douglas K. Griffith	02 Sep 1980
CDR Timothy R. Beard	19 Nov 1981
CDR Michael P. Currie	11 Feb 1983
CDR James E. Hurston	26 Jul 1984
CDR Gary W. Stubbs	23 Jan 1986
CDR Ross A. Word	04 Jun 1987
CDR Frank W. Montesano	08 Dec 1988
CDR William G. Ballard	01 Jun 1990
CDR Lee A. Hawks	31 Jul 1991

### Aircraft Assignment

<i>Type of Aircraft</i>	<i>Date Type First Received</i>
AD-6/A-1H*	Jun 1955
A-6A	05 Feb 1969
KA-6D	25 Sep 1970
A-6C	1971
A-6E	Jul 1975

\* The AD-6 designation was changed to A-1H in 1962.



*Lieutenant (jg) William T. Patton standing alongside the A-1H Skyraider that he was flying when he shot down a North Vietnamese MiG-17 on 9 October 1966.*

### Major Overseas Deployments

<i>Date of Departure</i>	<i>Date of Return</i>	<i>Air Wing</i>	<i>Carrier</i>	<i>Type of Aircraft</i>	<i>Area of Operation</i>
14 Jul 1956	19 Feb 1957	ATG-202	CVA 15	AD-6	Med
07 Aug 1959	26 Feb 1960	CVG-10	CVA 9	AD-6	Med
06 Sep 1960	20 Oct 1960	CVG-10	CVA 38	AD-6	NorLant
02 Feb 1961	15 May 1961	CVG-10	CVA 38	AD-6	Med
07 Feb 1962	28 Aug 1962	CVG-10	CVA 38	AD-6	Med
01 Oct 1963	23 May 1964	CVW-10	CVA 38	A-1H	Med
15 Feb 1965	20 Sep 1965	CVW-10	CVA 38	A-1H	Med
04 Apr 1966	21 Nov 1966	CVW-10	CVS 11	A-1H	Med/IO/West Pac/Vietnam
02 May 1967	06 Dec 1967	CVW-3	CVA 60	A-1H	Med
02 Jan 1970	27 Jul 1970	CVW-6	CVA 42	A-6A	Med
29 Jan 1971	23 Jul 1971	CVW-6	CVA 42	A-6A & KA-6D	Med
15 Feb 1972	08 Dec 1972	CVW-6	CVA 42	A-6A/C & KA-6D	Med
14 Sep 1973	17 Mar 1974	CVW-6	CVA 42	A-6A/C & KA-6D	Med
03 Jan 1975	16 Jul 1975	CVW-6	CV 42	A-6A/C & KA-6D	Med
15 Apr 1976	25 Oct 1976	CVW-6	CV 66	A-6E & KA-6D	Med
10 Jun 1977	19 Jul 1977	CVW-6	CV 66	A-6E & KA-6D	SoLant
29 Sep 1977	25 Apr 1978	CVW-6	CV 66	A-6E & KA-6D	Med
28 Jun 1979	14 Dec 1979	CVW-6	CV 62	A-6E & KA-6D	Med
19 Nov 1980	10 Jun 1981	CVW-6	CV 62	A-6E & KA-6D	SoLant/IO/Med
07 Jun 1982	22 Dec 1982	CVW-6	CV 62	A-6E & KA-6D	Med
18 Oct 1983	11 Apr 1984	CVW-6	CV 62	A-6E & KA-6D	Carib/Med/ NorLant

**Major Overseas Deployments—Continued**

<i>Date of Departure</i>	<i>Date of Return</i>	<i>Air Wing</i>	<i>Carrier</i>	<i>Type of Aircraft</i>	<i>Area of Operation</i>
16 Oct 1984	19 Feb 1985	CVW-6	CV 62	A-6E & KA-6D	Med/IO
02 Jun 1986	10 Nov 1986	CVW-6	CV 59	A-6E & KA-6D	Med
28 Aug 1987	08 Oct 1987	CVW-6	CV 59	A-6E & KA-6D	NorLant
25 Apr 1988	07 Oct 1988	CVW-6	CV 59	A-6E & KA-6D	Med/IO/NorLant
03 Nov 1989	12 Apr 1990	CVW-6	CV 59	A-6E & KA-6D	Med
30 May 1991	21 Dec 1991	CVW-6	CV 59	A-6E & KA-6D	Med

**Air Wing Assignments**

<i>Air Wing</i>	<i>Tail Code</i>	<i>Assignment Date</i>
ATG-202	X*/AQ†	01 Jun 1955
CVG-17	AL	15 Mar 1958
COMFAIRJACKSON-VILLE		13 Sep 1958
CVG-10/CVW-10‡	AK	16 Apr 1959
CVW-3	AC	01 Mar 1967
COMFAIRJACKSON-VILLE		06 Dec 1967§
COMFAIRNORFOLK		May 1968
CVW-6	AE	01 Apr 1969

\* The tail code X was not assigned to ATG-202 until 1956.

† The tail code was changed from X to AQ in 1957. The effective date for this change was most likely the beginning of FY 58 (1 July 1957).

‡ CVG-10 was redesignated CVW-10 when Carrier Air Groups (CVG) were redesignated Carrier Air Wings (CVW) on 20 December 1963.

§ VA-176 was transferred from CVW-3 when it returned from its Med deployment on 6 December 1967. It is believed the squadron came under the control of Commander Fleet Air Jacksonville until its transfer to Commander Fleet Air Norfolk, when it began transition training for the A-6 Intruder.

**Unit Awards Received**

<i>Unit Award</i>	<i>Inclusive Dates Covering Unit Award</i>		
NAVE	01 Jul 1962	30 Jun 1963	
	01 Jul 1964	30 Jun 1965	
	01 Jul 1974	30 Jun 1975	
	01 Jan 1988	31 Dec 1988	
	01 Jan 1989	31 Dec 1989	
	01 Jan 1990	31 Dec 1990	
	NEM	07 Dec 1980	11 May 1981
		20 Aug 1982	05 Sep 1982
		01 Oct 1982	06 Dec 1982
		16 Nov 1983	30 Nov 1983
24 Oct 1983		02 Nov 1983	
16 Nov 1983		22 Dec 1983	
28 Dec 1983		03 Jan 1984	
15 Jan 1984		03 Feb 1984	
09 Feb 1984		02 Mar 1984	
20 Jun 1976		27 Jul 1976	
HSM	09 Mar 1972	01 Dec 1972	
	01 May 1987	08 Oct 1988	
	MUC	20 Oct 1983	03 Mar 1984
		Jun 1991	Sep 1991
		05 May 1966	06 May 1966
		14 May 1966	17 Jun 1966
		08 Jul 1966	10 Aug 1966
		01 Sep 1966	23 Sep 1966
		02 Oct 1966	18 Oct 1966
		VNSM	01 May 1966
01 May 1966			01 Oct 1966
RVNGC			



*A squadron A-6E Intruder in flight, 1976.*

## VA-185

### Lineage

Established as Attack Squadron ONE HUNDRED EIGHTY FIVE (VA-185) on 1 December 1986

Disestablished on 30 August 1991. The first squadron to be assigned the VA-185 designation.

### Squadron Insignia and Nickname

The squadron's insignia was approved by CNO on 8 September 1986. Colors for the hawk insignia were: a black background; a blue sea and white sky with black markings; white hawk with black markings, red eyes and claws; gold star; blue upper scroll outlined in black with gold lettering; gold lower scroll outlined in black with blue lettering.



The squadron's Nighthawks insignia.

Nickname: Nighthawks, 1986–1991.

### Chronology of Significant Events

Sep 1987: The squadron was forward deployed to NAS Atsugi, Japan, and assigned to *Midway* (CV 41), home ported at Naval Station Yokosuka, Japan.

Nov 1987-Jan 1988: The squadron flew support for Earnest Will Missions, escort operations for reflagged Kuwaiti oil tankers during the Iraq-Iranian War in the Persian Gulf.

Sep 1988: VA-185, embarked in *Midway*, operated in the Sea of Japan during the summer Olympics being held in Seoul, Korea, to demonstrate U.S. support for a peaceful olympics.

Dec 1989: *Midway*, with VA-185 embarked, maintained station off the coast of Philippines during an attempted coup in that country.

Nov 1990-Jan 1991: The squadron flew missions in support of Operation Desert Shield, the build-up of American and Allied forces to counter a threatened invasion of Saudi Arabia by Iraq and were part of an economic blockade of Iraq to force its withdrawal from Kuwait.

Jan-Feb 1991: The squadron participated in Operation Desert Storm. VA-185 led the first air strikes from naval elements operating in the Persian Gulf. During the Gulf War, squadron aircraft struck Iraqi naval targets and bases, airfields and bridges, and provided close air support for Allied ground forces. The squadron flew a total of 457 combat missions, comprising 940 combat flight hours and delivered 720,000 pounds of ordnance on enemy targets.

6 Aug 1991: The squadron held a disestablishment ceremony at NAF Atsugi, Japan. It was officially disestablished on 30 August 1991.

### Home Port Assignments

Location	Assignment Date
NAS Whidbey Island	01 Dec 1986
NAF Atsugi, Japan*	13 Sep 1987

\* VA-185 was forward deployed and based aboard *Midway* (CV 41).

### Commanding Officers

	Date Assumed Command
CDR William J. Magnan	01 Dec 1986
CDR Michael J. McCamish	18 Nov 1988
CDR Bernard M. Satterwhite, Jr.	01 Jun 1990

### Aircraft Assignment

Type of Aircraft	Date Type First Received
A-6E	18 Feb 1987
KA-6D	19 Sep 1987

### Major Overseas Deployments

Date of Departure	Date of Return	Air Wing	Carrier	Type of Aircraft	Area of Operation
15 Oct 1987	12 Apr 1988	CVW-5	CV 41	A-6E & KA-6D	WestPac/IO
18 Oct 1988	09 Nov 1988	CVW-5	CV 41	A-6E & KA-6D	WestPac
21 Jan 1989	24 Feb 1989	CVW-5	CV 41	A-6E & KA-6D	WestPac
27 Feb 1989	09 Apr 1989	CVW-5	CV 41	A-6E & KA-6D	WestPac
31 May 1989	25 Jul 1989	CVW-5	CV 41	A-6E & KA-6D	WestPac
15 Aug 1989	11 Dec 1989	CVW-5	CV 41	A-6E & KA-6D	WestPac/IO
25 Jan 1990	06 Apr 1990	CVW-5	CV 41	A-6E & KA-6D	WestPac
02 Oct 1990	17 Apr 1991	CVW-5	CV 41	A-6E & KA-6D	WestPac/IO/ Persian Gulf

Note: Deployments will cover only those operations which take the carrier outside the home waters of Japan. It does not include squadron shore-based operations in Korea or the Philippines.

**Air Wing Assignments**

<i>Air Wing</i>	<i>Tail Code</i>	<i>Assignment Date</i>
COMMATVAQ- WINGPAC		01 Dec 1986
CVW-5	NF	13 Sep 1987

**Unit Awards Received**

<i>Unit Award</i>	<i>Inclusive Dates Covering Unit Award</i>	
MUC	01 Dec 1986	15 Oct 1987
	15 Oct 1989	29 Oct 1989
KLM	17 Jan 1991	28 Feb 1991
SASM	02 Nov 1990	14 Mar 1991
NAVE	01 Jan 1989	31 Dec 1989
	01 Jan 1990	31 Dec 1990
NUC	17 Jan 1991	07 Feb 1991



*A flight of squadron A-6E Intruders, July 1987 (Courtesy Robert Lawson).*

## VA-194

### Lineage

Established as Bombing Squadron NINETEEN (VB-19) on 15 August 1943.

Redesignated Attack Squadron NINETEEN A (VA-19A) on 15 November 1946.

Redesignated Attack Squadron ONE HUNDRED NINTY FOUR (VA-194) on 24 August 1948.

Disestablished on 1 December 1949. The first squadron to be assigned the VA-194 designation.

### Squadron Insignia and Nickname

The squadron's first insignia was approved by CNO on 26 May 1944. Colors for the winged lion rampant and bomb were: yellow shield outlined in black; black bomb; and a green winged lion rampant with black markings on the wings and a red eye and tongue.



*The rampant winged lion was the squadron's first insignia.*

black markings, its wings were chartreuse with a white star on a circular blue background; yellow rockets and chartreuse machine guns with black markings; white bulldogs with orange collars; the bulldog in front had a black face with yellow eyes, black pupils, and an orange snout, tongue and lips and white teeth.

A new squadron insignia was approved by

A new insignia was approved by CNO on 9 July 1945. Colors for this insignia were: a medium blue background; a yellow flying bomb with



*The dogs riding a winged bomb was the second insignia used by the squadron.*



*This insignia was tentatively approved for the squadron. However, the squadron was disestablished three months afterwards and it most likely was not implemented for use by the squadron.*

CNO on 11 March 1948 pending the removal of the squadron designation. Colors for the winged lightning bolt were: a blue background with a white inner border ringed by a yellow rope; maroon lightning bolt; and the wings were yellow with black markings.

Nickname: unknown.

### Chronology of Significant Events

**18–21 Jul 1944:** The squadron's first combat sorties involved preinvasion strikes on Guam. It also provided support for the initial landings on the island.

**Jul–Oct 1944:** Squadron aircraft flew sorties against targets on Palau, Bonin Islands, the Philippines, including Mindanao and Luzon, Okinawa, Formosa and the Pescadores.

**24 Oct 1944:** Squadron aircraft participated in several major engagements during the Battle for Leyte Gulf. VB-19 aircraft flew search missions from north of Lingayen Gulf to the northern tip of Mindoro to locate the Japanese Task Force. It struck the Japanese Central Force in the Sibuyan Sea, which included the super battleship *Musashi*. However, only limited damage was caused by the squadron's attack since its aircraft were armed only with general purpose bombs instead of armor piercing bombs. For his actions during this engagement Lieutenant Leonard R. Swanson was awarded the Navy Cross and Lieutenant (jg)s Stuart E. Crapser and Herbert N. Walters were awarded Silver Stars.

**24 Oct 1944:** The squadron's commanding officer, Commander R. S. McGowan, failed to return from a combat mission and was declared missing in action.

**25 Oct 1944:** The squadron participated in coordinated attacks against the Japanese Carrier Task Force in the Battle Off Cape Engano. VB-19 aircraft claimed they either sunk or assisted in the sinking of three Japanese carriers. Four Japanese carriers were sunk during the battle. Thirty-two squadron pilots were awarded the Navy Cross for their actions in this battle. They were: Lieutenants Price R. Stradley, Robert D. Niemeyer, John B. Gunter, William E. McBride, Emil B. Stella, Jack Meeker, John L. Butts, Jr., Donald F. Helm, Norman E. Thurmon, Donald F. Banker, Robert B. Parker, Joe W. Williams, Jr., William A. Wright and Raymond G. Wicklander; Lieutenant (jg)s George H. Bowen, Melvin L. Chapman, Robert E. Lee Duncan, Jr., Donald D. Engen, Arnost Jancar, Jerry B. Wilton, Webster P. Wodell, Daniel Sadler, Jr., Louis A. Heilmann, George W. Peck, Jack Scott, Stuart E. Crapser, John H. Crocker, William T. Good and Robert G. Smith; and Ensigns Leon F. Kinard, Robert W. Doyle and William H. Wagner, Jr. Two squadron personnel were awarded the Silver Star for their actions; they were: Lieutenants Donald F. Banker and Leonard R. Swanson.

**5–6 Nov 1944:** The squadron's final sorties involved attacks on Manila Bay and the successful sinking of a

Japanese Heavy Cruiser on 5 November. For their actions in the sinking of the cruiser, Lieutenants Donald F. Banker and Price R. Stradley were awarded Gold Stars in lieu of their second Navy Cross.

**26 Nov-14 Dec 1944:** The squadron and air group were relieved by CVG-20 and were enroute from Ulithi Atoll, via Hawaii, to the States.

### Home Port Assignments

<i>Location</i>	<i>Assignment Date</i>
NAAS Los Alamitos	15 Aug 1943
NAS Kahului	29 Feb 1944*
NAS Alameda	20 Jan 1945*
NAAS Santa Rosa	06 Feb 1945*
NAS Kahului	09 Aug 1945
NAS Barbers Point	04 Nov 1945
NAB Marpi Pt. and NAB Kobler, Saipan	01 Apr 1946†
NAS Alameda	19 Aug 1946

\* Temporary shore assignment while the squadron conducted training in preparation for combat deployment.

† Temporary shore assignment while the squadron was deployed to WestPac.

### Commanding Officers

	<i>Date Assumed Command</i>
LCDR Richard S. McGowan	15 Aug 1943
LT Donald F. Banker (acting)	24 Oct 1944
LT Price R. Stradley (acting)	05 Nov 1944
LT Robert D. Niemeyer	20 Jan 1945
LCDR William H. Craven, Jr.	Aug 1945
LCDR M. D. Norton, Jr.	06 Jun 1947
LCDR W. Denton, Jr.	13 Sep 1947
CDR Edwin J. Kroeger	24 Aug 1948

### Aircraft Assignment

<i>Type of Aircraft</i>	<i>Date Type First Received</i>
SBD-5	Sep 1943
SB2C-1	01 Apr 1944
SB2C-1C	May 1944
SB2C-3	Jun 1944
SB2C-4	Feb 1945
SB2C-4E	Feb 1945
SB2C-5	Aug 1945
AD-1	06 Dec 1946
AD-2	Sep 1948
AD-3	10 Jan 1949



*A squadron SB2C-5 Helldiver in flight, circa mid 1946 (Courtesy Robert Lawson Collection).*



**Major Overseas Deployments**

<i>Date of Departure</i>	<i>Date of Return</i>	<i>Air Wing</i>	<i>Carrier</i>	<i>Type of Aircraft</i>	<i>Area of Operation</i>
10 Jul 1944	23 Nov 1944	CVG-19	CV 16	SB2C-3	Pacific
20 Apr 1946	09 Aug 1946	CVG-19	CV 36*	SB2C-5	WestPac

\* During the squadron deployment to WestPac aboard *Antietam* (CV 36) it was temporarily shore based at Saipan on several occasions.

**Air Wing Assignments**

<i>Air Wing</i>	<i>Tail Code</i>	<i>Assignment Date</i>
CVG-19/CVAG-19*	A/B†	15 Aug 1943

\* CVG-19 was redesignated CVAG-19 on 15 November 1946.

† The tail code A was assigned to CVAG-19 on 12 December 1946. On 4 August 1948 CVG-19's tail code was changed to B.

**Unit Awards Received**

<i>Unit Award</i>	<i>Inclusive Dates Covering Unit Award</i>	
PUC	18 Jul 1944	05 Aug 1944
	06 Sep 1944	06 Nov 1944
Campaign Medal (Asiatic Pacific)	18 Jul 1944	27 Aug 1944
	31 Aug 1944	14 Oct 1944
	10 Oct 1944	23 Nov 1944



*A squadron AD-1 Skyraider launches from Princeton (CV 37), 1948 (Courtesy Robert Lawson Collection).*

## VA-196

### Lineage

Established as Fighter Squadron ONE HUNDRED FIFTY THREE (VF-153) on 15 July 1948.

Redesignated Fighter Squadron ONE HUNDRED NINETY FOUR (VF-194) on 15 February 1950.

Redesignated Attack Squadron ONE HUNDRED NINETY SIX (VA-196) on 4 May 1955. The first squadron to be assigned the VA-196 designation.



*The winged tiger, the squadron's first insignia, is not recorded as officially approved.*

### Squadron Insignia and Nickname

There is no record of approval by CNO for the squadron's first insignia. The colors for the winged tiger probably were: a white background outlined in red; gold wings with black markings; blue waves with black markings; the clouds shaded gray with

black outlines; yellow claws and tiger head, with black markings; and red lightning bolts with black markings.

A new insignia was approved by CNO on 5 October 1950. Colors for the devil and ace of spades insignia were: a white background with a black border; the devil was yellow with black markings; the machine gun, rocket and ammo belt were red with black markings; the ace of spades was black; and the lightning bolt was orange outlined in black.

Following the squadron's redesignation to VA-196, it continued to use the devil and ace of spades insignia until 14 September 1967 when CNO approved a new insignia. Colors for the ace of spades with the devil face is: an orange background with a black border; the



*The devil and ace of spades insignia was the squadron's second insignia and was used for 17 years.*



*The squadron modified its devil insignia in 1967 and adopted the devil face superimposed on the ace of spades.*

ace of spades is black; the devil's face is superimposed on the ace of spades and outlined in yellow, the teeth, eyes and horns are white with black pupils and black markings on the horns; the scroll has a white background outlined in black, with black lettering.

Nicknames: Thundercats, 1948–1950s.

The Main Battery, 1950s–present.

Beginning in 1979 the squadron used Milestones interchangeably with its nickname Main Battery.

### Chronology of Significant Events

**11 Dec 1951:** The squadron flew its first combat sorties, flying interdiction missions in Korea against enemy lines of communications, transportation, industrial and supply facilities.

**22 Mar 1952:** During a bombing run on a rail line north of Kowon, Korea, Ensign K. A. Schechter was wounded when an enemy shell struck the canopy of his AD Skyraider and exploded. He was blinded by the blood from the wound causing him to maneuver erratically. Lieutenant (jg) J. H. Thayer, heard Ensign Schechter's call for assistance and observing his erratic maneuvering, flew alongside and began giving radio instructions to the blinded pilot. Using Lieutenant Thayer's radio guidance, Ensign Schechter flew his plane to an emergency air strip and successfully landed the aircraft.

**Feb 1955:** In January 1955, the People's Republic of China began bombardment of the Tachen Islands held by Nationalist China. In February squadron aircraft provided air cover during the evacuation of Chinese Nationalist military and civilian personnel from the islands.

**Aug–Oct 1964:** The squadron was involved in operations off the coast of Vietnam following the Tonkin Gulf Incident.

**21 Aug 1967:** The squadron's commanding officer, Commander L. T. Profilet and his NFO Lieutenant Commander W. M. Hardman, were shot down and taken prisoner during a mission over North Vietnam. They were released by North Vietnam and returned to the U.S. on 29 March 1973.

**Dec 1971:** Following the outbreak of war between India and Pakistan over East Pakistan (Bangladesh), *Enterprise* (CVAN 65) was ordered to leave Yankee Station for operations in the Indian Ocean. The carrier, with VA-196 embarked, operated in the Bay of Bengal until the early part of January 1972 and cessation of hostilities.

**Oct 1972:** The squadron participated in Linebacker I operations, heavy air strikes against targets in North Vietnam to interdict the flow of supplies into South Vietnam.

**Dec 1972:** Squadron aircraft participated in Linebacker II operations, an intensified version of Linebacker I.

**Feb–May 1973:** Squadron aircraft flew air support for Operation End Sweep, the clearing of mines from North Vietnamese waters.

**Apr 1975:** The squadron, along with other CVW-14 units, provided air cover support during the evacuation of personnel from Saigon as it fell to the communists.

**Feb 1977:** During the crisis in Uganda and threats against Americans in that country, *Enterprise*, with VA-196 embarked, operated off the coast of Kenya ready to evacuate Americans from Uganda.

**Dec 1979:** *Coral Sea* (CV 43), with VA-196 embarked, operated off the coast of South Korea following the assassination of South Korea's President Park Chung-Hee in late October.

**Apr 1980:** *Coral Sea*, with the squadron embarked, was part of the task force involved in supporting the Iranian hostage rescue attempt.

**May 1980:** Following civil unrest in South Korea, the squadron, embarked in *Coral Sea*, operated off the coast of that country.

**Aug 1983:** Due to the unsettled conditions in Central America, *Coral Sea*, with VA-196 embarked, operated

off the coast of Nicaragua and also participated in surveillance for illegal drug traffic.

**Jul 1987:** Due to the increased attacks on merchant and tanker shipping in the Persian Gulf during the Iran/Iraqi War, the United States began to escort reflagged Kuwaiti oil tankers. During operation Earnest Will, VA-196 provided air support for the first convoy of reflagged tankers passing through the Strait of Hormuz.

**Aug 1990:** Due to the invasion of Kuwait by Iraq, *Independence* (CV 62), with VA-196 embarked, was ordered to the North Arabian Sea.

**Aug–2 Oct 1990:** VA-196 flew sorties from *Independence* in support of Operation Desert Shield, the build up of American and Allied forces to counter a threatened invasion of Saudi Arabia by Iraq.

**2 Oct–2 Nov 1990:** On 2 October, *Independence* entered the Persian Gulf and operated in those waters for two days before returning to the Northern Arabian Sea. VA-196 continued flying sorties for operation Desert Shield until *Independence* was relieved on 2 November and departed for its return trip to the States.



*A squadron F8F-2 Bearcat on the elevator being brought up to the flight deck, 1950 (Courtesy Robert Lawson Collection).*

**Home Port Assignments**

<i>Location</i>	<i>Assignment Date</i>
NAS Alameda	15 Jul 1948
NAS Moffett Field	23 Feb 1959
NAS Lemoore	Feb 1963
NAS Oceana	01 May 1966
NAS Whidbey Island	15 Nov 1966

**Commanding Officers**

	<i>Date Assumed Command</i>
LCDR Eugene W. Krebsbach (acting)	15 Jul 1948
CDR Thomas D. Harris	26 Jul 1948
LCDR Theodore C. Schaible	05 Dec 1949
LCDR Robert S. Schreiber	06 Dec 1950
LCDR Arthur N. Melhuse	19 Aug 1952
LCDR B. R. Trexler	Dec 1953
CDR R. B. Gibling	Jun 1955
LCDR Robert T. Lynn	Jan 1957
LCDR Dicky Wieland	18 Apr 1958
CDR R. R. Newman	01 Jul 1959
CDR G. P. Powers	01 Jun 1960
CDR J. L. Delaware	17 Mar 1961
CDR W. E. Edwards	09 Feb 1962
CDR W. P. Robinson	Dec 1962
CDR J. R. Driscoll	Jan 1964
CDR Joseph Gallagher	04 Jan 1965
CDR James A. Donovan	25 Jan 1966
CDR Leo T. Profilet	22 Dec 1966
CDR Edward C. Bauer	28 Aug 1967
CDR L. C. Dittmar	07 Feb 1969
CDR John R. Wunsch	12 Jun 1970
CDR Lloyd W. Richards	04 Jun 1971
CDR Howard I. Young	30 May 1972
CDR Jackson E. Cartwright	26 Jul 1973

**Commanding Officers—Continued**

	<i>Date Assumed Command</i>
CDR Gordon R. Nakagawa	12 Jul 1974
CDR Lyle F. Bull	23 Jun 1975
CDR John K. Peiguss	10 Sep 1976
CDR Gerald L. Smith	23 Nov 1977
CDR Thomas K. Woodka	18 Jan 1979
CDR David L. Russell	18 Jan 1980
CDR Robert E. Wilks	07 Aug 1981
CDR Kenneth L. Pyle	17 Dec 1982
CDR Harry A. Juplin	08 Jun 1984
CDR Thomas F. Cleverdon	06 Dec 1985
CDR Tom S. Fellin	16 May 1987
CDR Bruce T. Stuckert	12 Aug 1988
CDR David C. Nichols	09 Feb 1990

**Aircraft Assignment**

<i>Type of Aircraft</i>	<i>Date Type First Received</i>
F8F-1	Jul 1948
F8F-2	11 May 1949
F4U-4	Aug 1950
AD-3	Dec 1950
AD-1	Jan 1951
AD-2	Sep 1951
AD-4NA	Aug 1952
AD-4Q	Aug 1952
AD-6/A-1H*	Dec 1953
AD-7/A-1J*	Mar 1962
A-6A	01 Oct 1966
A-6B	Jun 1968
KA-6D	Mar 1971
A-6E	02 Jul 1975

\* The AD-6 and AD-7 designations were changed to A-1H and A-1J in 1962.

**Major Overseas Deployments**

<i>Date of Departure</i>	<i>Date of Return</i>	<i>Air Wing</i>	<i>Carrier</i>	<i>Type of Aircraft</i>	<i>Area of Operation</i>
11 Jan 1950	13 Jun 1950	CVG-19	CV 21	F8F-2	WestPac
15 Oct 1951	03 Jul 1952	ATG-1	CV 45	AD-2/3	Korea
30 Mar 1953	28 Nov 1953	ATG-1	CVA 21	AD-4NA/Q	Korea/WestPac
01 Sep 1954	09 Apr 1955	ATG-1	CVA 18	AD-6	WestPac
28 May 1956	20 Dec 1956	ATG-1	CVA 16	AD-6	WestPac
04 Oct 1958	17 Feb 1959	ATG-1	CVA 14	AD-6	WestPac
21 Nov 1959	14 May 1960	CVG-19	CVA 31	AD-6	WestPac
26 Apr 1961	13 Dec 1961	CVG-19	CVA 31	AD-6	WestPac
12 Jul 1962	11 Feb 1963	CVG-19	CVA 31	A-1H/J	WestPac
28 Jan 1964	21 Nov 1964	CVW-19	CVA 31	A-1H/J	WestPac/IO/Vietnam
21 Apr 1965	13 Jan 1966	CVW-19	CVA 31	A-1H/J	WestPac/Vietnam
29 Apr 1967	04 Dec 1967	CVW-14	CVA 64	A-6A	WestPac/Vietnam
29 May 1968	31 Jan 1969	CVW-14	CVA 64	A-6A/B	WestPac/Vietnam
14 Oct 1969	01 Jun 1970	CVW-2	CVA 61	A-6A	WestPac/Vietnam
11 Jun 1971	12 Feb 1972	CVW-14	CVAN 65	A-6A/B & KA-6D	WestPac/Vietnam/IO

**Major Overseas Deployments—Continued**

<i>Date of Departure</i>	<i>Date of Return</i>	<i>Air Wing</i>	<i>Carrier</i>	<i>Type of Aircraft</i>	<i>Area of Operation</i>
12 Sep 1972	12 Jun 1973	CVW-14	CVAN 65	A-6A/B & KA-6D	WestPac/Vietnam
17 Sep 1974	20 May 1975	CVW-14	CVAN 65	A-6A & KA-6D	WestPac/IO
30 Jul 1976	28 Mar 1977	CVW-14	CVN 65	A-6E & KA-6D	WestPac/IO
04 Apr 1978	30 Oct 1978	CVW-14	CVN 65	A-6E & KA-6D	WestPac/IO
13 Nov 1979	11 Jun 1980	CVW-14	CV 43	A-6E & KA-6D	WestPac/IO
20 Aug 1981	23 Mar 1982	CVW-14	CV 43	A-6E & KA-6D	WestPac/IO
21 Mar 1983	12 Sep 1983	CVW-14	CV 43	A-6E & KA-6D	World Cruise
21 Feb 1985	24 Aug 1985	CVW-14	CV 64	A-6E & KA-6D	WestPac/IO
04 Sep 1986	20 Oct 1986	CVW-14	CV 64	A-6E & KA-6D	NorPac
11 Apr 1987	13 Oct 1987	CVW-14	CV 64	A-6E & KA-6D	WestPac/IO
01 Dec 1988	01 Jun 1989	CVW-14	CV 64	A-6E & KA-6D	WestPac/IO
16 Sep 1989	19 Oct 1989	CVW-14	CV 64	A-6E & KA-6D	NorPac
23 Jun 1990	20 Dec 1990	CVW-14	CV 62	A-6E	WestPac/IO/ Persian Gulf



A squadron AD-6 Skyraider on the deck of Lexington (CVA 16) during deployment to WestPac in 1956.

**Air Wing Assignments**

<i>Air Wing</i>	<i>Tail Code</i>	<i>Assignment Date</i>
CVG-15	A	15 Jul 1948
CVG-19	B	01 Dec 1949
ATG-1	U/NA*	01 Jul 1951
COMFAIRALAMEDA		23 Feb 1959
CVG-19/CVW-19†	NM	22 Jun 1959
CVW-14	NK	15 Oct 1966
CVW-2	NE	02 Aug 1969
CVW-14	NK	01 Jun 1970

\* ATG-1 was not assigned a tail code designation until 1956 when it received the letter "U." Before then the squadron was using the tail code assigned to CVG-19. The tail code was changed from U to NA in 1957. The effective date for this change was most likely the beginning of FY 58 (1 July 1957).

† CVG-19 was redesignated CVW-19 when Carrier Air Groups (CVG) were redesignated Carrier Air Wings (CVW) on 20 December 1963.

**Unit Awards Received**

<i>Unit Award</i>	<i>Inclusive Dates Covering Unit Award</i>	
KSM	04 Dec 1951	19 Jun 1952
	30 Apr 1953	10 Nov 1953
KPUC	07 Dec 1951	20 Jun 1952
	12 May 1953	27 Jul 1953
NAVE	01 Jan 1982	30 Jun 1983
	12 Nov 1958	15 Nov 1958
AFEM	20 Nov 1958	22 Nov 1958
	05 Dec 1958	08 Dec 1958
	29 Dec 1958	01 Jan 1959
	03 Apr 1960	04 Apr 1960
	26 Apr 1960	27 Apr 1960
	22 May 1961	27 May 1961
	05 Mar 1964	13 Mar 1964
	12 May 1964	14 May 1964
	05 Jun 1964	10 Jun 1964
	13 Jun 1964	17 Jun 1964

**Unit Awards Received—Continued**

<i>Unit Award</i>	<i>Inclusive Dates Covering Unit Award</i>	
	31 Aug 1964	06 Nov 1964
	26 May 1965	03 Jul 1965
	10 Jan 1970	13 Jan 1970
	12 Apr 1970	13 Apr 1970
	29 Apr 1975	30 Apr 1975
RVNGC	19 Oct 1965	20 Oct 1965
	23 Oct 1965	28 Oct 1965
	22 Nov 1965	
	24 Nov 1965	
	06 Dec 1965	
VNSM	18 Jul 1965	13 Aug 1965
	10 Sep 1965	01 Oct 1965
	08 Oct 1965	29 Oct 1965
	13 Nov 1965	17 Dec 1965
	08 Jun 1967	11 Jun 1967
	18 Jul 1967	25 Jul 1967
	01 Aug 1967	03 Sep 1967
	25 Sep 1967	15 Oct 1967
	24 Oct 1967	12 Nov 1967
	27 Jun 1968	22 Jul 1968
	02 Aug 1968	28 Aug 1968
	11 Sep 1968	09 Oct 1968
	26 Oct 1968	29 Nov 1968
	09 Dec 1968	21 Dec 1968
	01 Jan 1969	07 Jan 1969
	16 Nov 1969	07 Dec 1969
	17 Dec 1969	06 Jan 1970

**Unit Awards Received—Continued**

<i>Unit Award</i>	<i>Inclusive Dates Covering Unit Award</i>	
	29 Jan 1970	18 Feb 1970
	27 Feb 1970	20 Mar 1970
	16 Apr 1970	13 May 1970
	14 Jul 1971	31 Jul 1971
	15 Aug 1971	04 Sep 1971
	12 Sep 1971	
	25 Sep 1971	26 Sep 1971
	19 Jan 1972	24 Jan 1972
	02 Oct 1972	23 Oct 1972
	01 Nov 1972	11 Dec 1972
	18 Dec 1972	13 Jan 1973
	24 Jan 1973	23 Feb 1973
	01 Mar 1973	02 Mar 1973
	11 Mar 1973	28 Mar 1973
MUC	14 Jun 1968	23 Jan 1969
	27 Oct 1969	12 May 1970
	02 Jul 1971	03 Feb 1972
	22 Apr 1975	30 Apr 1975
	07 Mar 1978	01 May 1980
	01 Jan 1984	24 Aug 1985
NUC	18 May 1967	26 Nov 1967
	03 Oct 1972	22 Feb 1973
	01 Jan 1982	30 Aug 1983
	02 Aug 1990	01 Nov 1990
HSM	29 Apr 1975	30 Apr 1975
NEM	01 Feb 1980	05 May 1980
	11 Oct 1981	20 Oct 1981
SASM	05 Aug 1990	04 Nov 1990



*A squadron A-6E Intruder on an exercise mission dropping snake eye bombs in 1988; Constellation (CV 64) is in the background.*

## VA-205

### Lineage

Established as Attack Squadron TWO HUNDRED FIVE (VA-205) on 1 July 1970.

Disestablished on 31 December 1994. The first squadron to be assigned the VA-205 designation.



The squadron's one and only insignia.

### Squadron Insignia and Nickname

The squadron's insignia was approved by CNO on 15 October 1971. Colors for the insignia are white and green: a white background and scroll outlined in green; green lettering; and green bomb and falcon with white markings.

Nickname: Green Falcons, 1971–1994.

### Chronology of Significant Events

**1 Jul 1970:** VA-205, a reserve squadron, was established as part of a reorganization intended to increase the combat readiness of the Naval Air Reserve Force.

**Aug 1971:** The squadron conducted its two weeks of active duty training embarked on *John F. Kennedy* (CVA 67) as part of CVWR-20. This was the first complete Reserve Carrier Air Wing deployment aboard a carrier.

**May 1972:** The squadron participated in exercise Exotic Dancer V, designed to test multi-service operations under a unified command organization.

**4 Sep 1975:** Squadron pilots began transition training with VA-125 in preparation for receiving the A-7 Corsair II.

**6–16 Jul 1982:** The squadron, along with other units of CVWR-20, participated in operations on *Carl Vinson* (CVN 70), with the emphasis on coordinated air wing operations.

**10–23 May 1986:** During an annual active duty deployment to NAS Fallon, the squadron participated in close air support training, air wing strike evolutions, and an excellent simulated two day war exercise conducted by Strike University.

**1 Oct 1993:** The squadron assumed the additional mission (Fleet Support Readiness Group, FTRG) of providing electronic support to simulate missile attacks on surface ships for training purposes. This mission had previously been performed by VAQ-33 (Carrier Tactical Electronics Warfare Squadron-33).



A squadron A-4L Skyhawk at NAS Atlanta, Georgia, 1973.

### Home Port Assignments

Location	Assignment Date
NAS Atlanta	01 Jul 1970

### Commanding Officers

	Date Assumed Command
CDR John B. Barnes	01 Jul 1970
CDR Virgil R. Tedder	12 Feb 1972
CDR Jack S. Smith	21 Jul 1973
LCDR David K. Maskell	19 Jul 1975
CDR Robert D. Sibold	16 Jan 1977
CDR James G. Bailey	20 Aug 1978
CDR Gadsden S. Gause	24 Feb 1980
CDR Gary C. Ayers	25 Oct 1981
CDR John D. Kish	24 Apr 1983
CDR Robert T. Golden	21 Oct 1984
CDR Michael C. Crabtree	27 Apr 1986
CDR Dana F. Miller	25 Oct 1987
CDR Daniel E. Caldwell	23 Oct 1988
CDR Randall C. Schultz	28 Apr 1990
CDR M. Kent Horne	19 Oct 1991
CDR Thomas R. McInvale	15 Aug 1992
CDR Kent D. White	06 Nov 1993



A squadron A-7B Corsair II in flight, circa late 1970s or early 1980s.

**Aircraft Assignment**

<i>Type of Aircraft</i>	<i>Date Type First Received</i>
A-4L	01 Oct 1970
A-7B	26 Sep 1975
A-7E	20 Jun 1984
KA-6D	22 Aug 1990
A-6E	17 Nov 1990

**Air Wing Assignments**

<i>Air Wing</i>	<i>Tail Code</i>	<i>Assignment Date</i>
CVWR-20	AF	01 Jul 1970

**Unit Awards Received**

<i>Unit Award</i>	<i>Inclusive Dates Covering Unit Award</i>	
MUC	01 Jul 1977	31 Dec 1978
NAVE	01 Oct 1981	31 Dec 1982



*A squadron A-6E Intruder at NAS Fallon, Nevada, 1992 (Courtesy Robert Lawson Collection).*



## VA-209

### Lineage

Established as Reserve Attack Squadron TWO HUNDRED NINE (VA-209) on 1 July 1970.

Disestablished on 15 August 1971. The first squadron to be assigned the VA-209 designation.

### Squadron Insignia and Nickname

There is no record of an officially approved insignia for the squadron.

Nickname: unknown.

### Chronology of Significant Events

**1 Jul 1970:** VA-209 was a reserve squadron established as part of a reorganization intended to increase the combat readiness of the Naval Air Reserve Force.

**15 Aug 1971:** The squadron was disestablished due to its replacement by the addition of two fighter squadrons to Reserve Air Wing 20.

### Home Port Assignments

<i>Location</i>	<i>Assignment Date</i>
NAS Glenview	01 Jul 1970

### Commanding Officers

	<i>Date Assumed Command</i>
CDR William J. Miller	01 Jul 1970

### Aircraft Assignment

<i>Type of Aircraft</i>	<i>Date Type First Received</i>
A-4L	01 Jul 1970

### Air Wing Assignments

<i>Air Wing</i>	<i>Tail Code</i>	<i>Assignment Date</i>
CVWR-20	AF	01 Jul 1970



*Squadron A-4L Skyhawks in flight over Chicago, Illinois, circa 1971.*

## VA-210

### *Lineage*

Established as Reserve Attack Squadron TWO HUNDRED TEN (VA-210) on 1 July 1970.

Disestablished on 30 June 1971. The first squadron to be assigned the VA-210 designation.

### *Squadron Insignia and Nickname*

The squadron's insignia was approved by CNO on 15 April 1970. Colors for the insignia were: sky blue background with three concentric rings of yellow,



*The squadron's one and only insignia.*

dark blue and yellow, all outlined in black; yellow lightning bolt; black aircraft and flag staff; red pennants; dark blue waves; and a white scroll outlined in black with black lettering.

Nickname: Unknown.

### *Chronology of Significant Events*

**1 Jul 1970:** VA-210 was a reserve squadron established as part of a reorganization intended to increase the combat readiness of the Naval Air Reserve Force. Assets from reserve squadron VA-2Z1 were utilized to form VA-210.

**14 Dec 1970:** The squadron conducted its last operational flight.

**30 Jun 1971:** The squadron was disestablished due to its replacement by the addition of two fighter squadrons to Reserve Air Wing 20.

### *Home Port Assignments*

	<i>Location Assignment Date</i>
NAS South Weymouth	01 Jul 1970

### *Commanding Officers*

	<i>Date Assumed Command</i>
CDR W. M. Hollister	01 Jul 1970

### *Aircraft Assignment*

<i>Type of Aircraft</i>	<i>Date Type First Received</i>
TA-4B	1970*
A-4C	1970*

\* These aircraft were operated by VA-210 but may not have been permanently assigned to the squadron.

### *Air Wing Assignments*

<i>Air Wing</i>	<i>Tail Code</i>	<i>Assignment Date</i>
CVWR-20	AF	01 Jul 1970

## VA-212

### Lineage

Established as Fighter Squadron TWO HUNDRED TWELVE (VF-212) on 20 June 1955.

Redesignated Attack Squadron TWO HUNDRED TWELVE (VA-212) on 1 April 1956.

Disestablished on 12 December 1975. The first to be assigned the VA-212 designation.



The squadron's rampant lion insignia.

### Squadron Insignia and Nickname

The squadron's insignia was approved by CNO on 4 September 1956. Colors for the insignia were: a black background outlined in yellow; yellow rampant lion; black scrolls outlined in yellow with yellow lettering.

Nickname: Rampant Raiders, 1956–1975.

### Chronology of Significant Events

**6 Jun 1958:** The squadron's commanding officer, Commander G. W. Staeheli, was killed in an aircraft accident.

**Aug-Sep 1958:** VA-212, embarked on *Lexington* (CVA 16), operated in the Formosa Straits due to the tension surrounding the Chinese Communist shelling of the Quemoy Islands.

**Apr 1959:** VA-212 became the first operational squadron to deploy with the Bullpup air-to-ground missile.

**Mar 1961:** *Lexington* (CVA 16), with VA-212 embarked, was ordered to operate off the coast of Thailand as a result of the deteriorating position of Laotian government forces against the Communists. Units of *Lexington's* air group flew reconnaissance missions over Laos while on station.

**15 Apr 1962:** VA-212, embarked in *Hancock* (CVA 19), operated off the coast of South Vietnam during the arrival of the first USMC advisory unit in the Republic of Vietnam.

**16–20 May 1962:** Following the continued successes of the Pathet Lao forces against Laotian government forces, particularly along the border with Thailand, the Thai government requested U.S. support. A unit of U.S. Marines landed in Bangkok and moved by air to Udorn. VA-212, along with other units of CVG-21, embarked in *Hancock*, operated in the area and were available to provide air support for the Marines if required.

**Sep 1963:** VA-212, embarked in *Hancock*, operated off the coast of Taiwan due to increased tensions between the People's Republic of China and the Republic of China.

**Nov 1963:** *Hancock*, with VA-212 embarked, operated off the coast of South Vietnam following the coup that overthrew President Diem.

**7 Feb 1965:** Following the shelling of an American advisors' compound at Pleiku by the Viet Cong, VA-212 participated in reprisal attacks against targets in North Vietnam. During the strikes, named Flaming Dart I, VA-212's Skyhawks struck the Dong Hoi Barracks.

**11 Feb 1965:** VA-212's Skyhawks participated in Flaming Dart II operations, reprisal attacks against the barracks at Chanh Hoa.

**Mar-May 1965:** The squadron's Skyhawks participated in special operations in Southeast Asia, including the Rolling Thunder campaign, strikes against designated military targets in North Vietnam.

**Mar 1966:** Squadron aircraft participated in Operation Jackstay, providing combat air support for amphibious operations that cleared the Rung Sat zone southeast of Saigon.

**30 Jun 1966:** Commander H. L. Smith, the squadron's commanding officer, was awarded the Silver Star for leading an air strike against the Bac Giang POL facility.

**Oct-Nov 1966:** During the squadron's training cycle, its aircraft were modified to incorporate the Walleye weapons system, becoming the first fleet unit equipped with the new system.

**11 Mar 1967:** The squadron's commanding officer, Commander H. L. Smith, conducted the first combat Walleye attack, striking the Sam Son Army Barracks.

**20 May 1967:** Commander H. L. Smith was awarded the Navy Cross for his action during strikes on the Bac Giang Thermal Power Plant on 19 and 20 May. He was killed in action during the mission on 20 May.

**Feb-Mar 1968:** Squadron aircraft flew combat air support missions for the Marines under siege at Khe Sahn.

**Apr 1972:** With the North Vietnamese invasion of South Vietnam, the Easter Offensive, the squadron concentrated its strikes in the area of An Loc, South Vietnam. It provided combat air support for U.S. and South Vietnamese ground forces defending the city.

**May 1972:** VA-212 participated in Operation Linebacker I, heavy air strikes against targets in North Vietnam.

**25 May 1972:** The squadron's commanding officer, Commander H. H. Strong, was killed in action when his aircraft was hit by antiaircraft fire during a strike near Vinh, North Vietnam.

**Oct-Dec 1973:** With the outbreak of war in the Middle East between Israel, Syria and Egypt and the initiation of the Arab oil embargo, *Hancock*, with VA-212 embarked, was ordered to enter the Indian Ocean and operate in the Arabian Sea.



A squadron F7U-3 Cutlass catching the wire aboard Bon Homme Richard (CVA 31) in July 1956 (Courtesy Duane Kasulka Collection).

### Home Port Assignments

<i>Location</i>	<i>Assignment Date</i>
NAS Moffett Field	20 Jun 1955
NAS Lemoore	15 Sep 1961

### Commanding Officers

	<i>Date Assumed Command</i>
LCDR D. R. Hagood	20 Jun 1955
LCDR T. H. Cooper	Feb 1957
CDR G. W. Staeheli	23 Apr 1958
LCDR L. Krupp (acting)	06 Jun 1958
CDR Jack C. Stuart	13 Jun 1958
CDR Meryl A. Iiams	30 Dec 1959
CDR Emmett B. Boutwell	05 Jul 1961
CDR N. J. Gambrill	11 Jun 1962
CDR Frank T. Hemler	22 Jun 1963
CDR W. B. Muncie	09 Jul 1964
CDR K. L. Shugart	01 Jun 1965
CDR Holmer L. Smith	01 Jun 1966
CDR Marvin M. Quaid	May 1967

### Commanding Officers—Continued

	<i>Date Assumed Command</i>
CDR Richard R. Allmann	09 Jul 1968
CDR David C. Coe, Jr.	21 Feb 1969
CDR Edwin D. Shropshire	22 Dec 1969
CDR Thomas M. Corkhill	13 Nov 1970
CDR Henry H. Strong, Jr.	17 Dec 1971
CDR Robert W. Peacher	25 May 1972
CDR Milton R. Gorham	02 May 1973
CDR James M. Curtin	31 May 1974

### Aircraft Assignment

<i>Type of Aircraft</i>	<i>Date Type First Received</i>
F7U-3M	Jul 1955
F7U-3	Aug 1955
F9F-8B	Apr 1957
FJ-4B	19 Jul 1957
A4D-2/A-4B*	20 Jun 1961
A-4E	02 Jan 1964
A-4F	Oct 1967

\* The A4D-2 designation was changed to A-4B in 1962.

**Major Overseas Deployments**

<i>Date of Departure</i>	<i>Date of Return</i>	<i>Air Wing</i>	<i>Carrier</i>	<i>Type of Aircraft</i>	<i>Area of Operation</i>
16 Aug 1956	28 Feb 1957	CVG-21	CVA 31	F7U-3	WestPac
14 Jul 1958	19 Dec 1958	CVG-21	CVA 16	FJ-4B	WestPac
26 Apr 1959	02 Dec 1959	CVG-21	CVA 16	FJ-4B	WestPac
29 Oct 1960	06 Jun 1961	CVG-21	CVA 16	FJ-4B	WestPac
02 Feb 1962	24 Aug 1962	CVG-21	CVA 19	A4D-2	WestPac
07 Jun 1963	16 Dec 1963	CVG-21	CVA 19	A-4B	WestPac
21 Oct 1964	29 May 1965	CVW-21	CVA 19	A-4E	WestPac/Vietnam
10 Nov 1965	01 Aug 1966	CVW-21	CVA 19	A-4E	WestPac/Vietnam
26 Jan 1967	25 Aug 1967	CVW-21	CVA 31	A-4E	WestPac/Vietnam
27 Jan 1968	10 Oct 1968	CVW-5	CVA 31	A-4F	WestPac/Vietnam
02 Aug 1969	15 Apr 1970	CVW-21	CVA 19	A-4F	WestPac/Vietnam
22 Oct 1970	03 Jun 1971	CVW-21	CVA 19	A-4F	WestPac/Vietnam
07 Jan 1972	03 Oct 1972	CVW-21	CVA 19	A-4F	WestPac/Vietnam
08 May 1973	08 Jan 1974	CVW-21	CVA 19	A-4F	WestPac/IO
18 Mar 1975	20 Oct 1975	CVW-21	CV 19	A-4F	WestPac



A squadron FJ-4B Fury preparing for launch from Lexington (CVA 16) during her 1959 deployment to WestPac.

**Air Wing Assignments**

<i>Air Wing</i>	<i>Tail Code</i>	<i>Assignment Date</i>
CVG-21/CVW-21†	G/NP*	01 Jul 1955
CVW-5	NF	01 Oct 1967
CVW-21	NP	01 Nov 1968

\* The tail code was changed from G to NP in 1957. The effective date for this change was most likely the beginning of FY 58 (1 July 1957).

† CVG-21 was redesignated CVW-21 when Carrier Air Groups (CVG) were redesignated Carrier Air Wings (CVW) on 20 December 1963.

**Unit Awards Received**

<i>Unit Award</i>	<i>Inclusive Dates Covering Unit Award</i>	
AFEM	15 Aug 1958	17 Aug 1958
	27 Aug 1958	16 Sep 1958
	14 Sep 1958	
	26 Sep 1958	15 Oct 1958

**Unit Awards Received—Continued**

<i>Unit Award</i>	<i>Inclusive Dates Covering Unit Award</i>		
NUC	02 Oct 1958		
	06 Oct 1958		
	10 Nov 1958	15 Nov 1958	
	27 Nov 1958	28 Nov 1958	
	28 Jun 1959	02 Jul 1959	
	11 Jul 1959	16 Jul 1959	
	17 Oct 1959	19 Oct 1959	
	15 Dec 1960	24 Dec 1960	
	01 Jan 1961	08 Jan 1961	
	10 Mar 1962	14 Mar 1962	
	14 Apr 1962	16 Apr 1962	
	16 May 1962	18 May 1962	
	04 Nov 1963	10 Nov 1963	
	07 Dec 1964	04 May 1965	
	04 May 1968	07 May 1968	
MUC	30 Oct 1969		
	03 Jan 1970	08 Jan 1970	
	22 Feb 1970	25 Feb 1970	
	06 Dec 1965	25 Jul 1966	
	21 Feb 1968	13 Sep 1968	
	08 Feb 1972	14 Sep 1972	
	21 Aug 1969	31 Mar 1970	
	20 Nov 1970	07 May 1971	
	RVNGC	26 Dec 1965	
		28 Dec 1965	31 Dec 1965
02 Jan 1966		04 Jan 1966	
09 Jan 1966			
15 Jan 1966		19 Jan 1966	
25 Feb 1966		26 Feb 1966	
28 Feb 1966		05 Mar 1966	
01 Apr 1966		02 Apr 1966	
25 May 1966			
24 Jun 1966			
27 Jun 1966	29 Jun 1966		

**Unit Awards Received—Continued**

<i>Unit Award</i>	<i>Inclusive Dates Covering Unit Award</i>	
	28 Feb 1967	
	07 Mar 1967	
	11 Mar 1967	
	13 Mar 1967	
	16 Mar 1967	
	20 Mar 1967	21 Mar 1967
	29 Apr 1967	01 May 1967
	16 May 1967	18 May 1967
	21 Feb 1968	25 Feb 1968
	27 Feb 1968	07 Mar 1968
	12 Mar 1968	18 Mar 1968
	22 Mar 1968	23 Mar 1968
	25 Mar 1968	
	06 Apr 1968	11 Apr 1968
	13 Apr 1968	14 Apr 1968
	17 Apr 1968	20 Apr 1968
	13 May 1968	14 May 1968
	26 May 1968	27 May 1968
	04 Jul 1968	
	02 Aug 1968	18 Aug 1968
	27 Aug 1968	14 Sep 1968
	30 Mar 1972	15 Jul 1972
VNSM	17 Dec 1965	23 Jan 1966
	11 Feb 1966	06 Mar 1966
	21 Mar 1966	10 Apr 1966
	27 Apr 1966	09 Jul 1966
	25 Feb 1967	21 Mar 1967
	17 Apr 1967	07 May 1967

**Unit Awards Received—Continued**

<i>Unit Award</i>	<i>Inclusive Dates Covering Unit Award</i>	
	01 Jun 1967	18 Jun 1967
	27 Jun 1967	31 Jul 1967
	20 Feb 1968	25 Mar 1968
	06 Apr 1968	20 Apr 1968
	09 May 1968	30 May 1968
	04 Jun 1968	05 Jun 1968
	13 Jun 1968	07 Jul 1968
	21 Jul 1968	18 Aug 1968
	27 Aug 1968	14 Sep 1968
	31 Aug 1969	25 Sep 1969
	03 Oct 1969	28 Oct 1969
	23 Nov 1969	18 Dec 1969
	17 Jan 1970	12 Feb 1970
	07 Mar 1970	27 Mar 1970
	18 Nov 1970	08 Dec 1970
	29 Dec 1970	15 Jan 1971
	23 Jan 1971	20 Feb 1971
	09 Mar 1971	15 Mar 1971
	17 Mar 1971	10 Apr 1971
	17 Apr 1971	04 May 1971
	07 Feb 1972	09 Mar 1972
	25 Mar 1972	02 May 1972
	11 May 1972	01 Jun 1972
	12 Jun 1972	14 Jul 1972
	24 Jul 1972	17 Aug 1972
	27 Aug 1972	14 Sep 1972
PUC	26 Feb 1967	30 Jul 1967



*A squadron A-4E Skyhawk preparing to launch on a combat mission from Bon Homme Richard (CVA 31) during her deployment to Vietnam in 1967.*

## VA-213

### *Lineage*

Established as Attack Squadron TWO HUNDRED THIRTEEN (VA-213) on 15 September 1948.

It is believed the squadron was disestablished sometime in May 1949. It was the first squadron to be assigned the VA-213 designation.

### *Squadron Insignia and Nickname*

There is no record of an officially approved insignia for the squadron.

Nickname: unknown.

### *Chronology of Significant Events*

**Sep 1948:** The squadron was established with the mission of being an all-weather attack unit and part of a carrier air group that was to be all-weather capable. Squadron personnel attended instrument training at the Fleet All-Weather Training Unit, Pacific.

### *Home Port Assignments*

<i>Location</i>	<i>Assignment Date</i>
NAS Seattle	15 Sep 1948

### *Commanding Officers*

	<i>Date Assumed Command</i>
LCDR H. Suerstedt, Jr.	15 Sep 1948

### *Aircraft Assignment*

<i>Type of Aircraft</i>	<i>Date Type First Received</i>
TBM-3E	Jan 1949

### *Air Wing Assignments*

<i>Air Wing</i>	<i>Tail Code</i>	<i>Assignment Date</i>
CVG-21	*	15 Sep 1948

\* There is no record of a tail code being assigned to CVG-21 for the period of its existence from 15 September 1948 to 15 March 1949.

## VA-214

### *Lineage*

Established as Attack Squadron TWO HUNDRED FOURTEEN (VA-214) on 15 September 1948.

Disestablished on 16 May 1949. The first squadron to be assigned the VA-214 designation.

### *Squadron Insignia and Nickname*

There is no record of an officially approved insignia for the squadron.

Nickname: unknown.

### *Chronology of Significant Events*

**Sep 1948:** The squadron was established with the mission of being an all-weather attack unit and part of a carrier air group that was to be all-weather capable. Squadron personnel attended instrument training at the Fleet All-Weather Training Unit, Pacific.

### *Home Port Assignments*

<i>Location</i>	<i>Assignment Date</i>
NAS Seattle	15 Sep 1948

### *Commanding Officers*

	<i>Date Assumed Command</i>
LT William H. Bartles (acting)	15 Sep 1948
LCDR Joseph A. Riley	Nov 1948

### *Aircraft Assignment*

<i>Type of Aircraft</i>	<i>Date Type First Received</i>
TBM-3E	Jan 1949

### *Air Wing Assignments*

<i>Air Wing</i>	<i>Tail Code</i>	<i>Assignment Date</i>
CVG-21	*	15 Sep 1948

\* There is no record of a tail code being assigned to CVG-21 for the period of its existence from 15 September 1948 to 15 March 1949.



## SECOND VA-214

### Lineage

Established as Fighter Squadron TWO HUNDRED FOURTEEN (VF-214) on 30 March 1955.

Redesignated Attack Squadron TWO HUNDRED FOURTEEN (VA-214) on 11 October 1956.

Disestablished on 1 August 1958. The second squadron to be assigned the VA-214 designation.

### Squadron Insignia and Nickname



The squadron's thunderbird insignia.

The squadron's insignia was approved by CNO on 5 December 1955. Colors for the thunderbird insignia were: a light blue background with a yellow border; black stylized thunderbird; yellow and red flame; and white double arrow shafts.

Nickname: Volunteers, 1957–1958.

### Chronology of Significant Events

6 Jan 1958: VA-214 was the first squadron on the west coast to make an extended deployment to the western Pacific with the new FJ-4B Fury.

### Home Port Assignment

Location	Assignment Date
NAS Moffett Field	30 Mar 1955



The squadron's acting commanding officer, Lieutenant Commander R. M. Soule, delivering the squadron's first aircraft, an FJ-3 Fury, at NAS Moffett Field, California, March 1955.

### Commanding Officers

	Date Assumed Command
LCDR R. M. Soule (acting)	30 Mar 1955
CDR L. T. Raynor	07 Jun 1955
CDR R. D. King	21 Sep 1956

### Aircraft Assignment

Type of Aircraft	Date Type First Received
FJ-3	31 Mar 1955
F9F-8	Nov 1955
FJ-4B	18 Jun 1957



A squadron F9F-8 Cougar aboard Yorktown (CVA-10), circa 1956 (Courtesy Robert Lawson Collection).

**Major Overseas Deployments**

<i>Date of Departure</i>	<i>Date of Return</i>	<i>Air Wing</i>	<i>Carrier</i>	<i>Type of Aircraft</i>	<i>Area of Operation</i>
19 Mar 1956	13 Sep 1956	ATG-4	CVA 10	F9F-8	WestPac
06 Jan 1958	02 Jul 1958	ATG-4	CVA 12	FJ-4B	WestPac

**Air Wing Assignments**

<i>Air Wing</i>	<i>Tail Code</i>	<i>Assignment Date</i>
ATG-4	Z*/ND†	30 Mar 1955

\* The tail code Z for ATG-4 was assigned on 24 July 1956.

† The tail code was changed from Z to ND in 1957. The effective date for this change was most likely the beginning of FY 58 (1 July 1957).



*A flight of squadron FJ-4Bs, circa 1957 or 1958.*

## VA-215

### Lineage

Established as Attack Squadron TWO HUNDRED FIFTEEN (VA-215) on 22 June 1955.

Disestablished on 31 August 1967. The first squadron to be assigned the VA-215 designation.



The barn owl insignia used by the squadron.

### Squadron Insignia and Nickname

The squadron's insignia was approved by CNO on 20 August 1956. The insignia colors are not on record.

Nickname: Barn Owls, early 1960's–1967.

### Chronology of Significant Events

**Aug–Nov 1958:** VA-215, operating from *Lexington* (CVA 16), conducted flight operations in the Formosa Straits due to the tension surrounding the Chinese Communist shelling of the Quemoy Islands.

**24 Mar 1959:** The squadron's commanding officer, Commander P. Rippa, was killed on a training flight in Yosemite Valley.

**Mar 1961:** *Lexington*, with VA-215 embarked, operated off the coast of Thailand as a result of the deteriorating position of Laotian government forces against the Pathet Lao. Units of *Lexington's* air group flew reconnaissance missions over Laos.

**15 Apr 1962:** Embarked in *Hancock* (CVA 19), the squadron operated off the coast of South Vietnam during the arrival of the first USMC advisor unit in the Republic of Vietnam.

**May 1962:** VA-215 and other CVG-21 squadrons from *Hancock* were prepared to support a U.S. Marine Corps unit that landed in Bangkok and moved by air to Udorn. The Marine landing was at the request of the Thai government because of its concerns surround-

ing the success of Pathet Lao forces along the Thai-Laotian border.

**Sep 1963:** VA-215, embarked in *Hancock*, operated off the coast of Taiwan due to increased tensions between the People's Republic of China and the Republic of China.

**Nov 1963:** VA-215, embarked in *Hancock*, operated off the coast of South Vietnam following the coup that overthrew President Diem.

**Dec 1964:** Squadron aircraft participated in its first Barrell Roll operations, armed reconnaissance and strike missions along infiltration routes in Laos.

**Feb 1965:** Skyraiders from the squadron participated in Flaming Dart operations, reprisal attacks against military targets in North Vietnam.

**Mar–May 1965:** The squadron's Skyraiders participated in special operations in Southeast Asia, including the Rolling Thunder campaign, strikes against designated military targets in North Vietnam.

**5 Mar 1966:** The squadron's commanding officer, Commander R. C. Hessom, was killed in action during a mission over North Vietnam.

**Mar 1966:** Squadron aircraft participated in Operation Jackstay, providing close air support for amphibious operations that cleared the Rung Sat zone, the river channels, southeast of Saigon.

### Home Port Assignments

Location	Assignment Date
NAS Moffett Field	Jun 1955
NAS Alameda	Dec 1963

### Commanding Officers

	Date Assumed Command
CDR E. E. Kerr	Jun 1955
LCDR W. A. Skon	Mar 1957
CDR O. N. Ford	Apr 1958
LCDR Peter Rippa	Jan 1959
LCDR J. L. Morrison, Jr. (acting)	24 Mar 1959
CDR H. Broadbent, Jr.	03 Apr 1959
CDR G. A. Buckowski	04 Apr 1960
CDR L. A. Dewing	12 Jun 1961
CDR F. W. Brown, Jr.	12 Jun 1962
CDR Richard J. Licko	22 Jun 1963
CDR Donald E. Brubaker	03 Jun 1964
CDR Robert C. Hessom	01 Mar 1965
CDR Frederick L. Nelson	05 Mar 1966
CDR George A. Carlton	Jan 1967

### Aircraft Assignment

Type of Aircraft	Date Type First Received
AD-6*	Aug 1955
AD-7*	Jun 1961

\* The AD-6 and AD-7 designations were changed to A-1H and A-1J in 1962.

**Major Overseas Deployments**

<i>Date of Departure</i>	<i>Date of Return</i>	<i>Air Wing</i>	<i>Carrier</i>	<i>Type of Aircraft</i>	<i>Area of Operation</i>
16 Aug 1956	28 Feb 1957	CVG-21	CVA 31	AD-6	WestPac
14 Jul 1958	19 Dec 1958	CVG-21	CVA 16	AD-6	WestPac
26 Apr 1959	02 Dec 1959	CVG-21	CVA 16	AD-6	WestPac
29 Oct 1960	06 Jun 1961	CVG-21	CVA 16	AD-6	WestPac
02 Feb 1962	24 Aug 1962	CVG-21	CVA 19	AD-6/7	WestPac
07 Jun 1963	16 Dec 1963	CVG-21	CVA 19	A-1H/J	WestPac
21 Oct 1964	29 May 1965	CVW-21	CVA 19	A-1H/J	WestPac/Vietnam
10 Nov 1965	01 Aug 1966	CVW-21	CVA 19	A-1H/J	WestPac/Vietnam
26 Jan 1967	25 Aug 1967	CVW-21	CVA 31	A-1H/J	WestPac/Vietnam

**Air Wing Assignments**

<i>Air Wing</i>	<i>Tail Code</i>	<i>Assignment Date</i>
CVG-21/CVW-21†	G/NP*	01 Jul 1955

\* The tail code was changed from G to NP in 1957. The effective date for this change was most likely the beginning of FY 58 (1 July 1957).

† CVG-21 was redesignated CVW-21 when Carrier Air Groups (CVG) were redesignated Carrier Air Wings (CVW) on 20 December 1963.

**Unit Awards Received**

<i>Unit Award</i>	<i>Inclusive Dates Covering Unit Award</i>	
AFEM	15 Aug 1958	17 Aug 1958
	27 Aug 1958	16 Sep 1958
	14 Sep 1958	
	26 Sep 1958	15 Oct 1958
	02 Oct 1958	
	06 Oct 1958	
	10 Nov 1958	15 Nov 1958
	27 Nov 1958	28 Nov 1958
	28 Jun 1959	02 Jul 1959
	11 Jul 1959	16 Jul 1959
	17 Oct 1959	19 Oct 1959
	15 Dec 1960	24 Dec 1960
	01 Jan 1961	08 Jan 1961
	10 Mar 1962	14 Mar 1962
	14 Apr 1962	16 Apr 1962
	16 May 1962	18 May 1962
	04 Nov 1963	10 Nov 1963
	07 Dec 1964	04 May 1965
	06 Dec 1965	25 Jul 1966
	NUC RVNGC	26 Dec 1965
28 Dec 1965		31 Dec 1965
02 Jan 1966		04 Jan 1966
09 Jan 1966		
15 Jan 1966		19 Jan 1966
25 Feb 1966		26 Feb 1966
28 Feb 1966		05 Mar 1966
01 Apr 1966		02 Apr 1966
25 May 1966		
24 Jun 1966		
27 Jun 1966		29 Jun 1966
28 Feb 1967		
07 Mar 1967		
11 Mar 1967		

**Unit Awards Received—Continued**

<i>Unit Award</i>	<i>Inclusive Dates Covering Unit Award</i>	
VNSM	13 Mar 1967	
	16 Mar 1967	
	20 Mar 1967	21 Mar 1967
	29 Apr 1967	01 May 1967
	16 May 1967	18 May 1967
	17 Dec 1965	23 Jan 1966
	11 Feb 1966	06 Mar 1966
	21 Mar 1966	10 Apr 1966
	27 Apr 1966	09 Jul 1966
	25 Feb 1967	21 Mar 1967
	17 Apr 1967	07 May 1967
	01 Jun 1967	18 Jun 1967
	27 Jun 1967	31 Jul 1967
	26 Feb 1967	30 Jul 1967
	01 Jul 1965	31 Dec 1966
PUC NAVE		



A flight of squadron A-1H Skyraiders during their deployment aboard Hancock (CVA 19) in 1965.

## SECOND VA-215

### Lineage

Established as Attack Squadron TWO HUNDRED FIFTEEN (VA-215) on 1 March 1968.

Disestablished on 30 September 1977. The second squadron to be assigned the VA-215 designation.

### Squadron Insignia and Nickname

The squadron's insignia was not submitted to CNO for approval. The insignia used by VA-215 incorporated a section of the first VA-215's insignia. Colors for this insignia were: a white background outlined by two rows of alternating green and white squares outlined in black; the stylized owl's head was silver with black markings, green eyes, and green plumage and wings, outlined in black; white scroll outlined in black with green lettering and the nickname, Barn Owls, in black.



The squadron's insignia used elements from the first VA-215 insignia and also used the name Barn Owls.

Nickname: Barn Owls, 1968–1977

### Chronology of Significant Events

**1 Mar 1968:** Following establishment, the squadron remained under the operational control of VA-122 during its training in the A-7 Corsair II.

**14 Jan 1969:** The squadron was embarked in *Enterprise* (CVAN 65), conducting operational training in Hawaiian waters prior to deployment when a major fire occurred on the flight deck of the carrier. Several squadron personnel were presented with citations from the Secretary of the Navy and the Commanding Officer of *Enterprise* for heroism during the fire.

**16 Apr 1969:** *Enterprise*, with VA-215 embarked, departed Yankee Station enroute to Korean waters in response to the downing of a Navy EC-121 aircraft by the North Koreans on 15 April. The squadron operated in the Sea of Japan and the Yellow Sea until 11 May.

**Dec 1972:** The squadron participated in Linebacker II operations, concentrated air strikes against North Vietnam.

**Feb 1973:** Following the cease fire with North Vietnam, the squadron flew combat missions in Laos until a cease fire was signed with that country on 22 February 1973.

**Nov 1973:** *Oriskany* (CVA 34), with VA-215 embarked, departed from operations in the South China Sea to relieve *Hancock* (CVA 19) on station in the Arabian Sea due to the unsettled conditions following the Yom Kippur War in the Middle East.

**Oct 1976–Apr 1977:** This was the twilight cruise of the *Roosevelt*, CVW-19 and VA-215.

### Home Port Assignments

Location	Assignment Date
NAS Lemoore	01 Mar 1968

### Commanding Officers

	Date Assumed Command
CDR George E. LeBlanc, Jr.	01 Mar 1968
CDR D. L. McConnell	08 May 1969
CDR W. H. Beck	Apr 1970
CDR Paul E. Phillips	19 Mar 1971
CDR James F. Crummer	20 Mar 1972
CDR Douglas E. French	04 May 1973
CDR Riley D. Mixson	26 Jul 1974
CDR John J. Schultz	31 Oct 1975
CDR Gary L. Harter	01 Dec 1976

### Aircraft Assignment

Type of Aircraft	Date Type First Received
A-7B	Jul 1968

### Major Overseas Deployments

Date of Departure	Date of Return	Air Wing	Carrier	Type of Aircraft	Area of Operation
06 Jan 1969	02 Jul 1969	CVW-9	CVAN 65	A-7B	WestPac/Vietnam
02 Jan 1970	27 Jul 1970	CVW-6	CVA 42	A-7B	Med
14 May 1971	18 Dec 1971	CVW-19	CVA 34	A-7B	WestPac/Vietnam
05 Jun 1972	30 Mar 1973	CVW-19	CVA 34	A-7B	WestPac/Vietnam
18 Oct 1973	05 Jun 1974	CVW-19	CVA 34	A-7B	WestPac/IO
16 Sep 1975	03 Mar 1976	CVW-19	CV 34	A-7B	WestPac
04 Oct 1976	21 Apr 1977	CVW-19	CV 42	A-7B	Med

**Air Wing Assignments**

<i>Air Wing</i>	<i>Tail Code</i>	<i>Assignment Date</i>
CVW-9	NG	Sep 1968
CVW-6	AE	Jul 1969
CVW-19	NM	10 Dec 1970

**Unit Awards Received**

<i>Unit Award</i>	<i>Inclusive Dates Covering Unit Award</i>	
AFEM	20 Apr 1969	11 May 1969
VNSM	30 Mar 1969	18 Apr 1969
	22 May 1969	24 May 1969
	29 May 1969	17 Jun 1969

**Unit Awards Received—Continued**

<i>Unit Award</i>	<i>Inclusive Dates Covering Unit Award</i>	
	15 Jun 1971	10 Jul 1971
	24 Jul 1971	07 Aug 1971
	03 Sep 1971	27 Sep 1971
	29 Oct 1971	21 Nov 1971
	26 Jun 1972	23 Jul 1972
	16 Aug 1972	01 Sep 1972
	11 Sep 1972	28 Sep 1972
	08 Oct 1972	31 Oct 1972
	24 Nov 1972	18 Dec 1972
	27 Dec 1972	31 Jan 1973
	10 Feb 1973	06 Mar 1973
MUC	28 Jun 1972	06 Mar 1973



*A formation of squadron A-7B Corsair IIs in 1972.*

## VA-216

### Lineage

Established as Attack Squadron TWO HUNDRED SIXTEEN (VA-216) on 30 March 1955.

Disestablished on 1 August 1970. The first squadron to be assigned the VA-216 designation.



*The Black Diamond insignia.*

### Squadron Insignia and Nickname

The squadron's insignia was approved by CNO on 28 March 1956. Colors for the insignia were black and white. The background was black with a white and black border; the shield and weapons were white with

black markings; the scroll was white outlined in black with black lettering.

Nickname: Black Diamonds, 1956–1970.

### Chronology of Significant Events

**Sep 1958:** VA-216, embarked in *Bennington* (CVA 20), operated in the Formosa Straits during the Chinese Communist shelling of Quemoy and Matsu.

**1 Jul 1959:** A reorganization by the Commander Naval Air Force, Pacific directed VA-216 and VA-192 to swap aircraft and all personnel. Commander Baumgaertel, the commanding officer of VA-192, became the commanding officer of VA-216 and all other personnel assigned to VA-192 were reassigned to VA-216. The FJ-4Bs that had been assigned to VA-192 were transferred to VA-216. This exchange was similar to a redesignation, but for reasons that are not on record, it was officially directed as an "exchange" rather than as a "redesignation."

**Mar 1961:** VA-216, embarked in *Lexington* (CVA 16), was ordered to operate off the coast of Thailand as a result of the deteriorating position of Laotian government forces against the Pathet Lao. Units of *Lexington's* air group flew reconnaissance missions over Laos.

**Apr 1962:** VA-216, embarked in *Hancock* (CVA 19), operated off the coast of South Vietnam during the arrival of the first USMC advisor unit in the Republic of Vietnam.

**May 1962:** The squadron, along with other CVG-21 units embarked in *Hancock*, were prepared to support a U.S. Marine Corps unit that landed in Bangkok and moved by air to Udorn. The Marine landing was at the request of the Thai government because of its concerns surrounding the success of Pathet Lao forces along the Thai-Laotian border.

**Sep 1963:** VA-216, embarked in *Hancock*, operated off the coast of Taiwan due to increased tensions between the People's Republic of China and the Republic of China.

**Nov 1963:** Embarked in *Hancock*, the squadron operated off the coast of South Vietnam following the coup that overthrew President Diem.

**29 Dec 1964–May 1965:** VA-216 participated in Yankee Team operations, armed reconnaissance flights over Laos, and Barrel Roll operations, armed reconnaissance and strike missions in eastern Laos covering the infiltration routes used by the Communists.

**7 Feb 1965:** VA-216 participated in Flaming Dart I operations, striking the Dong Hoi Barracks. These reprisal attacks against targets in North Vietnam were in response to the shelling of an American advisors compound at Pleiku by the Viet Cong.

**11 Feb 1965:** The squadron participated in Flaming Dart II operations, reprisal attacks against the barracks at Chanh Hoa, North Vietnam.

**Mar–May 1965:** VA-216's Skyhawks participated in the Rolling Thunder campaign, strikes against designated military targets in North Vietnam.

**Mar 1966:** Squadron aircraft participated in Operation Jackstay, providing close air support for the amphibious operations that cleared the Rung Sat zone, the river channels, southeast of Saigon.

**1 May 1966:** Lieutenant C. O. Tolbert was awarded the Silver Star for his actions during a combat mission over North Vietnam involving the Xom Dom Dien supply area and the sighting of a SAM missile battery which was destroyed in a later mission.

**7 Jul 1966:** The squadron's commanding officer, Commander C. Birdwell, was awarded the Silver Star for his actions in a strike against the Haiphong POL storage area.

**Jun 1970:** VA-216, embarked in *Forrestal* (CVA 59), operated in the Eastern Mediterranean after American hostages were taken by the Popular Front for the Liberation of Palestine in Amman, Jordan. The squadron, along with other units of CVW-17, were available also for air support during the evacuation of Americans from Jordan.



*A formation of squadron AD-4NA Skyraiders, July 1956 (Courtesy Robert Lawson Collection).*

### Home Port Assignments

<i>Location</i>	<i>Assignment Date</i>
NAS Moffett Field	30 Mar 1955
NAS Lemoore	Sep 1961
NAS Alameda	01 Aug 1968

### Commanding Officers—Continue

	<i>Date Assumed Command</i>
CDR James J. Tyson	10 Oct 1967
CDR James B. Busey IV	17 Dec 1968
CDR Roger A. Massey, Jr.	19 Sep 1969

### Commanding Officers

	<i>Date Assumed Command</i>
CDR Frank W. Ault	30 Mar 1955
CDR Hope Strong, Jr.	Sep 1956
CDR W. E. Payne, Jr.	13 Feb 1959
CDR L. F. Baumgaertel	01 Jul 1959
CDR M. E. Stewart	09 Oct 1959
CDR T. M. Smyer	05 Jul 1961
CDR R. W. Gait (acting)	02 Dec 1961
CDR G. W. Bailey	06 Jan 1962
CDR J. R. Anderson	31 Dec 1962
CDR J. W. Miller	10 Nov 1963
CDR R. E. Schwoeffermann	07 Nov 1964
CDR Carl Birdwell, Jr.	1965
CDR Robert S. Moore	21 Oct 1966

### Aircraft Assignment

<i>Type of Aircraft</i>	<i>Date Type First Received</i>
AD-4	Apr 1955
AD-4NA	Apr 1955
AD-5	May 1955
AD-4B	Jul 1955
AD-7	Oct 1956
AD-6	Jul 1958
A4D-2	16 Feb 1959
FJ-4B	01 Jul 1959
A4D-2N/A-4C*	04 Sep 1962
A-4B	Aug 1966
A-4C	1968
A-4E	13 Jun 1969

\* The A4D-2N designation was changed to A-4C in 1962.



**Major Overseas Deployments**

<i>Date of Departure</i>	<i>Date of Return</i>	<i>Air Wing</i>	<i>Carrier</i>	<i>Type of Aircraft</i>	<i>Area of Operation</i>
19 Mar 1956	13 Sep 1956	ATG-4	CVA 10	AD-4B/NA	WestPac
06 Jan 1958	02 Jul 1958	ATG-4	CVA 12	AD-7	WestPac
21 Aug 1958	12 Jan 1959	ATG-4	CVA 20	AD-6	WestPac
29 Oct 1960	06 Jun 1961	CVG-21	CVA 16	FJ-4B	WestPac
02 Feb 1962	24 Aug 1962	CVG-21	CVA 19	FJ-4B	WestPac
07 Jun 1963	16 Dec 1963	CVG-21	CVA 19	A-4C	WestPac
21 Oct 1964	29 May 1965	CVW-21	CVA 19	A-4C	WestPac/Vietnam
10 Nov 1965	01 Aug 1966	CVW-21	CVA 19	A-4C	WestPac/Vietnam
02 May 1967	06 Dec 1967	CVW-3	CVA 60	A-4B	Med
07 Sep 1968	18 Apr 1969	CVW-15	CVA 43	A-4C	WestPac/Vietnam
02 Dec 1969	08 Jul 1970	CVW-17	CVA 59	A-4E	Med



Two squadron FJ-4B Fury aircraft on Hancock's (CVA 19) flight deck during her deployment to WestPac in 1962.

**Air Wing Assignments**

<i>Air Wing</i>	<i>Tail Code</i>	<i>Assignment Date</i>
ATG-4	Z*/ND†	30 Mar 1955
CVG-21	NP	01 Jul 1959‡
COMFAIRALAMEDA		01 Sep 1966
CVW-3	AC	01 Feb 1967
COMFAIRALAMEDA		09 Dec 1967
CVW-15	NL	1968§
CVW-17	AA	1969

\* The tail code Z for Air Task Group 4 (ATG-4) was assigned on 24 July 1956.

† The tail code was changed from Z to ND in 1957. The effective date for this change was most likely the beginning of FY 58 (1 July 1957).

‡ ATG-4 was disestablished on 19 January 1959. VA-216 was assigned to CVG-21 on 1 July 1959 but was not an active part of the Air Group until its return from deployment in December 1959.

§ VA-216 probably joined CVW-15 upon the air wing's return from its deployment in April 1968.

**Unit Awards Received**

<i>Unit Award</i>	<i>Inclusive Dates Covering Unit Award</i>	
NAVE	01 Jul 1957	30 Jun 1958
AFEM	15 Dec 1960	24 Dec 1960
	01 Jan 1961	08 Jan 1961
	10 Mar 1962	14 Mar 1962
	14 Apr 1962	16 Apr 1962
	16 May 1962	18 May 1962
	04 Nov 1963	10 Nov 1963
	07 Dec 1964	04 May 1965
NUC	06 Dec 1965	25 Jul 1966
	10 Oct 1968	31 Mar 1969
RVNGC	26 Dec 1965	
	28 Dec 1965	31 Dec 1965
	02 Jan 1966	04 Jan 1966
	09 Jan 1966	
	15 Jan 1966	19 Jan 1966
	25 Feb 1966	26 Feb 1966
	28 Feb 1966	05 Mar 1966
	01 Apr 1966	02 Apr 1966

**Unit Awards Received—Continued**

<i>Unit Award</i>	<i>Inclusive Dates Covering Unit Award</i>	
	25 May 1966	
	24 Jun 1966	
	27 Jun 1966	29 Jun 1966
	15 Oct 1968	
	17 Oct 1968	18 Oct 1968
	21 Oct 1968	
	25 Oct 1968	27 Oct 1968
	14 Nov 1968	16 Nov 1968
	23 Nov 1968	
	25 Nov 1968	
	01 Dec 1968	02 Dec 1968
	04 Dec 1968	05 Dec 1968
	30 Dec 1968	
	01 Jan 1969	03 Jan 1969
	05 Jan 1969	

**Unit Awards Received—Continued**

<i>Unit Award</i>	<i>Inclusive Dates Covering Unit Award</i>	
	07 Jan 1969	10 Jan 1969
	14 Jan 1969	19 Jan 1969
	22 Jan 1969	
	24 Jan 1969	
	26 Jan 1969	
	09 Feb 1969	20 Feb 1969
	22 Feb 1969	03 Mar 1969
	19 Mar 1969	31 Mar 1969
VNSM	17 Dec 1965	23 Jan 1966
	11 Feb 1966	06 Mar 1966
	21 Mar 1966	10 Apr 1966
	27 Apr 1966	09 Jul 1966
	29 Dec 1968	30 Jan 1969
	08 Feb 1969	03 Mar 1969
	19 Mar 1969	30 Mar 1969



*Two squadron A-4C Skyhawks in flight, circa 1964–1965.*

## VA-304

### Lineage

Established as Attack Squadron THREE HUNDRED FOUR (VA-304) on 1 July 1970.

Disestablished on 31 December 1994. The first squadron to be assigned the VA-304 designation.



The squadron's skull and phoenix insignia.

### Squadron Insignia and Nickname

The squadron's insignia was approved by CNO on 21 January 1971. Colors for the insignia were: a black background with a white border; the outline of the phoenix is red and the claws are black; white skull with shades of gray; and a black scroll with red lettering.

Nickname: Firebirds, 1970–1994.

### Chronology of Significant Events

**1 Jul 1970:** VA-304, a reserve squadron, established as part of a reorganization intended to increase the combat readiness of the Naval Air Reserve Force. Elements of reserve unit, VA-20G3, were used to form the newly established VA-304.

**May 1987:** VA-304 operated from the Canadian Forces Base at Edmonton, Alberta, while participating in exercise Rendezvous 87-Bold Warrior. The exercise was a mock full-scale battle between elements of the Canadian Armed Forces with VA-304 acting as an aggressor force.

**Aug 1988:** VA-304 was the first reserve squadron to receive and operate the A-6E Intruder.



A squadron A-4C Skyhawk, circa 1970 or 1971.

### Home Port Assignments

Location	Assignment Date
NAS Alameda	01 Jul 1970

### Commanding Officers

	Date Assumed Command
CDR John H. Thompson	01 Jul 1970
CDR Peter L. Hammes	01 Jul 1971
CDR Jerry V. Kirk	21 Jan 1973
CDR Raymond G. Blake	20 Jul 1974
CDR David M. Boaz	17 Jan 1976
CDR Matthew A. McCarthy	Jan 1978
CDR Frank J. Bender	20 Oct 1979
CDR R. F. Bush	Jun 1981
CDR D. B. Ashworth	Mar 1983
CDR Thomas W. Hearn	Sep 1984
CDR Donald K. Simmons	20 Apr 1986
CDR Daniel R. Kestly	26 Apr 1987
CDR Michael F. Dibello	16 Oct 1988
CDR John R. Hines, Jr.	20 May 1990
CDR Robert S. Mull, Jr.	16 Nov 1991
CDR William A. Roig	22 May 1993
CDR Craig C. Groom	25 Jun 1994



A squadron A-7A Corsair II at NAS Alameda, California, in 1975.

**Aircraft Assignment**

<i>Type of Aircraft</i>	<i>Date Type First Received</i>
A-4C	Jul 1970
A-7A	06 Aug 1971
A-7B	Sep 1977
A-7E	Sep 1986
KA-6D	22 Jul 1988
A-6E	05 Aug 1988

**Air Wing Assignments**

<i>Air Wing</i>	<i>Tail Code</i>	<i>Assignment Date</i>
CVWR-30	ND	01 Jul 1970

**Unit Awards Received**

<i>Unit Award</i>	<i>Inclusive Dates Covering Unit Award</i>	
MUC	01 Nov 1973	30 Nov 1975
NAVE	01 Jul 1974	30 Sep 1976



*Two squadron A-6 Intruders over the Golden Gate Bridge.*

## VA-776

### Lineage

Reserve Attack Squadron SEVEN HUNDRED SEVENTY SIX (VA-776) called to active duty on 27 January 1968\*.

Deactivated and returned to reserve status on 18 October 1968.

### Squadron Insignia and Nickname

The squadron's insignia was approved by CNO on 21 November 1963. Colors for the insignia were: a blue background outlined in gold; white cloud outlined in black; gold eagle with black markings; gray liberty bell with black markings and the cross bar holding the bell was brown with black markings; orange bombs and the scroll was gold with black lettering.

Nickname: unknown.



The squadron's liberty bell insignia.

\* Few records exist for reserve squadrons prior to 1970. They did not submit history reports until 1970.

### Chronology of Significant Events

27 Jan 1968: The President directed the activation of VA-776 following the capture of *Pueblo* (AGER 2) by a North Korean patrol boat on 23 January 1968.

### Home Port Assignments

Location	Assignment Date
NAS Los Alamitos	27 Jan 1968
NAS Lemoore	13 Jun 1968

### Commanding Officers

	Date Assumed Command
CDR Milton E. Johnson, Jr.	27 Jan 1968

### Aircraft Assignment

Type of Aircraft	Date Type First Received
A-4B	Feb 1968
TA-4F	Jun 1968
A-4E	Jun 1968

### Air Wing Assignments

Air Wing	Tail Code	Assignment Date
COMFAIRALAMEDA	NR*	27 Jan 1968

\* This tail code was also assigned two other activated reserve squadrons, VA-873 and VF-703.



A squadron A-4B Skyhawk (Courtesy Robert Lawson Collection).

## VA-831

### Lineage

Reserve Attack Squadron EIGHT HUNDRED THIRTY ONE (VA-831) called to active duty on 27 January 1968\*.

Deactivated and returned to reserve status on 18 October 1968.

### Squadron Insignia and Nickname

There is no record of an officially approved insignia. Nickname: unknown.

### Chronology of Significant Events

**27 Jan 1968:** The President directed the activation of VA-831 following the capture of *Pueblo* (AGER 2) by a North Korean patrol boat on 23 January 1968.

**1 Jul 1968:** The squadron was the first activated reserve unit on the east coast to be assigned to an operational air wing.

\* Few records exist for reserve squadrons prior to 1970. They did not submit history reports until 1970.

### Home Port Assignments

<i>Location</i>	<i>Assignment Date</i>
NAS New York	27 Jan 1968
NAS Cecil Field	30 May 1968

### Commanding Officers

	<i>Date Assumed Command</i>
CDR Raymond Ketcham	27 Jan 1968

### Aircraft Assignment

<i>Type of Aircraft</i>	<i>Date Type First Received</i>
A-4B	Jan 1968

### Air Wing Assignments

<i>Air Wing</i>	<i>Tail Code</i>	<i>Assignment Date</i>
COMFAIRJACKSONVILLE	MA*	1968
CVW-1	AB	01 Jul 1968

\* This tail code was also assigned two other activated reserve squadrons, VF-661 and VF-931.



A squadron A-4 Skyhawk, circa 1968 (Courtesy Duane Kasulka Collection).

## VA-873

### Lineage

Reserve Attack Squadron EIGHT HUNDRED SEVENTH THREE (VA-873) called to active duty on 27 January 1968\*.

Deactivated and returned to reserve status on 12 October 1968.

### Squadron Insignia and Nickname

The squadron's insignia was approved by CNO on 16 March 1964. Colors for the insignia were: a white and blue background outlined in black; the blue background section had five white stars and the white section had a gold outline of San Francisco's Golden Gate with two blue rows of waves beneath the bridge; separating the two sections was a stylized aircraft in black with a red flame coming from the tail; the scroll was white outlined in black with black lettering.



*The squadron's insignia used a stylized aircraft design with stars in the upper half and the Golden Gate Bridge in the lower part.*

Nickname: unknown.

\* Few records exist for reserve squadrons prior to 1970. They did not submit history reports until 1970.

### Chronology of Significant Events

27 Jan 1968: The President directed the activation of VA-873 following the capture of *Pueblo* (AGER 2) by a North Korean patrol boat on 23 January 1968.

### Home Port Assignments

Location	Assignment Date
NAS Alameda	27 Jan 1968

### Commanding Officers

	Date Assumed Command
CDR Glen W. Stinnett, Jr.	27 Jan 1968

### Aircraft Assignment

Type of Aircraft	Date	Type First Received
A-4B		27 Jan 1968
A-4C		May 1968

### Air Wing Assignments

Air Wing	Tail Code	Assignment date
COMFAIRALAMEDA	NR*	27 Jan 1968
CVW-2	NE	01 Jul 1968
COMFAIRALAMEDA		01 Oct 1968

\* This tail code was also assigned to two other activated reserve squadrons, VA-776 and VF-703.



*A squadron A-4 Skyhawk, circa 1968 (Courtesy Doug Olson Collection).*

# Heavy Attack Squadron Histories (VAH)

## VAH-8 to VAH-123

### VAH-8

#### Lineage

Established as Heavy Attack Squadron EIGHT (VAH-8) on 1 May 1957.

Disestablished on 17 January 1968. The first squadron to be assigned the VAH-8 designation.



The squadron's approved insignia.

#### Squadron Insignia and Nickname

The squadron's insignia was approved by CNO on 29 April 1958. Colors for the insignia were not available.

Nickname: Fireballers, 1959–1968.

#### Chronology of Significant Events

**13 Mar 1960:** All nine of the squadron's A3D-2 Skywarriors were launched from the deck of *Midway* (CVA 41), while deployed to WestPac, and flew a formation trans-Pacific flight of 4,800 miles to their home port of NAS Whidbey Island. Refueling stops were made at NAS Barbers Point and Alameda. The total flight time was 10.9 hours and the aircraft arrived at NAS Whidbey Island on 15 March.

**Mar-Apr 1961:** The squadron, while deployed aboard *Midway*, operated in the South China Sea due to the deteriorating position of Laotian government forces.

**13 Mar 1962:** During exercise Potshot, squadron A3Ds were launched from *Midway* carrying Marine paratroopers who were dropped on a target site at Camp Pendleton.

**12 Dec 1963:** The squadron's commanding officer, Commander C. E. Guthrie, was killed in an aircraft

accident. His aircraft, while returning to NAS Cubi Point from a training flight, crashed into Mount Silanguin. The crewmembers, Lieutenant Ray G. English and ATCS Russell J. Marshall were also killed in the accident.

**Apr 1965:** The squadron participated in its first combat operations. Bombing missions were performed against targets such as army camps and marshalling yards during the combat deployment. Air-to-air refueling sorties for attack and fighter aircraft were also flown.

**May-Jun 1966:** The squadron's A-3B aircraft left *Constellation* (CVA 64), in late May while in Hawaii, and flew to Cubi Point to await the arrival of *Constellation*. During the period prior to the carriers arrival in the Philippines, the squadron's aircraft flew operations in support of Yankee Team from *Ranger* (CVA 61) and *Enterprise* (CVAN 65). During the deployment, the squadron's primary mission was combat aerial refuelling in support of CVW-15 and other units flying missions in North Vietnam.

#### Home Port Assignments

Location	Assignment Date
NAS North Island	01 May 1957
NAS Whidbey Island	01 Jul 1957

#### Commanding Officers

	Date Assumed Command
CDR Halford Woodson (acting)	01 May 1957
CDR LeRoy B. Fraser	28 Jun 1957
CDR Halford Woodson	21 Jun 1958
CDR Frederick R. Fearnow	29 Jan 1959
CDR Cyrus F. Fitton	05 Feb 1960
CDR James T. Cockrill	1961
CDR Frank S. Haak	30 Mar 1962
CDR C. E. Guthrie	01 Mar 1963
CDR Archie B. Treadwell	12 Dec 1963
CDR Charles W. Cates	04 Dec 1964
CDR Ralph E. Neiger	03 Dec 1965
CDR Thomas P. Stewart	14 Dec 1966



**Aircraft Assignment**

<i>Type of Aircraft</i>	<i>Date Type First Received</i>
A3D-2/A-3B†	12 Aug 1957
F9F-8B*	28 Aug 1957
F3D-2*	01 Sep 1957

**Aircraft Assignment—Continued**

<i>Type of Aircraft</i>	<i>Date Type First Received</i>
KA-3B	May 1967

\* These aircraft were used for training flights during the latter part of 1957.

† The A3D-2 designation was changed to A-3B in 1962.

**Major Overseas Deployments**

<i>Date of Departure</i>	<i>Date of Return</i>	<i>Air Wing</i>	<i>Carrier</i>	<i>Type of Aircraft</i>	<i>Area of Operation</i>
14 Jul 1958	19 Dec 1958	CVG-21	CVA 16*	A3D-2	WestPac
16 Aug 1958	12 Mar 1959	CVG-2	CVA 41	A3D-2	WestPac
15 Aug 1959	25 Mar 1960	CVG-2	CVA 41	A3D-2	WestPac
16 Feb 1961	28 Sep 1961	CVG-2	CVA 41	A3D-2	WestPac
06 Apr 1962	20 Oct 1962	CVG-2	CVA 41	A3D-2	WestPac
08 Nov 1963	26 May 1964	CVW-2	CVA 41	A-3B	WestPac
06 Mar 1965	23 Nov 1965	CVW-2	CVA 41	A-3B	WestPac/Vietnam
12 May 1966	03 Dec 1966	CVW-15	CVA 64	A-3B	WestPac/Vietnam
29 Apr 1967	04 Dec 1967	CVW-14	CVA 64	KA-3B	WestPac/Vietnam

\* VAH-8 Det L was embarked in *Lexington* (CVA 16) during its deployment to WestPac, operating with four squadron aircraft.



Two squadron A3D-2 Skywarriors fly over Midway (CVA 41) in 1959.

### Air Wing Assignments

<i>Air Wing</i>	<i>Tail Code</i>	<i>Assignment Date</i>
COMHATWING-2*	NL/ZD†	01 May 1957
COMFAIRWHIDBEY		01 Jul 1959
CVG-2‡/CVW-2§	NE	02 Jul 1959
CVW-15	NL	15 Jan 1966
CVW-14	NK	01 Jan 1967

\* VAH-8 was assigned to Commander Heavy Attack Wing 2 and temporarily assigned to a Carrier Air Group during deployment.

† Each heavy attack squadron was assigned its own tail code. These tail codes were different from the ones assigned to the carrier air groups. VAH-8's tail code was changed from NL to ZD in 1957. The effective date for this change was most likely the beginning of FY 58 (1 July 1957).

‡ On 30 June 1959 COMHATWING-2 was disestablished and VAH-8 was administratively assigned to COMFAIRWHIDBEY. On 2 July 1959, CVG-2 was assigned as VAH-8's operational senior command. CVG-2 became VAH-8's administrative senior on 15 August 1959.

§ CVG-2 was redesignated CVW-2 when Carrier Air Groups (CVG) were redesignated Carrier Air Wings (CVW) on 20 December 1963.

### Unit Awards Received

<i>Unit Award</i>	<i>Inclusive Dates Covering Unit Award</i>	
NAVE	Mar 1964	30 Jun 1965
AFEM	06 Sep 1958	10 Sep 1958
	12 Sep 1958	29 Sep 1958
	12 Oct 1958	30 Oct 1958

### Unit Awards Received—Continued

<i>Unit Award</i>	<i>Inclusive Dates Covering Unit Award</i>	
NUC	11 Nov 1958	15 Nov 1958
	30 Nov 1958	12 Dec 1958
	24 Mar 1961	25 Mar 1961
	28 Mar 1961	07 Apr 1961
	08 Apr 1965	11 May 1965
	19 May 1965	28 Jun 1965
	16 Apr 1965	04 Nov 1965
	29 May 1966	24 Nov 1966
	18 May 1967	26 Nov 1967
	05 Oct 1965	
RVNGC	09 Oct 1965	
	21 Jun 1966	22 Jun 1966
VNSM	01 May 1967	01 Nov 1967
	22 Jul 1965	26 Aug 1965
	10 Sep 1965	09 Oct 1965
	18 Oct 1965	04 Nov 1965
	14 Jun 1966	13 Jul 1966
	27 Jul 1966	31 Aug 1966
	08 Sep 1966	01 Oct 1966
	08 Jun 1967	11 Jun 1967
	18 Jun 1967	25 Jul 1967
	01 Aug 1967	03 Sep 1967
25 Sep 1967	15 Oct 1967	
24 Oct 1967	12 Nov 1967	

## VAH-15

### Lineage

Established Heavy Attack Squadron FIFTEEN (VAH-15) on 15 January 1958.

Disestablished on 15 February 1959. The first squadron to be assigned the VAH-15 designation.

**FILL IT UP!**



*The squadron's stylized aircraft insignia. Note the refueling line connecting the two aircraft.*

but its primary mission was to provide aerial refueling to the Naval Air Force, Atlantic Fleet.

### Squadron Insignia and Nickname

There is no record of the squadron receiving CNO approval for its insignia. Colors for the insignia are unknown.

Nickname: unknown.

### Chronology of Significant Events

Jan 1958: VAH-15 was established with the designation heavy attack

### Home Port Assignments

<i>Location</i>	<i>Assignment Date</i>
NAS Norfolk	15 Jan 1958

### Commanding Officers

	<i>Date Assumed Command</i>
LCDR Alfred G. Trube, Jr. (acting)	Jan 1958
CDR Trazewell T. Shepard, Jr.	13 Jun 1958

### Aircraft Assignment

<i>Type of Aircraft</i>	<i>Date Type First Received</i>
AJ-2	Apr 1958
TV-2	Jul 1958

### Air Wing Assignments

<i>Air Wing</i>	<i>Tail Code</i>	<i>Assignment Date</i>
NALCOLANTUNIT	GP	1958



*A squadron AJ-2 Savage at NAS Glenview, Illinois, circa 1958.*

## VAH-16

### Lineage

Established as Heavy Attack Squadron SIXTEEN (VAH-16) on 15 January 1958.

Disestablished on 30 January 1959. The first squadron to be assigned the VAH-16 designation.

### Squadron Insignia and Nickname

The squadron's insignia was approved by CNO on 25 July 1958. Colors for the insignia were: a background of alternating white and blue quadrants outlined in blue;



The squadron's one and only insignia.

light blue lightning bolt outlined in gold; white sword blade with a gold handle; and a blue scroll outlined in gold with red lettering.

Nickname: unknown.

### Chronology of Significant Events

**1 Jul 1958:** The squadron's primary heavy attack high altitude bombing mission was changed to aerial refueling.

**13 Jun 1958:** The squadron established Detachment A in Hawaii and then relocated it to Agana, Guam, with four AJ-2 aircraft.

### Home Port Assignments

Location	Assignment Date
NAS North Island	15 Jan 1958

### Commanding Officers

	Date Assumed Command
CDR R. L. Ashcraft	1958

### Aircraft Assignment

Type of Aircraft	Date Type First Received
AJ-2	15 Jan 1958

### Major Overseas Deployments

Date of Departure	Date of Return	Air Wing	Carrier	Det*	Type of Aircraft	Area of Operation
09 Aug 1957	02 Apr 1958	ATG-3	CVA 33	J*	AJ-2	WestPac
06 Jan 1958	30 Jun 1958	ATG-4	CVA 12	K*	AJ-2	WestPac

\* The squadron only deployed detachments. The departure dates listed above are for the carrier and do not apply to VAH-16's detachments. VAH-16's detachments were not established until after 15 January 1958 and their departure dates are not known.

### Air Wing Assignments

Air Wing	Tail Code	Assignment Date
COMHATWING-2	ZH	15 Jan 1958



A squadron AJ-2 Savage refueling an F3H-2M Demon from VF-64, circa 1958.

## VAH-21

### *Lineage*

Established as Heavy Attack Squadron TWENTY ONE (VAH-21) on 1 September 1968.

Disestablished on 16 June 1969. The first squadron to be assigned the VAH-21 designation.

### *Squadron Insignia and Nickname*

The squadron's insignia request was disapproved by CNO because the insignia instruction restricted the use of cartoon designs. A new insignia request was not submitted prior to the squadron's disestablishment.

Nickname: unknown.



*Squadron personnel standing at attention during the establishment ceremony at NS Sangley Point, Philippines, in September 1968.*

### *Chronology of Significant Events*

**1 Sep 1968:** Heavy Attack Squadron 21 became the first squadron in the Navy with a night interdiction mission using new electronic surveillance equipment (multi-sensors). Its mission was to interdict logistics moving over land or sea.

**1 Sep 1968:** A detachment of VAH-21 was established at NAF Cam Ranh Bay, South Vietnam. The detachment at NAF Cam Ranh Bay had been a Naval Air Test Center Project TRIM Detachment (TRIM: Trails Roads Interdiction Multi-sensor) prior to becoming a VAH-21 detachment.

**16 Jun 1969:** With the disestablishment of VAH-21, its record included no loss of aircraft or any wounds suffered by its personnel during operations in Southeast Asia.

### *Home Port Assignments*

<i>Location</i>	<i>Assignment Date</i>
NS Sangley Point, Philippines	01 Sep 1968

### *Commanding Officers*

	<i>Date Assumed Command</i>
CDR A. E. Forsman	01 Sep 1968
CDR N. D. Dunnan	1968

### *Aircraft Assignment*

<i>Type of Aircraft</i>	<i>Date Type First Received</i>
AP-2H	Sep 1968

### *Air Wing Assignments*

<i>Air Wing</i>	<i>Tail Code</i>	<i>Assignment Date</i>
COMFAIRWESTPAC	SL	01 Sep 1968

### *Unit Awards Received*

<i>Unit Award</i>	<i>Inclusive Dates Covering Unit Award</i>	
MUC	14 Jan 1968	01 Dec 1968



*A squadron AP-2H Neptune at NAS Patuxent River, 1969 (Courtesy Robert Lawson Collection).*

## VAH-123

### Lineage

Established as Heavy Attack Training Unit, Pacific (HATUPAC) on 15 June 1957.

Redesignated Heavy Attack Squadron ONE HUNDRED TWENTY THREE (VAH-123) on 29 June 1959.

Disestablished on 1 February 1971. The first squadron to be assigned the VAH-123 designation.

### Squadron Insignia and Nickname



*The squadron's insignia following its modification in 1961 which added the motto Professionalism is our Business.*

The unit's insignia was approved by CNO on 12 August 1959. Colors for the insignia are unknown. Following the unit's redesignation to VAH-123 the HATUPAC designation was removed from the scroll and replaced with VAH-123. In 1961 the design was modified to include an upper scroll with the motto Professionalism is Our Business.

Nickname: Professionals, 1961–1971.

### Chronology of Significant Events

**Jun 1957:** The unit was established to train personnel for the heavy attack mission, including the pilots, bombardier/navigation and aircrewmembers.

**25 Nov 1958:** Lieutenant Commander C. L. Chute became the first student to complete the unit's heavy attack training syllabus, through the solo stage, for the A3D-2 Skywarrior.

**Jan-Mar 1959:** The unit incorporated the maintenance training program into its syllabus, thereby providing a complete training program for all aspects of the heavy attack community's operational requirements.

**Aug 1966:** The squadron received its first A-6A Intruder in preparation for fleet replacement training in the new attack aircraft.

**1 Sep 1967:** VAH-123 was relieved of its mission of replacement training in the A-6 Intruder when VA-128 was established as a separate squadron from VAH-123 and assumed that mission.

**1 Feb 1971:** VAH-123 was disestablished and the mission of replacement training for the A-3/KA-3B was transferred to VAQ-130. Elements of VAH-123 were transferred to VAQ-130.



*A squadron P2V-3B at NAF Litchfield following its retirement from service (Courtesy Robert Lawson Collection).*

### Home Port Assignments

Location	Assignment Date
NAS North Island	15 Jun 1957
NAS Whidbey Island	01 Jul 1957

### Commanding Officers

	Date Assumed Command
LCDR R. H. Grant (acting)	15 Jun 1957
CDR Donald A. Miller	16 Jul 1957
CDR Frank J. Shaw	18 Jul 1958
CDR Norman K. McInnis	29 Dec 1959
CDR C. F. Fitton	20 Jun 1961
CDR R. E. Osterholm	15 Jan 1963
CDR L. E. Kirkemo	20 Feb 1964
CDR Edward C. Fritsch	05 Jan 1965
CDR John L. Underwood	14 Jan 1966
CDR John P. Sundberg	20 Jan 1967
CDR Horace B. Chambers	01 Dec 1967
CDR Donald K. Forbes	07 Jan 1969
CDR James E. Service	1970



*A squadron A-3 Skywarrior preparing to launch from Constellation (CVA 64) in March 1968.*

**Aircraft Assignment**

<i>Type of Aircraft</i>	<i>Date Type First Received</i>
P2V-3B	Jul 1957
F3D-2	Jul 1957
F9F-8B	01 May 1958
A3D-2/A-3B*	01 Aug 1958
F9F-8T	11 Feb 1958
A3D-1/A-3A*	Jul 1959
A3D-2P	04 Dec 1959

**Aircraft Assignment—Continued**

<i>Type of Aircraft</i>	<i>Date Type First Received</i>
A3D-2T/TA-3B*	21 Dec 1959
A3D-2Q	04 Aug 1960
A3D-1Q	12 Aug 1960
A-6A	17 Aug 1966
KA-3B	May 1967

\* The A3D-2, A3D-1 and A3D-2T designations were changed to A-3B, A-3A and TA-3B in 1962.



*A squadron A-6A Intruder, most likely at NAS Whidbey Island, Washington.*

**Air Wing Assignments**

<i>Air Wing</i>	<i>Tail Code</i>	<i>Assignment Date</i>
HATWING-2	ZG*	15 Jun 1957
RCVG-12/RCVW-12†	NJ‡	29 Jun 1958

\* The tail code ZG was assigned to Heavy Attack Training Unit, Pacific.

† Replacement Carrier Air Group 12 (RCVG-12) was redesignated RCVW-12 when Carrier Air Groups (CVG) were redesignated Carrier Air Wings (CVW) on 20 December 1963.

‡ RCVW-12 was disestablished on 1 June 1970 but VAH-123 continued to use the NJ tail code that had been assigned to RCVW-12.



*A squadron A-3 Skywarrior being placed on display for the squadron's disestablishment ceremony at NAS Whidbey Island, Washington, 1971.*

# Tactical Aerial Refueling Squadron Histories (VAK)

## VAK-208 to VAK-308

### VAK-208

#### Lineage

Established as Tactical Electronic Warfare Squadron TWO HUNDRED EIGHT (VAQ-208) on 31 July 1970.

Redesignated Aerial Refueling Squadron TWO HUNDRED EIGHT (VAK-208) on 1 October 1979.

Disestablished 30 September 1989. The first and only squadron to be assigned the VAK-208 designation.

#### Squadron Insignia and Nickname

The squadron's first insignia was approved by CNO on 6 May 1971. Colors for the insignia were: a yellow background outlined in red with a red scroll and black lettering; blue stylized tail code letters; brown eagle with white markings, orange beak and claws outlined in black, and a red eye; and red lightning bolts.



The squadron's first insignia used the eagle and a stylized AF tail code in its design.



The second insignia used by the squadron depicted the whale, reflecting the nickname of the aircraft flown by the squadron, the A-3.

Following the squadron's redesignation a new insignia was approved by CNO on 10 October 1980. Colors for this insignia were: a yellow background outlined in black; red scroll with white lettering; black latitude and longitudinal lines; alternating white and red compass star outlined in black; red directional letters; and a blue whale with black markings and a white eye and teeth.

Nickname: Jockeys, 1970–1989.

#### Chronology of Significant Events

**31 Jul 1970:** The squadron was established as part of a reorganization intended to increase the combat readiness of the Naval Air Reserve Force. It was to provide tanking, pathfinding and COD service to the Atlantic and Pacific Fleets and other units around the world.

**Mar 1971:** The squadron's first operational mission was conducted when it provided tanker support for CVWR-20 aircraft embarked in *Independence* (CVA 62) for a training exercise.

**Aug 1971:** The squadron conducted its two weeks of active duty training embarked in *John F. Kennedy* (CVA 67) as part of CVWR-20. This was the first complete Reserve Carrier Air Wing deployment aboard a carrier.

**Oct 1971:** The squadron conducted its first overseas operational assignment by providing tanker service across the Atlantic for RA-5C Vigilantes returning from a Mediterranean cruise.

**Jan 1972:** Squadron aircraft provided COD services for *Constellation* (CVA 64) on Yankee Station and *Enterprise* (CVAN 65) in the Indian Ocean.

**Sep 1972:** Squadron aircraft provided COD services for *Kennedy* while she was operating in the North Sea. The squadron aircraft operated out of NAF Mildenhall, England, during this evolution.

**Apr 1973:** Squadron aircraft provided support for Yellow Aspirin, a CNO mission to Kuwait to review the defense capabilities of that country.

**Oct 1973:** Squadron aircraft provide COD and refueling support during NATO Operation Swift Move for the air wing embarked in *Kennedy*, operating in the North Atlantic.

**16–30 Oct 1973:** During the Yon Kippur War in the Middle East, squadron aircraft provided support for Operation Nickle Grass, the transatlantic flight of A-4 Skyhawks to Israel.

**Jul–Aug 1974:** During civil unrest and the Turkish invasion of Cyprus, squadron aircraft provided tanker and logistic support for *Forrestal* (CVA 59) and *Independence* (CV 62) operating in the area of Cyprus during the crisis.

**Sep 1976:** Squadron aircraft provided support for the NATO Exercise Teamwork conducted in the North Atlantic.



**Sep 1978:** Squadron aircraft provided support for the NATO Exercise Northern Wedding conducted in the North Atlantic. Squadron aircraft operated out of NAF Mildenhall during this exercise.

**1 Oct 1979:** The squadron was redesignated Aerial Refueling Squadron 208 (VAK-208) and the mission of the squadron changed to primarily tanker service. The electronic warfare capability was removed from its mission.

**May–Jun 1980:** Squadron aircraft provided support for the French naval Exercise Suroit-80 in Landivisiau, France.

**Sep 1980:** Squadron aircraft provided support for the NATO Exercise Teamwork 80 held in the North Atlantic.

**Sep 1982:** Squadron aircraft provided support for Exercise Agile Falcon held in the North Atlantic.

**Sep–Oct 1984:** Squadron aircraft provided tanker/pathfinding support for NATO Exercise Display Determination–84.

**Home Port Assignments**

<i>Location</i>	<i>Assignment Date</i>
NAS Alameda	31 Jul 1970

**Commanding Officers**

	<i>Date Assumed Command</i>
AMSC L.V. Lambert (Petty Officer in Charge)	31 Jul 1970
LCDR J. F. Jefferson (Officer in Charge)	20 Nov 1970
CDR Thomas E. Frey	02 Jul 1971
CDR Tad H. Bingham	08 Jul 1973

**Commanding Officers—Continued**

	<i>Date Assumed Command</i>
CDR Earl B. Wynn, Jr.	06 Dec 1975
LCDR Phillip L. Middleton	14 Oct 1978
CDR B. A. Dempsey	04 Oct 1980
CDR Howard W. Goodroe	07 Nov 1981
CDR David O. Mason	13 Nov 1982
CDR Donald L. Dostal	06 May 1984
CDR David E. Boyd	03 May 1986
CDR Alden F. Mullins, Jr.	07 Nov 1987
CDR Andrew J. Kisela, Jr.	1989

**Aircraft Assignment**

<i>Type of Aircraft</i>	<i>Date Type First Received</i>
KA-3B	20 Nov 1970

**Air Wing Assignments**

<i>Air Wing</i>	<i>Tail Code</i>	<i>Assignment Date</i>
CVWR-20	AF	31 Jul 1970

**Unit Awards Received**

<i>Unit Award</i>	<i>Inclusive Dates Covering Unit Award</i>	
MUC	21 Dec 1971	30 Sep 1974
	01 Oct 1986	30 Sep 1989
SLOC	28 Mar 1983	18 Apr 1983
NAVE	01 Jul 1974	30 Sep 1976
	01 Oct 1976	30 Sep 1978



*A squadron KA-3B aboard Eisenhower (CVN 69) in September 1985.*

## VAK-308

### Lineage

Established as Tactical Electronic Warfare Squadron THREE HUNDRED EIGHT (VAQ-308) on 2 May 1970.

Redesignated Aerial Refueling Squadron THREE HUNDRED EIGHT (VAK-308) on 1 October 1979.

Disestablished on 30 September 1988. The first squadron to be assigned the VAK-308 designation.

### Squadron Insignia and Nickname

The squadron's insignia was approved by CNO on 28 December 1971. Colors for the Griffin insignia



*The squadron's Griffin insignia.*

were: a blue background outlined in gold, blue scroll outlined in gold with gold lettering; gold lightning bolt; the griffin had markings of different shades of brown, its head was white with shades of gray and its left wing had different shades of gray, the beak and eye were yellow with black markings, the tongue and claws were red outlined in black; red diamond designs outlined in white.

On 6 October 1981 CNO approved a modification to the squadron's insignia that changed the designation on the scroll from VAQ-308 to VAK-308.

Nickname: Griffins, 1971–1988.

### Chronology of Significant Events

2 May 1970: The squadron was established as part of a reorganization intended to increase the combat readiness of the Naval Air Reserve Force. It was to provide tanking, pathfinding and logistic support services to the Atlantic and Pacific Fleets and other units around the world.

23 Sep 1971: The squadron conducted its first tanker/pathfinder service across the Atlantic.

29 Nov–4 Dec 1971: The squadron conducted its first tanker/pathfinder service across the Pacific.

Dec 1971–Jan 1972: Squadron aircraft provided COD service to the *Enterprise* (CVAN 65) while operating in the Bay of Bengal during the Indo-Pakistani War.

Sep 1972: Squadron aircraft provided COD services for *Kennedy* (CVA 67) while she was operating in the North Sea.

Apr–May 1973: Squadron aircraft provided tanker/pathfinder services for two Reserve F-8 squadrons enroute to operations in the Middle East.

Sep–Oct 1973: Squadron aircraft provided COD and tanker service to *Kennedy* operating in the North Atlantic during NATO exercise Operation Magic Sword/Swift Move.

October 1973: During the Yon Kippur War in the Middle East squadron aircraft provided tanker/pathfinder service for Operation Nickle Grass, the transatlantic flight of A-4 Skyhawks enroute to Israel.

Jul–Aug 1974: During civil unrest and the Turkish invasion of Cyprus squadron aircraft provided tanker and logistic support for *Forrestal* (CVA 59) and *Independence* (CV 62) operating in the area of Cyprus during the crisis.

Sep 1974: Squadron aircraft provided COD and tanker service to *Kennedy* operating in the North Atlantic during NATO exercise Operation Northern Merger.

Sep–Oct 1984: Squadron aircraft provided tanker/pathfinder service to squadrons involved in exercise Display Determination held in the Mediterranean.

Apr–May 1987: Squadron aircraft provided tanker service to units involved in exercise Dragon Hammer. The squadron's aircraft operated out of NAS Sigonella during this evolution.

Apr 1988: Squadron aircraft provided tanker service to units involved in exercise Dragon Hammer. The squadron's aircraft operated out of NAS Sigonella during this evolution.



*A squadron KA-3B Skywarrior at NAS Alameda, California, in 1973. Notice the squadron designation VAQ-308 on the extended speed brake.*

**Home Port Assignments**

<i>Location</i>	<i>Assignment Date</i>
NAS Alameda	02 May 1970

**Commanding Officers**

	<i>Date Assumed Command</i>
CDR Gregory B. Bambo, Jr.	02 May 1970
CDR Charles Jacob	16 Jul 1972
CDR Gregory L. Davison	16 Jun 1974
CDR Tad H. Bingham	06 Dec 1975
CDR Gerald F. Hicks	17 Dec 1977
CDR George L. Green	Jan 1980
CDR James T. Edwards	16 Jan 1982
CDR Dennis J. Kowalzyk	24 Jul 1983
CDR William C. Burgess	19 Jan 1985
CDR Daniel Kalashian	20 Jul 1986
CDR David D. Abelson	28 Jan 1988

**Aircraft Assignment**

<i>Type of Aircraft</i>	<i>Date Type First Received</i>
KA-3B	Sep 1970

**Air Wing Assignments**

<i>Air Wing</i>	<i>Tail Code</i>	<i>Assignment Date</i>
CVWR-30	ND	02 May 1970

**Unit Awards Received**

<i>Unit Award</i>	<i>Inclusive Dates Covering Unit Award</i>	
MUC	21 Dec 1971	30 Sep 1974



*A squadron KA-3B in flight, 1984.*

# Light Attack Squadron History (VAL)

## VAL-4

### Lineage

Established as Light Attack Squadron FOUR (VAL-4) on 3 January 1969.

Disestablished on 10 April 1972. The first squadron to be assigned the VAL-4 designation.

### Squadron Insignia and Nickname

The squadron's first insignia was approved by CNO on 7 March 1969. Colors for the Yellow Jacket insignia were: a red background outlined in black; a white scroll outlined in black with black lettering; black stylized aircraft with yellow contrails; the yellow jacket had silver wings with black markings, a brown body outlined in black, the head and stinger tail were yellow with black markings; the lightning bolt from the tail was black and the explosion was yellow outlined in black.



*The yellow jacket wasp was the squadron's first insignia design.*



*The squadron's second insignia, the Black Ponies, is the one that is best known.*

On 14 July 1971 CNO approved a modification to the squadron's insignia. Colors for the Pony insignia were: a red background outlined in black; a white scroll outlined in black with black lettering; the stylized aircraft were black with yellow contrails; the pony was black.

Nickname: Black Ponies, 1971–1972.

### Chronology of Significant Events

**Sep 1968:** VS-41 was assigned the responsibility of training personnel scheduled for assignment to VAL-4.

**Oct 1968:** VS-41 received its first OV-10A Broncos for training VAL-4 personnel.

**Jan 1969:** VAL-4 was established with the mission of conducting surveillance and offensive operations in support of river patrol craft, as well as providing air support for SEALs and combined U.S. Army, Navy and South Vietnamese operations.

**Mar 1969:** VAL-4 was permanently based at the Naval Support Activity Detachment Airfield, Binh Thuy, South Vietnam, for combat operations. The squadron had two detachments, Det A assigned to Vietnamese Air Force Base, Binh Thuy and Det B at the Vung Tau, Army Airfield.

**19 Apr 1969:** The squadron began its first combat operations, flying air support of the Naval River Forces in the Mekong Delta of South Vietnam. The missions included normal patrol, overhead air cover, scramble alert and gunfire/artillery spotting.

**Apr-May 1970:** VAL-4's OV-10A Broncos participated in combined South Vietnamese and U.S. Riverine Force operations designed to neutralize sanctuary bases in the Mekong River Corridor in support of U.S. and South Vietnamese strikes against enemy sanctuaries in Cambodia.



*An OV-10A Bronco taking off from Vung Tau, Republic of Vietnam, on a combat mission, June 1969.*

**1 Jul 1970:** With the completion of new facilities for VAL-4 on Vietnamese Air Force Base Binh Thuy and the consolidation of VAL-4's operating units, the squadron's Detachment B was disestablished.

**31 Mar 1972:** The squadron conducted its last combat mission prior to its disestablishment on 10 April 1972.

### Home Port Assignments

<i>Location</i>	<i>Assignment Date</i>
NAS North Island	03 Jan 1969
NSA Binh Thuy, South Vietnam	23 Mar 1969

### Commanding Officers

	<i>Date Assumed Command</i>
CDR Gilbert L. Winans	03 Jan 1969
CDR Martin S. Schuman	06 Sep 1969
CDR Verle W. Klein	06 Mar 1970
CDR Leonard M. Rausch	03 Sep 1970
CDR Robert W. Porter	03 Mar 1971



*A squadron OV-10A Bronco in flight, 1969.*

### Aircraft Assignment

<i>Type of Aircraft</i>	<i>Date Type First Received</i>
OV-10A	03 Jan 1969
YOV-10D	Jun 1971

### Air Wing Assignments

<i>Air Wing</i>	<i>Tail Code</i>	<i>Assignment Date</i>
VS-41	UM	Sep 1968
COMFAIRWESTPAC	UM	Mar 1969

### Unit Awards Received

<i>Unit Award</i>	<i>Inclusive Dates Covering Unit Award</i>	
NUC	01 Jun 1964	01 Jun 1968
	01 Apr 1971	31 Oct 1971
MUC	26 Mar 1969	03 Sep 1969
RVNGC	21 Nov 1968	21 Nov 1970

### Unit Awards Received for VAL-4 Detachment B

<i>Unit Award</i>	<i>Inclusive Dates Covering Unit Award</i>	
NUC	14 Jun 1969	12 Aug 1969
PUC	24 Jun 1969	28 Feb 1970



*Three squadron OV-10A Broncos on a combat mission over the Mekong Delta, circa 1971. Note the squadron's Black Ponies insignia on the tail.*

# Heavy Photographic Squadron Histories (VAP)

## VAP-61 to VAP-62

### VAP-61

#### Lineage

Established as Patrol Squadron SIXTY ONE (VP-61) on 20 January 1951.

Redesignated Photographic Squadron SIXTY ONE (VJ-61) on 5 March 1952.

Redesignated Heavy Photographic Squadron SIXTY ONE (VAP-61) in April 1956.

Redesignated Composite Photographic Reconnaissance Squadron SIXTY ONE (VCP-61) on 1 July 1959.

Redesignated Heavy Photographic Squadron SIXTY ONE (VAP-61) on 1 July 1961.

Disestablished on 1 July 1971. The first squadron to be assigned the VAP-61 designation.

#### Squadron Insignia and Nickname

The squadron's first insignia was approved by CNO on 2 October 1951. This insignia had been used by



*This insignia was used by a different squadron prior to its approval for use by VP-61. It continued in use following VP-61's redesignation to VJ-61, VAP-61 and then VCP-61.*

VC-61 before being approved for use by VP-61. Colors for the insignia were: a blue background; a gray and white goose with a pink foot, green eyes, yellow bill, and a red tongue; the pilot and gunner's uniforms were olive green with yellow life jackets, pink faces, brown gloves, boots were olive green and brown, red nose and green eyes; black and white pilot's helmet and red gunner's helmet; black gun with white highlights and a brown stock; gray camera with white sides, a black and white lens with a blue and white sight; the globe had blue water, yellow and white land areas and black longitude and latitude lines.

A new insignia was approved by CNO on 11 January 1961. Colors for this insignia were: a light sil-



*The squadron's second insignia was approved for use by the unit when it was designated VCP-61. The acronym in the scroll was for Photo Composite Squadron (VCP) 61.*

*When VCP-61 was redesignated VAP-61, for the second time, it retained the stylized aircraft and globe design and just changed the scroll designation from PHOTOCOMPRON-61 to VAP-61.*

ver-blue background outlined in a medium blue; light silver-blue scroll outlined in dark blue with dark blue lettering; silver stylized aircraft with silver viewing lines; the land masses on the globe were an olive tan, a white ocean and dark blue longitude and latitude lines. The scroll designation was changed to VAP-61 in 1962.

Nickname: World Recorders.

#### Chronology of Significant Events

**20 Jan 1951:** The squadron's mission was aerial photographic reconnaissance and cartographic mapping. It deployed detachments around the world.

**Mar 1951:** A squadron detachment was ordered to photograph the Mississippi Delta area and adjacent coastline.

**May 1951:** A squadron detachment was ordered to Alaska in connection with mapping Alaska for the U.S. Army Map Service.

**1 Jul 1959:** The squadron's mission was to provide aerial photographic intelligence for naval operations and cartographic mapping in the Pacific, providing detachments for deployment aboard carriers, as well as land facilities.

**May 1964:** Squadron detachments began flying photographic reconnaissance missions over Laos and South Vietnam as part of Yankee Team Operations. Missions were flown from carriers operating in the South China Sea.



*A squadron PB4Y-1P in 1951 (Courtesy Robert Lawson Collection).*

**2–5 Aug 1964:** Squadron detachments aboard carriers operating in the South China Sea provided photo reconnaissance support during the Tonkin Gulf Crisis involving North Vietnamese patrol boat attacks on American destroyers.

**1965:** Squadron detachments continued to operate from carriers in the South China Sea; providing photo reconnaissance support for Yankee Team Operations; as well as flying missions over North Vietnam, part of the Rolling Thunder Operations; and assisting in Market Time Operations, coastal and shipping surveillance along the coast of South Vietnam.

**7 Aug 1966:** The squadron flew its first night combat infrared reconnaissance mission over North Vietnam. This began the use of infrared devices on squadron aircraft for interdicting truck convoys at night.

**31 Jan 1970:** The squadron's participation in Yankee Team Operations came to an end after 68 months of providing day and night reconnaissance flights over hostile areas in Southeast Asia. Yankee Team missions were flown from carriers operating in the South China Sea as well as shore facilities in Southeast Asia.

**1 Jul 1971:** The squadron was disestablished. During its period of service the squadron conducted mapping and special photographic projects in the Mediterranean area, Alaska, Hawaii and numerous other Pacific Islands, Korea, Japan, Okinawa, Philippines, North and South Vietnam, Laos, Thailand, New Guinea, New Britain, Australia and numerous places in the continental United States.



*A squadron F8U-1P Crusader in flight, circa 1960 (Courtesy Robert Lawson Collection).*

**Home Port Assignments**

Location	Assignment Date
NAAS Miramar/NAS Miramar*	20 Jan 1951
NAS Agana	Jun 1956

\* NAAS Miramar was redesignated NAS Miramar on 1 April 1952.

**Commanding Officers**

	<i>Date Assumed Command</i>
CDR Jesse L. Pennell	20 Jan 1951
CDR John S. Harris	19 Jul 1952
CDR Herbert L. Salyer	Jun 1953
CDR David L. Soper	May 1954
CDR Gilbert B. Jansen, Jr.	Jun 1955
CDR Sy E. Mendenhall	Nov 1956

**Commanding Officers—Continued**

	<i>Date Assumed Command</i>
CDR Jerry F. McDaniel	Sep 1958
CDR Ralph W. Spuhler	Dec 1959
CDR Jonathan J. Crowder	16 Sep 1960
CDR Donald B. Brady	09 Nov 1961
CDR Robert E. Morris	07 Nov 1962
CDR Hal B. Stewart	24 Oct 1963
CDR D. A. Woodard	06 Nov 1964
CDR George H. Lee	16 Nov 1965
CDR Horace B. Chambers	19 Nov 1966
CDR Archibald S. Thompson	14 Nov 1967
CDR Arthur R. Day	01 Nov 1968
CDR William E. Pippin	10 Nov 1969
CDR Robert L. Skillen	30 Nov 1970



*A couple of squadron AJ-2P Savages in flight, March 1953.*



**Aircraft Assignment**

<i>Type of Aircraft</i>	<i>Date Type First Received</i>
PB4Y-1P/P4Y-1P*	Jan 1951
AJ-2P	14 Sep 1952
F8U-1P	Aug 1959
A3D-2P/RA-3B†	Sep 1959

**Aircraft Assignment—Continued**

<i>Type of Aircraft</i>	<i>Date Type First Received</i>
KA-3B	26 Dec 1963

\* PB4Y-1Ps were redesignated P4Y-1Ps in 1951.  
† The A3D-2P designation was changed to RA-3B in 1962.



*A squadron AJ-2P Savage over NAS Agana, Guam, April 1958.*

**Air Wing Assignments**

<i>Air Wing</i>	<i>Tail Code</i>	<i>Assignment Date</i>
FAW-14	EF/PB*	20 Jan 1951
COMFAIRSANDIEGO	PB	1955
COMHATWING-2	PB/SS†	Jul 1956
COMFAIRPHILIPPINES	SS	01 Jan 1959
COMFAIRSOWESTPAC	SS	1960

**Air Wing Assignments—Continued**

<i>Air Wing</i>	<i>Tail Code</i>	<i>Assignment Date</i>
COMFAIRWESTPAC	SS	15 Jan 1964

\* It is believed the squadron's tail code was changed from EF to PB in 1953.  
† The tail code was changed from PB to SS in 1957. The effective date for this change was most likely the beginning of FY 58 (1 July 1957).



*A squadron RA-3B Skywarrior at NAS Agana, Guam, surrounded by a display of aerial cameras used for cartographic and reconnaissance photography taken by the squadron, circa 1965 or 1966.*

**Unit Awards Received**

<i>Unit Award</i>	<i>Inclusive Dates Covering Unit Award</i>	
MUC	02 Jun 1968	28 Feb 1970
NUC	01 Jun 1964	01 Jun 1968
	02 Aug 1964	05 Aug 1964

**Unit Awards Received—Continued**

<i>Unit Award</i>	<i>Inclusive Dates Covering Unit Award</i>	
AFEM	22 May 1961	04 Jun 1961
	13 Apr 1969	15 Jun 1969



*A camouflaged squadron RA-3B Skywarrior on the flight line at Da Nang, Republic of Vietnam, 1969.*

## VAP-62

### Lineage

Established as Photographic Squadron SIXTY TWO (VJ-62) on 10 April 1952.

Redesignated Heavy Photographic Squadron SIXTY TWO (VAP-62) on 2 July 1956.

Disestablished on 15 October 1969. The first squadron to be assigned the VAP-62 designation.



*This was the only insignia officially approved for use by the squadron.*



*CNO disapproved the use of the cartoon tiger insignia as the official squadron logo.*

### Squadron Insignia and Nickname

The squadron's insignia was approved by CNO on 3 August 1953. Colors for the insignia were: a red background outlined in yellow; the film strip had gray frames with white borders; yellow wings; blue eye with a white iris and a white beam emanating from the eye.

The squadron's request for a new insignia was disapproved by CNO on 20 October 1960. The tiger insignia was disapproved because cartoon portrayals were no longer acceptable under the insignia guidelines.

Nickname: Tigers, 1960–1969.

### Chronology of Significant Events

**Apr 1952:** The squadron's mission was aerial photographic intelligence for naval operations, deploying detachments in the Atlantic Ocean, Mediterranean Sea and other areas as required.

**1 Sep–19 Dec 1952:** A squadron detachment was deployed to Dhahran Air Force Base in Saudi Arabia.

**29 Jul 1960:** During a landing aboard *Saratoga* (CVA 60), the squadron's commanding officer, Commander C. T. Frohne, and two other squadron crewmembers, were lost when the tailhook of their A3D-2P Skywarrior separated and the aircraft plunged off the deck into the sea.

**Oct 1966:** The squadron transferred a detachment of aircraft and personnel to VAP-61 to augment that squadron's operations in Vietnam.

**15 Oct 1969:** The squadron was disestablished. During its period of service the squadron conducted mapping and special photographic projects in Saudi Arabia, Turkey, Italy, Spain, various countries in northern Europe, Greenland, Iceland, Labrador, various Central American and Caribbean countries, Morocco, the Mediterranean and Atlantic Ocean areas and numerous places in the United States.



*A formation of squadron PB4Y-1Ps (P4Y-1P), 1953 (Courtesy Robert Lawson Collection).*

### Home Port Assignments

Location	Assignment Date
NAS Jacksonville	10 Apr 1952
NAAS Sanford	20 Oct 1952
NAS Norfolk	Jul 1955
NAS Jacksonville	15 Aug 1957



*A formation of squadron AJ-2P Savages over Sanford, Florida, in 1953.*

**Commanding Officers**

	<i>Date Assumed Command</i>
LCDR D. C. McNeil (acting)	10 Apr 1952
CDR J. Kennedy, Jr.	30 Apr 1952
CDR H. S. Klenk	Jun 1953
CDR J. A. Goodwin	Jul 1954
CDR E. B. Johnson, Jr.	Jan 1956
CDR Henry W. Drum	12 Jul 1957
CDR Charles W. Hollinshead	10 Nov 1958
CDR Charles T. Frohne	10 Nov 1959
CDR W. L. Berkey (acting)	Jul 1960

**Commanding Officers—Continued**

	<i>Date Assumed Command</i>
CDR John E. Cousins	09 Sep 1960
CDR Charles H. Boldt, Jr.	06 Oct 1961
CDR Robert F. Roemer	04 Sep 1962
CDR John D. Stuffiebeem	Jul 1963
CDR John P. Cullen	08 Aug 1964
CDR William E. Nowers	05 Jul 1965
CDR Harry F. Bryant	22 Apr 1966
CDR Frank S. Coleman	16 Jun 1967
CDR Burke E. Eakie	Jul 1968
CDR James E. Service	18 Jul 1969



*A squadron A3D-2P Skywarrior on the deck of Independence (CVA 62) after a successful landing, 1961.*

**Aircraft Assignment**

<i>Type of Aircraft</i>	<i>Date Type First Received</i>
P4Y-1P	May 1952
AJ-2P	Sep 1952
F7F-4N	May 1953
A3D-1P	14 Oct 1957
A3D-2P/RA-3B*	19 Oct 1959

\* The A3D-2P designation was changed to RA-3B in 1962.

**Air Wing Assignments**

<i>Air Wing</i>	<i>Tail Code</i>	<i>Assignment Date</i>
COMFAIRJACKSON-VILLE	TP	10 Apr 1952
COMFAIRNORFOLK	TP	Jul 1955
COMFAIRJACKSON-VILLE	TP/GB*	15 Aug 1957

\* The tail code was changed from TP to GB in 1957. The effective date for this change was most likely the beginning of FY 58 (1 July 1957).



*A squadron A3D-2P in flight, 1961.*

**Unit Awards Received**

<i>Unit Award</i>	<i>Inclusive Dates Covering Unit Award</i>	
NUC	18 Jan 1960	25 Oct 1962
AFEM	06 Jun 1964	13 Jul 1964



*A squadron A3D-2P Skywarrior on display at NS Mayport, Florida, in May 1961.*

# Strike Fighter Squadron Histories (VFA)

## VFA-15 to VFA-305

### VFA-15

#### Lineage

Established as Attack Squadron SIXTY SEVEN (VA-67) on 1 August 1968.

Redesignated Attack Squadron FIFTEEN (VA-15) on 2 June 1969.

Redesignated Strike Fighter Squadron FIFTEEN (VFA-15) on 1 October 1986. The first squadron to be assigned the VA-67 designation, the second to be assigned the VA-15 designation and the first to be assigned the VFA-15 designation.

#### Squadron Insignia and Nickname

The squadron does not have a CNO approval date for the use of the lion and missile insignia. This



*The squadron adopted the lion insignia used by the first VA-15. The designation in the scroll was changed to VFA-15 in 1986.*

insignia was approved by the CNO for use by the first squadron to be assigned the VA-15 designation. When VA-67 was redesignated VA-15 on 2 June 1969, it adopted the insignia that had been used by the first VA-15, which had been disestablished on 1 June 1969. Colors for the lion insignia are: background with red upper half and blue-green lower half, the insignia and scroll are outlined in white; blue scroll with white lettering; white waves; white rocket with black markings and yellow streaks emanating from the tail; yellow lion with black markings.

Nickname: Valions, 1969-present.

#### Chronology of Significant Events

**1 Aug 1968:** The squadron began training under VA-174 in preparation for operating the A-7 Corsair II.

**19 Oct 1973:** The squadron provided maintenance personnel for Operation Nickle Grass, the transatlantic flight of A-4 Skyhawks to Israel using *Franklin D. Roosevelt* (CVA 42) as an intermediate air field.

**Oct–Nov 1973:** The squadron, embarked in *Roosevelt*, operated in the vicinity of Crete in response to the Arab-Israeli war.

**Jun–Jul 1976:** Following the assassination of the American Ambassador to Lebanon on 13 June, *America* (CV 66), with VA-15 embarked, operated in the vicinity of Lebanon and flew support missions during the evacuation of non-combatants from that country.

**May 1981:** *Independence* (CV 62), with VA-15 embarked, transited the Suez Canal and maintained station in the eastern Mediterranean due to the crisis between Israel and Syria following Israeli raids against Syrian surface-to-air missile sites in Lebanon.

**25 Oct–1 Nov 1983:** In response to continued political strife and the need to protect and evacuate Americans from the island country of Grenada, VA-15 aircraft flew combat close air support and reconnaissance sorties in support of operation Urgent Fury, the landing of U.S. Marines and Army rangers on the island.

**4 Dec 1983:** In response to hostile fire against U.S. reconnaissance aircraft from Syrian positions in Lebanon, VA-15 aircraft participated in coordinated strikes against Syrian radar, communications and artillery positions overlooking the Multi-National Peacekeeping Forces. One of the squadron's A-7E Corsair IIs, flown by the Air Wing Commander, Command Edward Andrews, was lost when it was hit by a Syrian surface-to-air missile. Commander Andrews ejected, was rescued and returned to *Independence*.

**Dec 1985–Jun 1986:** The squadron returned from a six-month deployment to MCAS Iwakuni in the western Pacific. It was assigned to MAG-12, 1st Marine Air Wing during the deployment. This deployment was designed to test the enhanced interoperability between Marine and Naval Air Forces, with emphasis on close air support for Marine ground operations and the sharing of other techniques used by both communities.

**Home Port Assignments**

<i>Location</i>	<i>Assignment Date</i>
NAS Cecil Field	01 Aug 1968

**Commanding Officers**

	<i>Date Assumed Command</i>
CDR Lawrence C. Chambers	06 Nov 1968
CDR Robert B. Bristol	12 Feb 1970
CDR Donald D. Brown	30 Mar 1971
CDR Forrest A. Lees, Jr.	30 Mar 1972
CDR Richard C. McClary	21 Mar 1973
CDR Harry P. Kober, Jr.	24 May 1974
CDR Gordon E. Evans	30 Jul 1975
CDR Kelvin W. Huehn	02 Oct 1976
CDR Robert S. Smith	17 Dec 1977
CDR John J. Mazach	19 Apr 1979

**Commanding Officers—Continued**

	<i>Date Assumed Command</i>
CDR John J. Coonan	26 Jun 1980
CDR Michael B. Nordeen	24 Sep 1981
CDR Byron L. Duff	01 Nov 1982
CDR Leslie G. Kappel	01 Jun 1984
CDR Philip Craig Landon	08 Oct 1985
CDR John W. Curtin	08 Jan 1987
CDR Milton W. Smith	13 May 1988
CDR Brian M. Calhoun	29 Nov 1989

**Aircraft Assignment**

<i>Type of Aircraft</i>	<i>Date Type First Received</i>
A-7B	10 Mar 1969
A-7E	Aug 1975
F/A-18A	06 Jan 1987



*A squadron A-7E Corsair II taking off from the deck of Independence (CV 62) in 1982.*

**Major Overseas Deployments**

<i>Date of Departure</i>	<i>Date of Return</i>	<i>Air Wing</i>	<i>Carrier</i>	<i>Type of Aircraft</i>	<i>Area of Operation</i>
02 Jan 1970	27 Jul 1970	CVW-6	CVA 42	A-7B	Med
29 Jan 1971	23 Jul 1971	CVW-6	CVA 42	A-7B	Med
15 Feb 1972	08 Dec 1972	CVW-6	CVA 42	A-7B	Med
14 Sep 1973	17 Mar 1974	CVW-6	CVA 42	A-7B	Med
03 Jan 1975	16 Jul 1975	CVW-6	CV 42	A-7B	Med
15 Apr 1976	25 Oct 1976	CVW-6	CV 66	A-7E	Med
10 Jun 1977	19 Jul 1977	CVW-6	CV 66	A-7E	SoLant
29 Sep 1977	25 Apr 1978	CVW-6	CV 66	A-7E	Med

**Major Overseas Deployments**

<i>Date of Departure</i>	<i>Date of Return</i>	<i>Air Wing</i>	<i>Carrier</i>	<i>Type of Aircraft</i>	<i>Area of Operation</i>
28 Jun 1979	14 Dec 1979	CVW-6	CV 62	A-7E	Med
19 Nov 1980	10 Jun 1981	CVW-6	CV 62	A-7E	SoLant/IO/Med
07 Jun 1982	22 Dec 1982	CVW-6	CV 62	A-7E	Med
18 Oct 1983	11 Apr 1984	CVW-6	CV 62	A-7E	Carib/Med/NorLant
16 Oct 1984	19 Feb 1985	CVW-6	CV 62	A-7E	Med/IO
01 Dec 1985	13 Jun 1986	MAG-12	*	A-7E	WestPac
25 Aug 1988	11 Oct 1988	CVW-8	CVN 71	F/A-18A	NorLant
30 Dec 1988	30 Jun 1989	CVW-8	CVN 71	F/A-18A	Med
28 Dec 1990	28 Jun 1991	CVW-8	CVN 71	F/A-18A	Med/Red Sea/ Persian Gulf

\* The squadron forward deployed to MCAS Iwakuni, Japan, to provide close air support for Marine forces in WestPac. While deployed to WestPac the squadron also operated at NAF Kadena, Okinawa; NAS Cubi Point, Philippines and stations in Korea.

**Air Wing Assignments**

<i>Air Wing</i>	<i>Tail Code</i>	<i>Assignment Date</i>
COMFAIRJACKSON-VILLE		01 Aug 1968
CVW-6	AE	11 Mar 1969
COMLATWING 1		Apr 1985
MAG-12, 1st MAW*	AC*	Dec 1985
COMLATWING 1		Jun 1986
CVW-8	AJ	01 Sep 1987

\* VA-15 was assigned to MAG-12, 1st Marine Air Wing during its shore-based deployment to MCAS Iwakuni, Japan. While deployed with MAG-12 the squadron used the tail code AC on its aircraft.

**Unit Awards Received—Continued**

<i>Unit Award</i>	<i>Inclusive Dates Covering Unit Award</i>
	01 Jul 1976 - 31 Dec 1980
	01 Jan 1987 - 31 Dec 1988
NAVE	01 Oct 1977 - 30 Sep 1978
	01 Oct 1979 - 30 Sep 1980
	01 Jan 1983 - 31 Dec 1983
	01 Jan 1988 - 31 Dec 1988
NEM	07 Dec 1980 - 11 May 1981
	20 Aug 1982 - 05 Sep 1982
	01 Oct 1982 - 06 Dec 1982
AFEM	24 Oct 1983 - 02 Nov 1983
	16 Nov 1983 - 22 Dec 1983
	28 Dec 1983 - 03 Jan 1984
	15 Jan 1984 - 03 Feb 1984
	09 Feb 1984 - 02 Mar 1984
HSM	20 Jun 1976 - 27 Jul 1976

**Unit Awards Received**

<i>Unit Award</i>	<i>Inclusive Dates Covering Unit Award</i>
MUC	09 Mar 1972 - 01 Dec 1972



*A flight of squadron F/A-18A Hornets in 1990.*



## VFA-22

### Lineage

Established as Fighting Squadron SIXTY THREE (VF-63) on 27 July 1948.

Redesignated Attack Squadron SIXTY THREE (VA-63) in March 1956.

Redesignated Attack Squadron TWENTY TWO (VA-22) on 1 July 1959.

Redesignated Strike Fighter Squadron TWENTY TWO (VFA-22) on 4 May 1990. The first squadron to be assigned the VA-22, VA-63 and VFA-22 designation.

### Squadron Insignia and Nickname

The squadron's insignia was approved by CNO on 9 May 1949. The background is a heraldic bar sinister shield and with cumulus clouds. Overlaying the background is a gamecock ready to strike.



*This insignia has been used by the squadron since its CNO approval in 1949. The only modification was the addition of the scroll and the VA-22 designation, which changed to VFA-22 in 1990.*

Colors for the insignia are as follows: the gamecock and bar on the shield are red with black outlines; the beak and feet of the gamecock are gold and the background of the shield and clouds are white outlined in black. The squadron continued to use the insignia following its redesignations to VA-63, VA-22 and then VFA-22. VA-22

added a scroll at the bottom of the shield. The scroll has a white background outlined in black with red lettering. On 14 September 1990, CNO approved a modification to the insignia, changing the designation in the scroll to VFA-22.

Nickname: Fighting Redcocks, 1949-present.

### Chronology of Significant Events

**16 Sep 1950:** The squadron participated in its first combat action, providing close air support for the amphibious landings at Inchon, Korea.

**23 Jun 1952:** VF-63, along with other units from *Boxer* (CV 21), *Princeton* (CV 37), *Philippine Sea* (CV 47), *Bon Homme Richard* (CV 31), U.S. Air Force and Marine Corps squadrons, conducted a major offensive against hydro-electric targets in North Korea.

**6 Aug 1952:** While launching combat sorties a severe fire broke out on the hangar deck of *Boxer* following the explosion of an aircraft gasoline tank. Eight people were killed and one was missing, with several seriously injured. VF-63 did not suffer any casualties, however, three of the squadron's personnel were awarded Bronze Stars for their heroic and courageous action during the fire.

**Feb 1955:** The squadron, while deployed aboard *Essex* (CVA 9), provided air support during the evacuation of Chinese Nationalist from the Tachen Islands after the bombardment of the islands by the People's Republic of China.

**9 May 1958:** The squadron became the first fleet unit to receive the FJ-4B Buddy Tanker package and successfully demonstrated its refueling capability.

**Mar-Apr 1961:** The squadron, while deployed aboard *Midway* (CVA 41), operated in the South China Sea due to the crisis in Laos.

**6 Mar 1963:** The squadron formed Detachment Romeo consisting of four A-4B Skyhawks, six pilots



*Squadron personnel on the deck of Valley Forge (CV 45) in February 1951. A squadron F4U-4 Corsair is in the background.*

and forty-eight enlisted personnel. Its mission was to deploy aboard ASW carriers and provide them with a limited amount of air defense.

**19 Apr–3 Dec 1963:** VA-22 Detachment Romeo was deployed to the western Pacific aboard *Kearsarge* (CVS 33) and part of CVSG-53. During the deployment it participated in the recovery of space capsule Faith 7 and astronaut Major L. Gordon Cooper, USAF, following his 22 successful orbits around the earth.

**18 Dec 1963:** VA-22 Detachment Romeo was disestablished.

**Apr 1965:** The squadron participated in its first combat operations since the Korean War and on 20 April suffered its first aircraft loss. Lieutenant Phillip N. Butler's A-4C was hit by enemy antiaircraft fire while on a night armed reconnaissance mission over North Vietnam. He successfully ejected and became a prisoner of war.

**3 Jun 1965:** Lieutenant Raymond P. Ilg (later Vice Admiral) was shot down in his A-4C while on an armed road reconnaissance mission over northern Laos. He successfully ejected and, following three days of evading capture deep inside enemy territory, was rescued by a helicopter.

**22 Nov 1966:** Commander Henry D. Arnold, commanding officer of VA-22, received the Silver Star Medal for his actions during a strike against a Haiphong surface-to-air missile support facility.

**26 Jan 1968:** The *Ranger* (CVA 62), with VA-22 aboard, while operating on Yankee Station was ordered to the Sea of Japan following the capture of *Pueblo* (AGER 2) by the North Koreans on 23 January 1968. *Ranger* and VA-22 operated in the area until relieved on 5 March 1968.

**9 May 1972:** Operation Pocket Money, the mining of Haiphong harbor, was launched. Aircraft from VA-22, as well as the other attack squadrons deployed aboard *Coral Sea* (CVA 43), planned and executed the mining.

**Apr–Jul 1973:** The squadron flew missions in sup-

port of Operation End Sweep, the clearing of mines from North Vietnam's coastal waters.

**29 Apr 1975:** VA-22's aircraft provided air cover for Operation Frequent Wind, the evacuation of American citizens from Saigon. The last American helicopter to lift off the roof of the United States Embassy was escorted by an A-7E from the squadron.

**15 May 1975:** VA-22 aircraft, along with other elements from CVW-15 aboard *Coral Sea*, launched air strikes against the Cambodian mainland after the capture of the SS *Mayaguez* by Cambodian gunboats on 12 May. Squadron aircraft flew ten combat sorties and struck targets at Ream Airfield.

**27 Oct 1979:** Following the assassination of Park Chung Hee, President of the Republic of Korea, *Kitty Hawk* (CV 63) was ordered to operate off the coast of Korea.

**21 Nov 1979:** *Kitty Hawk*, along with VA-22 and the rest of CVW-15, departed Subic Bay, Philippines, enroute to the Arabian Sea as a response to the 4 November Iranian seizure of the American Embassy in Tehran and the taking of over 60 American hostages.

**6 Dec 1985:** A squadron aircraft fired an AGM-88 Harm missile while operating out of NWC China Lake. This was the first AGM-88 Harm missile fired by a West Coast Fleet squadron.

**Apr–Jul 1986:** In late April *Enterprise* (CVN 65), with VA-22 onboard, transited the Suez Canal from the Indian Ocean to the Mediterranean Sea to augment carrier forces there. Earlier in the month American strikes were flown against Libyan military targets as a response to Libya's continuing support of terrorist activity.

**18 Apr 1988:** VA-22 participated in retaliatory strikes against Iranian oil platforms, gunboats and other naval ships after *Samuel B. Roberts* (FFG 58) struck an Iranian mine on 14 April in international waters.

**Dec 1989:** The squadron participated in Operation Classic Resolve, providing support for the Philippine government during a coup d'etat attempt.



A formation of squadron F4U-4 Corsairs, May 1952 (Courtesy Robert Lawson Collection).



*A squadron A-7E Corsair II at NAS Lemoore, California, in 1975.*



*A squadron A-7E Corsair II in an unusual paint scheme, 1989.*

### **Home Port Assignments**

<i>Location</i>	<i>Assignment Date</i>
NAS Norfolk	27 Jul 1948
NAAS Oceana	20 Mar 1949
NAS Alameda	09 Aug 1950
NALF Santa Rosa	12 Jul 1951
NAS Alameda	25 Sep 1952
NAS Lemoore	28 Sep 1961



*A squadron F9F-5 Panther gets a wave-off from the Landing Signal Officer aboard Yorktown (CVA 10) during her cruise to WestPac, 1953–1954.*

**Commanding Officers**

	<i>Date Assumed Command</i>
LCDR Malcolm W. Cagle	27 Jul 1948
LCDR Thomas J. Ball	13 Feb 1950
LT L. W. S. Cummins (acting)	17 Aug 1951
LCDR Ward S. Miller	20 Aug 1951
LCDR Elmon A. Miller, Jr.	31 Oct 1952
CDR Robert H. Benson	Apr 1953
CDR Howard B. Eddy	Jul 1955
LCDR William C. Chapman	07 Jun 1957
CDR John H. Lobdell	20 Mar 1959
CDR Jack D. Kendall	31 Mar 1960
CDR W. T. Laws	10 Oct 1961
CDR E. W. Abbott	29 Oct 1962
CDR R. S. Smith	12 Sep 1963
CDR C. E. Dechow	02 Oct 1964
CDR E. H. Schorz (acting)	06 Oct 1964
CDR D. M. Wyand	20 Oct 1964
CDR E. H. Schorz	1965
CDR Henry D. Arnold	20 Oct 1966
CDR Jack K. Ashmore	07 Oct 1967
CDR Richard T. Gaskill	18 Oct 1968
CDR Henry C. Holt IV	16 Oct 1969
CDR James C. Thompson	22 Oct 1970
CDR Robert G. Ehrman	1971
CDR Leonard E. Giuliani	31 Aug 1972
CDR Gary A. Scoffield	28 Jul 1973
CDR John F. Calvert	08 Nov 1974
CDR Alan M. Dundon	27 Feb 1976
CDR Lee B. Cargill	22 Apr 1977
CDR John D. Grice	06 Jul 1978
CDR Jerry D. Palmer	25 Sep 1979
CDR John E. Vomastic	09 May 1981
CDR Russell C. York	Feb 1983
CDR Raymond A. Kellett	26 Jul 1984
CDR Richard J. Burns	01 Feb 1986
CDR William H. Roberson III	31 Jul 1987
CDR Dale M. Doorly	20 Jan 1989
CDR G. Robert Darwin	09 Aug 1990

**Aircraft Assignment**

<i>Type of Aircraft</i>	<i>Date Type First Received</i>
F8F-2	Jul 1948
F4U-4	Jan 1950
F9F-2*	14 Sep 1951
F9F-5*	Dec 1952
F9F-6	Apr 1954
F9F-8	Aug 1955
FJ-4B	30 Jul 1957
A4D-2/A-4B†	24 May 1960
A4D-2N/A-4C†	06 Oct 1961
A-4F	Jun 1968
TA-4F‡	Jun 1968
A-7E	04 Feb 1971
F/A-18C	06 Jul 1990

\* The squadron was scheduled to transition to the F9F-2 aircraft and received eight of the aircraft in September 1951, however, due to the severe lag in production of the aircraft and lack of critical spare parts, the squadron returned to flying the F4U-4 Corsair in the latter part of September 1951. It continued to fly the F4U-4 until November 1952 when it transitioned to jets. Initially it received F9F-2 aircraft in November 1952 and then switched to F9F-5 Panthers.

† In 1962 the Navy's aircraft designation system was changed and A4D-2 was redesignated A-4B and A4D-2N became A-4C.

‡ The TA-4Fs were tandem seat Skyhawks used for instrument training.



*A squadron FJ-4B Fury, circa 1958 (Courtesy Robert Lawson Collection).*



*A formation of squadron F9F-8 Cougars, 1957 (Courtesy Robert Lawson Collection)*

**Major Overseas Deployments**

<i>Date of Departure</i>	<i>Date of Return</i>	<i>Air Wing</i>	<i>Carrier</i>	<i>Type of Aircraft</i>	<i>Area of Operation</i>
27 Oct 1949	22 Nov 1949	CVG-6	CVB 42	F8F-2	NorLant
24 Aug 1950	11 Nov 1950	CVG-2	CV 21	F4U-4	WestPac/Korea
06 Dec 1950	*	CVG-2	CV 45	F4U-4	WestPac/Korea
*	09 Jun 1951	CVG-2	CV 47	F4U-4	WestPac/Korea
07 Feb 1952	25 Sep 1952	CVG-2	CV 21	F4U-4	WestPac/Korea
03 Aug 1953	03 Mar 1954	CVG-2	CVA 10	F9F-5	WestPac
03 Nov 1954	21 Jun 1955	CVG-2	CVA 9	F9F-6	WestPac
13 Nov 1956	20 May 1957	CVG-2	CVA 38	F9F-8	WestPac
16 Aug 1958	12 Mar 1959	CVG-2	CVA 41	FJ-4B	WestPac
15 Aug 1959	25 Mar 1960	CVG-2	CVA 41	FJ-4B	WestPac
16 Feb 1961	28 Sep 1961	CVG-2	CVA 41	A4D-2	WestPac
06 Apr 1962	20 Oct 1962	CVG-2	CVA 41	A4D-2N	WestPac
08 Nov 1963	26 May 1964	CVW-2	CVA 41	A-4C	WestPac
06 Mar 1965	23 Nov 1965	CVW-2	CVA 41	A-4C	WestPac/Vietnam
29 Jul 1966	23 Feb 1967	CVW-2	CVA 43	A-4C	WestPac/Vietnam
04 Nov 1967	25 May 1968	CVW-2	CVA 61	A-4C	WestPac/Vietnam
18 Mar 1969	29 Oct 1969	CVW-5	CVA 31	A-4F	WestPac/Vietnam
02 Apr 1970	12 Nov 1970	CVW-5	CVA 31	A-4F	WestPac/Vietnam
12 Nov 1971	17 Jul 1972	CVW-15	CVA 43	A-7E	WestPac/Vietnam
09 Mar 1973	08 Nov 1973	CVW-15	CVA 43	A-7E	WestPac
05 Dec 1974	02 Jul 1975	CVW-15	CVA 43	A-7E	WestPac
15 Feb 1977	05 Oct 1977	CVW-15	CV 43	A-7E	WestPac
30 May 1979	25 Feb 1980	CVW-15	CV 63	A-7E	WestPac/IO
01 Apr 1981	23 Nov 1981	CVW-15	CV-63	A-7E	WestPac/IO
01 Sep 1982	28 Apr 1983	CVW-11	CVN 65	A-7E	NorPac/WestPac/IO
30 May 1984	20 Dec 1984	CVW-11	CVN 65	A-7E	WestPac/IO/NorPac
12 Jan 1986	13 Aug 1986	CVW-11	CVN 65	A-7E	WestPac/IO/ Med/Solant
25 Oct 1987	24 Nov 1987	CVW-11	CVN 65	A-7E	NorPac
05 Jan 1988	03 Jul 1988	CVW-11	CVN 65	A-7E	WestPac/IO/NorPac
17 Sep 1989	16 Mar 1990	CVW-11	CVN 65	A-7E	World Cruise

\* On 29 March 1951 VF-63 and CVG-2 transferred from *Valley Forge* (CV 45) to *Philippine Sea* (CV 47) while in port Yokosuka, Japan.

**Air Wing Assignment**

<i>Air Wing</i>	<i>Tail Code</i>	<i>Assignment Date</i>
CVG-6	C	27 Jul 1948
CVG-2/CVW-2†	M/NE*	31 Jul 1950
CVW-19	NM	01 Oct 1968
CVW-5	NF	01 Nov 1968
COMFAIRLEMOORE		08 Jan 1971
CVW-15	NL	02 Jun 1971
CVW-11	NH	15 Jan 1982

\* CVG-2's tail code was changed from M to NE in 1957. The effective date was most likely the beginning of FY 58 (1 July 1957).

† Carrier Air Groups were redesignated Carrier Air Wings and CVG-2 became CVW-2 on 20 December 1963.

**Unit Awards Received**

<i>Unit Award</i>	<i>Inclusive Dates Covering Unit Award</i>
NAVE	Nov 1962 Feb 1964
	01 Jan 1979 30 Jun 1980
	01 Jul 1980 31 Dec 1981
AFEM	06 Sep 1958 10 Sep 1958
	12 Sep 1958 29 Sep 1958
	12 Oct 1958 30 Oct 1958
	11 Nov 1958 15 Nov 1958
	30 Nov 1958 12 Dec 1958
	24 Mar 1961 25 Mar 1961
	28 Mar 1961 07 Apr 1961
	09 Apr 1965 11 May 1965
	20 May 1965 28 Jun 1965



*A composite photograph of the different types of aircraft flown by the squadron between 1948 and 1965.*



*A squadron A-4C Skyhawk preparing for a launch from Midway (CVA 41) in June 1963.*

#### **Unit Awards Received—Continued**

<i>Unit Award</i>	<i>Inclusive Dates Covering Unit Award</i>	
	23 Jan 1968	22 Mar 1968
	29 Jun 1969	
	07 Jul 1969	13 Jul 1969
	24 Jul 1969	
	03 Sep 1969	
	13 Sep 1969	14 Sep 1969
	29 Apr 1975	30 Apr 1975
	15 May 1975	
	Mar 1988	
	17 Jan 1990	31 Jan 1990
HSM	29 Apr 1975	30 Apr 1975
	17 May 1981	
	02 Oct 1981	
	23 Oct 1982	
MUC	03 Dec 1967	09 May 1968
	15 Feb 1988	21 May 1988
NEM	25 Nov 1979	28 Jan 1980
	25 May 1981	30 Sep 1981
	30 Apr 1986	27 Jun 1986
NUC	Apr 1951	31 May 1951
	16 Apr 1965	04 Nov 1965
	12 Aug 1966	01 Feb 1967
	18 Apr 1969	08 Oct 1969
	02 May 1970	30 Oct 1970
	15 Dec 1971	01 Jul 1972
	22 Apr 1975	30 Apr 1975

#### **Unit Awards Received—Continued**

<i>Unit Award</i>	<i>Inclusive Dates Covering Unit Award</i>	
	15 May 1975	
	01 May 1979	23 Nov 1981
RVNGC	05 Oct 1965	
	09 Oct 1965	
	30 Mar 1972	01 Jul 1972
VNSM	22 Jul 1965	26 Aug 1965
	11 Sep 1965	09 Oct 1965
	18 Oct 1965	04 Nov 1965
	12 Sep 1966	19 Oct 1966
	30 Oct 1966	04 Dec 1966
	26 Dec 1966	01 Feb 1967
	03 Dec 1967	29 Dec 1967
	06 Jan 1968	28 Jan 1968
	18 Mar 1968	12 Apr 1968
	21 Apr 1968	09 May 1968
	17 Apr 1969	19 May 1969
	04 Jun 1969	26 Jun 1969
	31 Jul 1969	01 Sep 1969
	23 Sep 1969	09 Oct 1969
	02 May 1970	26 May 1970
	01 Jun 1970	14 Jun 1970
	10 Jul 1970	29 Jul 1970
	17 Aug 1970	03 Sep 1970
	11 Sep 1970	12 Sep 1970
	26 Sep 1970	21 Oct 1970
	14 Dec 1971	

**Unit Awards Received—Continued**

<i>Unit Award</i>	<i>Inclusive Dates Covering Unit Award</i>	
	31 Dec 1971	17 Jan 1972
	26 Jan 1972	17 Feb 1972
	01 Apr 1972	11 May 1972
	01 Jun 1972	11 Jun 1972
	21 Jun 1972	30 Jun 1972
KPUC	15 Sep 1950	26 Oct 1950
	Dec 1950	20 Mar 1951

**Unit Awards Received—Continued**

<i>Unit Award</i>	<i>Inclusive Dates Covering Unit Award</i>	
	Apr 1951	31 May 1951
	10 Mar 1952	9 Sep 1952
KSM	14 Sep 1950	26 Oct 1950
	16 Dec 1950	30 Mar 1951
	15 Apr 1951	2 Jun 1951
	10 Mar 1952	9 Sep 1952
UNSM	14 Sep 1950	26 Oct 1950
	10 Mar 1952	09 Sep 1952



*A squadron F/A-18C Hornet in flight, 1990.*



## VFA-25

### Lineage

Established as Torpedo Squadron SEVENTEEN (VT-17) on 1 January 1943.

Redesignated Attack Squadron SIX B (VA-6B) on 15 November 1946.

Redesignated Attack Squadron SIXTY FIVE (VA-65) on 27 July 1948.

Redesignated Attack Squadron TWENTY FIVE (VA-25) on 1 July 1959.

Redesignated Strike Fighter Squadron TWENTY FIVE (VFA-25) on 1 July 1983. The first squadron to be assigned the VFA-25 designation.

### Squadron Insignia and Nickname

The squadron's first insignia was approved by CNO on 28 September 1944. Colors for the four leaf clover, horseshoe and flying torpedo insignia were: a blue background with white shading; green four-leaf clover with black markings; white horseshoe with black markings; the wings and nose of the torpedo were yellow with black markings and the remaining part of the torpedo were white with black markings.



*The squadron's first insignia was indicative of its mission as a torpedo squadron.*

approved by CNO on 9 June 1949. Colors for the insignia are: a gold background with a black border; black fist with gold markings and a red lightning bolt. On 24 July 1959, CNO approved a modification to the insignia. The modified insignia added a scroll with the designation VA-25. The scroll was yellow with black markings and lettering.

On 24 January 1974 CNO approved another modification to the insignia, adding three black stars. When the squadron was designated VFA-25 it continued to use the fist and lightning bolt insignia but dropped the three stars.

Nickname: Fist of the Fleet, 1949-present.



*The clenched fist and lightning bolt became the squadron's second insignia and has been in use, with some modifications, since 1949.*



*This modification to the insignia was approved by CNO on 24 January 1974.*



*This is the current insignia used by the squadron.*

### Chronology of Significant Events

**10 Sep–2 Oct 1943:** The squadron was embarked in *Bunker Hill* (CV 17), enroute from Norfolk to Pearl Harbor via the Panama Canal and San Diego.

**11 Nov 1943:** The squadron flew its first combat sorties, striking targets in Rabaul.

**Nov 1943–Feb 1944:** The squadron flew numerous combat missions, striking targets in Kavieng, Kwajalein, Eniwetok, Truk and Tinian.

**2 Feb 1944:** During operations over Eniwetok, the squadron's commanding officer, Lieutenant Commander F. M. Whitaker, was lost in a midair collision.

**Feb 1945:** The squadron flew numerous combat missions against targets in Japan and the Bonin Islands and provided ground support for the invasion of Iwo Jima.

**19 Mar 1945:** For their actions against the Japanese Fleet in the Kure Bay area of the Inland Sea, the following squadron personnel were awarded the Navy Cross: Lieutenant Commander W. M. Romberger; Lieutenant H. E. Clark; Lieutenant (jg)s T. J. Coghlan, H. W. Foote, H. C. Johnson, A. C. Traxler and Ensign J. Behl. Lieutenant J. A. Tew was awarded the Silver Star for his actions during this attack.

**Mar 1945:** Squadron aircraft struck Japanese ships in the East China Sea, Inland Sea and around the Ryukyu Islands and land based targets in and around Okinawa.

**7 Apr 1945:** VT-17, along with other units from the task force, attacked a Japanese naval force composed of the superbattleship *Yamato* and her escorts. Squadron aircraft scored several torpedo hits on the *Yamato* and sunk one of her destroyer escorts. For their actions in this battle the following squadron personnel were awarded the Navy Cross: Lieutenants T. C. Durkin and S. G. Sullivan; Lieutenant (jg) J. F. Monaghan and Ensign W. F. Nickel. Lieutenant H. E. Clark, Lieutenant (jg) T. J. Coghlan and Ensign R. S. Hanlon were awarded the Silver Star for their actions.

**Apr 1945:** Combat missions were flown against tar-

gets in and around Okinawa in preparation for the invasion of that island.

**May–Jun 1945:** VT-17 aircraft struck targets in and around Okinawa, Kyushu, Shikoku and ships in the East China Sea.

**27 Oct–23 Nov 1949:** VA-65, embarked in *Franklin D. Roosevelt* (CVB 42), operated in the Davis Straits area conducting cold weather exercises.

**15 Sep 1950:** Squadron aircraft participated in combat strikes against shore defenses in and around Inchon, Korea, just before the landings at Inchon.

**1 Oct 1950:** Squadron aircraft struck the North Korean capital of P'yongyang, hitting the airfield and scoring a direct hit on a large electrical power plant.

**23 Jun 1952:** Squadron aircraft participated in a coordinated four carrier strike on North Korean hydro-electric power plants. VA-65's Skyraiders hit the Suiho power plant on the Yalu River.

**6 Aug 1952:** Embarked in *Boxer*, the squadron was preparing for routine combat operations when a fire broke out on the hangar deck. Squadron personnel assisted in removing armed ordnance from planes on the flight deck and helped fight the fire on the hangar deck. One casualty was suffered by the squadron as a result of the fire.

**Feb 1955:** While embarked in *Essex* (CVA 9) and operating in the Formosa Straits, the squadron provided air support during the evacuation of Nationalist Chinese forces from the Tachen Islands which had come under bombardment by the People's Republic of China.

**25 Aug 1958:** *Midway* (CVA 41), with VA-65 embarked, was ordered to discontinue its ORI and proceed to the vicinity of Taiwan following the shelling of the Quemoy Islands on 23 August by the Chinese Communists.

**Mar 1961:** The squadron, while embarked in *Midway*, operated in the South China Sea due to the crisis in Laos.

**Apr 1965:** The squadron engaged in its first combat operations in the Vietnam theater.

**20 Jun 1965:** Four of the squadron's Skyraiders engaged enemy fighters over North Vietnam resulting in the shoot down of a MiG-17. Lieutenant Clinton B. Johnson and Lieutenant (jg) Charles W. Hartman III were awarded Silver Stars for their actions in downing the MiG-17.

**14 Sep 1966:** While on a combat sortie near Vinh, North Vietnam, the squadron's commanding officer, Commander C. W. Stoddard, was shot down by a surface-to-air missile and lost at sea.

**Jan 1968:** Squadron aircraft provided close air support for U.S. Marines besieged at Khe Sanh, South Vietnam.

**6 Apr 1968:** The squadron returned to NAS Lemoore from a combat deployment to Vietnam, bringing to a close an era for the A-1 Skyraider. It was the last

attack squadron to deploy and operate the A-1. The A-1's last combat mission with VA-25 came to an end on 20 February when the aircraft touched down on the deck of *Coral Sea* (CVA 43).

**Apr 1969:** Following the shoot down of a Navy EC-121 aircraft by the North Koreans, *Ticonderoga* (CVA 14), with VA-25 embarked, was ordered to the Sea of Japan.

**21 Nov 1970:** Squadron aircraft flew Rescue Combat Air Patrol sorties while an Army-Air Force search and rescue team landed at the Son Tay POW compound, 20 miles west of Hanoi, in an attempt to free American POWs. Unfortunately the POW compound had already been evacuated by the North Vietnamese.

**Dec 1972:** The squadron participated in Linebacker II Operations, heavy air strikes against targets primarily around Hanoi and Haiphong.

**15 Jan 1973:** The squadron participated with several other squadrons in a large laser bombing attack against bridge targets in North Vietnam. This coordinated strike used the A-6's Pave Knife Laser Designation System to guide laser-guided bombs dropped by A-7 aircraft.

**Jan–Feb 1973:** Following the cease fire with North Vietnam on 27 January, the squadron concentrated its attention on strikes against lines-of-communication targets in Laos until an agreement was reached with that country.

**Jul 1976:** Following the Israeli raid on Entebbe and the threatened military operations against Kenya by Uganda, the *Ranger* (CV 61), with VA-25 embarked, was ordered to transit from the South China Sea to the western Indian Ocean and operate off the coast of Kenya.

**21 Feb 1985:** VFA-25 and 113, embarked in *Constellation* (CV 64), were the first to deploy with the F/A-18 Hornet. During the deployment the Hornets operated in the western Pacific and Indian Ocean.

**Jul 1987:** Due to the increased attacks on merchant and tanker shipping in the Persian Gulf during the Iran/Iraqi War, the United States began to escort reflagged Kuwaiti oil tankers. During operation Earnest Will, VFA-25 provided air cover for reflagged tankers transiting the Straits of Hormuz.

**Aug 1990:** Due to the invasion of Kuwait by Iraq, *Independence* (CV 62), with VFA-25 embarked, was ordered to operate in the Gulf of Oman.

**Aug–Nov 1990:** VFA-25 flew sorties from *Independence* in support of Operation Desert Shield, the build-up of American and Allied forces to counter a threatened invasion of Saudi Arabia by Iraq and as part of an economic blockade of Iraq to force its withdrawal from Kuwait. On 2 October *Independence* entered the Persian Gulf and operated in those waters for two days before returning to the Northern Arabian Sea and being relieved on station by *Midway* (CV 41).



*A squadron TBF-1C prepares to take off from Bunker Hill (CV 17) during its combat cruise on the carrier from October 1943 to March 1944.*

### Home Port Assignments

<i>Location</i>	<i>Assignment Date</i>
NAS Norfolk	01 Jan 1943
NAS Kaneohe	03 Oct 1943*
NAS Alameda	10 Mar 1944†
NAS Hilo	12 Nov 1944*
NAB Agana	28 Dec 1944*
NAS Alameda	08 Jul 1945
NAAS Fallon	Sep 1945
NAS Brunswick	01 Feb 1946
NAS Norfolk	15 Aug 1946
NAAS Oceana	05 Mar 1949
NAS Alameda	15 Aug 1950
NALF Santa Rosa	11 Jul 1951
NAS Alameda	25 Sep 1952
NAS Moffett Field	28 Sep 1961
NAS Lemoore	07 Jan 1963

\* Temporary shore assignment while the squadron conducted training in preparation for combat deployment.

† During the squadron's reforming and training cycle it operated from numerous other shore stations, including NAAS Monterey, NAAS Vernalis, and NAAS Arcata.

### Commanding Officers

	<i>Date Assumed Command</i>
LCDR Frank M. Whitaker	01 Jan 1943
LT Gordon N. Owens	02 Feb 1944
LT Jack Martin (acting)	18 Apr 1944
LCDR William M. Romberger	02 May 1944
LT Arnold C. Traxler (acting)	18 Aug 1945
LCdr William N. Janes (acting)	21 Aug 1945
CDR Rubin H. Konig	11 Oct 1945
LCDR Glen B. Butler	31 Oct 1947
LCDR Michael J. Hanley	08 Dec 1948
CDR Richard W. Phillips	01 Feb 1950
CDR Gordon A. Sherwood	31 Aug 1951
LCDR Marvin R. Novak (acting)	22 Oct 1952

### Commanding Officers—Continued

	<i>Date Assumed Command</i>
LCDR Harry M. Thompson	28 Oct 1952
LCDR J. A. Rapp	12 Mar 1954
CDR John R. Bowen II	15 Jul 1955
CDR William C. Bates	22 May 1957
CDR Edward V. Izac, Jr.	15 May 1958
CDR John W. Fairbanks	03 Apr 1959
CDR Warren H. Ireland	08 Apr 1960
LCDR M. E. Mann (acting)	11 May 1960
CDR William S. Hertig	16 May 1960
CDR C. R. Bradford	03 Aug 1961
CDR John A. Overn	11 Aug 1962
CDR Herman W. Presson	25 Jun 1963
CDR Ralph F. Smith	29 May 1964
CDR Harry E. Ettinger	24 May 1965
CDR C. William Stoddard	13 Apr 1966
CDR James D. Burden	14 Sep 1966
CDR Clifford E. Church	01 Oct 1967
CDR Scott L. Smith	Mar 1968
CDR Fred J. Orrik	09 Jun 1969
CDR F. M. Humphreys	26 Jun 1970
CDR Juan H. Carcaba	26 May 1971
CDR Edwin A. Greathouse	19 May 1972
CDR Paul M. Moore	02 Jun 1973
CDR George R. Vezina	05 May 1974
CDR Peter W. Ogle	08 Jul 1975
CDR James B. Hamilton	29 Oct 1976
CDR Warner L. Butler	31 Jan 1978
CDR Donald J. Wright	26 Mar 1979
CDR John A. Lockard	29 Jul 1980
CDR Robert W. Leone	07 Oct 1981
CDR Steve L. Webb	25 Apr 1983
CDR C. J. Leslie	16 Nov 1984
CDR Jeorme L. Arbiter	Feb 1986
CDR Anthony V. Colantoni, Jr.	02 Sep 1987
CDR Daniel W. Gabriel	23 Nov 1988
CDR Gregory R. Peairs	31 May 1990

**Aircraft Assignment**

<i>Type of Aircraft</i>	<i>Date Type First Received</i>
TBF-1	Jan 1943
TBF-1C	Oct 1943
TBM-1	May 1944
TBM-1C	Oct 1944
TBM-3	Feb 1945
TBM-3E	Sep 1945
SB2C-4E	Mar 1946
SB2C-5	Nov 1946
AD-1	23 Sep 1947
AD-1Q	Jul 1948
AD-4	02 Dec 1949
AD-3	14 Nov 1950
AD-2	05 Dec 1950
AD-4Q	05 Dec 1950

**Aircraft Assignment—Continued**

<i>Type of Aircraft</i>	<i>Date Type First Received</i>
AD-1/2/3/4	1951*
AD-4NA	03 Dec 1952
AD-4B	23 Dec 1952
AD-5	Jul 1955
AD-6/A-1H†	Jul 1955
AD-7/A-1J†	Apr 1959
A-7B	Oct 1968
A-7E	Dec 1969
F/A-18A	11 Nov 1984
F/A-18C	Jun 1989

\* Between July and December 1951 the squadron received and transferred numerous models of the AD Skyraider.

† The AD-6 and AD-7 designations were changed to A-1H and A-1J respectively in 1962.



*Photo of squadron officers aboard Philippine Sea (CV 47) in 1951. A squadron AD-2 Skyraider is in the background.*

**Major Overseas Deployments**

<i>Date of Departure</i>	<i>Date of Return</i>	<i>Air Wing</i>	<i>Carrier</i>	<i>Type of Aircraft</i>	<i>Area of Operation</i>
21 Oct 1943	04 Mar 1944	CVG-17	CV 17	TBF-1C	Pacific*
02 Feb 1945	08 Jul 1945	CVG-17	CV 12	TBM-1C/3	Pacific†
04 Jan 1949	05 Mar 1949	CVG-6	CVB 41	AD-1	Med
24 Aug 1950	11 Nov 1950	CVG-2	CV 21	AD-4	WestPac/Korea
06 Dec 1950	09 Jun 1951	CVG-2	‡	AD-2	WestPac/Korea
08 Feb 1952	26 Sep 1952	CVG-2	CV 21	AD-4	WestPac/Korea
03 Aug 1953	03 Mar 1954	CVG-2	CVA 10	AD-4B/NA	WestPac
03 Nov 1954	21 Jun 1955	CVG-2	CVA 9	AD-4/4B	WestPac
13 Nov 1956	22 May 1957	CVG-2	CVA 38	AD-6	WestPac
16 Aug 1958	12 Mar 1959	CVG-2	CVA 41	AD-6	WestPac
15 Aug 1959	25 Mar 1960	CVG-2	CVA 41	AD-7	WestPac
16 Feb 1961	28 Sep 1961	CVG-2	CVA 41	AD-7	WestPac
06 Apr 1962	20 Oct 1962	CVG-2	CVA 41	A-1H/J	WestPac
08 Nov 1963	26 May 1964	CVW-2	CVA 41	A-1H/J	WestPac
06 Mar 1965	23 Nov 1965	CVW-2	CVA 41	A-1H/J	WestPac/Vietnam
29 Jul 1966	23 Feb 1967	CVW-2	CVA 43	A-1H	WestPac/Vietnam
26 Jul 1967	06 Apr 1968	CVW-15	CVA 43	A-1H/J	WestPac/Vietnam
01 Feb 1969	18 Sep 1969	CVW-16	CVA 14	A-7B	WestPac/Vietnam
27 Oct 1970	17 Jun 1971	CVW-2	CVA 61	A-7E	WestPac/Vietnam
16 Nov 1972	23 Jun 1973	CVW-2	CVA 61	A-7E	WestPac/Vietnam
07 May 1974	18 Oct 1974	CVW-2	CVA 61	A-7E	WestPac
30 Jan 1976	07 Sep 1976	CVW-2	CV 61	A-7E	WestPac/IO
21 Feb 1979	22 Sep 1979	CVW-2	CV 61	A-7E	WestPac
10 Sep 1980	05 May 1981	CVW-2	CV 61	A-7E	WestPac/IO
07 Apr 1982	19 Oct 1982	CVW-2	CV 61	A-7E	WestPac/IO
21 Feb 1985	24 Aug 1985	CVW-14	CV 64	F/A-18A	WestPac/IO
04 Sep 1986	20 Oct 1986	CVW-14	CV 64	F/A-18A	NorPac
11 Apr 1987	13 Oct 1987	CVW-14	CV 64	F/A-18A	WestPac/IO
01 Dec 1988	01 Jun 1989	CVW-14	CV 64	F/A-18A	WestPac/IO
16 Sep 1989	19 Oct 1989	CVW-14	CV 64	F/A-18A/C	NorPac
23 Jun 1990	20 Dec 1990	CVW-14	CV 62	F/A-18C	WestPac/IO/ Persian Gulf

\* The combat deployment time frame covers the squadron's departure from Pearl Harbor aboard *Bunker Hill* (CV 17) and its return to Pearl Harbor on 4 March 1944. The squadron detached from *Bunker Hill* on 4 March and returned to the States on 10 March 1944.

† The combat deployment time frame covers the squadron's 2 February 1945 embarkation in *Hornet* (CV 12) at Ulithi atoll and its return to the States on 8 July 1945.

‡ VA-65 deployed to Korea embarked in *Valley Forge* (CV 45). On 29 March 1951 the squadron, along with the rest of CVG-2, transferred to *Philippine Sea* (CV 47) for continued operations in Korea. It returned to the States embarked in *Philippine Sea*.



*Squadron A-1H Skyraiders on the deck of Coral Sea (CVA 43) in 1966 during their deployment to Vietnam.*

### Air Wing Assignments

<i>Air Wing</i>	<i>Tail Code</i>	<i>Assignment Date</i>
CVG-17/CVBG-17/ CVBG-5/CVG-6*	C†	01 Jan 1943
CVG-2/CVW-2§	M/NE‡	01 Aug 1950
CVW-15	NL	31 Mar 1967
COMFAIRALAMEDA		1968**
CVW-16	AH	1968
CVW-2	NE	1970***
CVW-14	NK	Jan 1984

\* CVG-17 was established on 1 January 1943. It was redesignated CVBG-17 on 22 January 1946 and then became CVBG-5 on 15 November 1946. The CVGB-5 designation was changed to CVG-6 on 27 July 1948.

† The tail code was assigned to CVBG-5 on 12 December 1946.

‡ The tail code was changed from M to NE in 1957. The effective date for this change was most likely the beginning of FY 58 (1 July 1957).

§ CVG-2 was redesignated CVW-2 when Carrier Air Groups (CVG) were redesignated Carrier Air Wings (CVW) on 20 December 1963.

\*\* During the squadron's transition to the A-7B Corsair II, its administrative superior was Commander Fleet Air Alameda. Once the transition was complete it was assigned to CVW-16.

\*\*\* CVW-2 returned from a WestPac deployment on 1 June 1970 and VA-25 was assigned to the air wing sometime in the summer or fall of 1970.

### Unit Awards Received

<i>Unit Award</i>	<i>Inclusive Dates Covering Unit Award</i>	
PUC	11 Nov 1943	23 Feb 1944
	16 Feb 1945	10 Jun 1945
NAVE	01 Jul 1948	30 Jun 1949
	01 Jul 1949	30 Jun 1950
	01 Jul 1964	30 Jun 1965
	01 Jan 1986	31 Dec 1986
	01 Jan 1987	31 Dec 1987
	01 Jan 1990	31 Dec 1990
KSM	14 Sep 1950	26 Oct 1950
	16 Dec 1951	30 Mar 1951
	15 Apr 1951	02 Jun 1951
	10 Mar 1952	09 Sep 1952
HSM	25 May 1976	01 Jun 1976
	20 Mar 1981	
NUC	29 Mar 1951	31 May 1951
	16 Apr 1965	04 Nov 1965
	12 Aug 1966	01 Feb 1967
	13 Aug 1967	19 Feb 1968
	02 Aug 1990	
	01 Nov 1990	
AFEM	06 Sep 1958	10 Sep 1958
	12 Sep 1958	29 Sep 1958



*A squadron A-7E Corsair II at NAS North Island, California, in 1975.*

**Unit Awards Received—Continued**

<i>Unit Award</i>	<i>Inclusive Dates Covering Unit Award</i>	
	12 Oct 1958	30 Oct 1958
	11 Nov 1958	15 Nov 1958
	30 Nov 1958	12 Dec 1958
	24 Mar 1961	25 Mar 1961
	28 Mar 1961	07 Apr 1961
	09 Apr 1965	11 May 1965
	20 May 1965	28 Jun 1965
	20 Apr 1967	27 Apr 1967
	23 Jan 1968	22 Mar 1968
	20 Apr 1969	27 Apr 1969
	04 Aug 1969	
	16 Aug 1969	24 Aug 1969
	30 Aug 1969	
MUC	18 Feb 1969	07 Sep 1969
	18 Nov 1970	02 Jun 1971
	01 Jan 1988	31 Aug 1989
NEM	30 Oct 1980	12 Mar 1981
RVNGC	05 Oct 1965	
	09 Oct 1965	
	20 Nov 1966	21 Nov 1966
	29 Dec 1966	
	23 Nov 1967	
	02 Dec 1967	
	04 Dec 1967	
	20 Dec 1967	22 Dec 1967
	20 Jan 1968	
	23 Jan 1968	27 Jan 1968
	29 Jan 1968	19 Feb 1968
	04 Mar 1969	08 Mar 1969
	10 Mar 1969	
	12 Mar 1969	19 Mar 1969
	29 Mar 1969	31 Mar 1969

**Unit Awards Received—Continued**

<i>Unit Award</i>	<i>Inclusive Dates Covering Unit Award</i>	
	02 Apr 1969	03 Apr 1969
	06 Apr 1969	07 Apr 1969
	09 Apr 1969	15 Apr 1969
	10 May 1969	29 May 1969
	31 May 1969	03 Jun 1969
	28 Jun 1969	30 Jun 1969
VNSM	22 Jul 1965	26 Aug 1965
	10 Sep 1965	09 Oct 1965
	18 Oct 1965	04 Nov 1965
	12 Sep 1966	19 Oct 1966
	30 Oct 1966	
	01 Nov 1966	04 Dec 1966
	26 Dec 1966	01 Feb 1967
	26 Aug 1967	01 Oct 1967
	12 Oct 1967	28 Oct 1967
	04 Nov 1967	05 Nov 1967
	11 Nov 1967	08 Dec 1967
	16 Dec 1967	07 Jan 1968
	15 Jan 1968	21 Feb 1968
	03 Mar 1969	20 Mar 1969
	29 Mar 1969	16 Apr 1969
	09 May 1969	04 Jun 1969
	25 Jun 1969	01 Aug 1969
	18 Nov 1970	18 Dec 1970
	27 Dec 1970	13 Jan 1971
	02 Feb 1971	17 Mar 1971
	31 Mar 1971	18 Apr 1971
	25 Apr 1971	18 May 1971
	09 Dec 1972	03 Jan 1973
	14 Jan 1973	30 Jan 1973
	01 Feb 1973	06 Feb 1973
SASM	05 Aug 1990	04 Nov 1990



*Two squadron F/A-18 Hornets on deck preparing to launch, circa 1988 or 1989.*

## VFA-27

### Lineage

Established as Attack Squadron TWENTY SEVEN (VA-27) on 1 September 1967.

Redesignated Strike Fighter Squadron TWENTY SEVEN (VFA-27) on 24 January 1991. The first squadron to be assigned the VFA-27 designation.

### Squadron Insignia and Nickname

The squadron's insignia was approved by the CNO on 25 March 1968. Colors for the glove and mace



The squadron's Royal Maces insignia with the VA-27 (Attack Squadron 27) designation in the scroll.



The squadron maintained the same insignia design following its redesignation to VFA-27. The only change was the designation in the scroll.

insignia are as follows: sky blue background with a white cloud outlined in blue; light blue glove outlined in black and with USN in white; orange-red mace handle with a black mace, outlined in white; white scroll outlined in black with black lettering.

Nickname: Royal Maces, 1968-present.

### Chronology of Significant Events

**28 Jun 1968:** The squadron flew its first combat sortie, striking targets in the panhandle region of North Vietnam.

**4 Feb–7 Mar 1971:** VA-27 embarked in *Enterprise* (CVAN 65), conducted training flights during the carrier's transit around Cape Horn to her new home port in California.

**Dec 1971:** With the outbreak of war between India and Pakistan over East Pakistan (later Bangladesh), *Enterprise* departed Yankee Station and made a quick transit to the Indian Ocean to provide support for the evacuation of foreign civilians from East Pakistan.

**Oct 1972:** Participated in Linebacker I operations, heavy air strikes against targets in North Vietnam to interdict the flow of supplies in that country and into South Vietnam.

**Dec 1972:** Participated in Linebacker II operations, an intensified version of Linebacker I operations.

**Feb 1975:** *Enterprise*, with CVW-14, provided disas-

ter support for the island country of Mauritius following a tropical storm.

**Apr 1975:** Participated in operation Frequent Wind and provided air support for helicopters evacuating personnel from Saigon as it fell to the communists.

**Feb 1977:** During the crisis in Uganda and threats against Americans in that country, *Enterprise* operated off the coast of Kenya for possible support in the evacuation of Americans.

**Dec 1979:** *Coral Sea* (CV 43) operated off the coast of South Korea following the assassination of South Korea's President Park Chung-Hee in late October.

**Apr 1980:** The squadron participated in the Iranian hostage rescue attempt by providing air cover for the forces directly involved in the rescue operation.

**May 1980:** Following civil unrest in South Korea, *Coral Sea* operated off the coast of that country.

**Aug 1983:** Due to the unsettled conditions in Central America, *Coral Sea* (CV 43) operated off the coast of Nicaragua.

**Aug 1986:** The squadron participated in the first carrier tactical flight operations in the Bering Sea since the end of World War II.

### Home Port Assignments

Location	Assignment Date
NAS Lemoore	01 Sep 1967

### Commanding Officers

	Date Assumed Command
CDR George T. Pappas	01 Sep 1967
CDR Donald L. Felt	28 Feb 1969
CDR Thomas W. Durant	04 Feb 1970
CDR Leroy B. Keeley	22 Jan 1971
CDR Jerome L. Johnson	22 Dec 1971
CDR Leon A. Edney	15 Dec 1972
CDR Meredith W. Patrick	09 Jan 1974
CDR James A. Kenney	07 Mar 1975
CDR Dale A. Iverson	28 May 1976
CDR Richard K. Pottratz	01 Aug 1977
CDR James W. Partington	30 Nov 1978
CDR James S. Zayicek	10 May 1980
CDR Dennis V. McGinn	24 Sep 1981
CDR Joseph E. Hart	16 Dec 1982
CDR Hugh D. Connell II	01 May 1984
CDR Joseph P. Sciabarra	25 Oct 1985
CDR Malcolm P. Branch	29 May 1987
CDR Richard E. Clayton	03 Sep 1988
CDR Stanford H. Hlavka	29 Mar 1990

### Aircraft Assignment

Type of Aircraft	Date Type First Received
A-7A	Jan 1969
A-7E	30 Jun 1970
F/A-18A	20 Feb 1991





*Two squadron A-7E Corsair IIs fly along a deserted coast line during their deployment to the Indian Ocean, 1986.*

### **Major Overseas Deployments**

<i>Date of Departure</i>	<i>Date of Return</i>	<i>Air Wing</i>	<i>Carrier</i>	<i>Type of Aircraft</i>	<i>Area of Operation</i>
28 May 1968	31 Jan 1969	CVW-14	CVA 64	A-7A	WestPac/Vietnam
11 Aug 1969	08 May 1970	CVW-14	CVA 64	A-7A	WestPac/Vietnam
11 Jun 1971	12 Feb 1972	CVW-14	CVAN 65	A-7E	WestPac/ Vietnam/IO
12 Sep 1972	11 Jun 1973	CVW-14	CVAN 65	A-7E	WestPac/Vietnam
17 Sep 1974	20 May 1975	CVW-14	CVAN 65	A-7E	WestPac /IO
30 Jul 1976	28 Mar 1977	CVW-14	CVN 65	A-7E	WestPac/IO
04 Apr 1978	30 Oct 1978	CVW-14	CVN 65	A-7E	WestPac/IO
13 Nov 1979	11 Jun 1980	CVW-14	CV 43	A-7E	WestPac/IO
20 Aug 1981	23 Mar 1982	CVW-14	CV 43	A-7E	WestPac/IO
21 Mar 1983	12 Sep 1983	CVW-14	CV 43	A-7E	World Cruise
13 Oct 1984	24 May 1985	CVW-15	CVN 70	A-7E	WestPac/IO
12 Aug 1986	05 Feb 1987	CVW-15	CVN 70	A-7E	WestPac/IO
15 Jun 1988	14 Dec 1988	CVW-15	CVN 70	A-7E	WestPac/IO
05 Sep 1989	09 Nov 1989	CVW-15	CVN 70	A-7E	NorPac/WestPac
01 Feb 1990	29 Jul 1990	CVW-15	CVN 70	A-7E	WestPac/IO

**Air Wing Assignments**

<i>Air Wing</i>	<i>Tail Code</i>	<i>Assignment Date</i>
COMFAIRALAMEDA		01 Sep 1967
CVW-14	NK	05 Jan 1968
CVW-15	NL	21 Nov 1983

**Unit Awards Received—Continued**

<i>Unit Award</i>	<i>Inclusive Dates Covering Unit Award</i>	
	11 Sep 1968	09 Oct 1968
	23 Oct 1968	29 Nov 1968
	09 Dec 1968	21 Dec 1968
	01 Jan 1969	07 Jan 1969
	11 Sep 1969	03 Oct 1969
	01 Nov 1969	23 Nov 1969
	07 Dec 1969	22 Dec 1969
	05 Jan 1970	30 Jan 1970
	12 Feb 1970	01 Mar 1970
	26 Mar 1970	17 Apr 1970
	14 Jul 1971	31 Jul 1971
	15 Aug 1971	14 Sep 1971
	12 Sep 1971	
	25 Sep 1971	26 Sep 1971
	02 Oct 1972	23 Oct 1972
	01 Nov 1972	11 Dec 1972
	18 Dec 1972	13 Jan 1973
	24 Jan 1973	23 Feb 1973
	01 Mar 1973	02 Mar 1973
	11 Mar 1973	28 Mar 1973
HSM	29 Apr 1975	30 Apr 1975
NAVE	01 Jan 1985	31 Dec 1985

**Unit Awards Received**

<i>Unit Award</i>	<i>Inclusive Dates Covering Unit Award</i>	
AFEM	16 Oct 1969	24 Oct 1969
	16 Mar 1970	23 Mar 1970
	29 Apr 1975	30 Apr 1975
MUC	14 Jun 1968	23 Jan 1969
	07 Sep 1969	30 Apr 1970
	02 Jul 1971	03 Feb 1972
	22 Apr 1975	30 Apr 1975
	10 Nov 1984	07 May 1985
	16 Jan 1987	02 Feb 1987
NEM	01 Feb 1980	05 May 1980
	11 Oct 1981	20 Oct 1981
NUC	03 Oct 1972	22 Feb 1973
VNSM	27 Jun 1968	22 Jul 1968
	02 Aug 1968	28 Aug 1968



*A squadron F/A-18A Hornet in flight, 1992.*

## VFA-37

### Lineage

Established as Attack Squadron THIRTY SEVEN (VA-37) on 1 July 1967.

Redesignated Strike Fighter Squadron THIRTY SEVEN (VFA-37) on 28 November 1990. The first squadron to be assigned the VFA-37 designation.

### Squadron Insignia and Nickname

The squadron's insignia was approved by CNO on 26 March 1968. A design centering on a Bull was selected to symbolize the spirit, pride and mission of the unit. The insignia colors are as follows: a light blue circular background surrounded by a white border outlined in black; red-brown bull with a black mane, white horns tipped with red and the nostrils emitting clouds of white steam; white teeth and a red eye; and a dark blue scroll outlined in black with lettering in white.



*The squadron has used the Bulls insignia since March 1968.*

Nickname: Bulls, 1968-present.

### Chronology of Significant Events

Jul–Nov 1967: Squadron personnel were trained by VA-174 in the operation of the A-7A Corsair II.

Sep 1970: Fighting erupted between Palestinian forces and the Jordanian Army as a result of the Palestinian hijacking of several civilian airliners to Jordan. *Saratoga* (CVA 60) with its embarked air wing, including VA-37, was directed to operate in the eastern Mediterranean in response to this crisis. The conflict intensified when Syria invaded Jordan and VA-37 remained on station until the latter part of September when the Jordanian Army had successfully repulsed the Syrians and the crisis had abated.

29 Sep 1970: VA-37 participated in an air power demonstration for President Nixon during his two day visit to *Saratoga* while she steamed in the Med.

Jun–Oct 1971: VA-37 participated in the test and evaluation of the new CV concept during the *Saratoga's* deployment to the North Atlantic and the Mediterranean Sea. The CV concept involved combining the capabilities of the attack and antisubmarine carriers (CVA and CVS) into a single ship.

1 Aug 1972: While on a combat mission near the island of Hon Nieu, off the coast of North Vietnam, a squadron's A-7A Corsair II was used to establish a sonobuoy field in an anchorage area. This was the first time an A-7 had ever been used to drop sonobuoys.

Jun 1982: *John F. Kennedy*, with VA-37 embarked, took station off the coast of Lebanon after Israel invaded that country.

Jun 1984: The primary mission of the squadron was changed to close air support in preparation for its deployment to MCAS Iwakuni as part of the Marine Corps Unit Deployment Program. VA-37's deployment was scheduled as a replacement for a Marine Corps A-4M squadron. Two Navy A-7 squadrons had been selected for the program because the A-7 Corsair II was very similar in size and make-up to a Marine Corps A-4 Skyhawk squadron. The deployment of the two Navy attack squadrons was designed to test the interoperational abilities of the Marine Corps and Navy.

Dec 1984: VA-37 deployed to MCAS Iwakuni and relieved VA-105. VA-105 was the first Navy squadron to participate in the Marine Corps Unit Deployment Program and it was also the first time a Navy squadron came under the operational control of the Marine Corps since World War II.

Mar 1985: While deployed to MCAS Iwakuni, the squadron was detached to Yechon, Korea, to participate in exercise Team Spirit 85. This was the first time a Navy carrier-based squadron had deployed in field conditions since World War II.



*A formation of squadron A-7E Corsair IIs, 1989.*

**Home Port Assignments**

Location	Assignment Date
NAS Cecil Field	01 Jul 1967

**Commanding Officers**

	<i>Date Assumed Command</i>
CDR James A. Burnett	01 Jul 1967
CDR J. R. Tappan	08 Nov 1968
CDR K. E. Moranville	Sep 1969
CDR C. B. Hawkins, Jr.	03 Jul 1970
CDR Thomas F. Brown III	28 May 1971
CDR Jerome F. Watson	07 Jan 1972
CDR Clarence E. Armstrong	22 Feb 1973
CDR James W. Keathley	21 Mar 1974
CDR George K. Coyne, Jr.	10 Jul 1975
CDR Richard W. Hamon	15 Oct 1976
CDR Robert J. Spane	12 Jan 1978

**Commanding Officers—Continued**

	<i>Date Assumed Command</i>
CDR A. Coward IV	18 Apr 1979
CDR W. B. Christie	03 Jul 1980
CDR Leroy A. Farr	21 Oct 1981
CDR Robert L. Ramsay III	01 Feb 1983
CDR Brian L. Lehman	12 Jul 1984
CDR Jeffrey Harrison	05 Dec 1985
CDR James R. O'Hora	02 Jul 1987
CDR L. Scott Jacobsen	14 Dec 1988
CDR Carroll L. White	22 Jun 1990

**Aircraft Assignment**

<i>Type of Aircraft</i>	<i>Date Type First Received</i>
A-7A	Aug 1967
A-7E	23 Apr 1973
F/A-18A	13 Dec 1990

**Major Overseas Deployments**

<i>Date of Departure</i>	<i>Date of Return</i>	<i>Air Wing</i>	<i>Carrier</i>	<i>Type of Aircraft</i>	<i>Area of Operation</i>
30 Dec 1968	04 Sep 1969	CVW-11	CVA 63	A-7A	WestPac/Vietnam
17 Jun 1970	09 Nov 1970	CVW-3	CVA 60	A-7A	Med
07 Jun 1971	28 Oct 1971	CVW-3	CVA 60	A-7A	NorLant/Med
11 Apr 1972	13 Feb 1973	CVW-3	CV 60	A-7A	SoLant/IO/West Pac/Vietnam
27 Sep 1974	19 Mar 1975	CVW-3	CV 60	A-7E	Med
06 Jan 1976	28 Jul 1976	CVW-3	CV 60	A-7E	Med
11 Jul 1977	23 Dec 1977	CVW-3	CV 60	A-7E	Med
03 Oct 1978	05 Apr 1979	CVW-3	CV 60	A-7E	Med
10 Mar 1980	27 Aug 1980	CVW-3	CV 60	A-7E	Med
04 Jan 1982	14 Jul 1982	CVW-3	CV 67	A-7E	Med/IO
01 Mar 1983	29 Oct 1983	CVW-15	CVN 70	A-7E	World Cruise
01 Dec 1984	14 Jun 1985	MAG-12	MCAS Iwakuni	A-7E	Japan/WestPac
02 Jun 1986	10 Nov 1986	CVW-6	CV 59	A-7E	Med
28 Aug 1987	09 Oct 1987	CVW-6	CV 59	A-7E	NorLant
25 Apr 1988	07 Oct 1988	CVW-6	CV 59	A-7E	Med/IO/NorLant
04 Nov 1989	12 Apr 1990	CVW-6	CV 59	A-7E	Med

**Air Wing Assignments**

<i>Air Wing</i>	<i>Tail Code</i>	<i>Assignment Date</i>
COMFAIRJACKSON-VILLE		Jul 1967
CVW-11	NH	Oct 1968
COMFAIRJACKSON-VILLE		Sep 1969
CVW-3	AC	Jan 1970
CVW-15	NL	01 Oct 1982

**Air Wing Assignments—Continued**

<i>Air Wing</i>	<i>Tail Code</i>	<i>Assignment Date</i>
COMLATWING ONE		Oct 1983
MAG-12, 1st MAW*		01 Dec 1984
CVW-6	AE	Aug 1985
COMLATWING ONE		01 Oct 1990

\* VA-37 was assigned to MAG-12, 1st MAW during its shorebased deployment to MCAS Iwakuni, Japan.

**Unit Awards Received**

<i>Unit Award</i>	<i>Inclusive Dates Covering Unit Award</i>	
NAVE	01 Jul 1971	31 Dec 1972
	01 Jan 1989	31 Dec 1989
MUC	17 Sep 1970	18 Oct 1970
	04 May 1971	17 May 1972
	09 Jan 1973	03 May 1977
	01 Oct 1979	15 Nov 1980
	01 Jan 1989	01 Apr 1990
NUC	15 Jan 1969	27 Aug 1969
	18 May 1972	08 Jan 1973
VNSM	27 Jan 1969	01 Mar 1969
	12 Mar 1969	05 Apr 1969
	17 Apr 1969	10 May 1969

**Unit Awards Received—Continued**

<i>Unit Award</i>	<i>Inclusive Dates Covering Unit Award</i>	
	28 Jun 1969	15 Jul 1969
	27 Jul 1969	16 Aug 1969
	06 May 1972	07 May 1972
	17 May 1972	22 Jun 1972
	30 Jun 1972	16 Jul 1972
	27 Jul 1972	23 Aug 1972
	02 Sep 1972	19 Sep 1972
	29 Sep 1972	21 Oct 1972
	25 Oct 1972	26 Oct 1972
	03 Nov 1972	08 Dec 1972
	18 Dec 1972	31 Dec 1972



*Two squadron F/A-18C Hornets in flight over snow-covered mountains; note the bull on the tail of each aircraft, 1992.*

## VFA-81

### Lineage

Established as Attack Squadron SIXTY SIX (VA-66) on 1 July 1955.

Redesignated Fighter Squadron EIGHTY ONE (VF-81) on 1 July 1955, the same day it was established as VA-66.

Redesignated Attack Squadron EIGHTY ONE (VA-81) on 1 July 1959.

Redesignated Strike Fighter Squadron EIGHTY ONE (VFA-81) on 4 February 1988. The first squadron to be assigned the VA-66, VA-81 and VFA-81 designation.

### Squadron Insignia and Nickname

The squadron's first insignia was approved by CNO on 16 December 1955. Colors for the insignia were: a light blue background with an outer ring of alternating red and yellow sections, outlined in black; white cloud with black markings; black cougar with white markings and red eyes, mouth and claws; gray knight with black markings; red scarf; red and yellow helmet plume, shield and lance outlined in black; red scroll outlined in black, with yellow lettering.



The squadron's first insignia, the Crusaders, was approved in 1955.

A new insignia was approved by CNO on 21 November 1963. Color for this insignia were: a black background outlined in international orange; international orange mach wave design; orange scroll with black lettering.

A modification to the squadron's insignia was approved by CNO on 30 March 1988. Colors for this insignia are: a dark blue background outlined in



The squadron's second insignia was a stylized mach wave design, approved in 1963.



When the squadron was redesignated VFA a modification to its second insignia was approved for use in 1988.

orange; orange scrolls with black lettering; silver stars and stylized aircraft; gold aircraft contrails and an orange mach wave design.

Nickname: Crusaders, 1955–1963.

Sunliners, 1963–present.

### Chronology of Significant Events

**Nov–Dec 1956:** *Franklin D. Roosevelt* (CVA 42), with VF-81 embarked, was ordered to deploy and operate off the coast of Spain as a result of the Suez Canal crisis.

**Apr–May 1957:** VF-81, while deployed to the Mediterranean aboard *Lake Champlain* (CVA 39), operated off the coast of Lebanon during a crisis in Jordan.

**Oct 1961–Feb 1962:** VA-81 Det 45 deployed to the North Atlantic embarked in *Essex* (CVS 9). The detachment was part of CVSG-56, and with its A4D Skyhawks employing Sidewinder missiles, provided air cover for antisubmarine units embarked in *Essex*. The detachment was the first jet unit to function as part of an antisubmarine killer force.

**Sep 1969:** *John F. Kennedy* (CVA 67), with VA-81 embarked, were ordered to operate off the coast of Libya following a coup that overthrew the Libyan monarchy on 1 September 1969.

**2–5 Dec 1972:** The squadron's A-7E Corsair II aircraft conducted cross-deck operations with the British carrier HMS *Ark Royal*.

**Jul–Aug 1974:** The squadron operated from *Forrestal* (CVA 59) in the vicinity of Cyprus following a coup in that country and its invasion by Turkish forces. Surveillance and cover missions were flown by the squadron during the crisis.

**May–Jun 1981:** Embarked in *Forrestal*, VA-81 operated in the eastern Mediterranean following Israeli reprisal raids against Syrian missile batteries located in southern Lebanon.

**Aug 1981:** The squadron participated a Freedom of Navigation Exercise in the Gulf of Sidra. During this exercise two F-14 Tomcats from *Nimitz* (CVN 68) shot down two Libyan SU-22 Fitters on 18 August. Tensions escalated and VA-81 flew reconnaissance missions over potentially hostile Libyan ships.

**24 Mar 1986:** Following a Libyan SA-5 missile firing against U.S. naval aircraft operating in the Gulf of Sidra during a Freedom of Navigation exercise, VA-81 aircraft participated in a retaliatory strike against the missile site at Surt, Libya. Squadron aircraft acted as the decoy group for VA-83's HARM strike against the Libyan missile radar site.

**Aug–Dec 1990:** The squadron participated in Operation Desert Shield, the build-up of American and Allied forces to counter a threatened invasion of Saudi Arabia by Iraq and as part of an economic blockade of Iraq to force its withdrawal from Kuwait.



*A squadron F9F-8B in flight, 1957 (Courtesy Duane Kasulka Collection).*

### **Home Port Assignment**

<i>Location</i>	<i>Assignment Date</i>
NAS Oceana	01 Jul 1955
NAS Cecil Field	01 May 1966

### **Commanding Officers**

	<i>Date Assumed Command</i>
CDR Merle M. Hershey	01 Jul 1955
LCDR Robert Godman	30 Jul 1957
LCDR J. M. Scarborough	15 Aug 1958
CDR Lawrence Heyworth, Jr.	17 Oct 1958
CDR William P. Kiser	04 Nov 1959
CDR Richard E. Rumble	09 Nov 1960
CDR John N. Longfield	31 Oct 1961
CDR Robert B. Gohr	01 Dec 1962
CDR Grover K. Gregory	01 Oct 1963
CDR Nicholas A. Castruccio	06 Oct 1964
CDR Burton H. Sheperd	16 Oct 1965
CDR Edward A. Grunwald	20 Sep 1966
CDR Melville D. Cunningham	19 Sep 1967
CDR Lloyd M. Westphal	25 Sep 1968
CDR John J. Lahr	24 Jul 1969
CDR Richard J. Damico	12 Jun 1970
CDR Thomas C. Watson, Jr.	14 Apr 1971
CDR Jerry O. Tuttle	18 Feb 1972
CDR Kenneth A. Dickerson	18 Feb 1973
CDR Ralph E. Whitby	21 Feb 1974
CDR Robert V. Sallada	03 Mar 1975

### **Commanding Officers—Continued**

	<i>Date Assumed Command</i>
CDR Richard Birtwistle III	03 Jun 1976
CDR Jerry O. Yarborough	30 Jun 1977
CDR Philip H. Jacobs	14 Jul 1978
CDR James E. Killian	26 Jul 1979
CDR George J. Webb, Jr.	18 Dec 1980
CDR William C. Miller III	09 Mar 1982
CDR William E. Beaty III	Sep 1983
CDR Kenneth C. Cech	07 Mar 1985
CDR Jay M. Munninghoff	02 Jul 1986
CDR William N. Deaver, Jr.	04 Feb 1988
CDR Gerald L. Hoewing	11 May 1989
CDR Michael T. Anderson	29 Aug 1990

### **Aircraft Assignment**

<i>Type of Aircraft</i>	<i>Date Type First Received</i>
F9F-8	Aug 1955
F9F-8B	Apr 1956
A4D-2/A-4B*	04 Mar 1959
A-4E	03 Apr 1963
A-4C	Sep 1967
A-7E	May 1970
F/A-18C	30 Mar 1988

\* The A4D-2 designation was changed to A-4B in 1962.



*A squadron A-4C Skyhawk after completing a successful landing aboard John F. Kennedy (CVA 67) in 1969.*

**Major Overseas Deployments**

<i>Date of Departure</i>	<i>Date of Return</i>	<i>Air Wing</i>	<i>Carrier</i>	<i>Type of Aircraft</i>	<i>Area of Operation</i>
21 Jan 1957	27 Jul 1957	ATG-182	CVA 39	F9F-8/8B	Med
09 Jun 1958	08 Aug 1958	ATG-181	CVA 11	F9F-8	NorLant
28 Jan 1960	31 Aug 1960	CVG-8	CVA 59	A4D-2	Med
09 Feb 1961	25 Aug 1961	CVG-8	CVA 59	A4D-2	Med
03 Aug 1962	02 Mar 1963	CVG-8	CVA 59	A4D-2	Med
10 Jul 1964	13 Mar 1965	CVW-8	CVA 59	A-4E	Med
24 Aug 1965	07 Apr 1966	CVW-8	CVA 59	A-4E	Med
29 Sep 1966	20 May 1967	CVW-8	CVA 38	A-4E	Med
15 Nov 1967	04 Aug 1968	CVW-8	CVA 38	A-4C	Med
05 Apr 1969	21 Dec 1969	CVW-1	CVA 67	A-4C	Med
05 Jan 1971	02 Jul 1971	CVW-17	CVA 59	A-7E	Med
22 Sep 1972	06 Jul 1973	CVW-17	CVA 59	A-7E	Med
11 Mar 1974	11 Sep 1974	CVW-17	CVA 59	A-7E	Med
05 Mar 1975	22 Sep 1975	CVW-17	CV 59	A-7E	Med
04 Apr 1978	26 Oct 1978	CVW-17	CV 59	A-7E	Med/NorLant
27 Nov 1979	07 May 1980	CVW-17	CV 59	A-7E	Med
02 Mar 1981	15 Sep 1981	CVW-17	CV 59	A-7E	Med/NorLant
08 Jun 1982	16 Nov 1982	CVW-17	CV 59	A-7E	Med/IO
02 Apr 1984	20 Oct 1984	CVW-17	CV 60	A-7E	Med
26 Aug 1985	16 Apr 1986	CVW-17	CV 60	A-7E	Med/IO
05 Jun 1987	17 Nov 1987	CVW-17	CV 60	A-7E	Med
07 Aug 1990	28 Mar 1991	CVW-17	CV 60	F/A-18C	Med/Red Sea





*A formation of squadron A-7E Corsair IIs over NAS Cecil Field, Florida, in 1970.*

### **Air Wing Assignments**

<i>Air Wing</i>	<i>Tail Code</i>	<i>Assignment Date</i>
ATG-182	O	01 Jul 1955
CVG-17	R	Nov 1956
ATG-182	O/AN*	Dec 1956
ATG-181	AM	15 Mar 1958
CVG-8/CVW-8†	AJ	08 Aug 1958
CVW-1	AB	25 Aug 1968
COMFAIRJACKSON- VILLE		02 Mar 1970
COMLATWING 1		01 Jun 1970
CVW-17	AA	01 Aug 1970

\* The tail code was changed from O to AN in 1957. The effective date for this change was most likely the beginning of FY 58 (1 July 1957).

† CVG-8 was redesignated CVW-8 when Carrier Air Groups (CVG) were redesignated Carrier Air Wings (CVW) on 20 December 1963.

### **Unit Awards Received**

<i>Unit Award</i>	<i>Inclusive Dates Covering Unit Award</i>	
NAVE	01 Jul 1968	31 Dec 1969
	01 Jan 1973	30 Jun 1974
	01 Jan 1987	31 Dec 1987
NUC	10 Oct 1985	11 Oct 1985
	23 Mar 1986	29 Mar 1986
	17 Jan 1991	28 Feb 1991
MUC	28 Feb 1979	07 May 1980
NEM	05 Sep 1982	10 Sep 1982
	13 Oct 1982	05 Nov 1982
	20 Jan 1986	29 Mar 1986
SASM	22 Aug 1990	21 Sep 1990
	23 Oct 1990	09 Dec 1990
	06 Jan 1991	11 Mar 1991
KLM	17 Jan 1991	28 Feb 1991



*A squadron F/A-18C in flight, 1988.*

## VFA-82

### Lineage

Established as Attack Squadron EIGHTY TWO (VA-82) on 1 May 1967.

Redesignated Strike Fighter Squadron EIGHTY TWO (VFA-82) on 13 July 1987. The first squadron to be assigned the VA-82 and VFA-82 designations.



*This is the only insignia the squadron has used since it was established in 1967. When it was redesignated VFA in 1987, the squadron changed the ATKRON 82 acronym in the scroll to STRKFITRON 82.*

### Squadron Insignia and Nickname

The squadron's insignia was approved by CNO on 8 November 1967. Colors for the insignia are: a white background outlined in blue; blue shield outlined in black; brown eagle with white and black markings; yellow trident outlined in black; and a blue scroll with white lettering.

Nickname: Marauders, 1967-present.

### Chronology of Significant Events

**31 May 1968:** The squadron participated in its first combat operations, flying sorties over North Vietnam.

**Jul-Oct 1972:** The squadron participated in Operation Linebacker I, heavy air strikes against targets in North Vietnam.

**Dec 1972:** The squadron participated in Linebacker II operations, a more intensified version of Linebacker I operations.

**Jan 1980:** After the U.S. Embassy staff was taken hostage in Tehran, Iran, VA-82 departed Naples, Italy, embarked in *Nimitz* (CVN 68), enroute to the Indian Ocean via the Cape of Good Hope. This was the beginning of 144 consecutive days at sea for the squadron.

**Oct 1981:** Following the assassination of President Sadat of Egypt, *Nimitz*, with VA-82 embarked, was ordered to operate off the coast of Egypt.

**Jun 1985:** *Nimitz*, with VA-82 embarked, was ordered to operate off the coast of Lebanon due to the hijacking of TWA flight 847 by Arab radicals. The carrier and squadron remained on station until the release of the hostages in the latter part of July.

**Sep 1989:** Squadron aircraft flew support missions during the evacuation of the American Embassy in Beirut, Lebanon.

**12 Feb-7 Apr 1990:** VFA-82 was embarked in *Constellation* (CV 64) during its transit from the west coast to the east coast via the Straits of Magellan.



*A squadron A-7A Corsair II preparing to launch from Coral Sea (CVA 43) while deployed to Vietnam in 1969.*

### Home Port Assignments

Location	Assignment Date
NAS Cecil Field	01 May 1967

### Commanding Officers

	Date Assumed Command
CDR J. A. Burnett	20 Jul 1967
CDR J. E. Jones	05 Sep 1967
CDR D. P. Thomas	08 Jan 1969
CDR E. M. Clemens	01 Dec 1969
CDR James M. Gleim	30 Oct 1970
CDR Thomas P. Scott	22 Oct 1971
CDR Donald M. Sumner	02 Sep 1972
CDR Jerry C. Breast	25 Oct 1973
CDR Peter R. Schoeffel	13 Aug 1974
CDR Douglas P. Dunbar, Jr.	04 Aug 1975
CDR Thomas A. Mercer	04 Nov 1976
CDR Donald B. Hunt	16 Nov 1977
CDR David M. Gist	Jan 1979
CDR Robert B. Newell, Jr.	12 Mar 1980
CDR Dan H. Ryder	01 May 1981
CDR David H. Finney	14 Jul 1982
CDR Dennis J. Carroll	23 Feb 1984
CDR Robert J. Sanderson	06 Jul 1985
CDR Gerald A. Pike	23 Feb 1987
CDR Richard A. Eason	02 Sep 1988
CDR James Ross	02 Feb 1990

### Aircraft Assignment

Type of Aircraft	Date Type First Received
A-7A	Jun 1967
A-7E	08 Sep 1970
A-7C	Apr 1972
A-7E	Nov 1974
F/A-18C	09 Nov 1987



*Two squadron A-7E Corsair IIs in flight, showing the low-visibility paint scheme, 1987.*

### **Major Overseas Deployments**

<i>Date of Departure</i>	<i>Date of Return</i>	<i>Air Wing</i>	<i>Carrier</i>	<i>Type of Aircraft</i>	<i>Area of Operation</i>
10 Apr 1968	16 Dec 1968	CVW-6	CVA 66	A-7A	WorldCruise/ Vietnam
23 Sep 1969	01 Jul 1970	CVW-15	CVA 43	A-7A	WestPac/Vietnam
06 Jul 1971	16 Dec 1971	CVW-8	CVA 66	A-7E	Med
05 Jun 1972	24 Mar 1973	CVW-8	CVA 66	A-7C	WestPac/Vietnam
03 Jan 1974	03 Aug 1974	CVW-8	CVA 66	A-7C	Med
06 Sep 1974	12 Oct 1974	CVW-8	CVA 66	A-7C	NorLant
16 Jul 1975	24 Sep 1975	CVW-8	CVN 68	A-7E	Carib/NorLant
07 Jul 1976	07 Feb 1977	CVW-8	CVN 68	A-7E	Med
01 Dec 1977	20 Jul 1978	CVW-8	CVN 68	A-7E	Med/NorLant
10 Sep 1979	26 May 1980	CVW-8	CVN 68	A-7E	Med/SoLant/IO
29 Aug 1980	17 Oct 1980	CVW-8	CVN 68	A-7E	NorLant
03 Aug 1981	12 Feb 1982	CVW-8	CVN 68	A-7E	Med
10 Nov 1982	20 May 1983	CVW-8	CVN 68	A-7E	Carib/Med
08 Mar 1985	04 Oct 1985	CVW-8	CVN 68	A-7E	Carib/Med
15 Aug 1986	16 Oct 1986	CVW-8	CVN 68	A-7E	NorLant
30 Dec 1986	26 Jul 1987	CVW-8	CVN 68	A-7E	Med/SoLant/ West Coast
08 Feb 1989	03 Apr 1989	CVW-1	CV 66	F/A-18C	Carib/NorLant
11 May 1989	10 Nov 1989	CVW-1	CV 66	F/A-18C	Med/IO
28 Dec 1990	18 Apr 1991	CVW-1	CV 66	F/A-18C	Med/Red Sea/ Persian Gulf

**Air Wing Assignments**

<i>Air Wing</i>	<i>Tail Code</i>	<i>Assignment Date</i>
COMFAIRJACKSON-VILLE*		01 Sep 1967
CVW-6	AE	01 Dec 1967
CVW-15	NL	1969
COMFAIRJACKSON-VILLE		01 Jul 1970
CVW-8	AJ	Apr 1971
COMLATWING 1		01 Sep 1987
CVW-1	AB	1988

\* Between 1 May and 1 September 1967 the squadron was under the administrative control of VA-174 during its training in the A-7 Corsair II.

**Unit Awards Received—Continued**

<i>Unit Award</i>	<i>Inclusive Dates Covering Unit Award</i>
	17 Aug 1968
	12 Sep 1968
	27 Sep 1968
	30 Oct 1968
	26 Oct 1969
	18 Nov 1969
	22 Dec 1969
	19 Jan 1970
	17 Feb 1970
	09 Mar 1970
	19 Mar 1970
	11 Apr 1970
	28 Apr 1970
	01 Jun 1970
	02 Jul 1972
	04 Jul 1972
	11 Jul 1972
	24 Jul 1972
	10 Aug 1972
	28 Aug 1972
	06 Sep 1972
	07 Oct 1972
	11 Oct 1972
	12 Oct 1972
	20 Oct 1972
	01 Dec 1972
	09 Dec 1972
	27 Dec 1972
	09 Jan 1973
	02 Feb 1973
	12 Feb 1973
	16 Feb 1973
	21 Feb 1973
	25 Feb 1973
	10 Dec 1969
	11 Dec 1969
	27 Oct 1969
	01 Jun 1970
	14 Jul 1972
	20 Feb 1973
	14 Jan 1980
	14 May 1980
	05 Dec 1982
	31 Dec 1982
	21 Jan 1983
	13 Feb 1983
	18 Feb 1983
	24 Feb 1983
	19 Mar 1983
	21 Mar 1983
	18 Apr 1983
	22 Apr 1983
	15 Jan 1991
	03 Apr 1991
	17 Jan 1991
	28 Feb 1991

**Unit Awards Received**

<i>Unit Award</i>	<i>Inclusive Dates Covering Unit Award</i>
NAVE	01 Jul 1975
	30 Sep 1976
	01 Jan 1989
	31 Dec 1989
NUC	12 May 1968
	20 Nov 1968
	23 Jan 1980
	01 May 1980
	17 Jan 1991
	07 Feb 1991
RVNGC	30 May 1968
	02 Jun 1968
	29 Sep 1968
	10 Oct 1968
	12 Oct 1968
	17 Oct 1968
VNSM	29 May 1968
	28 Jun 1968
	06 Jul 1968
	03 Aug 1968



*A squadron F/A-18C Hornet in flight, 1987.*

## VFA-83

### Lineage

Reserve Fighter Squadron NINE HUNDRED SIXTEEN (VF-916) called to active duty on 1 February 1951.

Redesignated Fighter Squadron EIGHTY THREE (VF-83) on 4 February 1953.

Redesignated Attack Squadron EIGHTY THREE (VA-83) on 1 July 1955.

Redesignated Strike Fighter Squadron EIGHTY THREE (VFA-83) on 3 March 1988. The first squadron to be assigned the VA-83 and VFA-83 designations.



The squadron's first insignia, the bull with machine guns, was approved in 1950.

mouth and ring around the eye were pink.

A new squadron insignia was approved by CNO on 12 April 1957. Colors for the Rampager insignia are: a light blue background outlined in gold; blue scroll outlined in black with black lettering; white ram's head with black markings; red eyes; and white horns with yellow, green and black markings.



The squadron adopted the ram head insignia in 1957 and has used this design for the past four decades.

### Squadron Insignia and Nickname

The squadron's first insignia was approved by CNO on 16 May 1950. Colors for the insignia were: a yellow background; black bull with brown hair around the horns; white horns with light blue shading; the teeth, eye and smoke were white; the nose,

Nickname: The Roaring Bulls, 1950–1953.

Rampagers, 1957 to present.

### Chronology of Significant Events

12 Mar 1956: VA-83, equipped with F7U-3M Cutlass aircraft and Sparrow I missiles, departed Norfolk, Virginia, embarked in *Intrepid* (CVA 11), for deployment to the Mediterranean Sea. This was the first overseas deployment of a naval missile squadron.

Dec 1957: The squadron was the first fleet squadron to receive the A4D-2 Skyhawk. This version of the

Skyhawk was the first to be equipped with an inflight refueling capability.

**Jul–Aug 1958:** Following continued civil violence in Lebanon, VA-83 operating from *Essex* (CVA 9) flew sorties during the U.S. Marine Corps landings in Lebanon to support the Lebanese government and protect American lives. During the squadron's more than 500 sorties, two of its aircraft were hit by hostile small arms fire during road reconnaissance missions, no casualties were sustained.

**Sep 1958:** On 23 August 1958 the People's Republic of China began shelling the Quemoy Islands held by the Republic of China. *Essex*, with VA-83 embarked, was ordered to transit the Suez Canal and augment the 7th Fleet forces in the Taiwan Straits. During September the squadron conducted flight operations while operating in the Taiwan Straits.

**Aug 1962:** A squadron A4D-2N Skyhawk cross-decked on the British carrier HMS *Hermes*.

**Sep 1969:** *John F. Kennedy* (CVA 67), with VA-83 embarked, was ordered to operate off the coast of Libya following a coup that overthrew the Libyan monarchy on 1 September 1969.

**Jul–Aug 1974:** The squadron operated from *Forrestal* (CVA 59) in the vicinity of Cyprus following a coup in that country and its invasion by Turkish forces.

**May–Jun 1981:** Embarked in *Forrestal*, VA-83 operated in the eastern Mediterranean following Israeli reprisal raids against Syrian missile batteries located in southern Lebanon.

**Aug 1981:** The squadron participated in a Freedom of Navigation Exercise in the Gulf of Sidra. During this exercise two F-14 Tomcats from *Nimitz* (CVN 68) shot down two Libyan SU-22 Fitters on 18 August. Tensions escalated and VA-83 flew reconnaissance missions over potentially hostile Libyan ships.

**24 Mar 1986:** Following a Libyan SA-5 missile firing against U.S. naval aircraft operating in the Gulf of Sidra during a Freedom of Navigation exercise, VA-83 aircraft participated in a retaliatory strike against the missile site at Surt, Libya. Squadron aircraft fired HARMs against the Libyan missile radar site. This was the first use of the AGM-88 HARM missile in combat.

**Aug–Dec 1990:** The squadron participated in Operation Desert Shield, the build-up of American and Allied forces to counter a threatened invasion of Saudi Arabia by Iraq and as part of an economic blockade of Iraq to force its withdrawal from Kuwait.

### Home Port Assignments

Location	Assignment Date
NAS Jacksonville	01 Feb 1951
NAAS Oceana/NAS Oceana*	Sep 1951
NAS Cecil Field	15 Jun 1966

\* NAAS Oceana was redesignated NAS Oceana on 1 April 1952.



*A squadron F7U-3M Cutlass preparing for a launch from Intrepid (CVA 11) in 1956.*

**Commanding Officers**

	<i>Date Assumed Command</i>
LCDR A. J. Fecke	Apr 1950
CDR W. R. Sisley	16 Dec 1952
CDR R. J. Swanson	Dec 1953
CDR H. E. Vita	28 Jan 1955
CDR James L. Holloway III	12 Sep 1956
CDR Albert H. Vito, Jr.	05 Dec 1958
CDR David S. Stear	15 Jan 1960
CDR James W. Nance	02 Dec 1960
CDR James Spargo	15 Dec 1961
CDR A. H. Cummings	10 Dec 1962
CDR R. G. Thomson, Jr.	20 Dec 1963
CDR F. B. Bromley	19 Dec 1964
CDR E. S. Carver	07 Dec 1965
CDR G. F. Brummitt	08 Dec 1966
CDR D. M. Trimble	Nov 1967
CDR F. J. Almberg	Sep 1968
CDR Theodore C. Casimes	02 Sep 1969
CDR William M. Shewchuk	04 Jan 1971
CDR D. B. Gilbert	12 Jan 1972
CDR J. E. Craig, Jr.	03 Jan 1973
CDR G. A. Appelhof	14 Feb 1974
CDR A. H. Henderson	15 May 1975
CDR John M. Waples	05 Aug 1976
CDR Robert J. Naughton	27 Nov 1977
CDR R. E. Wolf	28 Feb 1979
CDR Austin E. Chapman	29 May 1980

**Commanding Officers—Continued**

	<i>Date Assumed Command</i>
CDR Douglas J. Bradt	21 Jan 1982
CDR W. E. Franson	28 Apr 1983
CDR S. F. Bloyer	10 Sep 1984
CDR R. J. Nibe	24 Apr 1986
CDR Terry A. Miller	28 Sep 1987
CDR Michael W. Longworth	03 Jun 1988
CDR Dennis M. Gillespie	30 Nov 1989

**Aircraft Assignment**

<i>Type of Aircraft</i>	<i>Date Type First Received</i>
F4U-4	Feb 1951
F9F-2	Dec 1951
F8F-2	May 1952
F9F-5	Sep 1952
F7U-3	Aug 1954
F7U-3M	Apr 1955
A4D-1	Mar 1957
A4D-2	15 Dec 1957
A4D-2N/A-4C*	14 Sep 1960
A-4E	May 1963
A-4C	Aug 1967
A-7E	19 Jun 1970
F/A-18C	25 Apr 1988

\* The A4D-2N designation was changed to A-4C in 1962.



*A squadron A4D-2N (A-4C) Skyhawk, circa 1960–1962.*

### Major Overseas Deployments

<i>Date of Departure</i>	<i>Date of Return</i>	<i>Air Wing</i>	<i>Carrier</i>	<i>Type of Aircraft</i>	<i>Area of Operation</i>
26 Apr 1953	21 Oct 1953	CVG-8	CVA 43	F9F-5	Med
12 Mar 1956	05 Sep 1956	CVG-8	CVA 11	F7U-3M	Med
02 Feb 1958	17 Nov 1958	ATG-201	CVA 9	A4D-2	Med/IO/WestPac
28 Jan 1960	31 Aug 1960	CVG-8	CVA 59	A4D-2	Med
09 Feb 1961	25 Aug 1961	CVG-8	CVA 59	A4D-2N	Med
03 Aug 1962	02 Mar 1963	CVG-8	CVA 59	A-4C	Med
10 Jul 1964	13 Mar 1965	CVW-8	CVA 59	A-4E	Med
24 Aug 1965	07 Apr 1966	CVW-8	CVA 59	A-4E	Med
29 Sep 1966	20 May 1967	CVW-8	CVA 38	A-4E	Med
15 Nov 1967	04 Aug 1968	CVW-8	CVA 38	A-4C	Med
05 Apr 1969	21 Dec 1969	CVW-1	CVA 67	A-4C	Med
05 Jan 1971	02 Jul 1971	CVW-17	CVA 59	A-7E	Med
22 Sep 1972	06 Jul 1973	CVW-17	CVA 59	A-7E	Med
11 Mar 1974	11 Sep 1974	CVW-17	CVA 59	A-7E	Med
05 Mar 1975	22 Sep 1975	CVW-17	CV 59	A-7E	Med
04 Apr 1978	26 Oct 1978	CVW-17	CV 59	A-7E	Med/NorLant
27 Nov 1979	07 May 1980	CVW-17	CV 59	A-7E	Med
02 Mar 1981	15 Sep 1981	CVW-17	CV 59	A-7E	Med/NorLant
08 Jun 1982	16 Nov 1982	CVW-17	CV 59	A-7E	Med/IO
02 Apr 1984	20 Oct 1984	CVW-17	CV 60	A-7E	Med
26 Aug 1985	16 Apr 1986	CVW-17	CV 60	A-7E	Med/IO
05 Jun 1987	17 Nov 1987	CVW-17	CV 60	A-7E	Med
07 Aug 1990	28 Mar 1991	CVW-17	CV 60	F/A-18C	Med/Red Sea

### Air Wing Assignments

<i>Air Wing</i>	<i>Tail Code</i>	<i>Assignment Date</i>
CVG-8	E	Apr 1951
ATG-201	AP	15 Oct 1957
CVG-8/CVW-8*	AJ	18 Nov 1958
CVW-1	AB	25 Aug 1968
COMFAIRJACKSON-VILLE		02 Mar 1970

### Air Wing Assignments—Continued

<i>Air Wing</i>	<i>Tail Code</i>	<i>Assignment Date</i>
COMLATWING 1		01 Jun 1970
CVW-17	AA	01 Aug 1970

\* CVG-8 was redesignated CVW-8 when Carrier Air Groups (CVG) were redesignated Carrier Air Wings (CVW) on 20 December 1963.



*A formation of squadron A-7E Corsair IIs in flight during their deployment to the Med aboard Forrestal (CV 59) in 1974.*

**Unit Awards Received**

<i>Unit Award</i>	<i>Inclusive Dates Covering Unit Award</i>	
NAVE	01 Jul 1960	30 Jun 1961
	01 Jul 1961	30 Jun 1962
	01 Jan 1990	31 Dec 1990
AFEM	16 Jul 1958	01 Aug 1958
	11 Aug 1958	20 Aug 1958
	16 Sep 1958	27 Sep 1958
NEM	05 Sep 1982	10 Sep 1982
	13 Oct 1982	05 Nov 1982

**Unit Awards Received—Continued**

<i>Unit Award</i>	<i>Inclusive Dates Covering Unit Award</i>	
NUC	20 Jan 1986	29 Mar 1986
	10 Oct 1985	11 Oct 1985
	23 Mar 1986	29 Mar 1986
SASM	17 Jan 1991	28 Feb 1991
	22 Aug 1990	21 Sep 1990
	23 Oct 1990	09 Dec 1990
KLM	06 Jan 1991	11 Mar 1991
	17 Jan 1991	28 Feb 1991



*A squadron F/A-18C Hornet over the bombing range in Florida.*



## VFA-86

### Lineage

Reserve Fighter Squadron NINE HUNDRED TWENTY ONE (VF-921) called to active duty on 1 February 1951.

Redesignated Fighter Squadron EIGHTY FOUR (VF-84) on 4 February 1953.

Redesignated Attack Squadron EIGHTY SIX (VA-86) on 1 July 1955.

Redesignated Strike Fighter Squadron EIGHTY SIX (VFA-86) on 15 July 1987. The second squadron to be assigned the VA-86 designation and the first squadron to be assigned the VFA-86 designation.



*This was the first insignia approved for and used by the squadron.*

with black markings; and a white machine gun and missile with black markings.

A new insignia was approved by CNO on 7 April 1954. Colors for the top hat and snake insignia are: a black background outlined in white and black; gold snake with black markings, white fangs, red eyes and tongue; black top hat with white markings; and a black cane outlined in white with gold markings at the top and bottom.

Nickname: Side-winders, 1955-present.

### Squadron Insignia and Nickname

The squadron's first insignia was approved by CNO on 6 August 1951. Colors for the insignia were: a blue background; red bird with black markings, yellow beak and feet outlined in black and a white eye; yellow aviator wings and anchor



*The top hat and snake became the squadron's second insignia in 1954 and has become a well-known design.*

### Chronology of Significant Events

**29 Jun–2 Jul 1953:** VF-84 was embarked in *Antietam* (CVA 36) and operated with the British Royal Navy, demonstrating flight operations from the carrier's new angled deck.

**7 Jan 1961:** The squadron's commanding officer, Commander J. W. Shuff, was killed in an aircraft accident while the squadron was deployed to the Mediterranean.

**Apr 1961:** The squadron operated from *Independence* (CVA 62) in an area south of Guantanamo Bay, Cuba, during the Bay of Pigs, the unsuccessful invasion of Cuba by American supported Cuban exiles.

**Nov 1962:** The squadron embarked in *Lexington* (CVS 16) during the Cuban Missile Crisis and operated off the coast of Jacksonville, Florida, on call and available for operations in the Caribbean.

**Apr–May 1963:** The squadron provided detachments for operation aboard *Randolph* (CVS 15), *Essex* (CVS 9) and *Wasp* (CVS 18). The detachment's A-4C Skyhawks were equipped with Sidewinder missiles and used to provide the ASW carriers with an antiair warfare capability.

**1 Jul 1965:** The squadron conducted its first combat mission, flying against targets in South Vietnam.

**11 Oct 1967:** Squadron aircraft and pilots participated in naval gun spotting missions in support of *New Jersey's* (BB 62) shore bombardment role in Vietnam.

**Jul–Oct 1972:** Squadron aircraft participated in Operation Linebacker I, heavy air strikes against targets in North Vietnam.

**Dec 1972:** The squadron participated in Linebacker II operations, a more intensified version of Linebacker I operations.

**Jan 1980:** After the U.S. Embassy staff was taken hostage in Tehran, Iran, VA-86 departed Naples, Italy, embarked in *Nimitz* (CVN 68), enroute to the Indian Ocean via the Cape of Good Hope. This was the beginning of 144 consecutive days at sea for the squadron.

**Aug 1981:** Embarked in *Nimitz*, the squadron participated in a Freedom of Navigation Exercise in the Gulf of Sidra. During this exercise two F-14 Tomcats from *Nimitz* were fired upon by two Libyan SU-22 Fitters on 18 August. The F-14's returned fire and shot down the two aircraft. Tensions escalated and VA-86 flew refueling and reconnaissance missions over potentially hostile Libyan ships.

**Oct 1981:** Following the assassination of President Sadat of Egypt, *Nimitz*, with VA-86 embarked, was ordered to operate off the coast of Egypt.

**Feb 1983:** Following hostile threats against Sudan by Libya, *Nimitz*, with VA-86 embarked, operated off the coast bordering Libya and Egypt.

**Jun 1985:** *Nimitz*, with VA-86 embarked, was ordered to operate off the coast of Lebanon due to the hijacking of TWA flight 847 by Arab radicals. The carrier and squadron remained on station until the release of the hostages in the latter part of July.

**Jan–Feb 1987:** VA-86, embarked in *Nimitz*, operated off the coast of Lebanon after three U.S. citizens were taken hostage from the American University in Beirut.

*A squadron F4U-4 Corsair prepares to launch from Tarawa (CV 40), September 1951 (Courtesy Robert Lawson Collection).*



**Home Port Assignments**

<i>Location</i>	<i>Assignment Date</i>
NAS St. Louis	*
NAS Jacksonville	28 Mar 1951
NAS Oceana	11 Jun 1952
NAS Cecil Field	15 Mar 1966

\* As a reserve squadron, it was assigned to NAS St. Louis prior to a recall to active duty in 1951.

**Commanding Officers**

	<i>Date Assumed Command</i>
LT L. H. Pulford	1947*
LCDR Harold L. Buell	Jul 1952
LCDR Herbert V. Ladley	Jul 1953
CDR Chester W. Gates, Jr.	May 1955
LCDR Grant Boice	Sep 1956
LCDR Jack H. Robcke (acting)	Sep 1957
CDR William A. Schroeder, Jr.	24 Sep 1957
CDR Rodney F. Schall	12 Mar 1959
CDR John W. Shuff, Jr.	29 Feb 1960
CDR Sam Rorex, Jr.	07 Jan 1961
CDR Richard J. McAndrew	12 Jan 1962
CDR F. B. Koch	21 Dec 1962
CDR Wilbur J. Burgin	06 Dec 1963
CDR William F. Sallada	11 Dec 1964
CDR William W. Bowers	15 Nov 1965
CDR C. R. Long	16 Nov 1966
CDR J. E. Russ	30 Nov 1967
CDR D. E. Gordon	10 Jan 1969
CDR Standley H. Block	21 Jan 1970
CDR Grant Augustine III	15 Jan 1971
CDR William D. Yonke	28 Jan 1972
CDR Benjamin F. Short	06 Dec 1972
CDR Duane O. Schumacher	14 Dec 1973
CDR Perry W. Gard III	07 Mar 1975
CDR Leighton W. Smith, Jr.	22 Apr 1976

**Commanding Officers—Continued**

	<i>Date Assumed Command</i>
CDR Herbert W. Taylor	02 Jun 1977
CDR Bernard J. Smith	02 Jun 1978
CDR Virgil F. Jackson, Jr.	19 Nov 1979
CDR John P. Gay	12 Feb 1981
CDR Charles S. Abbot	23 Jun 1982
CDR Ralph J. Castor	16 Jun 1983
CDR John L. Fitzpatrick	29 Jan 1985
CDR John M. Johnson	05 Jun 1986
CDR Howard A. Petrea	28 Jan 1988
CDR Ted J. Venable	1989
CDR Matthew G. Moffit	06 Nov 1990

\* Lieutenant Pulford was commanding officer of VF-921 during its reserve status and continued as its commanding officer when it was called to active duty.



*A squadron F9F-5 Panther on the deck of Antietam (CVA 36) during her cruise in 1953.*



*Squadron officers and their F7U-3M Cutlass in the background, November 1955. Bottom row, left to right: Lt. (jg) W. M. Austin, Ens. C. R. Hill, Ens. S. J. Kreider, Ens. D. C. Gandee, Ens. W. E. Dennison, Lt. A. L. Kivien, Lt. (jg) J. F. McNerney, Lt. (jg) G. W. Lenox. Top row, left to right: Lt. (jg) J. T. Bucy, Cdr. C. W. Gates, Jr., Lt. (jg) D. A. Kueth, Lt. (jg) R. C. Barron, Lt. (jg) T. B. Green, Lt. (jg) H. W. Hall, Lt. (jg) R. L. Stevenson, and Ens. G. L. Atkinson.*

### **Aircraft Assignment**

<i>Type of Aircraft</i>	<i>Date Type First Received</i>
F4U-4	Feb 1951
F8F-2	18 Jun 1952
F9F-5	Sep 1952
F7U-3M	Jun 1955
A4D-1	26 May 1957
A4D-2	24 Dec 1957
A4D-2N/A-4C*	Sep 1962

### **Aircraft Assignment—Continued**

<i>Type of Aircraft</i>	<i>Date Type First Received</i>
A-4E	28 Apr 1964
A-7A	Feb 1967
A-7E	01 Oct 1970
A-7C	Apr 1972
A-7E	14 Nov 1974
F/A-18C	18 Nov 1987

\* The A4D-2N designation was changed to A-4C in 1962.

### **Major Overseas Deployments**

<i>Date of Departure</i>	<i>Date of Return</i>	<i>Air Wing</i>	<i>Carrier</i>	<i>Type of Aircraft</i>	<i>Area of Operation</i>
28 Nov 1951	11 Jun 1952	CVG-8	CV 40	F4U-4	Med
11 Jun 1953	21 Jul 1953	*	CV 36	F9F-5	NorLant
28 Sep 1954	22 Apr 1955	CVG-8	CVA 39	F9F-5	Med
02 Sep 1958	12 Mar 1959	CVG-7	CVA 15	A4D-2	Med
04 Aug 1960	03 Mar 1961	CVG-7	CVA 62	A4D-2	Med
04 Aug 1961	19 Dec 1961	CVG-7	CVA 62	A4D-2	Med
19 Apr 1962	27 Aug 1962	CVG-7	CVA 62	A4D-2	Med
06 Aug 1963	04 Mar 1964	CVG-7	CVA 62	A-4C	Med
08 Sep 1964	05 Nov 1964	CVW-7	CVA 62	A-4E	NorLant/Med

**Major Overseas Deployments—Continued**

<i>Date of Departure</i>	<i>Date of Return</i>	<i>Air Wing</i>	<i>Carrier</i>	<i>Type of Aircraft</i>	<i>Area of Operation</i>
10 May 1965	13 Dec 1965	CVW-7	CVA 62	A-4E	WestPac/Vietnam
13 Jun 1966	01 Feb 1967	CVW-7	CVA 62	A-4E	Med
10 Apr 1968	16 Dec 1968	CVW-6	CVA 66	A-7A	World Cruise/ Vietnam
23 Sep 1969	01 Jul 1970	CVW-15	CVA 43	A-7A	WestPac/Vietnam
06 Jul 1971	16 Dec 1971	CVW-8	CVA 66	A-7E	Med
05 Jun 1972	24 Mar 1973	CVW-8	CVA 66	A-7C	WestPac/Vietnam
03 Jan 1974	03 Aug 1974	CVW-8	CVA 66	A-7C	Med
06 Sep 1974	12 Oct 1974	CVW-8	CVA 66	A-7C	NorLant
16 Jul 1975	24 Sep 1975	CVW-8	CVN 68	A-7E	Carib/NorLant
07 Jul 1976	07 Feb 1977	CVW-8	CVN 68	A-7E	Med
01 Dec 1977	20 Jul 1978	CVW-8	CVN 68	A-7E	Med/NorLant
10 Sep 1979	26 May 1980	CVW-8	CVN 68	A-7E	Med/SoLant/IO
29 Aug 1980	17 Oct 1980	CVW-8	CVN 68	A-7E	NorLant
03 Aug 1981	12 Feb 1982	CVW-8	CVN 68	A-7E	Med
10 Nov 1982	20 May 1983	CVW-8	CVN 68	A-7E	Carib/Med
08 Mar 1985	04 Oct 1985	CVW-8	CVN 68	A-7E	Carib/Med
15 Aug 1986	16 Oct 1986	CVW-8	CVN 68	A-7E	NorLant
30 Dec 1986	26 Jul 1987	CVW-8	CVN 68	A-7E	Med/SoLant/West Coast
08 Feb 1989	03 Apr 1989	CVW-1	CV 66	F/A-18C	Carib/NorLant
11 May 1989	10 Nov 1989	CVW-1	CV 66	F/A-18C	Med/IO
28 Dec 1990	18 Apr 1991	CVW-1	CV 66	F/A-18C	Med/RedSea/ Persian Gulf

\* VF-84, VC-4 and VS-27 deployed aboard *Antietam* (CVA 36). The carrier did not have an air group embarked.



*Squadron A-4E Skyhawks at NAS Oceana in 1965. Cdr. W. W. Bowers is climbing out of the aircraft. Note the Tonkin Gulf Yacht Club insignia on the forward part of the fuselage and the combat sortie mission marks on the fuselage just aft of the jet intake.*

**Air Wing Assignments**

<i>Air Wing</i>	<i>Tail Code</i>	<i>Assignment Date</i>
CVG-8	E	09 Apr 1951
ATG-181	I/AM*	Jul 1955
CVG-7/CVW-7†	AG	15 Jan 1958
CVW-6	AE	16 Oct 1967
CVW-15	NL	1969
COMFAIRJACKSON- VILLE		01 Jul 1970

**Air Wing Assignments—Continued**

<i>Air Wing</i>	<i>Tail Code</i>	<i>Assignment Date</i>
CVW-8	AJ	Jan 1971
COMLATWING 1		01 Sep 1987
CVW-1	AB	1988

\* The tail code was changed from I to AM in 1957. The effective date for this change was most likely the beginning of FY 58 (1 July 1957).

† CVG-7 was redesignated CVW-7 when Carrier Air Groups (CVG) were redesignated Carrier Air Wings (CVW) on 20 December 1963.



*A formation of squadron A-7E Corsair IIs, circa 1978.*

**Unit Awards Received**

<i>Unit Award</i>	<i>Inclusive Dates Covering Unit Award</i>	
NAVE	01 Jul 1962	30 Jun 1963
	01 Jul 1963	30 Jun 1964
	01 Jan 1982	31 Dec 1982
	01 Jan 1985	31 Dec 1985
AFEM	24 Sep 1958	26 Sep 1958
	15 Jun 1965	
	29 Jun 1965	03 Jul 1965
MUC	10 Dec 1969	11 Dec 1969
	27 Oct 1969	01 Jun 1970

**Unit Awards Received—Continued**

<i>Unit Award</i>	<i>Inclusive Dates Covering Unit Award</i>	
NEM	14 Jul 1972	20 Feb 1973
	04 Aug 1981	20 May 1983
	19 Apr 1961	29 Apr 1961
	14 Jan 1980	14 May 1980
	05 Dec 1982	31 Dec 1982
	21 Jan 1983	13 Feb 1983
	18 Feb 1983	24 Feb 1983
	19 Mar 1983	21 Mar 1983
	18 Apr 1983	22 Apr 1983

**Unit Awards Received—Continued**

<i>Unit Award</i>	<i>Inclusive Dates Covering Unit Award</i>	
NUC	05 Jun 1965	21 Nov 1965
	12 May 1968	20 Nov 1968
	23 Jan 1980	01 May 1980
	17 Jan 1991	07 Feb 1991
RVNGC	21 Oct 1965	
	23 Oct 1965	
	25 Oct 1965	02 Nov 1965
	09 Nov 1965	10 Nov 1965
	30 May 1968	02 Jun 1968
	20 Sep 1968	
	10 Oct 1968	12 Oct 1968
VNSM	17 Oct 1968	
	04 Jul 1965	09 Aug 1965
	25 Aug 1965	21 Sep 1965
	14 Oct 1965	12 Nov 1965
	29 May 1968	28 Jun 1968
	06 Jul 1968	03 Aug 1968
	17 Aug 1968	12 Sep 1968

**Unit Awards Received—Continued**

<i>Unit Award</i>	<i>Inclusive Dates Covering Unit Award</i>	
SASM	27 Sep 1968	30 Oct 1968
	26 Oct 1969	18 Nov 1969
	22 Dec 1969	19 Jan 1970
	17 Feb 1970	09 Mar 1970
	19 Mar 1970	11 Apr 1970
	28 Apr 1970	01 Jun 1970
	02 Jul 1972	04 Jul 1972
	11 Jul 1972	24 Jul 1972
	10 Aug 1972	28 Aug 1972
	06 Sep 1972	07 Oct 1972
	11 Oct 1972	12 Oct 1972
	20 Oct 1972	01 Dec 1972
	09 Dec 1972	27 Dec 1972
	09 Jan 1973	02 Feb 1973
	12 Feb 1973	16 Feb 1973
	21 Feb 1973	25 Feb 1973
KLM	15 Jan 1991	03 Apr 1991
	17 Jan 1991	28 Feb 1991



*A squadron F/A-18C in flight, 1992.*

## VFA-87

### Lineage

Established as Attack Squadron EIGHTY SEVEN (VA-87) on 1 February 1968.

Redesignated Strike Fighter Squadron EIGHTY SEVEN (VFA-87) on 1 May 1986. The first squadron to be assigned the VA-87 and VFA-87 designations.

### Squadron Insignia and Nickname

The squadron's insignia was approved by CNO on 29 July 1968. Colors for the insignia are: a red back



*The squadron's Golden Warrior insignia was approved for use in 1968. When the squadron was redesignated VFA, the designation in the scroll was changed from ATKRON 87 to STRKFITRON 87 or VFA-87.*

ground outlined in yellow and black; the Indian, war bonnet, spear and pony are yellow; and the arrow-head is black.

Nickname: Golden Warriors, 1968-present.

### Chronology of Significant Events

**4 Mar 1969:** The squadron flew its first combat missions, striking enemy targets in South Vietnam.

**Apr 1969:** Following the shoot down of a Navy EC-121 aircraft by the North Koreans, *Ticonderoga* (CVA 14), with VA-87 embarked, was ordered to the Sea of Japan.

**Oct–Nov 1973:** VA-87, embarked in *Franklin D. Roosevelt* (CVA 42), operated in the vicinity of Crete in response to the Arab-Israeli War.

**Jun–Jul 1976:** The American Ambassador to Lebanon was assassinated on 13 June and *America* (CV 66), with VA-87 embarked, operated in the vicinity of Lebanon. Squadron aircraft flew support missions during the evacuation of non-combatants from that country.

**May 1981:** *Independence* (CV 62), with VA-87 embarked, following its transit of the Suez Canal, remained on station in the eastern Mediterranean due to the crisis between Israel and Syria following Israeli raids against Syrian surface-to-air missile sites in Lebanon.

**25 Oct–1 Nov 1983:** In response to continued political strife and the need to protect and evacuate Americans from the island country of Grenada, VA-87 aircraft flew combat close air support missions during Operation Urgent Fury, the landing of U.S. Marines and Army rangers on the island.

**4 Dec 1983:** In response to hostile fire against U.S. reconnaissance aircraft from Syrian positions in Lebanon, VA-87 aircraft participated in a coordinated strike against Syrian radar, communications and artillery positions overlooking the Multi-National Peacekeeping Forces. All squadron aircraft completed their mission and returned to the carrier.

*A flight of squadron A-7B Corsair IIs in 1971.*



**Home Port Assignments**

<i>Location</i>	<i>Assignment Date</i>
NAS Cecil Field	01 Feb 1968

**Commanding Officers**

	<i>Date Assumed Command</i>
CDR Thomas E. Dunlop	01 Feb 1968
CDR Walter H. McCall	02 May 1969
CDR Robert W. McKay	31 Mar 1970
CDR Richard F. Coleman	26 Mar 1971
CDR John H. Fetterman, Jr.	29 Mar 1972
CDR Edward J. Rice	20 Mar 1973
CDR Ronald G. Horne	1974
CDR J. D. Rasmussen	28 Aug 1975
CDR W. J. Catlett III	30 Nov 1976
CDR Donald A. Gerrish	15 Feb 1978
CDR Lewis W. Dunton III	27 Feb 1979

**Commanding Officers—Continued**

	<i>Date Assumed Command</i>
CDR Daniel D. Hill	23 Jun 1980
CDR Hugh C. Bowles	03 Sep 1981
CDR Michael F. O'Brien	11 Jan 1983
CDR Douglas G. Knappe	13 Jun 1984
CDR Raymond A. Dudderar	07 Nov 1985
CDR Timothy J. Keating	22 May 1987
CDR Orren R. Crouch	23 Jan 1989
CDR John C. Stencil	14 Jun 1990

**Aircraft Assignment**

<i>Type of Aircraft</i>	<i>Date</i>	<i>Type First Received</i>
A-7B		09 Jun 1968
A-7E		1975*
F/A-18A		24 Oct 1986

\* It is believed VA-87 received its first A-7E in October 1975.

**Major Overseas Deployments**

<i>Date of Departure</i>	<i>Date of Return</i>	<i>Air Wing</i>	<i>Carrier</i>	<i>Type of Aircraft</i>	<i>Area of Operation</i>
01 Feb 1969	18 Sep 1969	CVW-16	CVA 14	A-7B	WestPac/Vietnam
29 Jan 1971	23 Jul 1971	CVW-6	CVA 42	A-7B	Med
15 Feb 1972	08 Dec 1972	CVW-6	CVA 42	A-7B	Med
14 Sep 1973	17 Mar 1974	CVW-6	CVA 42	A-7B	Med
03 Jan 1975	16 Jul 1975	CVW-6	CV 42	A-7B	Med
15 Apr 1976	25 Oct 1976	CVW-6	CV 66	A-7E	Med
10 Jun 1977	19 Jul 1977	CVW-6	CV 66	A-7E	SoLant
29 Sep 1977	25 Apr 1978	CVW-6	CV 66	A-7E	Med
28 Jun 1979	14 Dec 1979	CVW-6	CV 62	A-7E	Med
19 Nov 1980	10 Jun 1981	CVW-6	CV 62	A-7E	SoLant/IO/Med
07 Jun 1982	22 Dec 1982	CVW-6	CV 62	A-7E	Med
18 Oct 1983	11 Apr 1984	CVW-6	CV 62	A-7E	Carib/Med/ NorLant
16 Oct 1984	19 Feb 1985	CVW-6	CV 62	A-7E	Med/IO
25 Aug 1988	11 Oct 1988	CVW-8	CVN 71	F/A-18A	NorLant
30 Dec 1988	30 Jun 1989	CVW-8	CVN 71	F/A-18A	Med
28 Dec 1990	28 Jun 1991	CVW-8	CVN 71	F/A-18A	Med/Red Sea/Persian Gulf



*A squadron F/A-18C Hornet in flight, 1991.*



**Air Wing Assignments**

<i>Air Wing</i>	<i>Tail Code</i>	<i>Assignment Date</i>
COMFAIRJACKSON-VILLE		01 Feb 1968
CVW-16	AH	1969
COMFAIRJACKSON-VILLE		Sep 1969
CVW-6	AE	01 Aug 1970
COMLATWING-1		Jul 1985
CVW-8	AJ	01 Sep 1987

**Unit Awards Received**

<i>Unit Award</i>	<i>Inclusive Dates Covering Unit Award</i>	
MUC	18 Feb 1969	07 Sep 1969
	09 Mar 1972	01 Dec 1972
HSM	20 Jun 1976	27 Jul 1976
NEM	07 Dec 1980	11 May 1981
	20 Aug 1982	05 Sep 1982
	01 Oct 1982	06 Dec 1982
NUC	20 Oct 1983	03 Mar 1984
RVNGC	04 Mar 1969	08 Mar 1969
	10 Mar 1969	
	12 Mar 1969	19 Mar 1969
	29 Mar 1969	31 Mar 1969
	02 Apr 1969	03 Apr 1969
	06 Apr 1969	07 Apr 1969
	09 Apr 1969	15 Apr 1969
	10 May 1969	29 May 1969
	31 May 1969	03 Jun 1969
	28 Jun 1969	30 Jun 1969
VNSM	03 Mar 1969	20 Mar 1969
	29 Mar 1969	16 Apr 1969
	09 May 1969	04 Jun 1969
	25 Jun 1969	01 Aug 1969

**Unit Awards Received**

<i>Unit Award</i>	<i>Inclusive Dates Covering Unit Award</i>	
AFEM	20 Apr 1969	27 Apr 1969
	04 Aug 1969	
	16 Aug 1969	24 Aug 1969
	30 Aug 1969	
	24 Oct 1983	02 Nov 1983
	16 Nov 1983	22 Dec 1983
	28 Dec 1983	03 Jan 1984
	15 Jan 1984	03 Feb 1984
	09 Feb 1984	02 Mar 1984



*A squadron A-7E Corsair II with a low-visibility paint scheme, 1984.*

## VFA-94

### Lineage

Established as Fighter Squadron NINETY FOUR (VF-94) on 26 March 1952.

Redesignated Attack Squadron NINETY FOUR (VA-94) on 1 August 1958.

Redesignated Strike Fighter Squadron NINETY FOUR (VFA-94) on 28 June 1990. The second squadron to be assigned the VA-94 designation and the first to be assigned the VFA-94 designation.

### Squadron Insignia and Nickname

When the squadron deployed aboard Hornet (CVA 12) during its world cruise in 1954 it was using a cartoon cat insignia. There is no record of this insignia being officially approved for use by the squadron.



*This cartoon cat insignia was used by the squadron prior to 1955 but was never officially approved.*

The squadron's first official insignia was approved by CNO on 21 November 1955. Colors for the tiger paw insignia were: a blue background outlined in yellow; the tiger paw was yellow, orange and black with the under part of the paw white

with black marks, the claws were black outlined in yellow; the lightning bolts were yellow; and the bomb blast was white with an orange-red center; the scroll was blue with a black outline and lettering.

A new insignia was approved by CNO on 21 April 1959. Colors for this insignia were: a light blue background; dark blue stylized aircraft with an orange contrail; dark blue crescent; red atom symbol with dark blue electrons; and an orange scroll with dark blue lettering.

A modification to the insignia was approved by



*The tiger paw design was the first insignia approved for use by the squadron, 1955.*



*The squadron's second insignia used the atom symbol with electrons and a stylized aircraft, 1959.*



*A modification to the second insignia was approved in 1967. The atom symbol was replaced with a stylized bird design. In 1990, CNO approved another modification to this design, replacing the Attack Squadron 94 designation in the scroll to Strike Fighter Squadron 94.*

CNO on 16 May 1967. The atom symbol was replaced by a stylized bird design. The stylized bird was orange and the other colors from the previous design stayed the same.

On 14 September 1990 CNO approved a modification to the insignia which changed the designation in the scroll to Strike Fighter Squadron 94.

Nickname: Shrikes or Mighty Shrikes, 1959-present.

### Chronology of Significant Events

**May 1963:** Following the military losses of Laotian neutralists to the Pathet Lao in the Plaine de Jarres, Laos, *Ranger* (CVA 61) with VA-94 embarked, transited to the South China Sea to support possible operations in Laos.

**1 Dec 1964:** The squadron flew its first sorties in support of Yankee Team Operations, armed escort for photoreconnaissance missions over Laos.

**7 Feb 1965:** Following a Viet Cong attack against the American advisors compound at Pleiku, South Vietnam, the President ordered a reprisal strike against North Vietnam, named Flaming Dart I. The squadron's target, Vit Thu Lu barracks, was concealed by heavy weather and the mission was aborted due to the bad weather.

**11 Feb 1965:** The squadron participated in Flaming Dart II, retaliatory strikes against the Chanh Hoa military barracks near Dong Hoi, North Vietnam.

**Mar 1965:** The squadron participated in Rolling Thunder strikes against the Phu Qui ammunition depot in North Vietnam.

**9 May 1972:** The squadron participated in Operation Pocket Money, the mining of Haiphong harbor. Aircraft from VA-94, as well as the other attack squadrons deployed aboard *Coral Sea* (CVA 43), planned and executed the mining of the harbor.

**May-Jun 1972:** VA-94 participated in operation Linebacker I, heavy air strikes against targets in North Vietnam.

**29 Apr 1975:** Squadron aircraft provided air cover for Operation Frequent Wind, the evacuation of American citizens from Saigon.

**15 May 1975:** VA-94 aircraft, along with other elements from CVW-15 embarked in *Coral Sea*, launched air strikes against the Cambodian mainland after the capture of the SS *Mayaguez* by Cambodian gunboats



Two squadron A-7E Corsair IIs in flight, 1971.

on 12 May. Combat sorties were flown against targets at Ream Naval Facility, Kompong Som Naval Facility and a Cambodian patrol boat.

**27 Oct 1979:** Following the assassination of Park Chung Hee, President of the Republic of Korea, *Kitty Hawk* (CV 63), with VA-94 embarked, was ordered to operate off the coast of Korea.

**21 Nov 1979:** *Kitty Hawk*, along with VA-94 and the rest of CVW-15, departed Subic Bay, Philippines, enroute to the Arabian Sea in response to the 4 November Iranian seizure of the American Embassy in Tehran and the taking of over 60 American hostages.

**14 Jun 1982:** While the squadron was deployed to NAS Fallon for weapons training, its commanding officer, Commander M. A. Gary, was killed in a landing accident.

**Apr-Jul 1986:** In late April *Enterprise* (CVN 65), with VA-94 embarked, transited the Suez Canal from the Indian Ocean to the Mediterranean Sea to augment the carrier forces in the Med. Earlier in the month, American strikes were flown against Libyan military targets as a response to Libya's continuing support of terrorist activity.

**Feb-May 1988:** The squadron flew air support for Operation Earnest Will, escorting reflagged Kuwaiti oil tankers in the Persian Gulf.

**18 Apr 1988:** VA-94 participated in Operation Praying Mantis, retaliatory strikes against Iranian oil platforms, gunboats and other naval ships after *Sameul B. Roberts* (FFG 58) struck an Iranian mine in international waters on 14 April. Squadron aircraft delivered direct hits on the Iranian frigate *Saband*.

**Dec 1989:** The squadron participated in Operation Classic Resolve, providing support for the Philippine government during a coup attempt.



A squadron F4U-4 Corsair on the deck of Philippine Sea (CVA 47) during her deployment to Korea, 1952–1953.

### Home Port Assignments

Location	Assignment Date
NAS Alameda	26 Mar 1952
NAS Moffett Field	Jan 1955
NAS Alameda	20 Aug 1958
NAS Lemoore	08 Mar 1962



A squadron F9F-5 Panther on the deck of Hornet (CVA 12) during her world cruise in 1954.

### Commanding Officers

	Date Assumed Command
CDR Armind T. Holderman	09 Apr 1952
LCDR R. A. Singleton (acting)	Mar 1953
CDR Armind T. Holderman	01 Jul 1953
CDR William T. Harding	Sep 1953
CDR C. H. Gates	Jun 1955
CDR Robert M. Soule	1956
CDR Francis X. Brady	Sep 1956
CDR Richard D. Lazenby	28 Jul 1958
CDR D. G. Patterson	24 Jul 1959
CDR G. M. Hart	02 Sep 1960
CDR J. A. Endacott	20 Dec 1961
CDR Donald Loranger	Dec 1962
CDR Malcolm E. Vail	10 Dec 1963

**Commanding Officers—Continued**

	<i>Date Assumed Command</i>
CDR Paul A. Peck	05 Nov 1964
CDR Otto E. Krueger	23 Oct 1965
CDR J. H. Wynn III	28 Oct 1966
CDR Joseph B. Wilkinson, Jr.	09 Nov 1967
CDR John E. Wasson	08 Nov 1968
CDR Zygmunt J. Kowalskey, Jr.	26 Nov 1969
CDR Robert B. Browning	22 Oct 1970
CDR David L. Moss	29 Oct 1971
CDR W. A. Lacey	13 Oct 1972
CDR Ted W. Reynolds	26 Sep 1973
CDR Harvey A. Eikel	21 Jan 1975
CDR S. R. Briggs	15 Apr 1976

**Commanding Officers—Continued**

	<i>Date Assumed Command</i>
CDR John A. Moriarty	01 Jul 1977
CDR Paul E. Otto	20 Oct 1978
CDR Paul A. Cassiman	20 Jan 1980
CDR James I. Maslowski	23 Mar 1981
CDR M. A. Gary	04 Jun 1982
CDR J. J. Zerr	28 Jun 1982
CDR E. L. Tetrick	14 Feb 1983
CDR Terrence L. Hightower	Jun 1984
CDR Larry S. Doyle	17 Oct 1985
CDR Carl W. Chamberlain	27 Feb 1987
CDR John A. Roe	01 Sep 1988
CDR Lewis G. Mason	26 Apr 1990



*A squadron F9F-8B Cougar at NAS Moffett Field, California, June 1957 (Courtesy Robert Lawson Collection).*

**Aircraft Assignment**

<i>Type of Aircraft</i>	<i>Date Type First Received</i>
FG-1D	Apr 1952
F4U-4	Aug 1952
F9F-5	Sep 1953
FJ-3	Feb 1955
F9F-8	Nov 1955
F9F-8B	Apr 1956
FJ-3	Jun 1957
FJ-3M	01 Jul 1957

**Aircraft Assignment—Continued**

<i>Type of Aircraft</i>	<i>Date Type First Received</i>
FJ-3M	01 Jul 1957
FJ-4	25 Aug 1958
A4D-2	11 Jan 1959
A4D-2N/A-4C*	07 Sep 1960
A-4E	23 Oct 1967
A-7E	Jan 1971
F/A-18C	05 May 1990

\* The A4D-2N designation was changed to A-4C in 1962.

*A squadron FJ-3M Fury, circa 1958 (Courtesy Robert Lawson Collection).*



**Major Overseas Deployments**

<i>Date of Departure</i>	<i>Date of Return</i>	<i>Air Wing</i>	<i>Carrier</i>	<i>Type of Aircraft</i>	<i>Area of Operation</i>
15 Dec 1952	14 Aug 1953	CVG-9	CVA 47	F4U-4	WestPac/Korea
11 May 1954	12 Dec 1954	CVG-9	CVA 12	F9F-5	World Cruise
19 Mar 1956	13 Sep 1956	ATG-4	CVA 10	F9F-8B	WestPac
06 Jan 1958	30 Jun 1958	ATG-4	CVA 12	FJ-3M	WestPac
06 Feb 1960	30 Aug 1960	CVG-9	CVA 61	A4D-2	WestPac
11 Aug 1961	08 Mar 1962	CVG-9	CVA 61	A4D-2N	WestPac
09 Nov 1962	14 Jun 1963	CVG-9	CVA 61	A-4C	WestPac
05 Aug 1964	06 May 1965	CVW-9	CVA 61	A-4C	WestPac/Vietnam
26 Oct 1965	21 Jun 1966	CVW-9	CVAN 65	A-4C	WestPac/Vietnam
05 Jan 1967	22 Jul 1967	CVW-5	CVA 19	A-4C	WestPac/Vietnam
27 Jan 1968	10 Oct 1968	CVW-5	CVA 31	A-4E	WestPac/Vietnam
18 Mar 1969	29 Oct 1969	CVW-5	CVA 31	A-4E	WestPac/Vietnam
02 Apr 1970	12 Nov 1970	CVW-5	CVA 31	A-4E	WestPac/Vietnam
12 Nov 1971	17 Jul 1972	CVW-15	CVA 43	A-7E	WestPac/Vietnam
09 Mar 1973	08 Nov 1973	CVW-15	CVA 43	A-7E	WestPac
05 Dec 1974	02 Jul 1975	CVW-15	CVA 43	A-7E	WestPac
15 Feb 1977	05 Oct 1977	CVW-15	CV 43	A-7E	WestPac
30 May 1979	25 Feb 1980	CVW-15	CV 63	A-7E	WestPac/IO
01 Apr 1981	23 Nov 1981	CVW-15	CV 63	A-7E	WestPac/IO
01 Sep 1982	28 Apr 1983	CVW-11	CVN 65	A-7E	NorPac/ WestPac/IO
30 May 1984	20 Dec 1984	CVW-11	CVN 65	A-7E	WestPac/IO/ NorPac
12 Jan 1986	13 Aug 1986	CVW-11	CVN 65	A-7E	WestPac/IO/ Med/Solant
25 Oct 1987	24 Nov 1987	CVW-11	CVN 65	A-7E	NorPac
05 Jan 1988	03 Jul 1988	CVW-11	CVN 65	A-7E	WestPac/IO/ NorPac
17 Sep 1989	16 Mar 1990	CVW-11	CVN 65	A-7E	World Cruise



*A squadron A-4E Skyhawk flies over Bon Homme Richard (CVA 31) during her deployment to Vietnam in 1969.*

### Air Wing Assignments

<i>Air Wing</i>	<i>Tail Code</i>	<i>Assignment Date</i>
CVG-9	N	26 Mar 1952
ATG-4	Z/ND*	1955
CVG-9/CVW-9†	NG	01 Aug 1958
CVW-5	NF	01 Jul 1966
COMFAIRLEMOORE		Nov 1970
CVW-15	NL	02 Jan 1971
CVW-11	NH	18 Jan 1982

\* The tail code was changed from Z to ND in 1957. The effective date for this change was most likely the beginning of FY 58 (1 July 1957).

† CVG-9 was redesignated CVW-9 when Carrier Air Groups (CVG) were redesignated Carrier Air Wings (CVW) on 20 December 1963.



*A squadron A-7E Corsair II, in a low-visibility paint scheme, preparing to trap aboard Enterprise (CVN 65) in 1989.*

### Unit Awards Received

<i>Unit Award</i>	<i>Inclusive Dates Covering Unit Award</i>	
KPUC	31 Jan 1953	27 Jul 1953
KSM	25 Jan 1953	01 Aug 1953
NUC	31 Jan 1953	27 Jul 1953
	21 Feb 1968	13 Sep 1968
	15 Dec 1971	01 Jul 1972
NAVE	01 Jul 1973	30 Jun 1974
	01 Jul 1983	31 Dec 1984
	01 Jan 1989	31 Dec 1989
AFEM	24 Jun 1960	25 Jun 1960
	01 May 1963	05 May 1963
	18 Sep 1964	20 Sep 1964
	01 Oct 1964	09 Oct 1964
	28 Nov 1964	01 Jan 1965
	16 Jan 1965	17 Mar 1965
	04 Apr 1965	14 Apr 1965
	04 May 1968	07 May 1968
	29 Jun 1969	
	07 Jul 1969	13 Jul 1969
	24 Jul 1969	
	03 Sep 1969	
	13 Sep 1969	14 Sep 1969
	29 Apr 1975	30 Apr 1975
	15 May 1975	
15 Feb 1988	09 Mar 1988	
17 Jan 1990	31 Jan 1990	
HSM	29 Apr 1975	30 Apr 1975
	17 May 1981	
	02 Oct 1981	
MUC	23 Oct 1982	
	20 Jan 1967	14 Jul 1967
	18 Apr 1969	08 Oct 1969
	02 May 1970	20 Oct 1970
	22 Apr 1975	30 Apr 1975
	15 May 1975	
	13 Nov 1979	08 Feb 1980
01 Oct 1983	31 Mar 1985	
15 Feb 1988	09 Mar 1988	

### Unit Awards Received—Continued

<i>Unit Award</i>	<i>Inclusive Dates Covering Unit Award</i>	
NEM	25 Nov 1979	28 Jan 1980
	25 May 1981	30 Sep 1981
	30 Apr 1986	27 Jun 1986
RVNGC	02 Dec 1965	
	11 Dec 1965	
	21 Dec 1965	
	24 Dec 1965	
	26 Dec 1965	30 Dec 1965
	01 Jan 1966	02 Jan 1966
	04 Jan 1966	14 Jan 1966
	04 Feb 1966	
	19 Feb 1966	
	23 Feb 1966	
	27 Mar 1966	28 Mar 1966
	30 Mar 1966	31 Mar 1966
	02 Apr 1966	
	11 Apr 1966	
	29 Apr 1966	
20 Feb 1967		
23 Feb 1967		
16 Mar 1967		
24 Mar 1967	25 Mar 1967	
07 May 1967		
09 May 1967		
12 May 1967		
15 May 1967	21 May 1967	
29 May 1967	30 May 1967	
03 Jun 1967		
16 Jun 1967		
21 Feb 1968	25 Feb 1968	
27 Feb 1968	07 Mar 1968	
12 Mar 1968	18 Mar 1968	
22 Mar 1968	23 Mar 1968	
25 Mar 1968		
06 Apr 1968	11 Apr 1968	
13 Apr 1968	14 Apr 1968	
17 Apr 1968	20 Apr 1968	

**Unit Awards Received—Continued**

<i>Unit Award</i>	<i>Inclusive Dates Covering Unit Award</i>	
	13 May 1968	14 May 1968
	26 May 1968	27 May 1968
	04 Jul 1968	
	02 Aug 1968	18 Aug 1968
	27 Aug 1968	14 Sep 1968
	18 Apr 1969	17 May 1969
	01 Jun 1969	
	04 Jun 1969	09 Jun 1969
	11 Jun 1969	24 Jun 1969
	26 Jun 1969	
VNSM	02 Dec 1965	14 Jan 1966
	04 Feb 1966	23 Feb 1966
	16 Mar 1966	12 Apr 1966
	22 Apr 1966	14 May 1966
	23 May 1966	06 Jun 1966
	04 Feb 1967	26 Feb 1967
	15 Mar 1967	12 Apr 1967
	27 Apr 1967	05 Jun 1967
	11 Jun 1967	28 Jun 1967
	20 Feb 1968	25 Mar 1968
	06 Apr 1968	20 Apr 1968

**Unit Awards Received—Continued**

<i>Unit Award</i>	<i>Inclusive Dates Covering Unit Award</i>	
	09 May 1968	30 May 1968
	04 Jun 1968	05 Jun 1968
	13 Jun 1968	07 Jul 1968
	21 Jul 1968	18 Aug 1968
	27 Aug 1968	14 Sep 1968
	17 Apr 1969	18 May 1969
	03 Jun 1969	26 Jun 1969
	30 Jul 1969	31 Aug 1969
	23 Sep 1969	08 Oct 1969
	02 May 1970	26 May 1970
	01 Jun 1970	14 Jun 1970
	01 Jul 1970	29 Jul 1970
	17 Aug 1970	03 Sep 1970
	11 Sep 1970	12 Sep 1970
	26 Sep 1970	21 Oct 1970
	14 Dec 1971	
	31 Dec 1971	17 Jan 1972
	26 Jan 1972	17 Feb 1972
	01 Apr 1972	11 May 1972
	01 Jun 1972	11 Jun 1972
	21 Jun 1972	02 Jul 1972



*A squadron F/A-18C Hornet flies over the burning oil fields of Kuwait, 1991.*

## VFA-97

### Lineage

Established as Attack Squadron NINETY SEVEN (VA-97) on 1 June 1967.

Redesignated Strike Fighter Squadron NINETY SEVEN (VFA-97) on 24 January 1991. The first squadron to be assigned the VA-97 and VFA-97 designation.

### Squadron Insignia and Nickname

The squadron's insignia was approved by the CNO on 6 March 1968. Colors for the hawk and shield insignia are as follows: background light blue outlined in black; gold scroll outlined in black with black lettering; black hawk with gold markings, a gold beak, red tongue and eye; dark blue shield with a gold trident, both outlined in black; gray knight's helmet with a blue and gold crest and black markings.



The squadron's hawk and trident insignia.

Nickname: Warhawks, 1968-present.

### Chronology of Significant Events

28 Jun 1968: The squadron conducted its first combat missions.

4 Feb–7 Mar 1971: The squadron embarked in *Enterprise* (CVAN 65) for the ship's transit around South America to her new home port on the west coast.

Dec 1971: Following the outbreak of war between India and Pakistan over East Pakistan (Bangladesh), *Enterprise* (CVAN 65) was ordered to leave Yankee Station for operations in the Indian Ocean. The carrier, with Air Wing 14 embarked, operated in the Bay of Bengal until the cessation of hostilities in the latter part of December.

Oct 1972: Squadron aircraft participated in Linebacker I operations, heavy air strikes against targets in North Vietnam to interdict the flow of supplies into South Vietnam.

Dec 1972: The squadron participated in Linebacker II operations, an intensified version of Linebacker I.

Feb 1975: *Enterprise*, with CVW-14, provided disaster support for the island country of Mauritius following a tropical storm.

Apr 1975: The squadron participated in Operation Frequent Wind and provided air support for the evacuation of personnel from Saigon as it fell to the communists.

Feb 1977: During the crisis in Uganda and threats against Americans in that country, *Enterprise* operated off the coast of Kenya ready to evacuate Americans.

Dec 1979: *Coral Sea* (CV 43) operated off the coast of South Korea following the assassination of South Korea's President Park Chung-Hee in late October.

Apr 1980: *Coral Sea* was part of the task force involved in supporting the Iranian hostage rescue attempt.

May 1980: Following civil unrest in South Korea, *Coral Sea* operated off the coast of that country.

Aug 1983: Due to the unsettled conditions in Central America, *Coral Sea* operated off the coast of Nicaragua and also participated in surveillance for illegal drug traffic.

Aug 1986: The squadron participated in carrier tactical flight operations in the Bering Sea.

Jul 1988: During the Olympics in Seoul, Korea, *Carl Vinson* (CVN 70), with VA-97 embarked, operated off the coast of Korea.



A formation of squadron A-7E Corsair IIs, 1975.



**Home Port Assignments**

<i>Location</i>	<i>Assignment Date</i>
NAS Lemoore	01 Jun 1967

**Commanding Officers**

	<i>Date Assumed Command</i>
CDR Richard P. Vaillancourt	28 Jul 1967
CDR Leroy M. Kraft	27 Feb 1969
CDR James E. Doolittle	19 Dec 1969
CDR Robert B. Arnold	16 Dec 1970
CDR Hugh F. Lynch	27 Dec 1971
CDR Robert C. Coffey	15 Dec 1972
CDR Bert D. Terry	29 Mar 1974
CDR Robert P. Nicolls	26 Jun 1975
CDR John F. Murray	17 Sep 1976
CDR Rex R. Arnett, Jr.	22 Nov 1977
CDR John M. McGrath	11 Jan 1979

**Commanding Officers—Continued**

	<i>Date Assumed Command</i>
CDR David L. Carroll	29 Mar 1980
CDR Michael L. Bowman	06 Jun 1981
CDR Thomas L. McClelland	21 Sep 1982
CDR Norman L. Westerbuhr	03 Feb 1984
CDR Joseph W. Parker, Jr.	20 Sep 1985
CDR T. Barry McFarland	27 Mar 1987
CDR Michael F. Winkler	31 Jul 1988
CDR James T. Noland, Jr.	11 Jan 1990

**Aircraft Assignment**

<i>Type of Aircraft</i>	<i>Date Type First Received</i>
A-7A	Oct 1967
A-7E	Jul 1970
F/A-18A	22 Feb 1991



*A squadron A-7E Corsair II in flight with its low-visibility paint scheme, 1984.*

**Major Overseas Deployments**

<i>Date of Departure</i>	<i>Date of Return</i>	<i>Air Wing</i>	<i>Carrier</i>	<i>Type of Aircraft</i>	<i>Area of Operation</i>
29 May 1968	31 Jan 1969	CVW-14	CVA 64	A-7A	WestPac/Vietnam
11 Aug 1969	08 May 1970	CVW-14	CVA 64	A-7A	WestPac/Vietnam
11 Jun 1971	12 Feb 1972	CVW-14	CVAN 65	A-7E	WestPac/ Vietnam/IO
12 Sep 1972	12 Jun 1973	CVW-14	CVAN 65	A-7E	WestPac/Vietnam
17 Sep 1974	20 May 1975	CVW-14	CVAN 65	A-7E	WestPac/IO
30 Jul 1976	28 Mar 1977	CVW-14	CVN 65	A-7E	WestPac/IO
04 Apr 1978	30 Oct 1978	CVW-14	CVN 65	A-7E	WestPac/IO
13 Nov 1979	11 Jun 1980	CVW-14	CV 43	A-7E	WestPac/IO
20 Aug 1981	23 Mar 1982	CVW-14	CV 43	A-7E	WestPac/IO
21 Mar 1983	12 Sep 1983	CVW-14	CV 43	A-7E	World Cruise
13 Oct 1984	24 May 1985	CVW-15	CVN 70	A-7E	NorPac/ WestPac/IO
12 Aug 1986	05 Feb 1987	CVW-15	CVN 70	A-7E	NorPac/ WestPac/IO
15 Jun 1988	14 Dec 1988	CVW-15	CVN 70	A-7E	NorPac/ WestPac/IO
05 Sep 1989	09 Nov 1989	CVW-15	CVN 70	A-7E	NorPac/WestPac
01 Feb 1990	31 Jul 1990	CVW-15	CVN 70	A-7E	WestPac/IO

**Air Wing Assignments**

<i>Air Wing</i>	<i>Tail Code</i>	<i>Assignment Date</i>
CVW-14	NK	15 Dec 1967*
CVW-15	NL	01 Nov 1983

\* Before being assigned to CVW-14 the squadron was under the operational and administrative control of VA-122 during its training in the A-7A Corsair II.

**Unit Awards Received**

<i>Unit Award</i>	<i>Inclusive Dates Covering Unit Award</i>	
NAVE	01 Jul 1968	31 Dec 1969
	01 Jul 1974	31 Dec 1975
	01 Jan 1988	31 Dec 1988
MUC	07 Sep 1969	30 Apr 1970
	02 Jul 1971	03 Feb 1972
	22 Apr 1975	30 Apr 1975
	07 Mar 1978	01 May 1980
	10 Nov 1984	07 May 1985
NUC	16 Jan 1987	02 Feb 1987
	03 Oct 1972	22 Feb 1973
AFEM	16 Oct 1969	24 Oct 1969
	16 Mar 1970	23 Mar 1970
	29 Apr 1975	30 Apr 1975
HSM	29 Apr 1975	30 Apr 1975
	27 Jun 1968	22 Jul 1968
VNSM	02 Aug 1968	28 Aug 1968
	11 Sep 1968	09 Oct 1968
	28 Nov 1968	29 Nov 1968
	09 Dec 1968	21 Dec 1968
	01 Jan 1969	07 Jan 1969
	11 Sep 1969	03 Oct 1969

**Unit Awards Received—Continued**

<i>Unit Award</i>	<i>Inclusive Dates Covering Unit Award</i>	
	01 Nov 1969	23 Nov 1969
	07 Dec 1969	22 Dec 1969
	05 Jan 1970	30 Jan 1970
	12 Feb 1970	01 Mar 1970
	26 Mar 1970	17 Apr 1970
	14 Jul 1971	31 Jul 1971
	15 Aug 1971	04 Sep 1971
	12 Sep 1971	
	25 Sep 1971	26 Sep 1971
	02 Oct 1972	23 Oct 1972
	01 Nov 1972	11 Dec 1972
	18 Dec 1972	13 Jan 1973
	24 Jan 1973	23 Feb 1973
	01 Mar 1973	02 Mar 1973
	11 Mar 1973	28 Mar 1973



*A squadron F/A-18A Hornet at NAS Lemoore, California, 1991.*

## VFA-105

### Lineage

Established as Attack Squadron ONE HUNDRED FIVE (VA-105) on 1 November 1967.

Redesignated Strike Fighter Squadron ONE HUNDRED FIVE (VFA-105) on 17 December 1990. The second squadron to be assigned the designation VA-105 and the first to be designated VFA-105.



The squadron's insignia as it was first approved in 1968.



In 1984, a modification was approved for the squadron's insignia that added an upper scroll with the nickname *Gunslingers*. When the squadron was redesignated VFA, the designation in the lower scroll changed from *ATKRON 105* to *STRKFITRON 105*.

### Squadron Insignia and Nickname

The squadron's insignia was approved by the CNO on 20 September 1968. Colors for the knight and holster insignia are as follows: a white background with a kelly green border; silver 45 caliber revolver with a black handle; black holster and gold knight; black ammunition belt with silver trim and gold bullets; kelly green scroll with white lettering.

On 31 December 1984 the CNO approved a modification to the squadron insignia. The modification included adding an upper scroll with the nickname *Gunslingers* and changes to the colors. The background color and lettering in the scrolls were changed to silver and the insignia was outlined in black.

Nickname: *Gunslingers*, 1968-present.

### Chronology of Significant Events

**4 Mar 1968:** The squadron completed its training under VA-174 on the A-7A and became an operational unit of the Atlantic Fleet.

**May and Jun 1969:** Following the shootdown of a Navy EC-121 by the North Koreans in April, *Kitty Hawk* (CVA 63) was part of a continuing American presence being maintained off the coast of Korea.

**Sep and Oct 1970:** Following the hijacking of several airliners by Palestinians, the outbreak of serious fight-

ing in Jordan and the invasion of Jordan by Syria, *Saratoga* (CVA 60) with VA-105 embarked, operated in the eastern Mediterranean, prepared to support an evacuation of Americans from Jordan and to show support for the Jordanian government.

**Jun-Oct 1971:** As part of CVW-3, embarked in *Saratoga*, the squadron participated in the CV Concept Evaluation while deployed to the North Atlantic and Mediterranean Sea. The concept added antisubmarine warfare to the missions of the attack carriers. ASW aircraft were added to the carrier air wings and the carriers were redesignated from CVA to CV.

**Jun-Oct 1972:** The squadron participated in Linebacker I operations, heavy air strikes against targets in North Vietnam to interdict the flow of supplies into South Vietnam.

**18-29 Dec 1972:** Squadron aircraft participated in Linebacker II operations against North Vietnam, an intensified version of Linebacker I.

**Jan 1975:** Following violent demonstrations in Cyprus, *Saratoga* operated off the coast of that island country, prepared to provide support for the possible evacuation of Americans.

**Apr 1976:** The squadron operated off the coast of Lebanon and participated in Operation Fluid Drive, preparations to support a possible evacuation of Americans from that country.

**Jun 1982:** Following the invasion of Lebanon by Israel on 6 June, *John F. Kennedy* (CV 67) operated off the coast of Lebanon, available to support an evacuation of Americans from that country.

**Jul-Dec 1984:** The squadron returned from a six-month deployment to MCAS Iwakuni in the western Pacific. It was assigned to MAG-12, 1st MAW. This was the first time a Navy squadron participated in the Marine Corps Unit Deployment Program and the first Navy squadron since World War II to come under the command of a Marine Corps officer. While deployed with the Marines the squadron's major mission was close air support.



A squadron A-7E Corsair II in 1978.

**Home Port Assignments**

<i>Location</i>	<i>Assignment Date</i>
NAS Cecil Field	01 Nov 1967

**Commanding Officers**

	<i>Date Assumed Command</i>
CDR R. C. Bos	01 Nov 1967
CDR R. K. Halverson	21 Jan 1969
CDR C. R. Bowling	30 Dec 1969
CDR J. C. Perkins	05 Oct 1970
CDR H. B. Chase	16 Jul 1971
CDR W. R. Zipperer	07 May 1972
CDR P. N. Puerling	23 May 1973
CDR R. F. Moreau	20 Jul 1974
CDR J. E. Carpenter	17 Nov 1975
CDR F. H. Saunders	07 Jan 1977
CDR B. M. Bennitt	27 Apr 1978
CDR R. M. Nutwell	03 Jul 1979

**Commanding Officers—Continued**

	<i>Date Assumed Command</i>
CDR R. G. Pearson	06 Nov 1980
CDR D. V. Raebel	17 Feb 1981
CDR R. G. Brodsky	10 May 1982
CDR D. A. Weiss	17 Nov 1983
CDR G. G. Johnson	16 May 1985
CDR L. E. Osborn	06 Oct 1986
CDR K. T. Lewis	25 Mar 1988
CDR K. A. Richardson	27 Jul 1989
CDR Gene A. Smith	28 Mar 1991

**Aircraft Assignment**

<i>Type of Aircraft</i>	<i>Date Type First Received</i>
A-7A	04 Mar 1968
A-7E	07 May 1973
F/A-18A	27 Dec 1990
F/A-18C	11 Mar 1991

**Major Overseas Deployments**

<i>Date of Departure</i>	<i>Date of Return</i>	<i>Air Wing</i>	<i>Carrier</i>	<i>Type of Aircraft</i>	<i>Area of Operation</i>
30 Dec 1968	04 Sep 1969	CVW-11	CVA 63	A-7A	WestPac/Vietnam
17 Jun 1970	09 Nov 1970	CVW-3	CVA 60	A-7A	Med
07 Jun 1971	28 Oct 1971	CVW-3	CVA 60	A-7A	NorLant/Med
11 Apr 1972	13 Feb 1973	CVW-3	CV 60	A-7A	WestPac/Vietnam
27 Sep 1974	19 Mar 1975	CVW-3	CV 60	A-7E	Med
06 Jan 1976	28 Jul 1976	CVW-3	CV 60	A-7E	Med
11 Jul 1977	23 Dec 1977	CVW-3	CV 60	A-7E	Med
03 Oct 1978	05 Apr 1979	CVW-3	CV 60	A-7E	Med
10 Mar 1980	27 Aug 1980	CVW-3	CV 60	A-7E	Med
04 Jan 1982	14 Jul 1982	CVW-3	CV 67	A-7E	Med/IO
01 Mar 1983	29 Oct 1983	CVW-15	CVN 70	A-7E	World Cruise
02 Jun 1984	17 Dec 1984	MAG-12	*	A-7E	WestPac
02 Jun 1986	10 Nov 1986	CVW-6	CV 59	A-7E	Med
28 Aug 1987	09 Oct 1987	CVW-6	CV 59	A-7E	NorLant
25 Apr 1988	07 Oct 1988	CVW-6	CV 59	A-7E	Med/IO/NorLant
04 Nov 1989	12 Apr 1990	CVW-6	CV 59	A-7E	Med

\* The squadron deployed to MCAS Iwakuni, Japan, as part of Marine Aircraft Group 12. While deployed to WestPac the squadron also operated from NAF Kadena, Okinawa; NAS Cubi Point, Philippines and stations in Korea.



*A squadron A-7E Corsair II in flight with low-visibility paint scheme, 1984.*

**Air Wing Assignments**

<i>Air Wing</i>	<i>Tail Code</i>	<i>Assignment Date</i>
VA-174*		01 Nov 1967
COMFAIRJACKSON-VILLE		01 Mar 1968
CVW-11	NH	1968†
COMFAIRJACKSON-VILLE		Sep
CVW-3	AC	1970‡
CVW-15	NL	01 Oct 1982
COMLATWING ONE		Oct 1983
MAG-12, 1st MAW§	AC	08 Jun 1984
COMLATWING ONE		Dec 1984
CVW-6	AE	01 Apr 1985
COMLATWING ONE		01 Oct 1990
CVW-3	AC	01 Sep 1991

\* The squadron was assigned to VA-174 during training in the new A-7A Corsair II.

† The squadron was assigned to CVW-11 sometime after June 1968 and prior to its deployment in December 1968. Squadron and air wing records do not indicate the day or month.

‡ The squadron was assigned to CVW-3 sometime in the early part of 1970.

§ VA-105 was assigned to MAG-12, 1st MAW during its shorebased deployment to MCAS Iwakuni, Japan. While deployed with MAG-12 the squadron used the tail code AC on its aircraft.

**Unit Awards Received**

<i>Unit Award</i>	<i>Inclusive Dates Covering Unit Award</i>
NAVE	01 Jul 1968 01 Jul 1974 01 Oct 1976 01 Jan 1984
MUC	17 Sep 1970 01 Oct 1979
AFEM 1969	15 May 1969 25 May 1969 05 Jun 1969 07 Jun 1969 25 Jul 1969
NUC	15 Jan 1969 18 May 1972 01 Mar 1984
VNSM	27 Jan 1969 12 Mar 1969 17 Apr 1969 28 Jun 1969 27 Jul 1969 06 May 1972 17 May 1972 30 Jun 1972 27 Jul 1972 02 Sep 1972 29 Sep 1972 25 Oct 1972 03 Nov 1972 18 Dec 1972
	31 Dec 1969 30 Jun 1975 30 Sep 1977 31 Dec 1984 18 Oct 1970 15 Nov 1980 27 May 1969 15 Jun 1969 27 Aug 1969 08 Jan 1973 14 Dec 1984 01 Mar 1969 05 Apr 1969 11 May 1969 15 Jul 1969 17 Aug 1969 07 May 1972 22 Jun 1972 16 Jul 1972 23 Aug 1972 19 Sep 1972 21 Oct 1972 26 Oct 1972 08 Dec 1972 31 Dec 1972



*A squadron F/A-18C Hornet at NAS Fallon, Nevada, March 1992 (Courtesy Robert Lawson Collection).*

## VFA-106

### Lineage

Established as Strike Fighter Squadron ONE HUNDRED SIX (VFA-106) on 27 April 1984. The first squadron to be assigned the VFA-106 designation.

### Squadron Insignia and Nickname

The squadron's insignia was approved by CNO on 26 May 1982. The insignia approved for VFA-106 had been used by VA-106 prior to its disestablishment on 7 November 1969. Colors for the VFA-106 insignia are: a gold background outlined in red; a blue shield with a white arrow and Roman helmet, the upper part of the helmet is red; a gold stylized wing is on the upper right hand corner of the shield; white aircraft with blue markings; and blue scrolls with white lettering.



The *Gladiators* insignia used by the squadron.

Nickname: *Gladiators*, 1984-present.

### Chronology of Significant Events

**27 Apr 1984:** The squadron's mission is the training of F/A-18 replacement pilots and maintenance personnel for east coast F/A-18 fleet squadrons.

**7 Oct 1985:** The first Replacement Pilot Class arrives at VFA-106 to begin training on the F/A-18 Hornet.

### Home Port Assignments

Location	Assignment Date
NAS Cecil Field	27 Apr 1984

### Commanding Officers

	Date Assumed Command
CDR D. J. L'Herault	27 Apr 1984
CDR J. W. Peterson	13 Dec 1985
CDR L. G. Kappel	13 Feb 1987
CDR W. O. King, Jr.	03 Jun 1988
CDR W. N. Deaver, Jr.	12 Jun 1989
CDR J. Barry Waddell	19 Mar 1991

### Aircraft Assignment

Type of Aircraft	Date Type First Received
F/A-18A	09 Feb 1985
TF/A-18A	22 Mar 1985
F/A-18B	May 1986
F/A-18C	Oct 1987
F/A-18D	Dec 1987



A squadron F/A-18A Hornet in flight, May 1987 (Courtesy Robert Lawson Collection).

**Air Wing Assignments**

<i>Air Wing</i>	<i>Tail Code</i>	<i>Assignment Date</i>
COMLATWING ONE	AD	27 Apr 1984

**Unit Awards Received**

<i>Unit Award</i>	<i>Inclusive Dates Covering Unit Award</i>	
NUC	01 May 1985	30 Apr 1986
MUC	01 May 1986	31 Oct 1987
	01 Nov 1987	31 Dec 1989



*A squadron TF/A-18A Hornet at NAS Fallon, Nevada, March 1986 (Courtesy Robert Lawson Collection).*

## VFA-113

### Lineage

Established as Fighter Squadron ONE HUNDRED THIRTEEN (VF-113) on 15 July 1948.

Redesignated Attack Squadron ONE HUNDRED THIRTEEN (VA-113) in March 1956.

Redesignated Strike Fighter Squadron ONE HUNDRED THIRTEEN (VFA-113) on 25 March 1983. The first squadron to be assigned the VA-113 and VFA-113 designation.



*This beehive and hornet insignia was adopted by the squadron in 1949.*



*When the squadron was redesignated VFA, the insignia was modified by adding a scroll with the squadron designation; it was approved by CNO in 1983.*

### Squadron Insignia and Nickname

The squadron's insignia was approved by CNO on 15 April 1949. Colors for the insignia are: red beehive with white markings and outlined in yellow, with yellow lettering; black and yellow bumble bee with red legs and white wings with black markings.

CNO approved a modification to the insignia on 4 February 1985. The beehive insignia was placed inside a circle with a blue background outlined in yellow; the scroll is red, outlined in black and yellow, with yellow lettering; the other colors of the insignia remained the same.

Nickname: Stingers, 1949 to present.

### Chronology of Significant Events

**5 Aug 1950:** The squadron flew its first combat mission, striking land and sea targets southeast of Kunsan, Korea, and Mokpo harbor.

**12-14 Sep 1950:** Squadron aircraft flew combat sorties in and around Inchon, Korea, in preparation for the landings at Wolmi Island.

**15 Sep 1950:** The squadron participated in offensive sorties during the landings at Inchon, striking targets on the roads between Inchon and Seoul.

**2 & 5 Nov 1950:** Squadron aircraft participated in Operation Pinwheel, the docking and departing of the

carrier from the pier using aircraft engine power to move the ship.

**9-10 & 12 Nov 1950:** During strikes by the squadron's F4U-4Bs on bridges crossing the Yalu River between Sinuiju and Antung, they were attacked by MiG-15s. No damage was inflicted on the squadron's aircraft and no apparent damage was done to the MiG-15s.

**22-23 Dec 1950:** Two squadron aircraft flew spotting missions for *Saint Paul* (CA 73) on 22 December and for *Missouri* (BB 63) on 23 December during shore bombardment against villages and troop concentrations near the front line.

**23 Jun 1952:** Squadron aircraft, along with planes from 3 other air groups and the 5th Air Force, participated in the first coordinated strikes against North Korean hydroelectric power plants. This was the first time that enemy power plants had been so heavily targeted. It also marked the first time that four carriers were on line off the coast of Korea since the fall of 1950.

**8-13 Feb 1955:** Squadron aircraft were on station and available for air support during the evacuation of personnel from the Tachen Islands due to the bombardment of the islands by the People's Republic of China.

**Aug-Sep 1958:** The squadron was part of a task force that provided support to the Republic of China during the shelling of the Quemoy Island group by the Chinese Communists.

**11 Aug-1 Nov 1961:** The squadron was embarked in *Kitty Hawk* (CVA 63) for her transit, via Cape Horn, from Norfolk to her new home port at San Diego.

**Jun 1964:** Squadron aircraft participated in Yankee Team operations, including inflight refueling for RF-8A and RF-101 aircraft and search and rescue missions over South Vietnam and Laos.

**Nov 1964-Oct 1965:** The squadron provided a detachment of personnel and aircraft for use as fighter



*A squadron F4U-4 Corsair catching the wire aboard Philippine Sea (CV 47) during their 1951-1952 combat deployment to Korea.*



protection for the Antisubmarine Carrier Air Group embarked in *Bennington* (CVS 20).

**Dec 1965:** During the squadron's first line-period on Yankee Station, it participated in three major strikes against important North Vietnamese targets, including the Hai Phong Bridge, Uong Bi Thermal Power Plant and the Hai Duong Bridge.

**Jan–Feb 1968:** While embarked in *Enterprise* (CVAN 65) and enroute to Yankee Station, the carrier was ordered to the Sea of Japan for operations following the seizure of the *Pueblo* (AGER 2) by the North Koreans.

**Dec 1972:** The squadron participated in Linebacker II Operations, heavy air strikes against targets primarily around Hanoi and Haiphong.

**Jul 1976:** Following the Israeli raid on Entebbe and the threatened military operations against Kenya by Uganda, the *Ranger* (CV 61), with VA-113 embarked, was ordered to transit from the South China Sea to the western Indian Ocean and operate off the coast of Kenya.

**15 Oct 1980–22 Mar 1981:** Under the Swing Wing Concept to reduce the deck multiple on *Ranger*, VA-113 was off loaded at NAS Cubi Point and operated as a CVW-2 Detachment from the air station. While temporarily shore based the squadron participated in numerous joint and interservice exercises.

**Mar–Oct 1983:** The squadron underwent transition training with VFA-125, becoming the first Navy fleet operational squadron assigned the F/A-18 Hornet.

**Feb–Aug 1985:** VFA-113, along with VFA-25, made the first deployment with the new F/A-18 Hornet. The squadrons deployed aboard *Constellation* (CV 64) and operated in the western Pacific and Indian Ocean.

**Jul 1987:** Squadron aircraft, along with other units of CVW-14, conducted surveillance in the strategic Strait of Hormuz and provided air cover for the first five Earnest Will operations, the escort of reflagged Kuwaiti oil tankers through the Gulf of Oman and Persian Gulf.

**2 Aug 1990:** *Independence* (CV 62), with VFA-113 embarked, was ordered to the Gulf of Oman following the Iraqi invasion of Kuwait.

**Aug 1990:** The squadron's F/A-18s flew mixed combat air patrol missions with F-14s in the Persian Gulf up to 28 degrees north latitude in support of Operation Desert Shield, the build up of American and Allied forces to counter a threatened invasion of Saudi Arabia by Iraq and as part of an economic blockade of Iraq to force its withdrawal from Kuwait.

**3–4 Oct 1990:** VFA-113 conducted flight operations from *Independence* while she operated in the Persian Gulf. This was the first time a carrier had operated in the Persian Gulf since 1974.



*Squadron F9F-5 Panthers over Kearsarge (CVA 33) during their 1953–1954 deployment to Korea and WestPac.*

### Home Port Assignments

<i>Location</i>	<i>Assignment Date</i>
NAS San Diego	15 Jul 1948
NAS Miramar	15 Sep 1952
NAS Lemoore	12 Dec 1961

### Commanding Officers

	<i>Date Assumed Command</i>
LCDR Robert S. Merritt	15 Jul 1948
LCDR Roy M. Voris	09 Jun 1949
LCDR John T. O'Neill	20 Jan 1950
CDR Harold P. Ady, Jr.	30 Jun 1951
LCDR John R. Strane	24 Oct 1951
LCDR J. H. Tripp	29 Sep 1952
CDR Charles C. Sanders	Aug 1954
CDR Harold W. Davis	Apr 1955
CDR Richard L. Cormier	Dec 1956
CDR H. S. Matthews, Jr.	26 Nov 1958
CDR Robert E. Gallatin	16 Oct 1959
CDR L. A. Tomkins	17 Feb 1961
CDR G. A. White, Jr.	30 Mar 1962
CDR H. A. Borgerding	01 Mar 1963
CDR G. G. Zimmerman	21 Feb 1964
CDR Henry M. Dibble	02 Apr 1965
CDR J. Abbott (acting)	11 Apr 1966
CDR J. A. Burnett (acting)	04 May 1966
CDR R. E. Bennett	30 May 1966
CDR R. J. Thomas	16 Jul 1967
CDR E. J. Jacobs	23 Jul 1968
CDR J. E. Newton	03 Sep 1969
CDR J. Brent Streit	17 Jul 1970
CDR Weston H. Byng	26 Mar 1971
CDR Richard L. Grant	28 Apr 1972

**Commanding Officers—Continued**

**Aircraft Assignment**

	<i>Date Assumed Command</i>	<i>Type of Aircraft</i>	<i>Date Type First Received</i>
CDR D. Bruce Cargill	16 Apr 1973	F8F-1	15 Jul 1948
CDR Judson H. Springer	10 Dec 1973	F8F-2	28 Mar 1949
CDR M. D. Munsinger	28 Mar 1975	F4U-4B	09 Mar 1950
CDR H. D. Lesesne	17 May 1976	F9F-5	Oct 1952
CDR Michael J. Webber	26 Aug 1977	F9F-2	Feb 1954
CDR John P. Park	22 Nov 1978	F9F-8	May 1955
CDR T. D. Hill, Jr.	21 Feb 1980	F9F-8B	Apr 1956
CDR W. C. Trafton	10 Jun 1981	A4D-1	29 Apr 1957
CDR William W. Pickavance, Jr.	01 Aug 1982	A4D-2	08 Sep 1958
CDR C. A. Langbehn	29 Feb 1984	A4D-2N/A-4C*	29 Mar 1961
CDR Robert G. Sprigg	05 Sep 1985	A-4F	Oct 1967
CDR David V. Park	24 Jan 1987	A-7B	10 Dec 1968
CDR John V. Chenevey	28 Feb 1988	A-7E	Apr 1970
CDR Gary L. Koger	07 Jul 1989	F/A-18A	24 Aug 1983
CDR Danny L. Clarkson	24 Jan 1991	F/A-18C	09 Jun 1989

\* The A4D-2N designation was changed to A-4C in 1962.



*A squadron A4D-1 (A-4) Skyhawk on Hancock's (CVA 19) flight deck, November 1957.*

**Major Overseas Deployments**

<i>Date of Departure</i>	<i>Date of Return</i>	<i>Air Wing</i>	<i>Carrier</i>	<i>Type of Aircraft</i>	<i>Area of Operation</i>
05 Jul 1950	07 Apr 1951	CVG-11	CV 47/45*	F4U-4B	WestPac/Korea
31 Dec 1951	08 Aug 1952	CVG-11	CV 47	F4U-4	WestPac/Korea
01 Jul 1953	18 Jan 1954	CVG-11	CVA 33	F9F-5	WestPac/Korea
07 Oct 1954	12 May 1955	CVG-11	CVA 33	F9F-2	WestPac
16 Jul 1956	26 Jan 1957	CVG-11	CVA 9	F9F-8B	WestPac
08 Mar 1958	21 Nov 1958	CVG-11	CVA 38	A4D-1	WestPac
09 Mar 1959	03 Oct 1959	CVG-11	CVA 38	A4D-2	WestPac
16 Jul 1960	18 Mar 1961	CVG-11	CVA 19	A4D-2	WestPac
13 Sep 1962	02 Apr 1963	CVG-11	CVA 63	A4D-2N	WestPac
17 Oct 1963	20 Jul 1964	CVW-11	CVA 63	A-4C	WestPac
19 Oct 1965	13 Jun 1966	CVW-11	CVA 63	A-4C	WestPac/Vietnam
19 Nov 1966	06 Jul 1967	CVW-9	CVAN 65	A-4C	WestPac/Vietnam
03 Jan 1968	18 Jul 1968	CVW-9	CVAN 65	A-4F	WestPac/Vietnam
09 Jul 1969	22 Jan 1970	CVW-3	CVA 60	A-7B	Med
27 Oct 1970	17 Jun 1971	CVW-2	CVA 61	A-7E	WestPac/Vietnam
16 Nov 1972	23 Jun 1973	CVW-2	CVA 61	A-7E	WestPac/Vietnam
07 May 1974	18 Oct 1974	CVW-2	CVA 61	A-7E	WestPac
30 Jan 1976	07 Sep 1976	CVW-2	CV 61	A-7E	WestPac/IO
21 Feb 1979	22 Sep 1979	CVW-2	CV 61	A-7E	WestPac
10 Sep 1980	05 May 1981	CVW-2	CV 61	A-7E	WestPac/IO
07 Apr 1982	19 Oct 1982	CVW-2	CV 61	A-7E	WestPac/IO
21 Feb 1985	24 Aug 1985	CVW-14	CV 64	F/A-18A	WestPac/IO
04 Sep 1986	20 Oct 1986	CVW-14	CV 64	F/A-18A	NorPac
11 Apr 1987	13 Oct 1987	CVW-14	CV 64	F/A-18A	WestPac/IO
01 Dec 1988	01 Jun 1989	CVW-14	CV 64	F/A-18A	WestPac/IO
16 Sep 1989	19 Oct 1989	CVW-14	CV 64	F/A-18A/C	NorPac
23 Jun 1990	20 Dec 1990	CVW-14	CV 62	F/A-18C	WestPac/IO/ Persian Gulf

\* CVG-11 deployed to Korea embarked in *Philippine Sea* (CV 47) and on 29 March 1951 transferred to *Valley Forge* (CV 45) and returned to the States embarked in *Valley Forge*.



*A formation of squadron A-7E Corsair IIs in 1971.*

### Air Wing Assignments

<i>Air Wing</i>	<i>Tail Code</i>	<i>Assignment Date</i>
CVAG-11/CVG-11/-		
CVW-11*	V/NH†	15 Jul 1948
CVW-9	NG	1966
COMFAIRALAMEDA		Aug 1968
CVW-3	AC	1969
CVW-2	NE	01 Jun 1970
COMLATWING-		
PAC/VFA-125		1983
CVW-14	NK	Feb 1984

\* CVAG-11 was redesignated CVG-11 on 1 September 1948. CVG-11 was redesignated CVW-11 when Carrier Air Group (CVG) designations were redesignated Carrier Air Wings (CVW) on 20 December 1963.

† The tail code was changed from V to NH in 1957. The effective date for this change was most likely the beginning of FY 58 (1 July 1957).



*A squadron F/A-18A Hornet launching a Sparrow missile, 1984.*

### Unit Awards Received

<i>Unit Award</i>	<i>Inclusive Dates Covering Unit Award</i>		
NUC	04 Aug 1950	29 Mar 1951	
	26 Dec 1965	14 May 1966	
	18 Dec 1966	20 Jun 1967	
	22 Feb 1968	26 Jun 1968	
	02 Aug 1990	01 Nov 1990	
KSM	01 Aug 1950	29 Mar 1951	
	20 Jan 1952	12 Jul 1952	
KPUC	01 Aug 1950	29 Mar 1951	
	20 Jan 1952	12 Jul 1952	
NAVE	01 Jul 1957	30 Jun 1958	
	01 Jul 1967	30 Jun 1968	
	01 Jan 1985	30 Jun 1986	
MUC	18 Nov 1970	10 Jun 1971	
	27 Mar 1983	27 Aug 1985	
	01 Jan 1984	24 Aug 1985	
	30 Aug 1958	01 Sep 1958	
AFEM	03 Sep 1958	27 Sep 1958	
	15 Oct 1958	16 Oct 1958	
	21 Oct 1958	29 Oct 1958	
	15 Nov 1962	16 Nov 1962	
	20 Dec 1962		
	19 May 1964	10 Jun 1964	
	23 Jan 1968	22 Mar 1968	
	05 Aug 1990	04 Nov 1990	
SASM	25 Nov 1965	23 Dec 1965	
	15 Jan 1966	04 Feb 1966	
	18 Feb 1966	14 Mar 1966	
	01 Apr 1966	29 Apr 1966	
	08 May 1966	23 May 1966	
	17 Dec 1966	17 Jan 1967	
	31 Jan 1967	03 Mar 1967	
	20 Mar 1967	18 Apr 1967	
	28 Apr 1967	28 May 1967	
	04 Jun 1967	21 Jun 1967	
	VNSM		

### Unit Awards Received—Continued

<i>Unit Award</i>	<i>Inclusive Dates Covering Unit Award</i>	
RVNGC	21 Feb 1968	17 Mar 1968
	26 Mar 1968	24 Apr 1968
	30 Apr 1968	21 May 1968
	30 May 1968	27 Jun 1968
	18 Nov 1970	18 Dec 1970
	27 Dec 1970	13 Jan 1971
	02 Feb 1971	17 Mar 1971
	31 Mar 1971	18 Apr 1971
	25 Apr 1971	18 May 1971
	09 Dec 1972	03 Jan 1973
RVNGC	14 Jan 1973	30 Jan 1973
	01 Feb 1973	06 Feb 1973
	22 Dec 1966	
	04 Jan 1967	
	07 Jan 1967	09 Jan 1967
	12 Jan 1967	13 Jan 1967
	16 Jan 1967	
	20 Feb 1967	
	21 Feb 1967	
	23 Feb 1967	
	25 Feb 1967	
	01 Mar 1967	
	23 Mar 1967	
	27 Mar 1967	
14 Apr 1967	15 Apr 1967	
RVNGC	29 Apr 1967	
	10 Jun 1967	
	22 Feb 1968	24 Feb 1968
	26 Feb 1968	03 Mar 1968
	05 Mar 1968	08 Mar 1968
	12 Mar 1968	
	14 Mar 1968	
	16 Mar 1968	
	29 Mar 1968	

**Unit Awards Received—Continued**

<i>Unit Award</i>	<i>Inclusive Dates Covering Unit Award</i>	
	01 Apr 1968	05 Apr 1968
	07 Apr 1968	10 Apr 1968
	12 Apr 1968	
	14 Apr 1968	
	16 Apr 1968	20 Apr 1968
	22 Apr 1968	23 Apr 1968
	02 May 1968	
	13 May 1968	
	01 Jun 1968	02 Jun 1968
	04 Jun 1968	

**Unit Awards Received—Continued**

<i>Unit Award</i>	<i>Inclusive Dates Covering Unit Award</i>	
	15 Jun 1968	
HSM	25 May 1976	01 Jun 1976
	20 Mar 1981	
NEM	30 Oct 1980	12 Mar 1981
	27 Jun 1987	23 Jul 1987
VA-113 Det Q		
AFEM	19 May 1965	20 May 1965
	25 May 1965	26 May 1965
VNSM	26 Jul 1965	17 Aug 1965
	27 Aug 1965	10 Sep 1965



*A squadron F/A-18C Hornet in flight, circa 1990.*

## VFA-125

### Lineage

Established as Fighter Attack Squadron ONE HUNDRED TWENTY FIVE (VFA-125) on 13 November 1980.

The Fighter Attack designation was changed to Strike Fighter on 25 March 1983. However, the VFA acronym remained the same. It is the first squadron to be assigned the VFA-125 designation.



The squadron's first insignia was approved in 1980 using the old design from VA-125.



A modification to the squadron's insignia was approved in 1991, adding two horizontal lines and changing the designation in the scroll.

### Squadron Insignia and Nickname

The squadron's insignia was approved by CNO on 3 October 1980. The squadron adopted the insignia that had been used by VA-125. Colors for the torch insignia are: a black background outlined in gray; yellow scroll with black lettering and a gray outline; white torch with gray outlines; yellow flame outlined in gray followed by red, outlined in gray; gray electron rings.

CNO approved a modification to the squadron's insignia on 29 January 1991. The gray colors were changed to a light blue and a red and dark blue horizontal strip was added to the lower part of the insignia.

Nickname: Rough Raiders, 1980-present.

### Chronology of Significant Events

13 Nov 1980: The squadron was established with a mission of training fighter and attack pilots to fly the F/A-18 Hornet. It was also tasked with training Navy and Marine Corps maintenance personnel. The commanding officer was a naval officer and the executive officer a Marine Corps officer.

Jun 1981: Squadron's officers, along with the F/A-18, participated in the Paris Air Show.

Aug 1982: The squadron achieved a "Ready for Training" status and VMFA-314 became the first

squadron to begin transition training in the F/A-18.

Sep 1982: The squadron's first carrier qualification detachment began operations aboard *Constellation* (CV 64).

Mar 1983: Training began for the first Navy squadron to transition to the F/A-18.



Squadron F/A-18 Hornets on the flight line at NAS Lemoore, California.

### Home Port Assignments

Location	Assignment Date
NAS Lemoore	13 Nov 1980

### Commanding Officers

	Date Assumed Command
CDR James W. Partington	13 Nov 1980
CDR Jerry D. Palmer	24 Jun 1982
CDR John A. Lockard	14 Oct 1983
CDR Dennis V. McGinn	14 Dec 1984
CDR W. W. Pickavance, Jr.	13 Mar 1986
CDR John C. Leslie, Jr.	15 Jun 1987
CDR Joseph W. Parker, Jr.	02 Sep 1988
CDR Alan R. Gorthy, Jr.	01 Dec 1989
CDR David C. Kendall	08 Mar 1991

### Aircraft Assignment

Type of Aircraft	Date Type First Received
F/A-18A	19 Feb 1981
TF/A-18A	10 Mar 1981
A-7E	12 Mar 1981
O-2A	Apr 1986
F/A-18B	May 1986
F/A-18D	Jul 1988
F/A-18C	1988
T-34C	1990

**Air Wing Assignments**

<i>Air Wing</i>	<i>Tail Code</i>	<i>Assignment Date</i>
COMLATWINGPAC	NJ	13 Nov 1980

**Unit Awards Received**

<i>Unit Award</i>	<i>Inclusive Dates Covering Unit Award</i>
MUC	13 Nov 1980      28 Mar 1983



*A formation of squadron F/A-18 Hornets, including the two-seat versions (Courtesy Duane Kasulka Collection).*

## VFA-127

### Lineage

Established as Attack Squadron ONE HUNDRED TWENTY SEVEN (VA-127) on 15 June 1962.

Redesignated Strike Fighter Squadron ONE HUNDRED TWENTY SEVEN (VFA-127) on 1 March 1987. The first squadron to be assigned the VA-127 and VFA-127 designations.

### Squadron Insignia and Nickname

The squadron's first insignia was approved by CNO on 4 February 1963. Colors for the bat and torch insignia were: white and black background outlined in red; black and white bat; white torch outlined in black with a yellow and red flame, also outlined in black; white scroll outlined in black with black lettering.



*The bat and torch design was the first insignia approved for use by the squadron.*

A new insignia was approved by CNO on 4 June 1975. Colors for the globe and serpent design were: a light blue background outlined in dark blue; blue and green globe with black latitude and longitude lines; yellow lightning bolts outlined in black and red; black and yellow serpent with red tongue and fangs; the open book was white with yellow and black markings; black and white aircraft carrier; black plane with dark blue contrail; red and black international date line; light blue scroll outlined in dark blue with black lettering.

On 17 December 1975 CNO approved the squadron's request to return to its original bat and torch insignia.



*In June 1975, CNO approved the use of the globe and serpent insignia for the squadron. However, this design was used only for the remainder of 1975 and then the squadron requested approval to revert back to its first design, the bat and torch. This request was approved by CNO in December 1975.*



*The next insignia approved and used by the squadron was the red star design.*



*In 1984, a modification was made to the red star insignia adding an upper scroll and wording that identified the mission of the squadron. When the squadron was redesignated VFA in 1987, the Attack Squadron 127 designation in the lower scroll changed to Strike Fighter Squadron 127.*

A new insignia was approved by CNO on 10 August 1980. Colors for the red star insignia were: a gray background outlined in black, red and black lines; a red star outlined in white and red; gray aircraft with a black canopy; yellow compass markings; gray scroll outlined in black with black lettering.

A modification to the red star insignia was approved by CNO on 25 October 1984. This modification added an upper scroll with Pacific Fleet Adversary in black lettering.

Nickname: Royal Blues, 1960s–1980.  
Cylons, 1981–present.

### Chronology of Significant Events

**24 Jul 1961–15 Jun 1962:** Prior to being established as VA-127, the unit operated as VA-126 Det Alfa with a mission to provide basic and refresher all-weather jet instrument and transition training for pilots on the west coast.

**15 Jun 1962:** The squadron's primary mission was to provide advanced all-weather jet instrument training for fleet replacement pilots and refresher training for light jet attack pilots. A secondary mission included jet transition and refresher training.

**1 Jun 1970:** The squadron's mission was modified when it was designated as the only A-4 Replacement Air Wing squadron in the Navy. The primary mission included fleet replacement pilot training, basic and refresher all weather jet instrument training and replacement enlisted training in both the TA-4 and A-4 model aircraft, plus the ancillary mission of providing jet transition training. The flight syllabus included weapons delivery (conventional and nuclear), airborne electronic countermeasures, field mirror landing practice, low level navigation, inflight aerial refueling, defensive tactics and carrier qualifications (day and night).

**Apr 1971:** The squadron expanded its training on the A-4 to include personnel from the Argentine Navy, previously only U.S. naval aviators had been trained by the squadron.

**1973:** The squadron continued its program of pro-



viding training on the A-4 to foreign pilots. Beginning in 1973 pilot training for the Singapore Air Defense Command was conducted by VA-127.

**Jul 1975:** The squadron's primary mission was changed. Fleet Replacement Pilot training and the Fleet Replacement Aviation Maintenance Program were discontinued. The squadron's new missions included basic refresher all weather jet instrument training, air combat maneuvering adversary training, foreign pilot training and jet transition/refresher training. In November 1975 CNO officially designated VA-127 with the mission of air combat maneuvering (ACM) adversary training.

**1 Oct 1983:** The squadron's instrument training mission was dropped and the primary mission became the Adversary Role (Dissimilar Air Combat Maneuvering).



*A squadron F9F-8T (TF-9J) Cougar at NAS Lemoore, California, July 1963 (Courtesy Robert Lawson Collection).*

### **Home Port Assignments**

<i>Location</i>	<i>Assignment Date</i>
NAS Lemoore	15 Jun 1962
NAS Fallon	01 Oct 1987

### **Commanding Officers**

	<i>Date Assumed Command</i>
CDR Emory G. Tiffany	15 Jun 1962
CDR Simpson Evans, Jr.	19 Oct 1962
CDR William F. McCullough	13 Sep 1963
CDR J. R. Harper	25 Sep 1964
CDR W. S. Brown	17 Sep 1965
CDR J. C. Duck	02 Sep 1966
CDR Edward W. V. Webster	05 May 1967
CDR Timothy J. Perry	12 Jul 1968
CDR Loren M. Dierdorff	13 Jun 1969
CDR Lawrence A. Sharpe	05 Jun 1970
CDR George E. Sheldon, Jr.	14 May 1971
CDR Thomas W. Poore	12 May 1972
CDR Cecil Richard Tulley	31 May 1973
CDR Ronald M. Shields	Aug 1974
CDR Arvin R. Chauncey	10 Oct 1975
CDR Ronald L. Waters	21 Dec 1976
CDR Gary L. Beck	08 Mar 1978
CDR John A. McAuley, Jr.	03 Aug 1979
CDR Donald L. Dill	26 Nov 1980
CDR Wiley P. DeCarli	26 Feb 1982
CDR Paul J. Valovich	26 May 1983
CDR Michael J. Sullivan	30 Nov 1984
CDR David R. Olson	30 May 1986
CDR Ridgeway W. Corbin II	20 Nov 1987
CDR Alan R. Gorthy, Jr.	05 Dec 1988
CDR Gary A. Barrett	20 Oct 1989
CDR Vance L. Toalson	11 Jan 1991

*Two squadron TA-4F Skyhawks in flight, 1967.*



**Aircraft Assignment**

<i>Type of Aircraft</i>	<i>Date Type First Received</i>
F9F-8T/TF-9J*	15 Jun 1962
TA-4F	03 Aug 1966
A-4F	Mar 1970
A-4E	Apr 1970
TA-4J	15 Apr 1971
T-38B	Sep 1987

**Aircraft Assignment—Continued**

<i>Type of Aircraft</i>	<i>Date Type First Received</i>
QT-38A	Sep 1987
F-5E	Sep 1987
F-5F	Sep 1987
F/A-18A	Mar 1992

\* The F9F-8T designation was changed to TF-9J in 1962.



*Three squadron TA-4J Skyhawks fly in formation with one of the squadron's A-4F Skyhawks, 1983.*



*A squadron F-5E Tiger II at NAS Fallon, Nevada, July 1989 (Courtesy Robert Lawson Collection).*

### Air Wing Assignments

<i>Air Wing</i>	<i>Tail Code</i>	<i>Assignment Date</i>
RCVG-12/RCVW-12*	NJ†	15 Jun 1962
COMFAIRLEMOORE/ COMLATWINGPAC/ COMSTRKFIGHT- WINGPAC‡		01 Jun 1970

\* Replacement Air Groups were redesignated Combat Readiness Air Groups on 1 April 1963. They were popularly known by the short titles RAG and CRAG in the respective periods, but the designation throughout was RCVG. On 20 December 1963, when Carrier Air Group (CVG) designations were changed to Carrier Air Wings (CVW) the RCVG designation was changed to RCVW.

† RCVW-12 was disestablished on 1 June 1970. However, VA-127, and the other squadrons assigned to RCVW-12, continued to use the NJ tail code.

‡ COMFAIRLEMOORE was redesignated COMLATWINGPAC on 30 June 1973 and in 1991 redesignated COMSTRKFIGHTWINGPAC.



*A squadron F/A-18A Hornet at NAS Fallon, Nevada, 1992 (Courtesy Robert Lawson Collection).*

## VFA-131

### Lineage

Established as Strike Fighter Squadron ONE HUNDRED THIRTY ONE (VFA-131) on 3 October 1983.

The first squadron to be assigned the VFA-131 designation.

### Squadron Insignia and Nickname

The squadron's insignia was approved by CNO on 26 January 1984. Colors for the insignia are: a blue background outlined in white and blue; white stars and aircraft; red, white and blue contrail outlined in white; white wildcat head with black markings, black nose, red eye and mouth; blue scroll with white lettering.



The squadron's Wildcat insignia.

Nickname: Wildcats, 1984-present.

### Chronology of Significant Events

**Mar 1986:** During Freedom of Navigation exercises in the Gulf of Sidra, the squadron's aircraft flew Combat Air Patrols in support of the exercise, including the period of 24 and 25 March following a Libyan firing of an SA-5 missile on 24 March against an American aircraft operating in international waters.

**14-15 Apr 1986:** Squadron aircraft, along with other units of CVW-13 and A-7s from CVW-1, provided air-to-surface Shrike and Harm missile strikes against Libyan surface-to-air missile sites at Banghazi. This was the first use of the F/A-18 in combat.

**15 Aug-8 Oct 1988:** Squadron was embarked in *Independence* (CV 62) during the carrier's transit, via Cape Horn, from Norfolk to its new home port at San Diego.

**Aug 1990:** Embarked in *Eisenhower* (CVN 69), the squadron's F/A-18s flew missions in the Red Sea in support of Operation Desert Shield, the build-up of American and Allied forces to counter a threatened invasion of Saudi Arabia by Iraq and as part of an economic blockade of Iraq to force its withdrawal from Kuwait. The *Eisenhower* task force was the first U.S. force in position to deter Iraqi incursion into Saudi Arabia.

### Home Port Assignments

Location	Assignment Date
NAS Lemoore	03 Oct 1983
NAS Cecil Field	15 Apr 1985*

\*This is the official transfer date, however, the squadron had aircraft and personnel onboard the air station in February 1985.

### Commanding Officers

	Date Assumed Command
CDR James O. Ellis, Jr.	03 Oct 1983
CDR Charles W. Moore, Jr.	02 Dec 1985
CDR Dean L. Steele	05 Jun 1987
CDR Jerry B. Singleton	01 Dec 1988
CDR Robert C. Rubel	20 Jun 1990
CDR R. E. Hoppock	18 Sep 1991

### Aircraft Assignment

Type of Aircraft	Date Type First Received
F/A-18A	May 1984
F/A-18C	05 Nov 1990



A squadron F/A-18C Hornet on the deck of George Washington (CVN 73), September 1993.

**Major Overseas Deployments**

<i>Date of Departure</i>	<i>Date of Return</i>	<i>Air Wing</i>	<i>Carrier</i>	<i>Type of Aircraft</i>	<i>Area of Operation</i>
02 Oct 1985	19 May 1986	CVW-13	CV 43	F/A-18A	Med
29 Sep 1987	28 Mar 1988	CVW-13	CV 43	F/A-18A	Med
08 Mar 1990	12 Sep 1990	CVW-7	CVN 69	F/A-18A	Med/Red Sea

**Air Wing Assignments**

<i>Air Wing</i>	<i>Tail Code</i>	<i>Assignment Date</i>
COMLATWINGPAC		03 Oct 1983
CVW-13	AK	01 Mar 1984
CVW-17	AA	05 May 1988
CVW-7	AG	17 Oct 1988

**Unit Awards Received**

<i>Unit Award</i>	<i>Inclusive Dates Covering Unit Award</i>	
NEM	20 Jan 1986	05 May 1986
NAVE	01 Jan 1986	31 Dec 1986
NUC	02 Oct 1985	19 May 1986
	23 Mar 1986	17 Apr 1986
MUC	08 Mar 1990	12 Sep 1990
AFEM	12 Apr 1986	17 Apr 1986
SASM	08 Aug 1990	24 Aug 1990



*A formation of squadron F/A-18A Hornets, 1986.*

## VFA-132

### Lineage

Established as Strike Fighter Squadron ONE HUNDRED THIRTY TWO (VFA-132) on 3 January 1984.

Disestablished on 1 June 1992. The first squadron to be assigned the VFA-132 designation.

### Squadron Insignia and Nickname

The squadron's insignia was approved by CNO on 2 May 1985. Colors for the privateer insignia were: a



The squadron's one and only insignia.

light blue background outlined in yellow; the privateer's coat was red with yellow trim; black boots; black hat with yellow trim; white trousers; the man's face and hands were white and his mustache and eye patch were black; white rockets and green bombs, both outlined in black; yellow contrails from the rockets and bombs; white cutlass

outlined in black with a yellow handle; dark blue scrolls with yellow lettering.

Nickname: Privateers, 1984–1992.

### Chronology of Significant Events

**Mar 1986:** During Freedom of Navigation exercises in the Gulf of Sidra, the squadron's aircraft flew Combat Air Patrols in support of the exercise, including the period of 24 and 25 March following a 24 March Libyan firing of an SA-5 missile against an American aircraft operating in international waters.

**14–15 Apr 1986:** Squadron aircraft, along with other

units of CVW-13 and A-7s from CVW-1, provided air-to-surface Shrike and Harm missile strikes against Libyan surface-to-air missile sites at Benghazi. This was the first use of the F/A-18 in combat.

**Oct 1987–Apr 1988:** The squadron deployed to MCAS Iwakuni, Japan, and was assigned to Marine Air Group 15. While deployed to Japan, the squadron operated detachments at NAS Cubi Point, Tsuiki AB, Clark AB, Yechon AB, Misawa AB and Kadena AB.

**Aug–Sep 1989:** *Coral Sea* (CV 43), with VFA-132 embarked, operated off the coast of Lebanon following the Israeli capture of Sheik Obeid and the reported killing of Lieutenant Colonel William R. Higgins, USMC. In early September the squadron provided air cover for the CH-53 helos used to evacuate personnel from the U.S. embassy in Beirut.

**Jun–Sep 1991:** CVW-6 squadrons participated in Operation Provide Comfort, flying missions over northern Iraq in support of the Kurdish relief effort.

### Home Port Assignments

Location	Assignment Date
NAS Lemoore	03 Jan 1984
NAS Cecil Field	Feb 1985

### Commanding Officers

	Date Assumed Command
CDR Robert E. Lakari	10 Jan 1984
CDR John B. Nathman	22 Apr 1985
CDR Scott C. Ronnie	1986
CDR John T. Morris	01 Oct 1987
CDR Robert C. Stephens	05 May 1989
CDR J. L. Fleming	13 Sep 1990

### Aircraft Assignment

Type of Aircraft	Date Type First Received
F/A-18A	21 Jun 1984



Two squadron F/A-18A Hornets preparing to launch from *Coral Sea* (CV 43), January 1986.

**Major Overseas Deployments**

<i>Date of Departure</i>	<i>Date of Return</i>	<i>Air Wing</i>	<i>Carrier</i>	<i>Type of Aircraft</i>	<i>Area of Operation</i>
02 Oct 1985	19 May 1986	CVW-13	CV 43	F/A-18A	Med
05 Oct 1987	28 Apr 1988	MAG-15	MCAS Iwakuni	F/A-18A	Japan/WestPac
31 May 1989	30 Sep 1989	CVW-13	CV 43	F/A-18A	Med
30 May 1991	22 Dec 1991	CVW-6	CV 59	F/A-18A	Med

**Air Wing Assignments**

<i>Air Wing</i>	<i>Tail Code</i>	<i>Assignment Date</i>
CVW-13	AK	01 Mar 1984
MAG-15		Oct 1987
CVW-13	AK	May 1988
CVW-6	AE	01 Oct 1990

**Unit Awards Received**

<i>Unit Award</i>	<i>Inclusive Dates Covering Unit Award</i>	
NEM	20 Jan 1986	05 May 1986
NUC	02 Oct 1985	19 May 1986
	23 Mar 1986	17 Apr 1986
MUC	30 Mar 1988	30 Sep 1989
AFEM	12 Apr 1986	17 Apr 1986
JMUA	Jun 1991	Sep 1991



*A close-up of a squadron F/A-18A in flight.*

## VFA-136

### Lineage

Established as Strike Fighter Squadron ONE HUNDRED THIRTY SIX (VFA-136) on 1 July 1985.

The first squadron to be assigned the VFA-136 designation.

### Squadron Insignia and Nickname



The squadron's *Knighthawks* insignia.

The squadron's insignia was approved by CNO on 23 May 1985. Colors for the Knight-hawk insignia are: a light blue background outlined in dark blue; black shield outlined in red; blue-white hawk with black markings; yellow feet and beak; black eye; light blue scrolls outlined in dark blue with black lettering.

Nickname: Knight-hawks, 1985-present.

### Chronology of Significant Events

Aug 1990: Embarked in *Eisenhower* (CVN 69), the squadron's F/A-18s flew missions in the Red Sea in support of Operation Desert Shield, the build-up of American and Allied forces to counter a threatened invasion of Saudi Arabia by Iraq and as part of an economic blockade of Iraq to force its withdrawal from Kuwait. The *Eisenhower* task force was the first U.S. force in position to deter Iraqi incursions into Saudi Arabia.

### Home Port Assignments

Location	Assignment Date
NAS Lemoore	01 Jul 1985
NAS Cecil Field	28 Mar 1986

### Commanding Officers

	Date Assumed Command
CDR G. A. Gurick	01 Jul 1985
CDR M. D. Malone	24 Aug 1987
CDR John B. Sandknop	11 Mar 1989
CDR Jeffrey R. Nelson	20 Sep 1990
CDR D. R. Miller	14 Dec 1991

### Aircraft Assignment

Type of Aircraft	Date Type First Received
F/A-18A	07 Jan 1986
F/A-18C	13 Nov 1990



A squadron F/A-18A Hornet about to be launched from *Eisenhower* (CVN 69).



A squadron F/A-18A Hornet in flight, circa 1986 or 1987.



**Major Overseas Deployments**

<i>Date of Departure</i>	<i>Date of Return</i>	<i>Air Wing</i>	<i>Carrier</i>	<i>Type of Aircraft</i>	<i>Area of Operation</i>
29 Sep 1987	28 Mar 1988	CVW-13	CV 43	F/A-18A	Med
08 Mar 1990	12 Sep 1990	CVW-7	CVN 69	F/A-18A	Med/Red Sea
26 Sep 1991	02 Apr 1992	CVW-7	CVN 69	F/A-18C	Med/IO/NorLant

**Air Wing Assignments**

<i>Air Wing</i>	<i>Tail Code</i>	<i>Assignment Date</i>	<i>Unit Award</i>	<i>Inclusive Dates Covering Unit Award</i>	
CVW-13	AK	10 Jun 1986	MUC	08 Mar 1990	12 Sep 1990
CVW-7	AG	01 Oct 1988	SASM	08 Aug 1990	24 Aug 1990

**Unit Awards Received**

*A squadron F/A-18A Hornet in flight armed with a Sidewinder missile on its wing tip, February 1989.*

## VFA-137

### Lineage

Established as Strike Fighter Squadron ONE HUNDRED THIRTY SEVEN (VFA-137) on 1 July 1985.

The first squadron to be assigned the VFA-137 designation.

### Squadron Insignia and Nickname

The squadron's insignia was approved by CNO on 1



The squadron's stylized hawk design was approved by CNO in April 1985.

April 1985. Colors for the stylized hawk design are: a black background outlined in orange; the upper part of the hawk design is white and the lower part is reddish-brown; gray beak outlined in black; yellow eye with a black pupil; grayish-blue contrails; orange stylized aircraft; black scrolls outlined in orange and the lettering is orange.

Nickname: Kestrels, 1985-present.

### Chronology of Significant Events

Aug–Sep 1989: *Coral Sea* (CV 43), with VFA-137 embarked, operated off the coast of Lebanon following the Israeli capture of Sheik Obeid and the reported killing of Lieutenant Colonel William R. Higgins, USMC. Squadron aircraft flew air support (Combat Air Patrols) during this crisis and the evacuation personnel from the U.S. embassy in Beirut.

### Home Port Assignments

Location	Assignment Date
NAS Cecil Field	01 Jul 1985

### Commanding Officers

	Date Assumed Command
CDR Raymond E. Thomas	01 Jul 1985
CDR Barry J. Dysart	03 Sep 1987
CDR Philip G. Howard	02 Mar 1989
CDR Craig B. Henderson	04 May 1990

### Aircraft Assignment

Type of Aircraft	Date Type First Received
F/A-18A	25 Nov 1985



A squadron F/A-18A Hornet about to trap on *Coral Sea* (CV 43), 1989.

**Major Overseas Deployments**

<i>Date of Departure</i>	<i>Date of Return</i>	<i>Air Wing</i>	<i>Carrier</i>	<i>Type of Aircraft</i>	<i>Area of Operation</i>
29 Sep 1987	28 Mar 1988	CVW-13	CV 43	F/A-18A	Med
31 May 1989	30 Sep 1989	CVW-13	CV 43	F/A-18A	Med

**Air Wing Assignments**

<i>Air Wing</i>	<i>Tail Code</i>	<i>Assignment Date</i>	<i>Unit Award</i>	<i>Inclusive Dates Covering Unit Award</i>	
CVW-13	AK	01 Jun 1986	NAVE	01 Jan 1987	31 Dec 1987
CVW-6	AE	01 Oct 1990	MUC	30 Mar 1988	30 Sep 1989

**Unit Awards Received**

*A squadron F/A-18A in flight, March 1991.*

## VFA-146

### Lineage

Established as Attack Squadron ONE HUNDRED FORTY SIX (VA-146) on 1 February 1956.

Redesignated Strike Fighter Squadron ONE HUNDRED FORTY SIX (VFA-146) on 21 July 1989. This is the first squadron in the Navy to be assigned the designation VA-146 and VFA-146.

### Squadron Insignia and Nickname

The first insignia for VA-146 was approved by CNO on 23 November 1956. This design consisted of two concentric circles.



*The globe and mach wave symbol was part of the squadron's first insignia.*

Emanating from North America was a 300 degree arc in black. The mach wave and arc from North America symbolized the range and striking power of the squadron.

The first nickname the squadron reported to have used was Blacktails. This name was in reference to the black color assigned to the squadron's position in the air group. The nickname Blue Diamonds was adopted by the squadron sometime in the late 1950s. In 1968 the squadron elected to simplify their insignia and



*The squadron's insignia was modified and approved for use by CNO in 1968. When the squadron was designated VFA, the designation in the scroll was changed from VA-146 to VFA-146.*

bring it in concert with their nickname. Their insignia was revised and approved by CNO on 29 August 1968. The new insignia kept the old design of two concentric circles with an outer circle of dark blue and the inner circle of light blue. Superimposed on the two circles was the yellow mach wave and four dark blue diamonds. Attached to the lower part of the insignia was a scroll

outlined in dark blue with a light blue background and lettering in yellow.

Nickname: Blacktails, 1956-late 1950s.

Blue Diamonds, late 1950s-present.

### Chronology of Significant Events

**17–21 Jan 1960:** VA-146 squadron aircraft participated in a coast to coast non-stop cross country flight.

**8 Jun–13 Jul 1964:** The Blue Diamonds participated in Yankee Team Operations. These operations involved photo reconnaissance missions over Laos. The squadron's A-4C Skyhawks were used to provide tanker and rocket-armed escort support for the photo reconnaissance sorties over Laos and South Vietnam. This type of support was also provided by the squadron during the period 15 August to 20 September 1964.

**4–5 Aug 1964:** Aircraft from VA-146 flew night sorties in support of Desoto Patrol operations conducted by American destroyers operating in international waters off the coast of North Vietnam. These sorties were the result of attacks conducted against *Maddox* (DD 731) by North Vietnamese motor torpedo boats on 2 August 1964. The American destroyer had been conducting Desoto Patrol operations when this incident occurred. Desoto Patrol operations involved the collection of signal intelligence.

**5 Aug 1964:** VA-146 aircraft participated in Operation Pierce Arrow. This operation involved retaliatory air strikes against North Vietnamese torpedo boats and their bases and supporting facilities because of the attacks against the *Maddox* (DD 731) and *Turner Joy* (DD 951) on 4 August by North Vietnamese motor torpedo boats. VA-146's A-4Cs flew 8 sorties against two installations. They experienced heavy antiaircraft ground fire but none of their aircraft were damaged. The sorties by VA-146 and the other



*A squadron F9F-8 Cougar trapping aboard Hornet (CVA 12), March 1957 (Courtesy Robert Lawson Collection).*

units of CVW-14 against Hon Gay and the torpedo boats operating near Hon Me Island resulted in the sinking or damaging of 8 torpedo boats.

**5 Aug 1964:** VA-146 was one of the first squadrons to employ the A-4C in combat.

**29 Jun 1966:** CDR Schaufelberger led a 28 plane strike of VA-146 and other CVW-14 aircraft against the Haiphong POL complex. This was the first American strike against this complex.

**30 Sep 1967:** CDR Robert F. Dunn was awarded a Silver Star for his actions on this date.

**16 Jun 1969:** While operating on Yankee Station aboard *Enterprise*, the carrier was ordered north to the Sea of Japan in response to an international incident involving the shoot down of a Navy EC-121 by the North Korean Air Force.

**Apr 1970:** The squadron flew across the country to board an east coast based carrier, *America* (CVA 66), for an extended combat deployment to Vietnam.

**May 1970:** CDR Stephens, along with other pilots from VA-147, flew the newest update version of the A-7 Corsair II, the A-7E, into combat for the first time.

**Dec 1971:** During their second line period on Yankee Station, VA-146 became the first Navy squadron to use the laser-guided bomb (LGB) during combat in Southeast Asia.

**May 1972:** The squadron's A-7Es conducted the first night mining missions for the Corsair II E models when they flew combat mining sorties on North Vietnamese rivers.

**Feb-Apr 1973:** VA-146 acted as a deterrant force during Operation Endsweep, the sweeping of mines from North Vietnamese waters.

**Nov 1974:** VA-146, as part of the CVW-9 team aboard *Constellation*, operated in the Persian Gulf. This was the first time in 26 years that an American carrier had entered and operated in the Persian Gulf.



A squadron FJ-4B Fury on the elevator of Ranger (CVA 61) during her cruise to the Med in 1959.

**7 Mar 1979:** *Constellation* and her air wing were ordered to make a high speed transit to the Indian Ocean from the Philippines in response to the conflict between North and South Yemen.

**Feb-Oct 1980:** VA-146 made the first western Pacific deployment with the new Forward Looking Infrared Radar System (FLIR) installed on the A-7E Corsair II.

**1983:** The Blue Diamonds were tasked with fleet introduction of the HARM system. This new missile succeeds Shrike and ARM as the primary antiradiation, defense-suppression air-to-surface missile.

**Sep 1988:** *Nimitz* (CVN 68), with VA-146 embarked, operated in the Sea of Japan in support of the Summer Olympic Games in Seoul, Republic of Korea.

### Home Port Assignments

Location	Assignment Date
NAS Miramar	01 Feb 1956
NAS Lemoore	15 May 1962

### Commanding Officers

	Date Assumed Command
CDR E. V. Davidson	01 Feb 1956
CDR J. R. Kincaid	30 Aug 1957
LCDR W. W. Alldredge	29 Aug 1958
CDR G. S. Hodgson	12 Aug 1959
LCDR J. R. Faulk	28 Dec 1960
CDR R. G. Hanecak	12 Oct 1961
CDR J. D. Ingram	09 Mar 1963
CDR E. V. Crangle	28 Oct 1963
CDR W. H. Harris	20 Nov 1964
CDR H. B. Loheed	03 Dec 1965
CDR A. A. Schaufelberger	01 Feb 1966
CDR R. F. Dunn	25 Jan 1967
CDR P. E. Johnson	14 Nov 1967
CDR Ford J. E. Schultz	13 Feb 1968
CDR Jesse R. Emerson III	18 Feb 1969
CDR Wayne L. Stephens	19 Dec 1969
CDR Manual B. Sousa	29 Jan 1971
CDR John A. Miller	07 Dec 1971
CDR O. F. Baldwin	15 Dec 1972
CDR D. K. Tyler	28 Mar 1974
CDR L. A. Sanders	11 Jun 1975
CDR R. I. Howson	16 Sep 1976
CDR L. H. Price	14 Dec 1977
CDR J. A. Lair	04 Nov 1978
CDR L. J. Vernon	26 Feb 1980
CDR W. S. Orr	22 Apr 1981
CDR M. G. Shaw	09 Jul 1982
CDR P. C. Campbell	01 Dec 1983
CDR G. N. Crim, Jr.	14 Jun 1985
CDR R. E. Arnott	30 Sep 1986
CDR David C. Kendall	11 Mar 1988
CDR Phillip H. Mills	21 Jul 1989
CDR Steven E. Davis	02 Nov 1990



*A formation of squadron FJ-4B Furys, 1961.*

**Aircraft Assignment**

<i>Type of Aircraft</i>	<i>Date Type First Received</i>
F9F-8	Feb 1956
F9F-6	Feb 1956
F9F-5	Feb 1956
FJ-4B	04 Sep 1957
A4D-2N/A-4C*	06 Jun 1962

**Aircraft Assignment—Continued**

<i>Type of Aircraft</i>	<i>Date Type First Received</i>
A-7B	04 Jun 1968
A-7E	20 Sep 1969
F/A-18C	18 Nov 1989

\* The A4D-2N designation was changed to A-4C in 1962.



*A squadron A-4C Skyhawk and a VA-144 Skyhawk on Constellation's (CVA 64) elevator during her combat deployment to Vietnam in 1964–1965.*

**Major Overseas Deployments**

<i>Date of Departure</i>	<i>Date of Return</i>	<i>Air Wing</i>	<i>Carrier</i>	<i>Type of Aircraft</i>	<i>Area of Operation</i>
21 Jan 1957	25 Jul 1957	CVG-14	CVA 12	F9F-8/8B	WestPac
27 May 1958	20 Aug 1958	CVG-14	CVA 61	FJ-4B	SoLant
03 Jan 1959	27 Jul 1959	CVG-14	CVA 61	FJ-4B	WestPac
14 May 1960	15 Dec 1960	CVG-14	CVA 34	FJ-4B	WestPac
09 Nov 1961	12 May 1962	CVG-14	CVA 16	FJ-4B	WestPac
21 Feb 1963	10 Sep 1963	CVG-14	CVA 64	A-4C	WestPac
05 May 1964	01 Feb 1965	CVW-14	CVA 64	A-4C	WestPac/Vietnam
10 Dec 1965	25 Aug 1966	CVW-14	CVA 61	A-4C	WestPac/Vietnam
29 Apr 1967	04 Dec 1967	CVW-14	CVA 64	A-4C	WestPac/Vietnam
06 Jan 1969	02 Jul 1969	CVW-9	CVAN 65	A-7B	WestPac/Vietnam
10 Apr 1970	21 Dec 1970	CVW-9	CVA 66	A-7E	WestPac/Vietnam
01 Oct 1971	30 Jun 1972	CVW-9	CVA 64	A-7E	WestPac/Vietnam
05 Jan 1973	11 Oct 1973	CVW-9	CVA 64	A-7E	WestPac/Vietnam
21 Jun 1974	22 Dec 1974	CVW-9	CVA 64	A-7E	WestPac/IO
12 Apr 1977	21 Nov 1977	CVW-9	CV 64	A-7E	WestPac
26 Sep 1978	17 May 1979	CVW-9	CV 64	A-7E	WestPac/IO
26 Feb 1980	15 Oct 1980	CVW-9	CV 64	A-7E	WestPac/IO
20 Oct 1981	23 May 1982	CVW-9	CV 64	A-7E	WestPac/IO
13 Jan 1984	01 Aug 1984	CVW-2	CV 63	A-7E	WestPac/IO
24 Jul 1985	21 Dec 1985	CVW-9	CV 63	A-7E	WestPac/IO
03 Jan 1987	29 Jun 1987	CVW-9	CV 63	A-7E	World Cruise
02 Sep 1988	27 Feb 1989	CVW-9	CVN 68	A-7E	WestPac/IO
15 Jun 1989	09 Jul 1989	CVW-9	CVN 68	A-7E	NorPac

**Air Wing Assignments**

<i>Air Wing</i>	<i>Tail Code</i>	<i>Assignment Date</i>
CVG-14/CVW-14†	A/NK*	01 Feb 1956
CVW-9	NG	Aug 1968
CVW-2	NE	12 Nov 1982
CVW-9	NG	15 Sep 1984

\* The tail code was changed from A to NK in 1957. The effective date for this change was most likely the beginning of FY 58 (1 July 1957).

† CVG-14 was redesignated CVW-14 when Carrier Air Group (CVG) designations were redesignated Carrier Air Wings (CVW) on 20 December 1963.



*A squadron A-7E Corsair II in flight alongside an A-6 Intruder, 1984.*

**Unit Awards Received**

<i>Unit Award</i>	<i>Inclusive Dates Covering Unit Award</i>	
AFEM	09 Oct 1960	12 Oct 1960
	20 Dec 1961	21 Dec 1961
	28 Feb 1962	06 Mar 1962
	06 Jun 1964	13 Jul 1964
	04 Aug 1964	21 Sep 1964
	29 Oct 1964	23 Nov 1964
	20 Apr 1969	11 May 1969
	24 Sep 1970	26 Sep 1970
MUC	02 Nov 1988	05 Dec 1988
	26 May 1970	08 Nov 1970
	12 Mar 1979	19 Apr 1979

**Unit Awards Received—Continued**

<i>Unit Award</i>	<i>Inclusive Dates Covering Unit Award</i>	
NEM	17 May 1979	31 May 1980
	21 Jan 1987	17 May 1987
	12 Mar 1979	19 Apr 1979
	26 Apr 1980	04 Aug 1980
NUC	12 Aug 1980	19 Aug 1980
	02 Aug 1964	05 Aug 1964
	10 Jan 1966	06 Aug 1966
PUC	18 May 1967	26 Nov 1967
	22 Oct 1971	13 Jun 1972
RVNGC	24 Jan 1966	
	26 Jan 1966	27 Jan 1966
	30 Jan 1966	

**Unit Awards Received—Continued**

<i>Unit Award</i>	<i>Inclusive Dates Covering Unit Award</i>	
	04 Feb 1966	
	06 Feb 1966	
	24 Feb 1966	
	26 Feb 1966	28 Feb 1966
	04 Mar 1966	
	06 Mar 1966	12 Mar 1966
	20 Mar 1966	
	27 Apr 1966	28 Apr 1966
	01 May 1967	01 Nov 1967
	31 Mar 1969	03 Apr 1969
	05 Apr 1969	
	31 May 1969	16 Jun 1969
	30 Mar 1972	01 Jun 1972
VNSM	15 Jan 1966	12 Feb 1966
	23 Feb 1966	22 Mar 1966
	12 Apr 1966	09 May 1966
	30 May 1966	30 Jun 1966
	13 Jul 1966	06 Aug 1966
	08 Jun 1967	11 Jun 1967
	18 Jun 1967	25 Jul 1967
	01 Aug 1967	03 Sep 1967

**Unit Awards Received—Continued**

<i>Unit Award</i>	<i>Inclusive Dates Covering Unit Award</i>	
	25 Sep 1967	15 Oct 1967
	24 Oct 1967	12 Nov 1967
	30 Mar 1969	18 Apr 1969
	22 May 1969	24 May 1969
	29 May 1969	17 Jun 1969
	17 May 1970	
	19 May 1970	
	24 May 1970	16 Jun 1970
	28 Jun 1970	13 Jul 1970
	20 Jul 1970	04 Aug 1970
	24 Aug 1970	18 Sep 1970
	13 Oct 1970	08 Nov 1970
	02 Nov 1971	22 Nov 1971
	29 Nov 1971	31 Dec 1971
	09 Jan 1972	03 Feb 1972
	09 Feb 1972	02 Mar 1972
	13 Mar 1972	23 Mar 1972
	07 Apr 1972	18 May 1972
	24 May 1972	25 May 1972
	31 May 1972	13 Jun 1972
	25 Feb 1973	14 Mar 1973
	19 Mar 1973	28 Mar 1973



*A squadron F/A-18C Hornet on the flight line at NAS Lemoore, California, December 1989.*



## VFA-147

### Lineage

Established as Attack Squadron ONE HUNDRED FORTY SEVEN (VA-147) on 1 February 1967.

Redesignated Strike Fighter Squadron ONE HUNDRED FORTY SEVEN (VFA-147) on 20 July 1989. The first squadron to be assigned the VA-147 and VFA-147 designations.

### Squadron Insignia and Nickname

The squadron's insignia was approved by CNO on 30 June 1967. Colors for Argonaut insignia are: a yellow background outlined in black with an inner circle of yellow and white; gray mythical flying animal with black markings and outlined in black with a red and white eye; white Argonaut with a gray breast plate and helmet, a red skirt and helmet plume, gray sword and the entire figure has black markings. At a later date, a lower scroll was added to the insignia. The scroll was red outlined in black with black lettering.

A modification to the insignia was approved by CNO on 22 December 1989. The color of the Argonaut's skirt, helmet plume and scroll were changed to orange and the mythical flying animal was given a twin tail.

Nickname: Argonauts, 1967-present.

*When the squadron was redesignated VFA, the only change to its insignia was the designation in the scroll and the addition of a twin tail on the mythical beast.*



*The squadron's Argonaut insignia was approved by CNO on 30 June 1967.*



*A formation of squadron A-7E Corsair IIs, circa 1975.*

### Chronology of Significant Events

**Dec 1967:** The squadron flew its first combat missions, striking targets in North Vietnam. This was the first introduction of the A-7 Corsair II in combat.

**Jan 1968:** The squadron flew support missions for the defenders during the siege at Khe Sanh, South Vietnam.

**Jan 1968:** *Ranger* (CVA 61), with VA-147 embarked, was operating on Yankee Station when it was ordered to the Sea of Japan following the capture of *Pueblo* (AGER 2) by the North Koreans on 23 January 1968. *Ranger* and VA-147 operated in the area until relieved on 5 March.

**Apr 1969:** Following the shoot down of a Navy EC-121 aircraft by the North Koreans on 15 April, *Ranger*, with VA-147 embarked, left Yankee Station and proceeded to the Sea of Japan for operations off the coast of Korea.

**Apr 1972:** The squadron participated in Operation Freedom Train, tactical air sorties against military and logistic targets in the southern part of North Vietnam. It also provided support for forces in South Vietnam following a massive invasion by North Vietnam on 1 April 1972.

**May 1972:** The squadron participated in the early phase of Operation Linebacker I, heavy air strikes against targets in North Vietnam above 20 degrees north latitude.

**29 Jan 1973:** The squadron's commanding officer, Commander T. R. Wilkinson, failed to return from a routine sortie off the coast of the Philippines.

**Mar-Jun 1973:** VA-147 provided aerial support during Operation End Sweep, the removal of mines in North Vietnamese waters.

**Nov 1974:** VA-147, part of the CVW-9 team embarked on *Constellation* (CVA 64), operated in the Persian Gulf. This was the first time in 26 years that an American carrier had entered and operated in the Persian Gulf.

**Mar 1979:** *Constellation*, with elements of VA-147 embarked, was ordered to make a high speed transit to the Indian Ocean from the Philippines in response to the conflict between North and South Yemen.

**Sep 1988:** *Nimitz* (CVN 68), with VA-147 embarked, operated in the Sea of Japan in support of the Summer Olympic Games in Seoul, Republic of Korea.



**Home Port Assignments**

<i>Location</i>	<i>Assignment Date</i>
NAS Lemoore	01 Feb 1967

**Commanding Officers**

	<i>Date Assumed Command</i>
CDR James C. Hill	01 Feb 1967
CDR W. Scott Gray III	21 Jun 1968
CDR Donald J. Duhrkopf	27 Mar 1969
CDR R. N. Livingston	13 Mar 1970
CDR W. T. Majors	29 Jan 1971
CDR T. R. Wilkinson	04 Feb 1972
CDR W. C. Smith	29 Jan 1973
CDR D. D. Smith	08 Mar 1974
CDR Bobby C. Lee	23 May 1975
CDR Paul B. Austin	30 Aug 1976
CDR Gary L. Harter	15 Dec 1977

**Commanding Officers—Continued**

	<i>Date Assumed Command</i>
CDR Philip S. Gubbins	03 Nov 1978
CDR David J. L'Herault	29 Jan 1980
CDR Frank C. Bledsoe	18 May 1981
CDR Eric Vanderpoel II	05 Aug 1982
CDR Christopher G. Gates	06 Jan 1984
CDR James H. Oliver	21 Jun 1985
CDR J. R. Hutchison	01 Jul 1986
CDR Terry R. Nolan	04 Sep 1987
CDR Jeffrey A. Lehman	24 Mar 1989
CDR Craig F. Weideman	14 Sep 1990

**Aircraft Assignment**

<i>Type of Aircraft</i>	<i>Date Type First Received</i>
A-7A	28 Jun 1967
A-7E	17 Sep 1969
F/A-18C	05 Dec 1989



*Two squadron F/A-18C Hornets firing air-to-ground rockets, 1990.*

### Major Overseas Deployments

Date of Departure	Date of Return	Air Wing	Carrier	Type of Aircraft	Area of Operation
04 Nov 1967	25 May 1968	CVW-2	CVA 61	A-7A	WestPac/Vietnam
26 Oct 1968	17 May 1969	CVW-2	CVA 61	A-7A	WestPac/Vietnam
10 Apr 1970	21 Dec 1970	CVW-9	CVA 66	A-7E	WestPac/Vietnam
01 Oct 1971	30 Jun 1972	CVW-9	CVA 64	A-7E	WestPac/Vietnam
05 Jan 1973	11 Oct 1973	CVW-9	CVA 64	A-7E	WestPac/Vietnam
21 Jun 1974	22 Dec 1974	CVW-9	CVA 64	A-7E	WestPac/IO
12 Apr 1977	21 Nov 1977	CVW-9	CV 64	A-7E	WestPac
26 Sep 1978	17 May 1979	CVW-9	CV 64	A-7E	WestPac/IO
26 Feb 1980	15 Oct 1980	CVW-9	CV 64*	A-7E	WestPac
20 Oct 1981	23 May 1982	CVW-9	CV 64*	A-7E	WestPac
13 Jan 1984	01 Aug 1984	CVW-2	CV 63	A-7E	WestPac/IO
24 Jul 1985	21 Dec 1985	CVW-9	CV 63	A-7E	WestPac/IO
03 Jan 1987	29 Jun 1987	CVW-9	CV 63	A-7E	World Cruise
02 Sep 1988	27 Feb 1989	CVW-9	CVN 68	A-7E	WestPac/IO
15 Jun 1989	09 Jul 1989	CVW-9	CVN 68	A-7E	NorPac

\* The squadron remained ashore at NAS Cubi Point as CVW-9's Beach Detachment during most of *Constellation's* deployment to WestPac. This shore based period for VA-147 was part of the Swing Wing Concept.

### Air Wing Assignments

Air Wing	Tail Code	Assignment Date
VA-122*		01 Feb 1967
CVW-2	NE	28 Jun 1967
CVW-9	NG	02 Jul 1969
CVW-2	NE	12 Nov 1982
CVW-9	NG	15 Sep 1984

\* The squadron was under the operational control of VA-122 during its period of training in the new A-7 Corsair II.

### Unit Awards Received

Unit Award	Inclusive Dates Covering Unit Award
MUC	03 Dec 1967 – 09 May 1968
	26 May 1970 – 08 Nov 1970
	12 Mar 1979 – 19 Apr 1979
	21 Jan 1987 – 17 May 1987
NUC	29 Nov 1968 – 10 May 1969
PUC	22 Oct 1971 – 13 Jun 1972
NAVE	01 Jan 1976 – 30 Jun 1977
AFEM	23 Jan 1968 – 22 Mar 1968



A formation of squadron F/A-18C Hornets fly over Kuwait City during Operation Southern Watch, 1993.

**Unit Awards Received**

<i>Unit Award</i>	<i>Inclusive Dates Covering Unit Award</i>	
NEM	20 Mar 1969	22 Mar 1969
	20 Apr 1969	27 Apr 1969
	24 Sep 1970	26 Sep 1970
	02 Nov 1988	05 Dec 1988
	12 Mar 1979	19 Apr 1979
	26 Apr 1980	04 Aug 1980
RVNGC	12 Aug 1980	19 Aug 1980
	02 Dec 1967	
	09 Jan 1968	
	15 Jan 1968	16 Jan 1968
	20 Jan 1968	24 Jan 1968
	26 Jan 1968	
	19 Mar 1968	25 Mar 1968
	29 Mar 1968	06 Apr 1968
	08 Apr 1968	10 Apr 1968
	21 Apr 1968	
	23 Apr 1968	24 Apr 1968
	29 Apr 1968	02 May 1968
	07 Jan 1969	30 Jan 1969
	15 Feb 1969	16 Mar 1969
	04 Apr 1969	14 Apr 1969
30 Mar 1972	01 Jun 1972	
VNSM	03 Dec 1967	29 Dec 1967

**Unit Awards Received**

<i>Unit Award</i>	<i>Inclusive Dates Covering Unit Award</i>	
	06 Jan 1968	28 Jan 1968
	18 Mar 1968	12 Apr 1968
	21 Apr 1968	09 May 1968
	07 Jan 1969	30 Jan 1969
	15 Feb 1969	16 Mar 1969
	04 Apr 1969	17 Apr 1969
	17 May 1970	
	19 May 1970	
	24 May 1970	16 Jun 1970
	28 Jun 1970	13 Jul 1970
	20 Jul 1970	04 Aug 1970
	24 Aug 1970	18 Sep 1970
	13 Oct 1970	09 Nov 1970
	02 Nov 1971	22 Nov 1971
	29 Nov 1971	31 Dec 1971
	09 Jan 1972	03 Feb 1972
	09 Feb 1972	02 Mar 1972
	13 Mar 1972	23 Mar 1972
	07 Apr 1972	18 May 1972
	24 May 1972	25 May 1972
	31 May 1972	13 Jun 1972
	25 Feb 1973	14 Mar 1973
	19 Mar 1973	28 Mar 1973



*A squadron F/A-18C Hornet being refueled by an Air Force KC-135H Stratotanker with a couple of F-14 Tomcats in the background, 1993.*

## VFA-151

### Lineage

Established as Fighter Squadron TWENTY THREE (VF-23) on 6 August 1948.

Redesignated Fighter Squadron ONE HUNDRED FIFTY ONE (VF-151) on 23 February 1959.

Redesignated Strike Fighter Squadron ONE HUNDRED FIFTY ONE (VFA-151) on 1 June 1986. The first squadron to be assigned the VFA-151 designation.



*The squadron's first insignia was the knight and shield design.*



*The squadron's second insignia, the skull and electron rings design, was approved by CNO in May 1955.*



*The squadron continued to use the skull and electron rings design following its redesignation to VFA.*

### Squadron Insignia and Nickname

The squadron's first insignia was approved by CNO on 9 August 1949. Colors for the knight and shield insignia were: large white shield outlined in black; blue helmet outlined in black with red gems; fuchsia cloak; purple outer garment with a green band around the waist and over the shoulder, silver chain mail; brown boots and straps; blue small shield outlined in black, inside the shield was an outer circle of white and a center of green; red lightning bolt; gold sword outlined in black with red gems.

A new insignia was approved by CNO on 26 May 1955. Colors for the skull insignia are: a black background outlined in yellow; white skull with black teeth and markings; red and black eyes; blue electron rings; gray sword with a red flame at the tip; white scroll with black lettering. The squadron continued to use this insignia following its redesignation to VF-151 and VFA-151.

Nickname: The Flashers, 1949–1959.

Vigilantes, 1959–present.

### Chronology of Significant Events

**15 Sep 1950:** The squadron flew combat missions in support of the amphibious landings at Inchon, Korea.

**Aug 1952:** Squadron aircraft participated in joint operations with the U.S. Air Force, striking targets in Pyongyang and the surrounding area.

**Mar 1954:** The squadron was deployed to the western Pacific aboard *Essex* (CVA 9) when the carrier was ordered to operate off the coast of Vietnam during the Viet Minh's assault against the French at Dien Bien Phu.



*A squadron F2H-3 Banshee prepares to launch from Essex (CVA 9), 1954 (Courtesy Robert Lawson Collection).*

**Aug–Sep 1958:** The squadron flew sorties in the Taiwan Straits after the Chinese Communists bombarded Quemoy Island.

**Jan 1961:** *Coral Sea* (CVA 43), with VF-151 embarked, operated in the South China Sea after Pathet Lao forces captured strategic positions in Laos.

**Mar 1965:** The squadron participated in Rolling Thunder operations, the systematic bombing of military targets in North Vietnam.

**24 Oct 1967:** The squadron's commanding officer, Commander C. R. Gillespie and his RIO Lieutenant (jg) R. C. Clark, were shot down by a surface-to-air missile while on a mission over North Vietnam. Commander Gillespie became a POW and was released on 14 March 1973, his RIO died in captivity.

**Mar 1968:** *Coral Sea*, with VF-151 embarked, operated on station off the coast of Korea following the capture of *Pueblo* (AGER 2) in January by North Korea.

**May–Oct 1972:** The squadron participated in Linebacker I operations, heavy air strikes against targets in North Vietnam to interdict the flow of supplies and to reduce North Vietnam's ability to continue the war effort in South Vietnam.

**Apr–May 1975:** Squadron aircraft participated in

Operation Frequent Wind, the evacuation of American personnel from Saigon, South Vietnam, as the country fell to the communists.

**Aug–Sep 1976:** Embarked in *Midway* (CV 41), the squadron conducted flight operations near the Korean Peninsula following the murder of U.S. military personnel in the Korean DMZ by North Koreans.

**Apr–May 1979:** *Midway*, with VF-151 embarked, deployed to the Gulf of Aden to relieve *Constellation* (CV 64) and maintain a U.S. carrier presence following the outbreak of fighting between North and South Yemen and the fall of the Shah of Iran.

**Nov 1979–Feb 1980:** Following the Iranian seizure of the American Embassy in Teheran and the taking of American hostages on 4 November, *Midway*, with VF-151 embarked, proceeded to the Gulf of Oman and remained on station until relieved in early February 1980.

**May–Jun 1980:** *Midway*, with VF-151 embarked, operated off the coast of Korea due to the civil unrest in South Korea and the massacre of several hundred people in the town of Kwangju.

**Dec 1981:** Following tensions in Korea, the squadron operated from *Midway* off the coast of Korea until the tensions subsided.

**Apr–Nov 1986:** VF-151 temporarily relocated to NAS Lemoore for transition training in the F/A-18 Hornet. The squadron's new Hornets were flown to Japan between 18–21 November. VF-151 was one of only two F-4 fighter squadrons to transition to the F/A-18 and be redesignated a strike fighter squadron.

**Sep 1988:** During the Summer Olympics in Seoul, South Korea, the squadron was embarked on *Midway* and operating in the Sea of Japan to demonstrate U.S. support for a peaceful olympics.

**Dec 1989:** *Midway*, with VFA-151 embarked, maintained station off the coast of the Philippines during an attempted coup in that country.

**Nov 1990–Jan 1991:** The squadron flew missions in support of Operation Desert Shield, the build up of American and Allied forces to counter a threatened invasion of Saudi Arabia by Iraq and as part of an economic blockade of Iraq to force its withdrawal from Kuwait.



A squadron F4U-5 Corsair on the deck of *Wright* (CVL 49), November 1948 (Courtesy Robert Lawson Collection).

**Home Port Assignments**

<i>Location</i>	<i>Assignment Date</i>
NAAS Oceana	06 Aug 1948
NAS Alameda	Aug 1950
NAS Moffett Field	11 Nov 1950
NAS Miramar	10 Jul 1961
NS Yokosuka (NAF Atsugi & Misawa)	05 Oct 1973*

\* VF-151, along with CVW-5 and *Midway* (CVA 41), were part of a program to permanently assign a carrier and air wing to an overseas home port. *Midway's* new home port was Naval Station Yokosuka, Japan. The squadron would normally operate out of NAF Atsugi or Misawa when the carrier was in port NS Yokosuka. The assignment was effective 30 June 1973. However, the squadron did not arrive until 5 October 1973.



*A squadron F-4B Phantom II is refueled by an A-6 Intruder while another squadron aircraft flies escort, June 1966.*

**Commanding Officers**

	<i>Date Assumed Command</i>
LCDR Thomas J. Gallagher, Jr.	06 Aug 1948
LCDR C. E. Russell	Jul 1950
CDR R. C. Mueller	14 Mar 1951
LCDR Charles C. Aikins	01 Feb 1952
LCDR William J. Moran	Feb 1953
CDR William H. Neal III	Jul 1954
CDR Charles A. Knight	Aug 1956
CDR R. K. Awtrey	07 Oct 1958
CDR J. H. Stewart	21 Nov 1958
CDR M. S. Alexatos	05 Feb 1960
CDR Randell H. Prothro	23 Jun 1961
CDR Charles L. Brooks	21 Jul 1962
CDR E. P. Hermann	09 Jul 1963
CDR Joseph M. Schneiders	07 Jul 1964
CDR J. D. Ward	Jun 1965
CDR John J. Chambers	09 Apr 1966

**Commanding Officers—Continued**

	<i>Date Assumed Command</i>
CDR Charles R. Gillispie, Jr.	Mar 1967
CDR Bobbie D. Williard	24 Oct 1967
CDR Russell E. Davis	04 Nov 1968
CDR Fred B. Winton, Jr.	28 Nov 1969
CDR Glenn F. Keene	19 Nov 1970
CDR Charles G. Kother	17 Dec 1971
CDR John S. Disher	01 Dec 1972
CDR Denis T. Schwaad	30 Aug 1973
CDR Eugene D. Conner	06 Dec 1974
CDR James D. Curry	30 Apr 1976
CDR Jay H. Hall	01 Jul 1977
CDR Hugh D. Wisely	18 Oct 1978
CDR Gary M. Hughes	25 Sep 1979
CDR Richard S. Farrell	30 Dec 1980
CDR Charles C. Buchanan, Jr.	16 Apr 1982
CDR Charles L. Robinson	12 Oct 1983
CDR Russell M. Taylor II	30 Apr 1985
CDR Terrill S. Heath	09 May 1986
CDR Thomas A. Perkins III	22 Apr 1988
CDR James R. Goddard, Jr.	09 Sep 1989

**Aircraft Assignment**

<i>Type of Aircraft</i>	<i>Date Type First Received</i>
F4U-5	06 Aug 1948
F6F-5P	06 Aug 1948
F4U-4	Apr 1949
F9F-2	04 Jan 1951
F2H-3	Mar 1953
F4D-1	Dec 1956
F3H-2	13 Jan 1959
F-4B	14 Jan 1964
F-4N	Mar 1973
F-4J	Aug 1977
F-4S	08 Dec 1980
F/A-18A	15 Jul 1986



*A formation of squadron F9F-2 Panthers in flight during their combat deployment to Korea aboard Princeton (CV 37) between May to August 1951.*



*A squadron F-4S Phantom II, in a low-visibility paint scheme, dives dropping bombs, circa 1986.*

**Major Overseas Deployments**

<i>Date of Departure</i>	<i>Date of Return</i>	<i>Air Wing</i>	<i>Carrier</i>	<i>Type of Aircraft</i>	<i>Area of Operation</i>
03 May 1949	26 Sep 1949	CVG-2	CVB 43	F4U-4	Med
24 Aug 1950	11 Nov 1950	CVG-2	CV 21	F4U-4	WestPac/Korea
12 May 1951	29 Aug 1951	CVG-19*	CV 37*	F9F-2	WestPac/Korea
16 Jun 1952	06 Feb 1953	ATG-2	CVA 9	F9F-2	WestPac/Korea
01 Dec 1953	12 Jul 1954	ATG-2	CVA 9	F2H-3	WestPac
19 Mar 1956	13 Sep 1956	ATG-4	CVA 10	F2H-3	WestPac
15 Feb 1958	02 Oct 1958	CVG-15	CVA 19	F4D-1	WestPac
01 Aug 1959	18 Jan 1960	CVG-15	CVA 19	F3H-2	WestPac
19 Sep 1960	27 May 1961	CVG-15	CVA 43	F3H-2	WestPac
12 Dec 1961	17 Jul 1962	CVG-15	CVA 43	F3H-2	WestPac
03 Apr 1963	25 Nov 1963	CVG-15	CVA 43	F3H-2	WestPac
07 Dec 1964	01 Nov 1965	CVW-15	CVA 43	F-4B	WestPac/Vietnam
12 May 1966	03 Dec 1966	CVW-15	CVA 64	F-4B	WestPac/Vietnam
26 Jul 1967	06 Apr 1968	CVW-15	CVA 43	F-4B	WestPac/Vietnam
07 Sep 1968	18 Apr 1969	CVW-15	CVA 43	F-4B	WestPac/Vietnam
23 Sep 1969	01 Jul 1970	CVW-15	CVA 43	F-4B	WestPac/Vietnam
16 Apr 1971	06 Nov 1971	CVW-5	CVA 41	F-4B	WestPac/Vietnam



**Major Overseas Deployments—Continued**

<i>Date of Departure</i>	<i>Date of Return</i>	<i>Air Wing</i>	<i>Carrier</i>	<i>Type of Aircraft</i>	<i>Area of Operation</i>
10 Apr 1972	03 Mar 1973	CVW-5	CVA 41	F-4B	WestPac/Vietnam
11 Sep 1973	05 Oct 1973	CVW-5	CVA 41	F-4N	WestPac†
16 Nov 1973	22 Dec 1973	CVW-5	CVA 41	F-4N	WestPac
29 Jan 1974	06 Mar 1974	CVW-5	CVA 41	F-4N	WestPac
18 Oct 1974	20 Dec 1974	CVW-5	CVA 41	F-4N	WestPac
13 Jan 1975	18 Feb 1975	CVW-5	CVA 41	F-4N	WestPac
31 Mar 1975	29 May 1975	CVW-5	CVA 41	F-4N	WestPac
04 Oct 1975	19 Dec 1975	CVW-5	CV 41	F-4N	WestPac/IO
13 Mar 1976	26 Apr 1976	CVW-5	CV 41	F-4N	WestPac
19 May 1976	22 Jun 1976	CVW-5	CV 41	F-4N	WestPac
09 Jul 1976	04 Aug 1976	CVW-5	CV 41	F-4N	WestPac
01 Nov 1976	17 Dec 1976	CVW-5	CV 41	F-4N	WestPac
11 Jan 1977	01 Mar 1977	CVW-5	CV 41	F-4N	WestPac
19 Apr 1977	05 May 1977	CVW-5	CV 41	F-4N	WestPac
08 Aug 1977	02 Sep 1977	CVW-5	CV 41	F-4N/J	WestPac
27 Sep 1977	21 Dec 1977	CVW-5	CV 41	F-4J	WestPac/IO
11 Apr 1978	23 May 1978	CVW-5	CV 41	F-4J	WestPac
09 Nov 1978	23 Dec 1978	CVW-5	CV 41	F-4J	WestPac
11 Jan 1979	20 Feb 1979	CVW-5	CV 41	F-4J	WestPac
07 Apr 1979	18 Jun 1979	CVW-5	CV 41	F-4J	WestPac/IO
20 Aug 1979	14 Sep 1979	CVW-5	CV 41	F-4J	WestPac
30 Sep 1979	20 Feb 1980	CVW-5	CV 41	F-4J	WestPac/IO
14 Jul 1980	26 Nov 1980	CVW-5	CV 41	F-4J	WestPac/IO
23 Feb 1981	05 Jun 1981	CVW-5	CV 41	F-4S	WestPac/IO
26 Jun 1981	16 Jul 1981	CVW-5	CV 41	F-4S	WestPac
03 Sep 1981	06 Oct 1981	CVW-5	CV 41	F-4S	WestPac
26 Apr 1982	18 Jun 1982	CVW-5	CV 41	F-4S	WestPac
14 Sep 1982	11 Dec 1982	CVW-5	CV 41	F-4S	NorPac/WestPac/IO
02 Jun 1983	13 Aug 1983	CVW-5	CV 41	F-4S	WestPac
25 Oct 1983	11 Dec 1983	CVW-5	CV 41	F-4S	WestPac
28 Dec 1983	23 May 1984	CVW-5	CV 41	F-4S	WestPac/IO
15 Oct 1984	12 Dec 1984	CVW-5	CV 41	F-4S	WestPac
01 Feb 1985	28 Mar 1985	CVW-5	CV 41	F-4S	WestPac
10 Jun 1985	14 Oct 1985	CVW-5	CV 41	F-4S	WestPac/IO
15 Nov 1985	12 Dec 1985	CVW-5	CV 41	F-4S	WestPac
17 Jan 1986	30 Mar 1986	CVW-5	CV 41	F-4S	WestPac
09 Jan 1987	20 Mar 1987	CVW-5	CV 41	F/A-18A	WestPac
23 Apr 1987	13 Jul 1987	CVW-5	CV 41	F/A-18A	WestPac
15 Oct 1987	12 Apr 1988	CVW-5	CV 41	F/A-18A	WestPac/IO
18 Oct 1988	09 Nov 1988	CVW-5	CV 41	F/A-18A	WestPac
21 Jan 1989	24 Feb 1989	CVW-5	CV 41	F/A-18A	WestPac
27 Feb 1989	09 Apr 1989	CVW-5	CV 41	F/A-18A	WestPac
31 May 1989	25 Jul 1989	CVW-5	CV 41	F/A-18A	WestPac
15 Aug 1989	11 Dec 1989	CVW-5	CV 41	F/A-18A	WestPac/IO
20 Feb 1990	06 Apr 1990	CVW-5	CV 41	F/A-18A	WestPac
02 Oct 1990	17 Apr 1991	CVW-5	CV 41	F/A-18A	WestPac/IO/ Persian Gulf

\* Squadron personnel, except 20 pilots and 13 enlisted men who were flown to Japan, embarked USNS *General Weigel* (TAP 119) for transportation from the U.S. to *Princeton* (CV 37), operating in Korea. The squadron embarked *Princeton* on 30 May 1951 and, along with other squadrons, replaced the original Air Group 19 squadrons that had deployed to Korea with the carrier. The primary squadrons in CVG-19 when it deployed to Korea in November 1950 included VF-191, VF-192, VF-193 and VA-195. These squadrons were replaced in May 1951 by VF-23, VF-821, VF-871 and VA-55.

† VF-151, CVW-5 and *Midway* arrived at their new home port, Naval Station Yokosuka, Japan. With the squadron permanently forward deployed all future deployments for the squadron will cover only those operations outside the home waters of Japan.



*A squadron F3H-2 Demon at NAS Miramar, California (Courtesy Duane Kasulka Collection).*



*Two squadron F4D-1 Skyraiders in flight during their deployment aboard Hancock (CVA 19) to WestPac in 1958.*

**Air Wing Assignments**

<i>Air Wing</i>	<i>Tail Code</i>	<i>Assignment Date</i>
CVBG-1/CVG-2*	M	06 Aug 1948
COMFAIRALAMEDA		03 Dec 1950
CVG-19	B	25 May 1951
CVG-2	M	29 Aug 1951
ATG-2	†	23 May 1952
ATG-4	Z‡	30 Mar 1955
CVG-15/CVW-15§	NL	29 Oct 1957

**Air Wing Assignments—Continued**

<i>Air Wing</i>	<i>Tail Code</i>	<i>Assignment Date</i>
CVW-16	AH	01 Sep 1970
CVW-5	NF	16 Feb 1971

\* CVBG-1 was redesignated CVG-2 on 1 September 1948.

† ATG-2 was not assigned a tail code until July 1956.

‡ The tail code Z was assigned to ATG-4 on 24 July 1956.

§ CVG-15 was redesignated CVW-15 when Carrier Air Groups (CVG) were redesignated Carrier Air Wings (CVW) on 20 December 1963.



*A squadron F/A-18A Hornet lands aboard Midway (CV 41), 1987.*

### **Unit Awards Received**

<i>Unit Award</i>	<i>Inclusive Dates Covering Unit Award</i>	
NAVE	01 Jan 1982	30 Jun 1983
	01 Jul 1983	31 Dec 1984
KPUC	15 Sep 1950	26 Oct 1950
KSM	14 Sep 1950	26 Oct 1950
	30 May 1951	16 Aug 1951
AFEM	26 Jul 1952	25 Jan 1953
	26 Aug 1958	07 Sep 1958
	14 Sep 1959	17 Sep 1959
	25 Apr 1961	28 Apr 1961
	30 Apr 1961	01 May 1961
	04 May 1961	09 May 1961
	12 Jan 1962	19 Jan 1962
	24 Jan 1962	27 Jan 1962
	02 Feb 1965	05 Mar 1965
	16 Mar 1965	17 Apr 1965
	02 May 1965	28 May 1965
	23 Jun 1965	03 Jul 1965
	23 Jan 1968	22 Mar 1968
	10 Dec 1969	11 Dec 1969
17 Oct 1971	19 Oct 1971	
20 Apr 1975	30 Apr 1975	
HSM	29 Apr 1975	30 Apr 1975
NUC	07 Feb 1965	18 Oct 1965
	29 May 1966	24 Nov 1966
	13 Aug 1967	19 Feb 1968
	10 Oct 1968	31 Mar 1969

### **Unit Awards Received—Continued**

<i>Unit Award</i>	<i>Inclusive Dates Covering Unit Award</i>	
	29 Apr 1975	30 Apr 1975
	01 Jan 1978	30 Jun 1979
MUC	17 Jan 1991	07 Feb 1991
	27 Oct 1969	01 Jun 1970
	07 May 1971	28 Oct 1971
	13 Nov 1979	08 Feb 1980
	27 Jul 1982	01 May 1984
	07 Sep 1989	25 Oct 1989
PUC	30 Apr 1972	09 Feb 1973
NEM	15 Apr 1979	06 Jun 1979
	21 Nov 1979	07 Feb 1980
	19 Aug 1980	13 Nov 1980
	12 Mar 1981	19 May 1981
SASM	17 Jan 1991	28 Feb 1991
RVNGC	12 Oct 1965	
	21 Jun 1966	22 Jun 1966
	23 Nov 1967	
	02 Dec 1967	
	04 Dec 1967	
	20 Dec 1967	22 Dec 1967
	20 Jan 1968	
	23 Jan 1968	27 Jan 1968
	29 Jan 1968	19 Feb 1968
	15 Oct 1968	
17 Oct 1968	18 Oct 1968	
	21 Oct 1968	

**Unit Awards Received—Continued**

<i>Unit Award</i>	<i>Inclusive Dates Covering Unit Award</i>	
	25 Oct 1968	27 Oct 1968
	14 Nov 1968	16 Nov 1968
	23 Nov 1968	
	25 Nov 1968	
	28 Nov 1968	
	01 Dec 1968	02 Dec 1968
	04 Dec 1968	05 Dec 1968
	30 Dec 1968	
	01 Jan 1969	03 Jan 1969
	05 Jan 1969	
	07 Jan 1969	10 Jan 1969
	14 Jan 1969	19 Jan 1969
	22 Jan 1969	
	24 Jan 1969	
	26 Jan 1969	
	09 Feb 1969	20 Feb 1969
	22 Feb 1969	03 Mar 1969
	19 Mar 1969	31 Mar 1969
	30 Mar 1972	15 Jul 1972
VNSM	04 Jul 1965	24 Jul 1965
	11 Aug 1965	11 Sep 1965
	21 Sep 1965	15 Oct 1965
	14 Jun 1966	13 Jul 1966
	27 Jul 1966	31 Aug 1966
	08 Sep 1966	01 Oct 1966
	19 Oct 1966	09 Nov 1966
	26 Aug 1967	01 Oct 1967

**Unit Awards Received—Continued**

<i>Unit Award</i>	<i>Inclusive Dates Covering Unit Award</i>	
	12 Oct 1967	28 Oct 1967
	04 Nov 1967	05 Nov 1967
	11 Nov 1967	08 Dec 1967
	16 Dec 1967	07 Jan 1968
	15 Jan 1968	21 Feb 1968
	29 Dec 1968	30 Jan 1969
	08 Feb 1969	03 Mar 1969
	19 Mar 1969	30 Mar 1969
	26 Oct 1969	18 Nov 1969
	22 Dec 1969	19 Jan 1970
	17 Feb 1970	09 Mar 1970
	19 Mar 1970	11 Apr 1970
	28 Apr 1970	01 Jun 1970
	17 May 1971	09 Jun 1971
	29 Jun 1971	20 Jul 1971
	31 Jul 1971	17 Aug 1971
	26 Sep 1971	11 Oct 1971
	01 May 1972	01 Jun 1972
	11 Jun 1972	07 Jul 1972
	16 Jul 1972	13 Aug 1972
	23 Aug 1972	10 Sep 1972
	19 Sep 1972	12 Oct 1972
	23 Oct 1972	23 Nov 1972
	03 Dec 1972	22 Dec 1972
	31 Dec 1972	
	04 Jan 1973	24 Jan 1973
	03 Feb 1973	09 Feb 1973
SASM	02 Nov 1990	14 Mar 1991



*A squadron F/A-18A Hornet flies over Mt. Fuji, Japan.*

## VFA-161

### Lineage

Established as Fighter Squadron ONE HUNDRED SIXTY ONE (VF-161) on 1 September 1960.

Redesignated Strike Fighter Squadron ONE HUNDRED SIXTY ONE (VFA-161) on 1 June 1986.

Disestablished on 1 April 1988. The first squadron to be assigned the VFA-161 designation.



*The squadron's first insignia was approved for use by CNO in 1962.*

was adopted at a later date, placing the design inside a red circular background with white scrolls outlined in red and red lettering on the scrolls.

A new squadron insignia was approved by CNO on 19 January 1982. Colors for the torii gate insignia were: a white background with a black and red torii gate; red lightning bolt outlined in white and black; black scrolls with red and white lettering.

Nickname: Chargers, 1960–1988.

### Squadron Insignia and Nickname

The squadron's first insignia was approved by CNO on 14 June 1962. Colors for the shield insignia were: a black shield with a white diagonal stripe; white trident and compass rose; and red stylized symbols on the diagonal stripe. A modification to the insignia



*A new insignia design was adopted by the squadron in 1982; however, the squadron still maintained its old Chargers nickname.*

### Chronology of Significant Events

**Nov 1963:** Embarked on *Oriskany* (CVA 34), the squadron operated in the South China Sea during a crisis in South Vietnam and the coup that overthrew President Diem.

**13 Jun 1966:** Following a strike by CVW-15 aircraft against a railroad and highway bridge in North Vietnam, four Phantoms from VF-161 engaged six North Vietnamese MiG-17s that were pursuing the retiring strike aircraft. Lieutenant William M. McGuigan and his RIO, Lieutenant (jg) Robert M. Fowler, shot down one of the MiG-17s with a Sidewinder missile.

The other MiGs were driven off and all CVW-15 aircraft returned from the mission.

**Mar 1968:** *Coral Sea* (CVA 43), with VF-161 embarked, operated on station off the coast of Korea following the capture of *Pueblo* (AGER 2) in January by North Korea.

**May–Oct 1972:** The squadron participated in Linebacker I operations, heavy air strikes against targets in North Vietnam to interdict the flow of supplies and to reduce North Vietnam's ability to continue the war effort in South Vietnam.

**18 May 1972:** While flying MiG Combat Air Patrol near Kep Airfield in North Vietnam, two of the squadron's F-4B Phantoms engaged two MiG-19s. Lieutenant Henry A. Bartholomay and his RIO, Lieutenant Oran R. Brown, shot down the first MiG with a Sidewinder. A few seconds later, their wingman, Lieutenant Patrick E. Arwood and his RIO, Lieutenant James M. Bell, shot down the other MiG with a Sidewinder.

**23 May 1972:** Two of the squadron's aircraft, while flying MiG Combat Air Patrol for a strike in the Haiphong area, were vectored toward Kep Airfield and sighted 4 MiG-17s and 2 MiG-19s. VF-161's aircraft proceeded to engage the MiGs even though they were outnumbered 3 to 1. In the ensuing battle Lieutenant Commander Ronald E. McKeown and his RIO, Lieutenant John C. Enschede, shot down a MiG-17 and a MiG-19 with Sidewinders. The other 4 MiGs escaped and both of VF-161's aircraft returned to *Midway* (CVA 41). Both men were awarded the Navy Cross for their actions.

**12 Jan 1973:** Lieutenant Victor T. Kovaleski and his RIO, Lieutenant James A. Wise, shot down a MiG-17 over the Gulf of Tonkin. This was the last MiG aircraft to be shot down during the Vietnam Conflict.

**Apr–May 1975:** Squadron aircraft participated in Operation Frequent Wind, the evacuation of American personnel from Saigon, South Vietnam, as the country fell to the communists.

**Aug–Sep 1976:** Embarked in *Midway* (CV 41), the squadron conducted flight operations near the Korean Peninsula following the murder of U.S. military personnel in the Korean DMZ by North Koreans.

**Apr–May 1979:** *Midway*, with VF-161 embarked, deployed to the Gulf of Aden to relieve *Constellation* (CV 64) and maintain a U.S. carrier presence following the outbreak of fighting between North and South Yemen and the fall of the Shah of Iran.

**Nov 1979–Feb 1980:** Following the Iranian seizure of the American Embassy in Teheran and the taking of American hostages on 4 November, *Midway*, with VF-161 embarked, proceeded to the Gulf of Oman and remained on station until relieved in early February 1980.

**May–Jun 1980:** *Midway*, with VF-161 embarked, operated off the coast of Korea due to the civil unrest

in South Korea and the massacre of several hundred people in the town of Kwangju.

**Dec 1981:** Due to tensions in Korea the squadron operated from *Midway* off the coast of Korea until the tensions subsided.

**May-Oct 1986:** The squadron relocated to NAS Lemoore for transition training in the F/A-18 Hornet and redesignation to a Strike Fighter Squadron. VF-161 was one of only two F-4 fighter squadrons to be assigned the VFA designation.

**Oct 1986-Jun 1987:** Following the transfer of the squadron from CVW-5, and awaiting transfer to a newly established air wing, the squadron was in an inactive status at NAS Lemoore.



*A squadron F3H-2 (F-3) Demon is refueled by an A-4 Skyhawk.*



*The squadron's last F3H-2 (F-3) Demon is piped over the side during a ceremony at NAS Miramar, California, September 1964.*

### Home Port Assignments

<i>Location</i>	<i>Assignment Date</i>
NAS Cecil Field	01 Sep 1960
NAS Miramar	19 Sep 1961
NS Yokosuka (NAF Atsugi & Misawa)	05 Oct 1973*
NAS Lemoore	Oct 1986†

\* VF-161, along with CVW-5 and *Midway* (CVA 41), were part of a program to permanently assign a carrier and air wing to an overseas home port. *Midway's* new home port was NS Yokosuka, Japan and the squadron would normally operate out of NAF Atsugi or Misawa when the carrier was in NS Yokosuka. The assignment was effective 30 June 1973. However, the squadron and carrier did not arrive until 5 Oct 1973.

† When the decision was made to remove VFA-161 from CVW-5 and not send it back to Japan following its transition training in the F/A-18, it is believed the squadron's home port was changed to NAS Lemoore at that time.

### Commanding Officers

	<i>Date Assumed Command</i>
CDR W. C. Hartung	01 Sep 1960
CDR Albert R. Groves	28 Dec 1961
CDR Joseph F. Bolger	28 Dec 1962
CDR Walter T. Broughton II	12 Jul 1963
CDR Wayne J. Welty	10 Jul 1964
CDR L. N. Hoover	28 Sep 1965
CDR Richard J. Schulte	16 Dec 1966
CDR Roger E. Sheets	04 Feb 1968
CDR Sherman W. Turner	09 May 1969
CDR Thomas J. Cassidy, Jr.	17 Apr 1970
CDR John A. Dickson	26 Mar 1971

**Commanding Officers—Continued**

	<i>Date Assumed Command</i>
CDR Earl W. Connell	10 Mar 1972
CDR C. C. Hoffner	23 Mar 1973
CDR T. R. Swartz	08 Mar 1974
CDR J. W. Lovell	25 Jun 1975
CDR Thomas C. Koehler	23 Sep 1976
CDR John M. Nash	30 Dec 1977
CDR Andrew L. Burgess	27 Mar 1979
CDR Joseph L. K. Corcoran	05 Jun 1980
CDR Newell Tarrant	22 Oct 1981
CDR R. C. Williamson	22 Dec 1982
CDR John P. Patton	22 Jun 1984

**Commanding Officers—Continued**

	<i>Date Assumed Command</i>
CDR John F. Williams	03 Apr 1986
CDR A. R. Gorthy, Jr.	1987

**Aircraft Assignment**

<i>Type of Aircraft</i>	<i>Date Type First Received</i>
F3H-2/F-3B*	12 Oct 1960
F-4B	05 Aug 1964
F-4N	1973
F-4J	1977
F-4S	06 Feb 1981
F/A-18A	09 Jul 1986

\* The F3H-2 designation was changed to F-3B in 1962.



*A formation of squadron F-4B Phantom IIs, 1971.*

### *Major Overseas Deployments*

<i>Date of Departure</i>	<i>Date of Return</i>	<i>Air Wing</i>	<i>Carrier</i>	<i>Type of Aircraft</i>	<i>Area of Operation</i>
07 Jun 1962	17 Dec 1962	CVG-16	CVA 34	F3H-2	WestPac
01 Aug 1963	10 Mar 1964	CVW-16	CVA 34	F-3B	WestPac
12 May 1966	03 Dec 1966	CVW-15	CVA 64	F-4B	WestPac/Vietnam
26 Jul 1967	06 Apr 1968	CVW-15	CVA 43	F-4B	WestPac/Vietnam
07 Sep 1968	18 Apr 1969	CVW-15	CVA 43	F-4B	WestPac/Vietnam
23 Sep 1969	01 Jul 1970	CVW-15	CVA 43	F-4B	WestPac/Vietnam
16 Apr 1971	06 Nov 1971	CVW-5	CVA 41	F-4B	WestPac/Vietnam
10 Apr 1972	03 Mar 1973	CVW-5	CVA 41	F-4B	WestPac/Vietnam
11 Sep 1973	05 Oct 1973	CVW-5	CVA 41	F-4N	WestPac*
16 Nov 1973	22 Dec 1973	CVW-5	CVA 41	F-4N	WestPac
29 Jan 1974	06 Mar 1974	CVW-5	CVA 41	F-4N	WestPac
18 Oct 1974	20 Dec 1974	CVW-5	CVA 41	F-4N	WestPac
13 Jan 1975	18 Feb 1975	CVW-5	CVA 41	F-4N	WestPac
31 Mar 1975	29 May 1975	CVW-5	CVA 41	F-4N	WestPac
04 Oct 1975	19 Dec 1975	CVW-5	CV 41	F-4N	WestPac/IO
13 Mar 1976	26 Apr 1976	CVW-5	CV 41	F-4N	WestPac
19 May 1976	22 Jun 1976	CVW-5	CV 41	F-4N	WestPac
09 Jul 1976	04 Aug 1976	CVW-5	CV 41	F-4N	WestPac
01 Nov 1976	17 Dec 1976	CVW-5	CV 41	F-4N	WestPac
11 Jan 1977	01 Mar 1977	CVW-5	CV 41	F-4N	WestPac
19 Apr 1977	05 May 1977	CVW-5	CV 41	F-4N	WestPac
08 Aug 1977	02 Sep 1977	CVW-5	CV 41	F-4N/J	WestPac
27 Sep 1977	21 Dec 1977	CVW-5	CV 41	F-4J	WestPac/IO
11 Apr 1978	23 May 1978	CVW-5	CV 41	F-4J	WestPac
09 Nov 1978	23 Dec 1978	CVW-5	CV 41	F-4J	WestPac
11 Jan 1979	20 Feb 1979	CVW-5	CV 41	F-4J	WestPac
07 Apr 1979	18 Jun 1979	CVW-5	CV 41	F-4J	WestPac/IO
20 Aug 1979	14 Sep 1979	CVW-5	CV 41	F-4J	WestPac
30 Sep 1979	20 Feb 1980	CVW-5	CV 41	F-4J	WestPac/IO
14 Jul 1980	26 Nov 1980	CVW-5	CV 41	F-4J	WestPac/IO
23 Feb 1981	05 Jun 1981	CVW-5	CV 41	F-4S	WestPac/IO
26 Jun 1981	16 Jul 1981	CVW-5	CV 41	F-4S	WestPac
03 Sep 1981	06 Oct 1981	CVW-5	CV 41	F-4S	WestPac
26 Apr 1982	18 Jun 1982	CVW-5	CV 41	F-4S	WestPac
14 Sep 1982	11 Dec 1982	CVW-5	CV 41	F-4S	NorPac/WestPac/IO
02 Jun 1983	13 Aug 1983	CVW-5	CV 41	F-4S	WestPac
25 Oct 1983	11 Dec 1983	CVW-5	CV 41	F-4S	WestPac
28 Dec 1983	23 May 1984	CVW-5	CV 41	F-4S	WestPac/IO
15 Oct 1984	12 Dec 1984	CVW-5	CV 41	F-4S	WestPac
01 Feb 1985	28 Mar 1985	CVW-5	CV 41	F-4S	WestPac
10 Jun 1985	14 Oct 1985	CVW-5	CV 41	F-4S	WestPac/IO
15 Nov 1985	12 Dec 1985	CVW-5	CV 41	F-4S	WestPac
17 Jan 1986	30 Mar 1986	CVW-5	CV 41	F-4S	WestPac

\* VF-161, CVW-5 and *Midway* arrived at their new home port, NS Yokosuka, Japan. With the squadron permanently forward deployed, all future deployments for the squadron will cover only those operations outside the home waters of Japan.





*A squadron F-4S Phantom II, in a low-visibility paint scheme, comes in for a landing on Midway (CV 41), 1985.*

### **Air Wing Assignments**

<i>Air Wing</i>	<i>Tail Code</i>	<i>Assignment Date</i>
CVG-16/CVW-16*	AH	01 Sep 1960
RCVW-12†		Oct 1964
CVW-15	NL	15 Dec 1965
CVW-16	AH	01 Sep 1970
CVW-5	NF	16 Feb 1971
COMLATWINGPAC		Oct 1986
CVW-10	NM	15 Jun 1987

\* CVG-16 was redesignated CVW-16 when Carrier Air Groups (CVG) were redesignated Carrier Air Wings (CVW) on 20 December 1963.

† The squadron was assigned to RCVW-12 during transitional training in the F-4 Phantom II.

### **Unit Awards Received**

<i>Unit Award</i>	<i>Inclusive Dates Covering Unit Award</i>	
PUC	30 Apr 1972	09 Feb 1973
NAVE	01 Jul 1977	31 Dec 1978
	01 Jan 1979	30 Jun 1980
AFEM	05 Sep 1963	13 Sep 1963
	03 Nov 1963	08 Nov 1963

### **Awards Received—Continued**

<i>Unit Award</i>	<i>Inclusive Dates Covering Unit Award</i>	
	23 Jan 1968	22 Mar 1968
	10 Dec 1969	11 Dec 1969
	17 Oct 1971	19 Oct 1971
	20 Apr 1975	30 Apr 1975
HSM	29 Apr 1975	30 Apr 1975
NUC	29 May 1966	24 Nov 1966
	13 Aug 1967	19 Feb 1968
	10 Oct 1968	31 Mar 1969
	29 Apr 1975	30 Apr 1975
	01 Jan 1978	30 Jun 1979
MUC	27 Oct 1969	01 Jun 1970
	07 May 1971	28 Oct 1971
	13 Nov 1979	08 Feb 1980
	27 Jul 1982	01 May 1984
NEM	15 Apr 1979	06 Jun 1979
	21 Nov 1979	07 Feb 1980
	19 Aug 1980	13 Nov 1980
	12 Mar 1981	19 May 1981
RVNGC	21 Jun 1966	22 Jun 1966
	23 Nov 1967	
	02 Dec 1967	

**Awards Received—Continued**

<i>Unit Award</i>	<i>Inclusive Dates Covering Unit Award</i>	
	04 Dec 1967	
	20 Dec 1967	22 Dec 1967
	20 Jan 1968	
	23 Jan 1968	27 Jan 1968
	29 Jan 1968	19 Feb 1968
	15 Oct 1968	
	17 Oct 1968	18 Oct 1968
	21 Oct 1968	
	25 Oct 1968	27 Oct 1968
	14 Nov 1968	16 Nov 1968
	23 Nov 1968	
	25 Nov 1968	
	28 Nov 1968	
	01 Dec 1968	02 Dec 1968
	04 Dec 1968	05 Dec 1968
	30 Dec 1968	
	01 Jan 1969	03 Jan 1969
	14 Jan 1969	19 Jan 1969
	22 Jan 1969	
	24 Jan 1969	
	26 Jan 1969	
	09 Feb 1969	20 Feb 1969
	22 Feb 1969	03 Mar 1969
	19 Mar 1969	31 Mar 1969
	30 Mar 1972	15 Jul 1972
VNSM	14 Jun 1966	13 Jul 1966
	27 Jul 1966	31 Aug 1966
	08 Sep 1966	01 Oct 1966

**Awards Received—Continued**

<i>Unit Award</i>	<i>Inclusive Dates Covering Unit Award</i>	
	19 Oct 1966	09 Nov 1966
	26 Aug 1967	01 Oct 1967
	12 Oct 1967	28 Oct 1967
	04 Nov 1967	05 Nov 1967
	11 Nov 1967	08 Dec 1967
	16 Dec 1967	07 Jan 1968
	15 Jan 1968	21 Feb 1968
	29 Dec 1968	30 Jan 1969
	08 Feb 1969	03 Mar 1969
	19 Mar 1969	30 Mar 1969
	26 Oct 1969	18 Nov 1969
	22 Dec 1969	19 Jan 1970
	17 Feb 1970	09 Mar 1970
	19 Mar 1970	11 Apr 1970
	28 Apr 1970	01 Jun 1970
	17 May 1971	09 Jun 1971
	29 Jun 1971	20 Jul 1971
	31 Jul 1971	17 Aug 1971
	26 Sep 1971	11 Oct 1971
	01 May 1972	01 Jun 1972
	11 Jun 1972	07 Jul 1972
	16 Jul 1972	13 Aug 1972
	23 Aug 1972	10 Sep 1972
	19 Sep 1972	12 Oct 1972
	23 Oct 1972	23 Nov 1972
	03 Dec 1972	22 Dec 1972
	31 Dec 1972	
	04 Jan 1973	24 Jan 1973
	03 Feb 1973	09 Feb 1973



*A squadron F/A-18A Hornet prepares to launch from Enterprise (CVN 65), July 1987.*

## VFA-192

### Lineage

Established as Fighter Squadron ONE HUNDRED FIFTY THREE (VF-153) on 26 March 1945.

Redesignated Fighter Squadron FIFTEEN A (VF-15A) on 15 November 1946.

Redesignated Fighter Squadron ONE HUNDRED FIFTY ONE (VF-151) on 15 July 1948.

Redesignated Fighter Squadron ONE HUNDRED NINETY TWO (VF-192) on 15 February 1950.

Redesignated Attack Squadron ONE HUNDRED NINETY TWO (VA-192) on 15 March 1956.

Redesignated Strike Fighter Squadron ONE HUNDRED NINETY TWO (VFA-192) on 10 January 1986. The first squadron to be assigned the VA-192 and VFA-192 designations.

### Squadron Insignia and Nickname

The squadron's first insignia was approved by CNO on 11 October 1945. Colors for the kangaroo insignia were:



*The fighting kangaroo design was the squadron's first insignia.*

a white cloud with pale blue shading; reddish brown kangaroo with a white chest and belly, ears were lined in reddish tan with blue markings, white jowls with blue shading, black nose, blue eye with a black pupil, white teeth outlined in black, and a red mouth; crimson boxing gloves; red, orange and white rocket tips; blue rocket body

with pale tan markings, and royal blue tail fins; yellow bombs with a forest green tail; tan machine gun bullets with red tips and held together by a black belt; blue perspiration marks and black lettering.



*The helmet and shield design with the Fighting Fifteen A designation in the scroll was the squadron's second insignia.*



*When the squadron was redesignated VF-151, this modified helmet and shield design was adopted by the squadron.*



*In 1950, the squadron adopted the dragon and carrier insignia following its redesignation from VF-151 to VF-192.*

When the squadron was redesignated VF-151, the helmet and shield insignia was modified and the Latin inscription *In Omnia Paratus* was added to the scroll inside the design. The Latin phrase means ever ready or a state of readiness. The squadron's designation Fighting One Fifty One was added in a lower scroll. Colors for the design remained the same as the previous design.

A new squadron insignia was approved by CNO on 8 August 1950. Colors for the dragon and carrier insignia were:



*In 1956, following another redesignation, the squadron adopted a newly designed dragon insignia.*

low dragon with black markings, red tongue and white teeth, white eye with a black and red pupil; black and white nuclear symbol and a white cloud with black markings with a red rising center; blue scroll outlined in black with black lettering. This design was continued following the designation change to VFA.

Nicknames: Golden Dragons, 1956-present.

Following the squadron's redesignation to VF-15A, a new insignia was approved by CNO on 24 November 1947. Colors for the helmet and shield insignia were: a white background outlined in black; gold shield outlined in black with a black diagonal stripe; black helmet with gold markings; black and gold scroll with white lettering.

sky blue background and dark blue water with white markings; gray carrier outlined in black; silver dragon with a red tongue and tail.

When the squadron was redesignated VA-192, a new insignia was approved by CNO on 21 June 1956. Colors for the new dragon design are: a blue background outlined in black; yellow



*A scroll with the designation VA-192 was added to the dragon insignia. This design remained the same following the squadron's redesignation to VFA; and the only change was in the scroll.*

### Chronology of Significant Events

**27 Jan–24 Feb 1949:** Half of the squadron's personnel and aircraft deployed aboard *Boxer* (CV 21) for a Pacific Fleet Minor Cold Weather Exercise near Kodiak, Alaska.



A squadron F4U-4 prepares to launch from Princeton (CV 37), circa 1950 or 1951 (Courtesy Robert Lawson Collection).

**5 Dec 1950:** The squadron flew its first combat missions, providing close air support for U.S. Marines near Chosen Reservoir in North Korea.

**1 May 1951:** The squadron participated in a special strike against the Hwachon Reservoir Dam with VF-193 and VA-195. The purpose of the mission was to destroy the flood gates and raise the level of the river to form a natural barrier against the enemy's advance. While VA-195 was dropping torpedoes to destroy the flood gates of the dam, the squadron's F4U-4s were concentrating on flak and small arms suppression.

**23–24 Jun 1952:** The squadron, along with units from two other carrier air groups and the Fifth Air Force, conducted coordinated air strikes against North Korean hydroelectric plants. Squadron aircraft struck the Suiho hydroelectric plant on the Yalu River on 23 June. On 24 June their aircraft struck the Kyosen Number Three hydroelectric plant and the Fusen Number Two hydroelectric plant.

**Jul 1952:** Squadron aircraft participated in one of the major joint Navy, Air Force and Marine Corps air strikes of the war, hitting industrial targets in North Korea's capital city of Pyongyang during the month of July.

**20 and 26 Apr 1967:** On 20 April Lieutenant Commander Michael J. Estocin, a member of VA-192, lead a three-plane group on an antisurface-to-air missile mission over North Vietnam in advance of a coordinated strike by aircraft from *Ticonderoga* (CVA 14) and *Kitty Hawk* (CVA 63) against two important thermal power plants in Haiphong. After personally neutralizing three surface-to-air missile sites, his aircraft was damaged by an exploding missile. Without regard

for his personal safety he reentered the target area with his damaged aircraft, in the face of intense anti-aircraft fire, to attack another missile site to ensure the target area's missile sites were neutralized prior to strikes from the carriers' incoming aircraft. Commander Estocin departed the target area with only five minutes of fuel left. He was refueled enroute to the *Ticonderoga* and landed his damaged plane on the carrier. Upon landing, his plane burst into flames. He was able to secure the engine and escape the aircraft without assistance. On 26 April Commander Estocin led a two-plane group on a similar mission in preparation for a coordinate strike against an oil facility in Haiphong. During this mission his aircraft was again damaged by an exploding surface-to-air missile. He continued his attack against the missile site, launching his missiles from a burning aircraft. Following the attack he attempted to guide his burning aircraft to the safety of the sea. The aircraft was last seen going out of control as it entered a cloud layer over North Vietnam. Commander Estocin was listed as MIA on 26 April 1967 and on 10 November 1977 his MIA status was changed to presumed KIA. For his actions Commander Estocin was posthumously awarded the Medal of Honor.

**Mar 1968:** VA-192, along with other squadrons in CVW-19, conducted flight operations from *Ticonderoga* in the Sea of Japan. These operations, part of Operation Formation Star, were conducted as part of a continuing show of American forces in the area following the capture of *Pueblo* (AGER 2) by North Korea on 23 January 1968.

**Apr 1972:** Following the invasion by North Vietnam into South Vietnam the squadron participated in tactical air sorties against military and logistic targets in North Vietnam.

**May 1972:** Squadron aircraft participated in the mining of North Vietnamese harbors and Linebacker I operations, concentrated air strikes against targets in North Vietnam above the 20th parallel.

**23 Nov 1973:** VA-192 deployed with CVW-11 embarked on *Kitty Hawk* (CV 63) as part of the first CV concept air wing deployment on the west coast. This concept employed all aspects of carrier aviation warfare into one air wing deployed on a single deck.

**Jul–Aug 1983:** *Ranger* (CV 61), with VA-912 embarked, was ordered to operate off the coast of Nicaragua in response to an unstable situation in Central America and the possible invasion of Honduras by Nicaragua.

**Oct 1983–Jan 1984:** *Ranger*, with VA-192 embarked, was extended on station in the Arabian Sea due to the Iranian threat to block oil exports from the Persian Gulf.

**4–8 Jun 1985:** The squadron flew its A-7E Corsair IIs via Hawaii and Wake Island for deployment to MCAS Iwakuni, Japan.

**Jun-Dec 1985:** While deployed to MCAS Iwakuni as part of MAG-12 the squadron also conducted operations from NAF Kadena and NAS Cubi Point.

**Nov 1986:** The squadron flew its F/A-18 Hornets from NAS Lemoore, via Hawaii and Guam, to NAF Atsugi, Japan, for operations with CVW-5 and *Midway* (CV 41).

**Nov 1987-Feb 1988:** The squadron participated in Earnest Will Operations, the escorting of reflagged Kuwaiti tankers through the Persian Gulf.

**Sep 1988:** During the Summer Olympics in Seoul,

Korea, the squadron was embarked on *Midway* and operating in the Sea of Japan to demonstrate U.S. support for a peaceful Olympics.

**Dec 1989:** *Midway*, with VFA-192 embarked, maintained station off the coast of the Philippines during an attempted coup in that country.

**Nov 1990-Jan 1991:** The squadron flew missions in support of Operation Desert Shield, the build up of American and Allied forces to counter a threatened invasion of Saudi Arabia by Iraq and as part of an economic blockade of Iraq to force its withdrawal from Kuwait.



*A squadron F6F-5P Hellcat in flight, 1946 (Courtesy Robert Lawson Collection).*



*A squadron F8F-1 Bearcat on the deck of Tarawa (CV 40), 1948 (Courtesy Robert Lawson Collection).*

**Home Port Assignments**

<i>Location</i>	<i>Assignment Date</i>
NAS Atlantic City	26 Mar 1945
NAAS Oceana	01 Jun 1945
NAS Alameda	Aug 1946
NAS Moffett Field	16 Jul 1951
NAS Lemoore	01 Jan 1962
NS Yokosuka, Japan (NAF Atsugi & Misawa)	01 Jul 1986*

\* VFA-192 was assigned to CVW-5 on 1 July 1986 as part of a program that has a permanently assigned carrier and air wing at an overseas home port. The home port for CVW-5 and *Midway* (CV 41) was NS Yokosuka, Japan. The squadron did not arrive in Japan until November 1986.



*A squadron F9F-5 on the elevator of Oriskany (CVA 34) during a WestPac cruise in 1953–1954.*

**Commanding Officers**

	<i>Date Assumed Command</i>
LCDR Kenneth P. Hance	26 Mar 1945
LCDR Wilson G. Wright	26 Apr 1946
LCDR Richard E. Brown	22 Oct 1947

**Commanding Officers—Continued**

	<i>Date Assumed Command</i>
LCDR Frank C. Perry	08 Mar 1949
LCDR K. S. Van Meter	26 Jun 1950
CDR Elwin A. Parker	27 Jul 1951
LCDR John H. Dinneen	28 Nov 1952
LCDR Giro N. V. Whited	Apr 1954
CDR Frank E. Foltz	Oct 1955
LCDR William R. Flanagan	30 Sep 1957
LCDR Larry F. Baumgaertel	19 Sep 1958
CDR William E. Payne, Jr.	01 Jul 1959
CDR Harold F. Snowden	May 1960
CDR Benjamin W. Adams	Mar 1961
LCDR Mitchell M. Simmons	15 Feb 1962
CDR Keith T. Weaver	21 Feb 1963
CDR William H. Rogers	10 Dec 1963
CDR Eugene E. Tissot	Dec 1964
CDR Allen E. Hill	Dec 1965
CDR Ed D. McKellar	15 Dec 1966
CDR Lowell F. Eggert	Dec 1967
CDR Joseph K. Stanley	13 Dec 1968
CDR Robert E. Woodbury	19 Oct 1969
CDR David C. Parkhurst	05 Aug 1970
CDR Richard L. Kiehl	30 Apr 1971
CDR Robert C. Taylor, Jr.	08 May 1972
CDR Darrel D. Owens	May 1973
CDR David N. Rogers	16 Jul 1974
CDR Gordon R. Goldenstein	06 Oct 1975
CDR Joseph D. Cole	21 Jan 1977
CDR John L. McWhinney	24 Apr 1978
CDR Thomas B. Latendresse	27 Jun 1980
CDR John J. Zerr	12 Sep 1981
CDR Harry T. Rittenour	28 Jun 1982
CDR Gilman E. Rud	15 Jun 1983
CDR C. D. Englehardt	17 Aug 1984
CDR Robert G. Ferver	10 Jan 1986
CDR John F. Williams	09 Apr 1987
CDR John A. Pettitt	13 May 1988
CDR Michael D. Shutt	06 Sep 1989
CDR James B. Godwin III	01 Mar 1991



*Two squadron F9F-8 Cougars fly in formation with an aircraft from VFP-61 during their deployment aboard Yorktown (CVA 10) in 1957.*

### Aircraft Assignment

<i>Type of Aircraft</i>	<i>Date Type First Received</i>
F6F-3	Mar 1945
F6F-5	Apr 1945
F8F-1	Nov 1947
F8F-2	Jul 1949
F4U-4	Jul 1950
F9F-2*	14 Jul 1951
F9F-2	03 Dec 1952
F9F-5	Jan 1953
F9F-6	Jan 1956
F9F-8B	Jun 1956
F9F-8	Jul 1956
FJ-4B	10 Dec 1957
A4D-2	Jul 1959
A4D-2N/A-4C†	01 Jun 1960
A-4E	Jun 1966
A-4F	Jul 1967
A-7E	26 Feb 1970
F/A-18A	05 May 1986

\* On 9 October 1951 the squadron transferred all its F9F-2s to VF-191 and received F4U-4s in exchange.

† The A4D-2N designation was changed to A-4C in 1962.



*Squadron FJ-4B Furys fly over Mt. Fuji, Japan, during their deployment to WestPac aboard Bon Homme Richard (CVA 31), 1958–1959.*

### Major Overseas Deployments

<i>Date of Departure</i>	<i>Date of Return</i>	<i>Air Wing</i>	<i>Carrier</i>	<i>Type of Aircraft</i>	<i>Area of Operation</i>
31 Mar 1947	08 Oct 1947	CVAG-15	CV 36	F6F-5	WestPac
11 Jan 1950	13 Jun 1950	CVG-19	CV 21	F8F-2	WestPac
09 Nov 1950	09 Jun 1951	CVG-19	CV 37*	F4U-4	WestPac/Korea
21 Mar 1952	03 Nov 1952	CVG-19	CV 37	F4U-4	WestPac/Korea
14 Sep 1953	22 Apr 1954	CVG-19	CVA 34	F9F-5	WestPac
02 Mar 1955	21 Sep 1955	CVG-19	CVA 34	F9F-5	WestPac
09 Mar 1957	25 Aug 1957	CVG-19	CVA 10	F9F-8/8B	WestPac
01 Nov 1958	18 Jun 1959	CVG-19	CVA 31	FJ-4B	WestPac
21 Nov 1959	14 May 1960	CVG-19	CVA 31	A4D-2	WestPac
26 Apr 1961	13 Dec 1961	CVG-19	CVA 31	A4D-2N	WestPac
12 Jul 1962	11 Feb 1963	CVG-19	CVA 31	A-4C	WestPac
28 Jan 1964	21 Nov 1964	CVW-19	CVA 31	A-4C	WestPac/IO/Vietnam
21 Apr 1965	13 Jan 1966	CVW-19	CVA 31	A-4C	WestPac/Vietnam
15 Oct 1966	29 May 1967	CVW-19	CVA 14	A-4E	WestPac/Vietnam
28 Dec 1967	17 Aug 1968	CVW-19	CVA 14	A-4F	WestPac/Vietnam
14 Apr 1969	17 Nov 1969	CVW-19	CVA 34	A-4F	WestPac/Vietnam
06 Nov 1970	17 Jul 1971	CVW-11	CVA 63	A-7E	WestPac/Vietnam
17 Feb 1972	28 Nov 1972	CVW-11	CVA 63	A-7E	WestPac/Vietnam
23 Nov 1973	09 Jul 1974	CVW-11	CV 63	A-7E	WestPac/IO
21 May 1975	15 Dec 1975	CVW-11	CV 63	A-7E	WestPac
25 Oct 1977	22 Sep 1978	CVW-11	CV 63	A-7E	WestPac
13 Mar 1979	22 Sep 1979	CVW-11	CV 66	A-7E	Med
14 Apr 1981	12 Nov 1981	CVW-11	CV 66	A-7E	Med/IO
15 Jul 1983	29 Feb 1984	CVW-9	CV 61	A-7E	Central America/ WestPac/IO
04 Jun 1985	14 Dec 1985	MAG-12	†	A-7E	WestPac
09 Jan 1987	20 Mar 1987	CVW-5	CV 41‡	F/A-18A	WestPac‡
23 Apr 1987	13 Jul 1987	CVW-5	CV 41	F/A-18A	WestPac
15 Oct 1987	12 Apr 1988	CVW-5	CV 41	F/A-18A	WestPac/IO
18 Oct 1988	09 Nov 1988	CVW-5	CV 41	F/A-18A	WestPac

**Major Overseas Deployments**

<i>Date of Departure</i>	<i>Date of Return</i>	<i>Air Wing</i>	<i>Carrier</i>	<i>Type of Aircraft</i>	<i>Area of Operation</i>
21 Jan 1989	24 Feb 1989	CVW-5	CV 41	F/A-18A	WestPac
27 Feb 1989	09 Apr 1989	CVW-5	CV 41	F/A-18A	WestPac
31 May 1989	25 Jul 1989	CVW-5	CV 41	F/A-18A	WestPac
15 Aug 1989	11 Dec 1989	CVW-5	CV 41	F/A-18A	WestPac/IO
20 Feb 1990	06 Apr 1990	CVW-5	CV 41	F/A-18A	WestPac
02 Oct 1990	17 Apr 1991	CVW-5	CV 41	F/A-18A	WestPac/IO/ Persian Gulf

\* The squadron and CVG-19 were relieved aboard *Princeton* (CV 27) by Carrier Air Group 19X in the latter part of May 1951. Squadron officers were flown back to the States and the enlisted personnel were embarked on a transport ship for their return to NAS Alameda.

† The squadron deployed to MCAS Iwakuni, Japan, as part of the Marine Corps Unit Deployment Program and was assigned to MAG-12.

‡ The squadron was permanently forward deployed and home ported in Japan. Consequently, all future deployments for the squadron while embarked on *Midway* (CV 41) will cover only those operations outside the home waters of Japan.



*A formation of squadron A-4F Skyhawks fly over San Francisco, California, 1968.*



**Air Wing Assignments**

<i>Air Wing</i>	<i>Tail Code</i>	<i>Assignment Date</i>
CVG-153/CVAG-15/ CVG-15*	B/A†	26 Mar 1945
CVG-19/CVW-19§	B/NM‡	Nov 1949
COMFAIRLEMOORE§§		01 Dec 1969
CVW-11§§	NH	01 Dec 1969
CVW-15	NL	18 Jan 1982
COMLATWINGPAC		31 Aug 1982
CVW-9	NG	12 Nov 1982
COMLATWINGPAC		15 Sep 1984
MAG-12	NM**	04 Jun 1985
COMLATWINGPAC		14 Dec 1985
CVW-5	NF	01 Jul 1986

\* CVG-153 was redesignated Attack CVAG-15 on 15 November 1946 and then became CVG-15 on 1 September 1948.

† The tail code B was assigned to CVAG-15 on 12 December 1946 and changed to A on 4 August 1948.

‡ The tail code B was changed to NM in 1957. The effective date for this change was most likely the beginning of FY 58 (1 July 1957).

§ CVG-19 was redesignated CVW-19 when Carrier Air Groups (CVG) were redesignated Carrier Air Wings (CVW) on 20 December 1963.

§§ The squadron was operationally assigned to CVW-11 and under the administrative command of Commander Fleet Air Lemoore. During the latter part of 1969 and early 1970 the squadron underwent transitional training with VA-122 in the A-7 Corsair II.

\*\* While deployed to MCAS Iwakuni and assigned to MAG-12 the squadron used the NM tail code.



*A squadron A-7E Corsair II in flight with a low-visibility paint scheme, 1982.*

**Unit Awards Received—Continued**

<i>Unit Award</i>	<i>Inclusive Dates Covering Unit Award</i>	
KLM	17 Jan 1991	28 Feb 1991
NUC	05 Dec 1950	May 1951
	15 Apr 1952	18 Oct 1952
	28 Oct 1966	21 May 1967
	26 Jan 1968	23 Jul 1968
	07 Dec 1970	24 Jun 1971
	09 Mar 1972	04 Nov 1972
	17 Jan 1991	07 Feb 1991
KPUC	05 Dec 1950	May 1951
KSM	01 Dec 1950	31 May 1951
	14 Apr 1952	24 Apr 1952
	30 Apr 1952	21 Oct 1952
AFEM	03 Apr 1960	04 Apr 1960
	26 Apr 1960	27 Apr 1960
	22 May 1961	27 May 1961
	05 Mar 1964	13 Mar 1964
	12 May 1964	14 May 1964
	05 Jun 1964	10 Jun 1964
	13 Jun 1964	17 Jun 1964
	31 Aug 1964	06 Nov 1964
	14 Nov 1964	21 Nov 1964
	26 May 1965	03 Jun 1965
	23 Jan 1968	22 Mar 1968
	17 Sep 1969	
	28 Sep 1969	04 Oct 1969
MUC	05 May 1969	03 Nov 1969
	07 Sep 1989	25 Oct 1989
NEM	09 May 1981	18 Oct 1981
RVNGC	19 Oct 1965	20 Oct 1965
	23 Oct 1965	28 Oct 1965
	22 Nov 1965	
	24 Nov 1965	
	06 Dec 1965	
	15 Nov 1966	16 Nov 1966
	20 Nov 1966	21 Nov 1966
	06 Dec 1966	
	15 Dec 1966	
	06 Jan 1967	
	09 Jan 1967	
	30 Jan 1967	
	21 Feb 1967	
	25 Feb 1967	
	03 Mar 1967	04 Mar 1967
	06 Mar 1967	07 Mar 1967
	09 Mar 1967	
	30 Mar 1967	
	11 Apr 1967	
	15 Apr 1967	
	24 Apr 1967	
	26 Apr 1967	
	27 Jan 1968	
	31 Jan 1968	03 Feb 1968
	05 Feb 1968	03 Mar 1968
	27 Mar 1968	06 Apr 1968

**Unit Awards Received**

<i>Unit Award</i>	<i>Inclusive Dates Covering Unit Award</i>	
NAVE	01 Jul 1965	31 Dec 1966
	01 Jul 1968	31 Dec 1969
	01 Jan 1989	31 Dec 1989
	01 Jan 1990	31 Dec 1990
SASM	02 Nov 1990	14 Mar 1991

**Unit Awards Received—Continued**

<i>Unit Award</i>	<i>Inclusive Dates Covering Unit Award</i>	
	08 Apr 1968	
	26 Apr 1968	
	28 Apr 1968	01 May 1968
	08 May 1968	
	11 May 1968	
	31 May 1968	
	02 Jun 1968	
	17 May 1969	03 Jun 1969
	15 Jun 1969	30 Jun 1969
VNSM	18 Jul 1965	13 Aug 1965
	10 Sep 1965	01 Oct 1965
	08 Oct 1965	29 Oct 1965
	13 Nov 1965	17 Dec 1965
	12 Nov 1966	18 Dec 1966
	03 Jan 1967	07 Feb 1967
	13 Feb 1967	16 Mar 1967
	28 Mar 1967	28 Apr 1967
	25 Jan 1968	04 Mar 1968
	25 Mar 1968	08 Apr 1968
	16 Apr 1968	
	24 Apr 1968	12 May 1968
	20 May 1968	14 Jun 1968
	25 Jun 1968	23 Jul 1968
	05 May 1969	04 Jun 1969
	15 Jun 1969	01 Jul 1969
	12 Jul 1969	30 Jul 1969
	14 Aug 1969	12 Sep 1969
	08 Oct 1969	31 Oct 1969
	07 Dec 1970	30 Dec 1970
	12 Jan 1971	04 Feb 1971
	19 Feb 1971	01 Apr 1971

**Unit Awards Received—Continued**

<i>Unit Award</i>	<i>Inclusive Dates Covering Unit Award</i>	
	09 Apr 1971	26 Apr 1971
	03 May 1971	17 May 1971
	29 May 1971	23 Jun 1971
	08 Mar 1972	25 Mar 1972
	03 Apr 1972	22 Apr 1972
	01 Jun 1972	27 Jun 1972
	07 Jul 1972	04 Aug 1972
	14 Aug 1972	05 Sep 1972
	15 Sep 1972	02 Oct 1972
	12 Oct 1972	31 Oct 1972



*A squadron F/A-18A Hornet in flight, loaded with weapons, 1990.*



*A squadron F/A-18A Hornet over Midway (CV 41) in 1987.*

## VFA-195

### Lineage

Established as Torpedo Squadron NINETEEN (VT-19) on 15 August 1943.

Redesignated Attack Squadron TWENTY A (VA-20A) on 15 November 1946.

Redesignated Attack Squadron ONE HUNDRED NINETY FIVE (VA-195) on 24 August 1948.

Redesignated Strike Fighter Squadron ONE HUNDRED NINETY FIVE (VFA-195) on 1 April 1985. The first squadron to be assigned the VA-195 and VFA-195 designation.

### Squadron Insignia and Nickname

The squadron's first insignia was approved by CNO on 4 March 1944. Colors for the lion cub and torpedo



*The lion cub was the squadron's first insignia.*

whiskers; yellow scarf and line to the torpedo; dark brown bazooka.

A new insignia was approved by CNO on 18 April 1949. Two versions of the tiger and parrot insignia exist and the records do not identify which one was the officially approved insignia. There are no color markings available for either insignia.

The squadron adopted the shield insignia at a later date. There are no records available to identify when



*The squadron's second insignia was the tiger and parrot design. This is one of the designs on file; unfortunately, the insignia records do not identify which design was approved by CNO.*



*This is the other tiger and parrot design on file in the squadron's insignia records.*



*The squadron adopted the helmet and shield insignia sometime in the 1950s.*



*In 1985, the squadron adopted the stylized eagle insignia design.*

this insignia was approved. It is believed the use of the shield insignia began sometime in the 1950s. There are no color markings available on this insignia.

A new insignia was approved by CNO on 30 August 1985. Colors for the eagle insignia are: a green background outlined in a checker board pattern of green, black and gray squares; gray stylized eagle outlined in white, with a white head, a red eye, and a yellow beak and claws; black bomb and missiles outlined in white; silver scrolls outlined in black with black lettering.

Nicknames: Tigers, 1949-early 1950s.

Dambusters, early 1950s-present.

### Chronology of Significant Events

**18 Jul 1944:** The squadron flew its first combat mission when it conducted preinvasion strikes against Guam.

**Jul-Oct 1944:** The squadron flew combat strikes against Guam, Palau, the Bonin and Volcano Islands, Mindanao, Visayans, Luzon, Okinawa and Formosa.

**24 Oct 1944:** Squadron aircraft participated in strikes against the Central Japanese Task Force in the Sibuyan Sea, which included the super battleship *Musashi*. Three of the squadron's personnel, Lieutenants Joseph C. Black and Max E. Gregg and Lieutenant (jg) Edward H. Schulke, were awarded the Silver Star for their actions during this strike.

**25 Oct 1944:** Squadron aircraft participated in the Battle Off Cape Engano, strikes against the Japanese Northern Force composed primarily of carriers. The following squadron personnel were awarded the Navy Cross for their actions during this battle: Lieutenant Commander Frank C. Perry; Lieutenants Leonard R. Prater, Joseph C. Black, Max E. Gregg, Frederick Doll, Jr., James C. West, Leonard P. Mathias, Donald W. McMillan, Richard D. Greer, Jr., and Gordon B. Whelpley; Lieutenant (jg)s Frank A. Fox, Morris R. Goebel, James H. Langrall, Ray J. Stacy, Robert F. Durian, William R. Garrett, John S. McDonald, Edward H. Schulke, Edward



A close-up of squadron AD-4 Skyraiders, loaded with weapons, aboard *Princeton* (CV 37) during their combat deployment to Korea from 1950–1951.



The Hwachon Reservoir Dam under attack by squadron AD-4 Skyraiders, 1 May 1951.

C. Myers, Jr., Irvin Kramer, Jr. and James E. Sipprell; and Ensigns Mercer L. Jackson, Jr., Wallace F. Leeker, Frederick Schuler and Warner W. Tyler.

**5 Nov 1944:** Squadron aircraft participated in an attack on the *Nachi*, a Japanese heavy cruiser, which was making a sortie out of Manila Bay. The cruiser was sunk and Lieutenant (jg)s Robert F. Durian, James E. Sipprell and Ray J. Stacy were awarded a Gold Star in lieu of their second Navy Cross for their actions in this engagement. Lieutenant Joseph C. Hebert was awarded a Navy Cross for actions in this strike.

**5 Dec 1950:** The squadron flew its first combat mission since the end of World War II, flying close air support missions for U.S. Marines near Chosen Reservoir in North Korea.

**1 May 1951:** The squadron's AD-4 Skyraiders made a torpedo strike against the flood gates of the Hwachon Reservoir Dam. The purpose of the mission was to destroy the flood gates and raise the level of the river to form a natural barrier against the enemy's advance. It was from this mission that the squadron derived its nickname, Dambusters.

**23 Jun 1952:** The squadron, along with units from two other carrier air groups and the Fifth Air Force, conducted coordinated air strikes against the Suiho hydroelectric plant on the Yalu River and the Kyosen Number Three hydroelectric plant. Squadron aircraft participated in attacks against other hydroelectric plants the following day.

**11 Jul 1952:** Squadron aircraft participated in one of the major joint Navy, Air Force and Marine Corps air strikes of the war, hitting industrial targets in North Korea's capital city of Pyongyang.

**Aug–Oct 1964:** The squadron participated in special operations, flying escort and reconnaissance sorties in support of U.S. operations in Vietnam and Laos.

**20 Apr 1967:** Commander S. R. Chessman, the squadron's executive officer, was awarded the Silver Star for his actions in planning and executing a successful strike against a Haiphong thermal power plant, accomplishing the mission without the loss of a single aircraft.

**Mar 1968:** VA-195, along with other squadrons in CVW-19, conducted flight operations from *Ticonderoga* (CVA 14) in the Sea of Japan. These operations, part of Operation Formation Star, were conducted as part of a continuing show of American forces in the area following the capture of *Pueblo* (AGER 2) by North Korea on 23 January 1968.

**6 Mar 1972:** During night operations off *Kitty Hawk* (CVA 63) in Philippine waters, the squadron's commanding officer, Commander D. L. Hall, was lost when his aircraft crashed into the water astern of the carrier.

**Apr 1972:** Following the invasion by North Vietnam into South Vietnam the squadron participated in tactical air sorties against military and logistic targets in North Vietnam.

**9 May 1972:** Squadron aircraft participated in the mining of North Vietnamese harbors.

**10 May 1972:** VA-195 participated in the beginning of Linebacker I operations, concentrated air strikes against targets in North Vietnam above the 20th parallel.

**23 Nov 1973:** VA-195 deployed with CVW-11 embarked on *Kitty Hawk* (CV 63) as part of the first CV concept air wing deployment on the west coast. This concept consolidated all aspects of carrier aviation warfare into one air wing deployed on a single deck.

**Jul–Aug 1983:** *Ranger* (CV 61), with VA-195 embarked, was ordered to operate off the coast of Nicaragua in response to an unstable situation in

Central America and the possible invasion of Honduras by Nicaragua.

**Oct 1983–Jan 1984:** *Ranger*, with VA-195 embarked, was extended on station in the Arabian Sea due to the Iranian threat to block oil exports from the Persian Gulf.

**Nov 1986:** The squadron flew its F/A-18 Hornets from NAS Lemoore to NAF Atsugi, Japan, for operations with CVW-5 and *Midway* (CV 41), home ported at NS Yokosuka, Japan.

**Nov 1987–Feb 1988:** The squadron participated in Earnest Will Operations, the escorting of reflagged Kuwaiti tankers through the Persian Gulf.

**Sep 1988:** During the Summer Olympics in Seoul, Korea, the squadron was embarked on *Midway* and operating in the Sea of Japan to demonstrate U.S. support for a peaceful Olympics.

**Dec 1989:** *Midway*, with VFA-195 embarked, maintained station off the coast of the Philippines during an attempted coup in that country.

**Nov 1990–Jan 1991:** The squadron flew missions in support of Operation Desert Shield, the build up of American and Allied forces to counter a threatened invasion of Saudi Arabia by Iraq and as part of an economic blockade of Iraq to force its withdrawal from Kuwait.



*A squadron TBM-3E in flight, circa mid 1946 (Courtesy Robert Lawson Collection).*

### Home Port Assignments

<i>Location</i>	<i>Assignment Date</i>
NAAS Los Alamitos	15 Aug 1943
NAS Kahului	29 Feb 1944*
NAS San Diego	14 Dec 1944
NAS Alameda	20 Jan 1945
NAAS Santa Rosa	05 Feb 1945
NAS Kahului	09 Aug 1945*
NAS Barbers Point	03 Nov 1945
NAS Alameda	19 Aug 1946
NAS Moffett Field	03 Nov 1952
NAS Lemoore	13 Dec 1961
NS Yokosuka, Japan (NAF Atsugi & Misawa)	01 Jul 1986†

\* Temporary shore assignment while the squadron conducted training in preparation for combat deployment.

† VFA-195 was assigned to CVW-5 on 1 July 1986 as part of a program that has a permanently assigned carrier and air wing at an overseas home port. The home port for CVW-5 and *Midway* (CV 41) was NS Yokosuka, Japan. The squadron did not arrive in Japan until November 1986.



*Three squadron AD-6 Skyraiders on the deck of Yorktown (CVA 10) preparing to launch, 1957.*

### Commanding Officers

	<i>Date Assumed Command</i>
LT Leonard R. Prater (acting)	15 Aug 1943
LCDR Karl E. Jung	18 Aug 1943
LCDR Albert P. Coffin	22 Sep 1943

LCDR David E. Dressendorfer	31 Dec 1943
LCDR Frank C. Perry	26 Sep 1944
LCDR James F. McRoberts	24 Nov 1945
LCDR Melvin H. Warner	11 Aug 1947
LCDR Harry C. White	07 Aug 1948
LCDR Harold G. Carlson	26 Jun 1950
CDR Neil A. MacKinnon	28 Sep 1951
CDR August W. Elliott, Jr.	01 Dec 1952
CDR Lewis R. Hardy, Jr.	16 Jul 1954
CDR William A. Rawls	30 Sep 1955
CDR R. J. Mead	06 Sep 1957
CDR Fletcher H. Burnham	18 Jul 1958
CDR Harry N. O'Connor	Jul 1959
CDR George W. Blease	01 Jun 1960
CDR Walter E. Scholz	17 Mar 1961
CDR Anson D. Geiger	27 Apr 1962
CDR Robert F. Doss	29 Mar 1963
CDR J. V. Smith	28 Apr 1964
CDR Bertrand O. Larsen	12 Apr 1965
CDR Charles E. Hathaway	01 Apr 1966
CDR Samuel R. Chessman	28 Apr 1967
CDR W. H. Greiwe	24 Jul 1968
CDR C. W. Jorgensen	Jun 1969
CDR D. D. Hicks, Jr.	06 Mar 1970
CDR Paul F. McCarthy, Jr.	09 Feb 1971
CDR Donald L. Hall	30 Dec 1971
CDR Mace C. Gilfry	07 Mar 1972
CDR Norman D. Campbell	16 Mar 1973
CDR Brian D. Woods	01 Jun 1974
LCDR James R. Lee	02 Jun 1975
CDR William E. Newman	27 Aug 1976
CDR Robert C. Kaup	07 Oct 1977
CDR William C. Bowes	06 Oct 1978
CDR James M. Hays	13 Dec 1979
CDR Alexander M. Phillips	24 Mar 1981
CDR David I. Pierce	09 Jun 1982
CDR Kirwin S. Webster	01 Dec 1983
CDR W. O. King, Jr.	08 May 1985
CDR Patrick D. Money maker	10 Oct 1986
CDR Thomas G. Otterbein	15 Apr 1988
CDR Gregory C. Wooldridge	09 Aug 1989
CDR Randolph R. Robb	17 Oct 1990



*A formation of squadron A-4C Skyhawks during their combat deployment to Vietnam aboard Bon Homme Richard (CVA-31), 1965.*

### Aircraft Assignment

<i>Type of Aircraft</i>	<i>Date Type First Received</i>
TBM-1	1943*
TBM-1C	04 Nov 1943
TBM-3	Feb 1945
TBM-3E	Apr 1945
TBM-3Q	1946
AD-1	03 May 1947
AD-2	25 Aug 1948
AD-3	10 Jan 1949
AD-4	Jul 1950
AD-4L	Jun 1952
AD-4B	Jan 1953
AD-4NA	Feb 1953
AD-6	May 1954
A4D-2	01 Jul 1959
A4D-2N/A-4C†	May 1960
A-4E	Sep 1968
TA-4F	Oct 1968
A-7E	Feb 1970
F/A-18A	30 Sep 1985

\* The squadron received its first TBM-1s sometime in either late August or early September 1943.

† The A4D-2N designation was changed to A-4C in 1962.



*Three squadron A-7E Corsair IIs on the deck of Kitty Hawk (CVA 63) prepare to launch on a combat mission against Viet Cong positions, 1971.*

**Major Overseas Deployments**

<i>Date of Departure</i>	<i>Date of Return</i>	<i>Air Wing</i>	<i>Carrier</i>	<i>Type of Aircraft</i>	<i>Area of Operation</i>
23 Jun 1944	23 Nov 1944	CVG-19	CV 16*	TBM-1C	Pacific
18 Mar 1946	19 Aug 1946	CVG-19	CV 36†	TBM-3E	WestPac
11 Jan 1950	13 Jun 1950	CVG-19	CV 21	AD-3	WestPac
09 Nov 1950	09 Jun 1951	CVG-19	CV 37‡	AD-4	WestPac/Korea
21 Mar 1952	03 Nov 1952	CVG-19	CV 37	AD-4/4L	WestPac/Korea
14 Sep 1953	22 Apr 1954	CVG-19	CVA 34	AD-4B/NA	WestPac
02 Mar 1955	21 Sep 1955	CVG-19	CVA 34	AD-6	WestPac
09 Mar 1957	25 Aug 1957	CVG-19	CVA 10	AD-6	WestPac
01 Nov 1958	18 Jun 1959	CVG-19	CVA 31	AD-6	WestPac
21 Nov 1959	14 May 1960	CVG-19	CVA 31	A4D-2	WestPac
26 Apr 1961	13 Dec 1961	CVG-19	CVA 31	A4D-2N	WestPac
12 Jul 1962	11 Feb 1963	CVG-19	CVA 31	A-4C	WestPac
28 Jan 1964	21 Nov 1964	CVW-19	CVA 31	A-4C	WestPac/IO/Vietnam
21 Apr 1965	13 Jan 1966	CVW-19	CVA 31	A-4C	WestPac/Vietnam
15 Oct 1966	29 May 1967	CVW-19	CVA 14	A-4C	WestPac/Vietnam
28 Dec 1967	17 Aug 1968	CVW-19	CVA 14	A-4C	WestPac/Vietnam
14 Apr 1969	17 Nov 1969	CVW-19	CVA 34	A-4E	WestPac/Vietnam
06 Nov 1970	17 Jul 1971	CVW-11	CVA 63	A-7E	WestPac/Vietnam
17 Feb 1972	28 Nov 1972	CVW-11	CVA 63	A-7E	WestPac/Vietnam
23 Nov 1973	09 Jul 1974	CVW-11	CV 63	A-7E	WestPac/IO
21 May 1975	15 Dec 1975	CVW-11	CV 63	A-7E	WestPac
25 Oct 1977	15 May 1978	CVW-11	CV 63	A-7E	WestPac
13 Mar 1979	22 Sep 1979	CVW-11	CV 66	A-7E	Med
14 Apr 1981	12 Nov 1981	CVW-11	CV 66	A-7E	Med/IO
15 Jul 1983	29 Feb 1984	CVW-9	CV 61	A-7E	Central America/ WestPac/IO
09 Jan 1987	20 Mar 1987	CVW-5	CV 41§	F/A-18A	WestPac§
23 Apr 1987	13 Jul 1987	CVW-5	CV 41	F/A-18A	WestPac
15 Oct 1987	12 Apr 1988	CVW-5	CV 41	F/A-18A	WestPac/IO
18 Oct 1988	09 Nov 1988	CVW-5	CV 41	F/A-18A	WestPac
21 Jan 1989	24 Feb 1989	CVW-5	CV 41	F/A-18A	WestPac
27 Feb 1989	09 Apr 1989	CVW-5	CV 41	F/A-18A	WestPac
31 May 1989	25 Jul 1989	CVW-5	CV 41	F/A-18A	WestPac
15 Aug 1989	11 Dec 1989	CVW-5	CV 41	F/A-18A	WestPac/IO
20 Feb 1990	06 Apr 1990	CVW-5	CV 41	F/A-18A	WestPac
02 Oct 1990	17 Apr 1991	CVW-5	CV 41	F/A-18A	WestPac/IO/ Persian Gulf

\* The squadron departed Hawaii enroute to Eniwetok Atoll embarked on *Intrepid* (CV 11) and arrived there on 30 June 1944. On 9 July the squadron flew aboard *Lexington* (CV 16) in preparation for its combat deployment. The squadron's combat deployment ended on 23 November 1944 when they were transferred to *Enterprise* (CV 6) while at Ulithi Atoll. They arrived at Hawaii on 27 November and were transferred to *Long Island* (CVE 1) for the final leg of the return trip to the States, arriving at NAS San Diego on 14 December 1944.

† The squadron departed Hawaii enroute to Saipan embarked on *Hancock* (CV 19) and arrived there on 3 April 1946. On 20 April the squadron flew aboard *Antietam* (CV 36) for deployment to WestPac. During the squadron's deployment to WestPac it was temporarily shore based at Saipan on several occasions.

‡ The squadron and CVG-19 were relieved aboard *Princeton* (CV 37) by Carrier Air Group 19X. Squadron aircraft were transferred to VA-55. The officers were flown back to the States and the enlisted personnel were transferred to USAT *General Nelson M. Walker* for transportation back to NAS Alameda.

§ The squadron was permanently forward deployed and home ported in Japan. Consequently, all future deployments for the squadron will cover only those operations outside the home waters of Japan.



*A formation of squadron A-7E Corsair IIs in low-visibility paint scheme, circa 1982–1983.*

**Air Wing Assignments**

<i>Air Wing</i>	<i>Tail Code</i>	<i>Assignment Date</i>
CVG-19/CVAG-19/ CVG-19/CVW-19*	A/B/NM†	15 Aug 1943
COMFAIRLEMOORE		01 Dec 1969
CVW-11	NH	1970
CVW-15	NL	18 Jan 1982
COMLATWINGPAC		01 Oct 1982
CVW-9	NG	12 Nov 1982
COMLATWINGPAC		15 Sep 1984

**Air Wing Assignments—Continued**

<i>Air Wing</i>	<i>Tail Code</i>	<i>Assignment Date</i>
CVW-5	NF	01 Jul 1986

\* CVG-19 was redesignated CVAG-19 on 15 November 1946. On 1 September 1948 CVAG-19 was redesignated CVG-19. CVG-19 was redesignated CVW-19 when Carrier Air Groups (CVG) were redesignated Carrier Air Wings (CVW) on 20 December 1963.

† The tail code A was assigned to CVAG-19 on 12 December 1946 and changed to B on 4 August 1948. The tail code B was changed to NM in 1957. The effective date for this change was most likely the beginning of FY 58 (1 July 1957).



*A squadron F/A-18A Hornet in flight, 1986. The aircraft has the tail code NM but the squadron was not assigned to CVW-19 when it received its Hornets.*



**Unit Awards Received**

<i>Unit Award</i>	<i>Inclusive Dates Covering Unit Award</i>	
NAVE	01 Jan 1970	30 Jun 1971
PUC	18 Jul 1944	05 Aug 1944
	06 Sep 1944	06 Nov 1944
Campaign Medal		
(Asiatic Pacific)	18 Jul 1944	27 Aug 1944
	31 Aug 1944	14 Oct 1944
	10 Oct 1944	23 Nov 1944
SASM	02 Nov 1990	14 Mar 1991
KLM	17 Jan 1991	28 Feb 1991
NUC	05 Dec 1950	10 Aug 1951
	15 Apr 1952	18 Oct 1952
	28 Oct 1966	21 May 1967
	26 Jan 1968	23 Jul 1968
	07 Dec 1970	24 Jun 1971
	09 Mar 1972	04 Nov 1972
	17 Jan 1991	07 Feb 1991
KPUC	05 Dec 1950	10 Aug 1951
KSM	01 Dec 1950	31 May 1951
	14 Apr 1952	24 Apr 1952
	30 Apr 1952	21 Oct 1952
AFEM	03 Apr 1960	04 Apr 1960
	26 Apr 1960	27 Apr 1960
	22 May 1961	27 May 1961
	05 Mar 1964	13 Mar 1964
	12 May 1964	14 May 1964
	05 Jun 1964	10 Jun 1964
	13 Jun 1964	17 Jun 1964
	31 Aug 1964	06 Nov 1964
	14 Nov 1964	21 Nov 1964
	26 May 1965	03 Jun 1965
	17 Mar 1968	21 Mar 1968
	17 Sep 1969	
	28 Sep 1969	04 Oct 1969
MUC	05 May 1969	03 Nov 1969
	01 Jan 1987	30 Jun 1988
	07 Sep 1989	25 Oct 1989
NEM	09 May 1981	18 Oct 1981
RVNGC	19 Oct 1965	20 Oct 1965
	23 Oct 1965	28 Oct 1965
	22 Nov 1965	
	24 Nov 1965	
	06 Dec 1965	
	15 Nov 1966	16 Nov 1966
	20 Nov 1966	21 Nov 1966
	06 Dec 1966	
	15 Dec 1966	
	06 Jan 1967	

**Unit Awards Received—Continued**

<i>Unit Award</i>	<i>Inclusive Dates Covering Unit Award</i>	
	09 Jan 1967	
	30 Jan 1967	
	21 Feb 1967	
	25 Feb 1967	
	03 Mar 1967	04 Mar 1967
	06 Mar 1967	07 Mar 1967
	09 Mar 1967	
	30 Mar 1967	
	11 Apr 1967	
	15 Apr 1967	
	24 Apr 1967	
	26 Apr 1967	
	27 Jan 1968	
	31 Jan 1968	03 Feb 1968
	05 Feb 1968	03 Mar 1968
	27 Mar 1968	06 Apr 1968
	08 Apr 1968	
	26 Apr 1968	
	28 Apr 1968	01 May 1968
	08 May 1968	
	11 May 1968	
	31 May 1968	
	02 Jun 1968	
	17 May 1969	03 Jun 1969
	15 Jun 1969	30 Jun 1969
VNSM	18 Jul 1965	13 Aug 1965
	10 Sep 1965	01 Oct 1965
	08 Oct 1965	29 Oct 1965
	13 Nov 1965	17 Dec 1965
	12 Nov 1966	18 Dec 1966
	03 Jan 1967	07 Feb 1967
	13 Feb 1967	16 Mar 1967
	28 Mar 1967	28 Apr 1967
	25 Jan 1968	04 Mar 1968
	25 Mar 1968	08 Apr 1968
	16 Apr 1968	
	24 Apr 1968	12 May 1968
	20 May 1968	14 Jun 1968
	25 Jun 1968	23 Jul 1968
	05 May 1969	04 Jun 1969
	15 Jun 1969	01 Jul 1969
	12 Jul 1969	30 Jul 1969
	14 Aug 1969	12 Sep 1969
	08 Oct 1969	31 Oct 1969
	07 Dec 1970	30 Dec 1970
	12 Jan 1971	04 Feb 1971
	19 Feb 1971	01 Apr 1971

**Unit Awards Received—Continued**

<i>Unit Award</i>	<i>Inclusive Dates Covering Unit Award</i>	
	09 Apr 1971	26 Apr 1971
	03 May 1971	17 May 1971
	29 May 1971	23 Jun 1971
	08 Mar 1972	25 Mar 1972
	03 Apr 1972	22 Apr 1972

**Unit Awards Received—Continued**

<i>Unit Award</i>	<i>Inclusive Dates Covering Unit Award</i>	
	01 Jun 1972	27 Jun 1972
	07 Jul 1972	04 Aug 1972
	14 Aug 1972	05 Sep 1972
	15 Sep 1972	02 Oct 1972
	12 Oct 1972	31 Oct 1972



*A squadron F/A-18A Hornet assigned to CVW-5 aboard Midway (CV 41).*

## VFA-203

### Lineage

Established as Attack Squadron TWO HUNDRED AND THREE (VA-203) on 1 July 1970.

Redesignated Strike Fighter Squadron TWO HUNDRED AND THREE (VFA-203) on 1 October 1989. The first squadron to be assigned the VA-203 and VFA-203 designation.

### Squadron Insignia and Nickname



*The squadron's one and only insignia, the Blue Dolphins. When the squadron was redesignated VFA the VA designation in the scroll was changed to VFA.*

The squadron's insignia was approved by CNO on 24 October 1974. Colors for the blue dolphin are as follows: a dark blue border with the upper half of the background blue and the lower half red, separated by a dark blue line; dark blue dolphin with white markings; blue scroll with dark blue outlines and lettering.

Nickname: Blue Dolphins, 1971-present.

### Chronology of Significant Events

**1 Jul 1970:** VA-203 was established as a reserve squadron under a new concept in the reorganization of the Naval Air Reserve Force. The reorganization was intended to make the reserves more compatible with active duty units and to increase the combat readiness of the Naval Air Reserve Force.

**15–22 May 1972:** The squadron deployed to NAS Oceana to participate in exercise Exotic Dancer V, designed to test multiservice operations under a unified command organization.

**Feb 1980:** The squadron participated in a combined NATO forces exercise conducted at NAS Bermuda called Safe Passage.

### Home Port Assignments

Location	Assignment Date
NAS Jacksonville	01 Jul 1970
NAS Cecil Field	01 Dec 1977

### Commanding Officers

	Date Assumed Command
CDR Walter N. Vance III	01 Jul 1970
CDR James S. Bassett	22 Jan 1972
CDR Bobby S. Morgan	29 Sep 1973
LCDR Jimmie W. Seeley	13 Sep 1975



*A couple of squadron A-4L Skyhawks in flight, circa early 1970s.*

**Commanding Officers—Continued**

	<i>Date Assumed Command</i>
CDR F. Francis Hughes, Jr.	20 Aug 1977
CDR A. Anthony Isgar	21 Jul 1979
CDR David A. Dollarhide	21 Feb 1981
CDR Jack C. Harris	21 Aug 1982
CDR George W. Weiler	1984

**Commanding Officers—Continued**

	<i>Date Assumed Command</i>
CDR Timothy G. Palmer	24 Apr 1985
CDR Thomas J. Verrengia	Jun 1986
CDR Ray K. Waddell	12 Dec 1987
CDR Richard A. Bailey	1989
CDR William C. Bailey	26 May 1990



*A squadron A-7A Corsair II in flight, circa 1974–1977.*

**Aircraft Assignment**

<i>Type of Aircraft</i>	<i>Date Type First Received</i>
A-4L	Jul 1971
A-7A	05 Apr 1974
A-7B	Aug 1977
A-7E	22 Sep 1983
F/A-18	05 Nov 1989

**Air Wing Assignments**

<i>Air Wing</i>	<i>Tail Code</i>	<i>Assignment Date</i>
CVWR-20	AF	01 Jul 1970

*A squadron F/A-18A Hornet at NAS Fallon, Nevada, May 1990 (Courtesy Robert Lawson Collection).*



## VFA-204

### Lineage

Established as Attack Squadron TWO HUNDRED FOUR (VA-204) on 1 July 1970.

Redesignation Strike Fighter Squadron TWO HUNDRED FOUR (VFA-204) on 1 May 1991. It is the first squadron to be assigned the VA-204 and VFA-204 designation.



The squadron's River Rattlers insignia was approved by CNO in 1970.



When the squadron was redesignated, the VA designation in the insignia scroll was changed to VFA.

### Squadron Insignia and Nickname

The squadron's insignia was approved by CNO on 31 August 1970. Colors for the insignia are: a yellow background outlined in red; white scroll outlined in red with blue lettering; green bomb outlined in black, with a yellow band on the nose and white markings on the fin; tan snake with green diamond and white markings, the underside of the snake is yellow with black markings; white fangs outlined in black; a red tongue with a dark pink mouth, outlined in red and a yellow eye with a red pupil; the entire snake is outlined in black.

Nickname: River Rattlers, 1970s-present.

### Chronology of Significant Events

**1 Jul 1970:** VA-204 was a reserve squadron established as part of a reorganization intended to increase the combat readiness of the Naval Air Reserve Force.

**May 1972:** The squadron participated in exercise Exotic Dancer V, designed to test multiservice operations under a unified command organization.

**Feb 1980:** VA-204 participated in a combined NATO forces exercise conducted near NAS Bermuda called Safe Passage.

### Home Port Assignments

Location	Assignment Date
NAS Memphis	01 Jul 1970
NAS New Orleans	Jan 1978

### Commanding Officers

	Date Assumed Command
CDR A. R. Scharff, Jr.	01 Jul 1970
CDR Theodore B. Hannah	01 Jul 1972
CDR Sidney C. Dabbs	12 Jan 1974
CDR Kenneth C. Juergens	12 Jul 1975
CDR James S. Greenwood	15 Feb 1977
CDR Norris J. Flagler	23 Sep 1978
CDR James A. Cook	22 Mar 1980
CDR Edwin R. Phelps III	24 Oct 1981
CDR Joseph A. Chronic	08 Jan 1983
CAPT Kenneth A. McCluskey	14 Apr 1984
CDR Donald R. Roesh	02 Mar 1985
CDR Robert O. Buschmann	13 Sep 1986
CDR Douglas R. Fischer	19 Mar 1988
CDR Keith R. LaFlair	Jul 1989
CDR Ronald J. Roshelli	Jul 1990
CDR D. L. Kloepfel	Jul 1991



A squadron A-4L Skyhawk comes in for a landing aboard Saratoga (CV 60).



A squadron A-7E Corsair II comes in for a landing, 1984.

**Aircraft Assignment**

<i>Type of Aircraft</i>	<i>Date Type First Received</i>
A-4C	01 Jul 1970
A-4L	Aug 1970
A-7B	15 Mar 1978
A-7E	Jun 1986
F/A-18A	Apr 1991

**Air Wing Assignments**

<i>Air Wing</i>	<i>Tail Code</i>	<i>Assignment Date</i>
CVWR-20	AF	01 Jul 1970

**Unit Awards Received**

<i>Unit Award</i>	<i>Inclusive Dates Covering Unit Award</i>	
NAVE	01 Jan 1984	31 Dec 1984



*A squadron A-7E Corsair II flies over New Orleans, Louisiana, 1984.*



*A squadron F/A-18A Hornet, 1992 (Courtesy Robert Lawson Collection).*

## VFA-303

### Lineage

Established as Attack Squadron THREE HUNDRED THREE (VA-303) on 1 July 1970.

Redesignated Strike Fighter Squadron THREE HUNDRED THREE (VFA-303) on 1 January 1984.

Disestablished on 31 December 1994. The first squadron to be assigned the VA-303 and VFA-303 designation.



*The squadron's Golden Hawks insignia.*

black markings and a red lightning bolt emanating from its beak; the Corsair II design is white; blue scrolls outlined in gold with gold lettering.

A modification to the above insignia was approved by CNO on 24 April 1984. The bridge design was replaced by brown mountains with white markings; the Corsair II design was replaced by a white hornet and the Attack Squadron 303 designation was changed to Strike Fighter Squadron 303. All the other colors remained the same as the previous insignia.



*Following the redesignation of the squadron, the designation in the insignia scroll was changed to Strike Fighter Squadron 303.*

### Chronology of Significant Events

**1 Jul 1970:** VA-303, a reserve squadron, established as part of a reorganization of the reserves intended to increase the combat readiness of the Naval Air Reserve Force.

**Apr 1971:** VA-303 was the first reserve squadron to transition to the A-7A Corsair II.

**Nov 1975:** The squadron deployed aboard *Ranger* (CV 61) for the annual active duty training and as part

of CVWR-30's tactical air mobilization test and the operational readiness exercise/inspection to ensure the squadron was seaworthy and combat ready.

**19 Oct 1985:** VFA-303 was the first reserve squadron to transition to the F/A-18 Hornet.

**25 Sep–20 Nov 1990:** A detachment of the squadron's F/A-18 Hornets and personnel, along with VFA-305, joined CVW-11 aboard *Abraham Lincoln* (CVN 72) for her transit from Norfolk to Alameda, via Cape Horn.

**Nov 1990:** A detachment of squadron aircraft and personnel deployed to NWC China Lake in direct support of Operation Desert Shield. Provided critical real world electronic warfare test and evaluation missions requiring aircraft fully functional with electronic warfare, Harm missile and electronic countermeasure suites.

**1993:** In early 1993 the squadron added the roles of Adversary and Fleet Support to its primary mission.



*A squadron A-4C Skyhawk, April 1971 (Courtesy Robert Lawson Collection).*

### Home Port Assignments

Location	Assignment Date
NAS Alameda	01 Jul 1970
NAS Lemoore	01 Jan 1984

### Commanding Officers

	Date Assumed Command
CDR William E. Nelson	01 Jul 1970
CDR Philip H. Benz	17 Jul 1971
CDR Olin A. Gray	21 Jan 1973
CDR Reid T. Melville	14 Dec 1974
CDR Alfred F. Talley	19 Jun 1976
CDR Thomas E. Gehman	17 Jun 1978
CDR Donald P. Smith	21 Jun 1980
CDR Harold Shorr	1982
CDR Richard A. Banks	23 Jul 1983
CDR Robert R. Greathouse	1984
CDR Jon L. Green	Oct 1985
CDR Scott H. Davis	11 Apr 1987



Two squadron A-7A Corsair IIs in flight, 1977.

**Commanding Officers—Continued**

	<i>Date Assumed Command</i>
CDR John S. Wood	22 Oct 1988
CDR Charles B. Askey	19 May 1990
CDR Barry C. Douglas	18 May 1991
CDR Ronald J. Smeltzer	19 Sep 1992
CDR Jeffrey L. Schram	08 Jan 1994

**Aircraft Assignment**

<i>Type of Aircraft</i>	<i>Date Type First Received</i>
A-4C	01 Jul 1970
A-7A	05 Apr 1971
A-7B	11 Aug 1977
F/A-18A	19 Oct 1985

**Air Wing Assignments**

<i>Air Wing</i>	<i>Tail Code</i>	<i>Assignment Date</i>
CVWR-30	ND	01 Jul 1970

**Unit Awards Received**

<i>Unit Award</i>	<i>Inclusive Dates Covering Unit Award</i>	
NAVE	01 Jul 1971	31 Dec 1972
	01 Jan 1987	31 Dec 1987
	01 Jan 1989	31 Dec 1989
	01 Jan 1991	31 Dec 1991



A squadron F/A-18A Hornet comes in for a carrier landing, circa 1986.



## VFA-305

### Lineage

Established as Attack Squadron THREE HUNDRED FIVE (VA-305) on 1 July 1970.

Redesignated Strike Fighter Squadron THREE HUNDRED FIVE (VFA-305) on 1 January 1987.

Disestablished on 31 December 1994. The first squadron to be assigned the VA-305 and VFA-305 designation.



The dagger design was the squadron's first insignia.



In 1974, the squadron adopted a the wolf head insignia. The designation in the scroll was changed from Attack Squadron 305 to Strike Fighter Squadron 305 in 1987.

### Squadron Insignia and Nickname

The squadron's first insignia was approved by CNO on 29 June 1971. Colors for the dagger insignia were: a gray background outlined in green; green diagonal strips; gold dagger outlined in black; gray scroll outlined in green with black lettering.

A new insignia was adopted and approved by CNO on 3 January 1974. Colors for the wolf insignia are: a white background outlined in brown; green diagonal strips outlined in brown; brown and white wolf's head, white and red eye, white mouth and teeth with a red tongue; white scroll outlined in brown with brown lettering.

Nicknames: The Hackers, 1971–1974.  
Lobos, 1974–1994.

### Chronology of Significant Events

1 Jul 1970: VA-305, a reserve squadron, established as part of a reorganization of the reserves intended to increase the combat readiness of the Naval Air Reserve Force.

Nov 1976: The squadron deployed aboard *Ranger* (CV 61) for the annual active duty training and as part of CVWR-30's tactical air mobilization test and the operational readiness exercise/inspection to ensure the squadron was seaworthy and combat ready and as part of a congressional ordered Reserve Air Test.

25 Sep–20 Nov 1990: The squadron's deployment with CVW-11 aboard *Abraham Lincoln* (CVN 72) was the first total integration of a reserve squadron with an active duty air wing for a long deployment in support of a direct fleet operational requirements. Squadron personnel participated in exercises and officer exchanges with the armed forces of Argentina and Chile and also flew drug interdiction missions during the deployment.

1993: In 1993 the squadron added the roles of Adversary and Fleet Support to its primary mission.



A line of squadron A-4C Skyhawks, 1971.

### Home Port Assignments

Location	Assignment Date
NAS Los Alamitos	01 Jul 1970
NAS Point Mugu	Jan 1971

A squadron A-7A Corsair II on a training flight, circa early 1970s.



**Commanding Officers**

	<i>Date Assumed Command</i>
CDR Steven B. Daggett	01 Jul 1970
CDR Louis F. Carson, Jr.	09 Jan 1972
CDR Earl L. Jackson, Jr.	08 Jul 1973
CDR Donald B. Norris	1975
CDR Ronald V. Boch	1976
CDR Louis E. Jones	21 Jan 1978
CDR Paul G. Giberson	30 Sep 1979
CDR Douglas L. Bailey	25 Apr 1981
CDR Jerry R. DeGiorgio	24 Oct 1982
CDR Robert W. Lind	23 Jul 1984
CDR Dennis J. Sapp	23 Feb 1986
CDR John P. Hazelrig	19 Sep 1987
CDR Jan D. Janiec	23 Oct 1988

**Commanding Officers—Continued**

	<i>Date Assumed Command</i>
CDR John K. McGuire, Jr.	21 Jul 1990
CDR P. B. Sanwick	20 Jul 1991
CDR Steven R. Sewell	14 Nov 1992
CDR Barry E. Rainey	12 Feb 1994

**Aircraft Assignment**

<i>Type of Aircraft</i>	<i>Date Type First Received</i>
A-4C	01 Jul 1970
A-4E	Dec 1971
A-7A	26 Jun 1972
A-7B	1978
F/A-18A	Jan 1987



*A formation of squadron A-7E Corsair IIs, 1984.*

**Major Overseas Deployments**

<i>Date of Departure</i>	<i>Date of Return</i>	<i>Air Wing</i>	<i>Carrier</i>	<i>Type of Aircraft</i>	<i>Area of Operation</i>
25 Sep 1990	20 Nov 1990	CVW-11	CVN-72	F/A-18A	East to West Coast Transit via Cape Horn



*A squadron F/A-18A Hornet touches down on Abraham Lincoln's (CVN 72) deck, October 1990.*

**Air Wing Assignments**

<i>Air Wing</i>	<i>Tail Code</i>	<i>Assignment Date</i>
CVWR-30	ND	01 Jul 1970
CVW-11		Sep 1990
CVWR-30	ND	Dec 1990

**Unit Awards Received**

<i>Unit Award</i>	<i>Inclusive Dates Covering Unit Award</i>	
NAVE	01 Oct 1976	30 Sep 1978
	01 Jan 1983	31 Dec 1983
	01 Jan 1990	31 Dec 1990
MUC	Nov 1976	Jan 1980



*A squadron F/A-18A Hornet at Naval Air Warfare Center Weapons Division Point Mugu, California, 1993.*

# ***Aircraft Data— Technical Information and Drawings***

*Compiled and written by*  
 Dr. William J. Armstrong  
 Historian  
 Naval Air Systems Command

## **A-3 (A3D) Skywarrior**

Early in the Second World War, the Navy began to explore the concept of a jet powered aircraft operating from carriers. Success encouraged further development of the concept, and early in the post war years the Navy began to consider jet power as a possible means of operating from carriers, aircraft that were large enough to provide a strategic bombing capability.

In January 1948, the Chief of Naval Operations issued a requirement to develop a long range, carrier-based attack plane that could deliver a 10,000 pound bomb load. The contract which the Navy awarded to the Douglas Aircraft Company on 29 September 1949

led to the development and production of the A3D Skywarrior. Unusually large for a carrier-based aircraft, the A3D quickly earned the nickname whale.

The Navy would never have a strategic bombing role in the defense of the United States, but the 282 Skywarriors which the Navy purchased served well in many roles. And as the last decade of the century began, the KA-3 and EA-3 soldiered on as tankers and electronic warfare aircraft.

First contract	29 September 1949
First flight	22 October 1952
First reported in squadron	By VAH-1 on 31 March 1956
Last delivery	January 1961
Number accepted	282



*An A3D-1 Skywarrior, 1956.*

### **Model Designations Accepted from the Manufacturer (New Builds)**

#### **XA3D-1:**

Experimental aircraft.

#### **YA3D-1:**

Prototype aircraft.

#### **A3D-1 (redesignated A-3A):**

The primary mission was attack of enemy surface targets. The A-3A had a conventional swept-wing structure, two turbo-jet engines, provisions for a three-man crew of pilot, bomber-assistant pilot and a gunner-navigator. There were provisions for twelve 4,500 pound thrust JATO bottles and for in-flight refueling. The airplane was a conventional swept-wing structure with an all metal wing and a semi-monocoque fuselage. The two turbo-jet engines were enclosed in under-wing nacelles. The tricycle landing gear, arresting gear, wing fold and tail fold mechanisms, single slotted wing flaps and power boost were operated by hydraulic power. The horizontal stabilizer was adjustable for trim in flight.

#### **A3D-2 (redesignated A-3B):**

At first designated A3D-1B, the A3D-2 differed from the A3D-1 by additional provisions for a fourth crew member. The leading edge slats were actuated automatically by aerodynamic loads. Anti-skid braking was provided. The JATO installation accommodated twelve 4,500 pound thrust bottles. In-flight refueling and tanker provisions were provided for the A3D-2. The following are technical specifications for the A-3B:

#### **Weight:**

Empty	37,077 lbs
Basic	37,545 lbs
Design	55,942 lbs
Combat	61,377 lbs
Max T.O. (Land)	78,000 lbs
Max T.O. (Cat)	73,000 lbs
Max landing (land)	56,000 lbs
Max landing (carrier)	49,000 lbs

#### **Dimensions:**

Wing area	770 sq ft
Wing span	72.5 ft
M.A.C.	140.14 in
Sweepback	36 degrees
Length	74.7 ft
Height	22.8 ft
Tread	10.4 ft

#### **Ordnance:**

Bombs	twelve 500 pound G.P. six 1,000 pound G.P. eight 1,600 pound A.P. four 2,000 pound G.P.
Mines	twelve 500 pound Mk 50

six 1,000 pound Mk 36  
four 2,000 pound Mk 25  
two 2,000 pound Mk 10  
six 1,000 pound Mk 52-1  
twelve 374 pound Mk 53-0  
four 2,000 pound XG-7  
one 1,558 pound Mk 12  
four 2,000 pound Mk 39-0

#### **Special stores:**

Guns/ammunition two 20 mm (M3)/500 rounds per gun  
tail turret system Aero 21B

Radar bomb director AN/ASB-1A

#### **Power plant:**

Two J57-P10 Pratt & Whitney turbojet dual rotor, axial flow engines.

Length 158 in  
Diameter 41 in

#### **Electronics:**

Radio altimeter AN/APN-22  
VOR homing AN/ARN-14E  
VHF trans-receiver AN/ARC-27A  
TACAN AN/ARN-21  
HF trans-receiver AN/ARC-38  
IFF transponder AN/APX-6B  
Interphone AN/AIC-4A  
Coder AN/APA-89  
UHF direction finder AN/ARA-25

#### **A3D-2P (redesignated RA-3B):**

The production version of the YA3D-2P. This reconnaissance aircraft carried a pressurized camera compartment with twelve camera stations. The compartment also housed camera controls, camera door controls and stowage for spare film magazines. The bomb bay accommodated photo-flash bombs and/or cartridges. Sighting equipment and view-finders were located in the cockpit.

#### **A3D-2C (redesignated EA-3B):**

The principal mission of the A3D-2Q was to search for enemy radar. Provisions were made for a crew of seven: pilot, navigator-assistant pilot, gunner-radioman and four ECM operators including an evaluator.

#### **A3D-2T (redesignated TA-3B):**

Trainer version.

### **Other Designations**

#### **A3D-1P (redesignated RA-3A):**

Same as A-3A except equipped for photography.

#### **A3D-1Q (EA-3A):**

Same as A-3A except equipped for countermeasures. Bomb capabilities removed.

**VA-3B:**

Similar to EA-3B aircraft except certain readily detachable electronic equipments removed from cabin area and the installation of equipment necessary for personnel accommodations.

**KA-3B:**

Similar to A-3A aircraft except modified to a tanker capability.

**EKA-3B:**

Model A-3B aircraft configured for the TACOS (Tanker Aircraft/Countermeasures or Strike) mission.

**NRA-3B:**

An A-3B equipped as test bed for Harpoon and Cruise missile guidance systems.

**ERA-3B:**

RA-3B modified to fleet electronic warfare support group configuration.

**Bureau Numbers**

XA3D-1	125412-125413
YA3D-1	130352
A3D-1	130353-130363
A3D-1	135407-135444
A3D-2	138902-138976
A3D-2	142236-142255
YA3D-2P	142256 (Aircraft never accepted)
A3D-2Q	142257 (Aircraft never accepted)
A3D-2W	142258 (Bureau number canceled)
A3D-2	142400-142407
A3D-2	142630-142665
A3D-2P	142666-142669
A3D-2Q	142670-142673
A3D-2	144626-144629
A3D-2P	144825-144847
A3D-2Q	144848-144855
A3D-2T	144856-144867
A3D-2	147648-147668

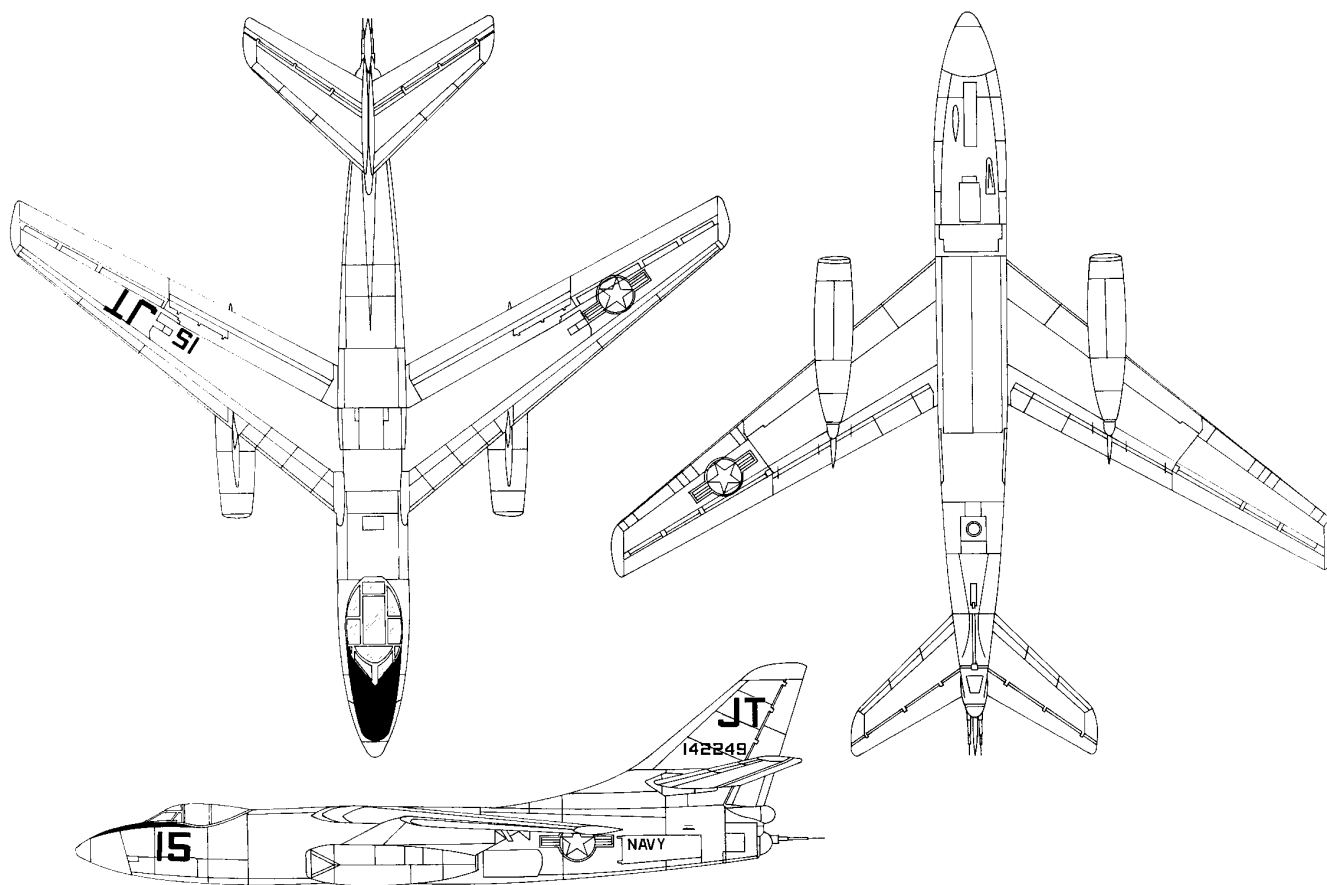

*Line drawings for an A-3 Skywarrior.*

## A4D (A-4) Skyhawk

By the early 1950s, jet power had matured to the point where the Navy became interested in using it for an attack aircraft. At that time, the AD Skyraider was the Navy's premier VA plane. The A4D Skyhawk (redesignated A-4) was the successor of the AD-1 Skyraider. Interdiction and close air support was what the aircraft was designed to do by the Douglas Company's aeronautical engineer, Mr. Ed Heinemann.

First contract	10 Sep 1952
First flight	22 Jun 1954
First reported in squadron	27 Sep 1956
Last delivery	27 Feb 1979
Number accepted	2,876



*An XA4D-1 Skyhawk takes off on its maiden flight from Edwards AFB, California, June 1954.*

### **Model Designations Accepted from the Manufacturer (New Builds)**

Only one model will list the technical specifications for the aircraft. All the other models will only identify the specific changes resulting in a new model designation.

#### **A4D-1 (Redesignated A-4A):**

The A4D-1 was a single seat aircraft designed as a light weight, carrier-based, turbo-jet plane whose primary mission was the destruction of enemy ground and surface targets. The structure was a conventional all metal semi-monocoque type. Fitted with automatically operated wing slats and hydraulically operated split flaps. Folding wings were not provided. The following are the technical specifications for the A4D-1:

#### Dimensions:

Wing area	260 sq ft
Wing span	27 ft 6 in
Length	39 ft 5 in
Height	15 ft 7 in

#### Weight:

Empty	8,286 lbs
Basic	8,375 lbs
Design	12,504 lbs
Combat	11,702 lbs
Max Takeoff (Field)	19,910 lbs
Max Takeoff (Catapult)	19,910 lbs
Max Landing (Field)	11,556 lbs
Max Landing (Arrest)	11,556 lbs

#### Ordnance:

Four 20 mm guns with 280 rounds on wing  
Fire control: six Aero 14B racks on wing  
Max load capacity 3,000 pounds

#### Electronics:

UHF Comm	AN/ARC-27A
IFF	AN/APX-6
IFF Coder	AN/APA-B9
UHF ADF	AN/ARA-25
TACAN (Backfit)	AN/ARN-21

#### Power Plant:

One Wright J65-W-4 axial flow engine.

#### **A4D-2 (Redesignated A-4B):**

The A4D-2 differed from the A4D-1 primarily by the incorporation of a pressure fueling-system, flight refueling provisions and a powered elevator system. One seat.

#### **A4D-2N (Redesignated A-4C):**

Improved A-4B with longer nose. One seat.

#### **A4D-5 (Redesignated A-4E):**

The A4D-5 was an A4D-2N with the J-52-P6 engine and two additional wing weapon stations. One crew.

#### **A-4F:**

Similar to A-4E but with J52-P-8A engine. ESCAPAC IC-3 ejection seat. One crew.

#### **A-4G:**

For Australian Navy.

#### **A-4H:**

For FMS.

#### **A-4K:**

For New Zealand.

#### **A-4KU:**

For FMS.

#### **A-4M:**

Similar to A-4F but with enlarged canopy. One crew.

#### **A-4N:**

For FMS.

### **Other Designations**

#### **TA-4B:**

Small, single-seat, delta wing, carrier-based, attack aircraft with tricycle landing gear and in-flight refueling capability.

- EA-4P:**  
 TA-4F modified for ECM missions.
- A-4L:**  
 A-4C with new engine, winglift spoilers, Walleye and Shrike missile capability, and improved avionics.
- OA-4M:**  
 A-4M modified for use by Marine Corps in high speed reconnaissance and tactical air control.
- A-4S:**  
 A-4B aircraft for use by Singapore.
- TA-4S:**  
 Trainer version of the A-4S.

- A-4E 151984-152100  
 TA-4E 152102-152106  
 A-4F 152101, 154172-154286, 154970-155069  
 TA-4F 152846-152878, 153459-153531, 153660-153690, 154287-154343, 154614-151657  
 A-4G 154903-154910  
 TA-4G 154911-154912  
 A-4H 155242-155289, 157395-157428, 157918-157925  
 TA-4H 157429-157134, 157926-157929  
 TA-4J 155070-155119, 156891-156950, 158073-158147, 158453-158527, 158712-158723, 159099-159104, 159546-159556, 153795-159798  
 A-4K 157904-157913  
 TA-4K 157914-157917  
 A-4KU 160180-160209  
 TA-4KU 160210-160215  
 A-4M 158148-158136, 158412-158435, 159470-159493, 159778-159794, 160022-160045, 160241-160264  
 A-4N 158726-158746, 159035-153052, 159075-159098, 159349-159350, 159515-159545, 159799-159824  
 A4D-5 149647-149666, 149959-150438, 151022-151261

**Bureau Numbers**

- XA4D-1 137812  
 A4D-1 137813-137831, 139919-139970, 142142-142235  
 - 142082-142141, 142116-142423, 142674-142953, 144868-145061  
 A4D-2N 145062-145146, 146460-146692, 147669-147819, 148304-148317, 148465-148614, 149487-149646, 150581-150600  
 A4D-3 145147-145156

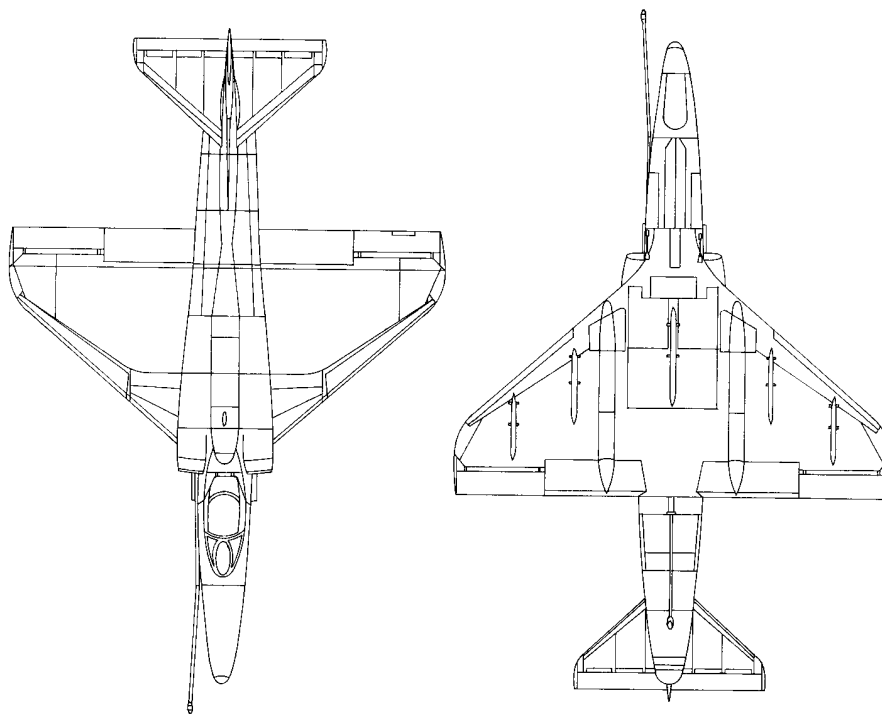

*Line drawings for an A-4 Skyhawk.*

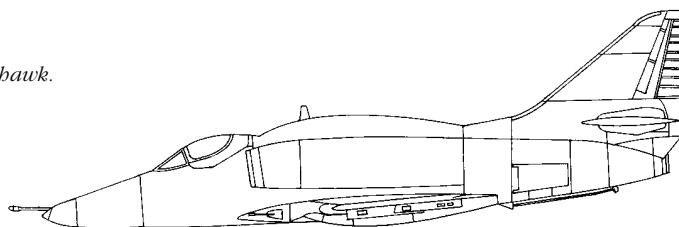



## A3J (A-5) Vigilante

The two aircraft that rank as the heaviest the Navy ever deployed aboard carrier are the A-3 Skywarrior and the A-5 Vigilante. Designed by North American to be a supersonic, allweather, strategic bomber, the Vigilante began life as the A3J and was redesignated A-5 in the general redesignation of Defense Department airplanes that occurred in 1962. The contractor referred to this design as the “North American General Purpose Attack Weapon” (NAGPAW). The first contract for this aircraft was awarded to North American by the Navy on 29 August 1956. Its first flight occurred two years later on 31 August 1958. Technical difficulties and strategic priorities prevented the A3J from ever serving in its intended role, but it did find a valuable place as a reconnaissance aircraft. The Vigilante was first reported in squadron by VAH-3 in June 1961, and completed its final deployment in September 1979. A total of 156 Vigilantes were bought.



*A YA3J-1 Vigilante takes off, circa late 1950s.*

### **Model Designations Accepted from the Manufacturer (New Builds)**

#### **YA3J-1:**

Prototype version of the A3J-1.

#### **A3J-1 (redesignated A-5A):**

Crew	two
Length	76 ft 6 in
Span:	
Open	53 ft
Folded	42 ft
Wing area	700 sq ft
Height:	
Tail upright	19 ft
Tail folded	14 ft 6 in

Weight:	
Empty	32,714 lbs
Combat	47,530 lbs
Combat Range	1,750 nm to 2,270 nm
Engines	two 17,000 lbs General Electric J79-8 or two 15,690 lbs General Electric J79-2
Ordnance	Internal stores including special weapons Two wing stations for external stores.

#### **A3J-2 (redesignated A-5B):**

Greater fuel capacity and two additional wing stations for ordnance.

#### **A3J-3P (redesignated RA-5C):**

Same as A-5B but equipped with day and night panoramic cameras that could scan horizon to horizon. Also equipped with cameras for still photography. Electronic systems included jamming and intelligence gathering capabilities.

### **Bureau Numbers**

YA3J-1	145157-145158
A3J-1	147850-147863
A3J-1	148924-148923
A3J-1	149276-149299
A3J-2	149300-149305
A3J-3P	149306-149317
A3J-3P	150823-150842
RA-5C	151615-151634
RA-5C	151726-151728
RA-5C	151962-151969 (all canceled)
RA-5C	156608-156653

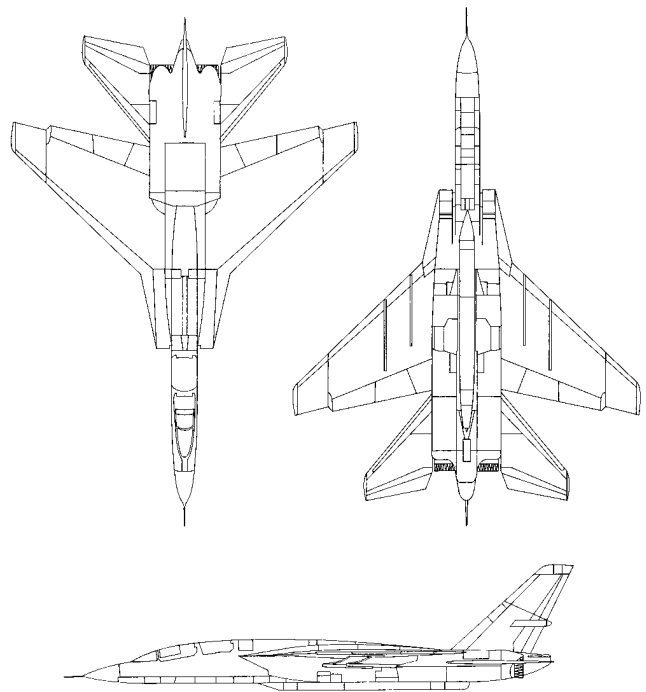

*Line drawings for an A3J (A-5) Vigilante.*

## A-6 Intruder

The Navy's experience with jet aircraft in the Korean conflict led to a requirement for a low-level attack bomber that could deliver ordnance against moving and fixed sea and land targets in all-weather and darkness. It was to be subsonic and capable of delivering nuclear as well as conventional ordnance thus being useful in both nuclear retaliatory and conventional conflicts. The Chief of Naval Operations issued the operational requirement (CA-01504) for this aircraft on 2 October 1956. On 5 March 1957 the Navy announced its intention to conduct a design competition for an aircraft that would meet the operational requirement. Eight manufacturers submitted eleven designs to this competition. The Navy selected the Grumman design. The aircraft that Grumman produced was a swept-wing two-place plane with exceptional loitering ability that could fly under enemy radar and carry greater and more varied stores than any naval attack aircraft of its time. It was powered by two Pratt & Whitney J-52 P-6 turbojet engines each with 8,500 pounds of thrust. The Intruder made its first flight 19 April 1960 as the A2F-1, a designation that became A-6A in the Department of Defense's uniform designation system.

First contract	26 March 1959
First flight	19 April 1960
First reported in squadron	February 1963 (A-6A in VA-42)
Initial operating capability	February 1963
Number accepted	687

### *Model Designations Accepted from the Manufacturer (New Builds)*

#### **A-6A:**

Originally designated A2F-1 and changed to A-6A in the DOD uniform designation system, this aircraft was first accepted by the Navy in February 1963 by VA-42. At light weights it could operate from short unprepared fields in close support of ground troops; at higher weights it could operate from catapult on long range special weapon strikes against heavily defended fixed targets. The A-6A had an attack-navigation and central digital computer system to find targets in all moving conditions.

#### **EA-6A:**

The original designation of the EA-6A was A2F-1Q. This aircraft retained a portion of the A-6A's attack capability but gave up much of its bombing and navigation equipment to make space for antennas to convert the attack plane into an effective electronic warfare aircraft.

#### **A-6B:**

The A-6B was a version of the A-6A design produced to meet the special wartime need of destroying ground-based anti-aircraft defenses. The A-6B was equipped to carry the Standard Anti-Radiation Missile (ARM) and had emitter location sensors.

#### **KA-6D:**

A-6A modified for use as aerial refueling tanker.

#### **A-6E:**

The Navy began to develop this version of the



*An early A2F-1 Intruder in flight, circa early 1960s.*

Intruder in the late 1960s. The first production deliveries were made in 1971. The A-6E was intended to reduce the necessary maintenance on the aircraft by increasing the reliability of its equipment and support. There were also improvements in the search and track radar, the computer and armament control equipment. The A-6E program involved new production A-6E's and the modification of A-6A's to the -6E configuration. The latter resulted in converting 240 A-6As to A-6Es.

#### A-6E TRAM:

The Target Recognition Attack Multisensor (TRAM) configuration of the A-6E greatly improved the aircraft's capability. Introduced in 1976, the TRAM version was equipped with a laser ranger and designator, a laser spot tracker and high resolution infrared sensor. The crew was able to view television quality images of their targets by day or night. The TRAM sensors greatly improve both ballistic and visual bombing accuracy. The TRAM version is equipped to launch laser-guided bombs and missiles. The TRAM's ASN-92 CAINS inertial navigation system gave the crew greater reliability and accuracy than was possible with the ASN-31. The TRAM version also had an Automatic Carrier Landing System (ACLS) and the Approach Power Compensator to provide totally automatic landing aboard carrier.

Specifications for the A-6E are as follows:

Length	54 ft 9 in
Span	53 ft
Height	16 ft 3 in
Height with wings folded	21 ft 11 in
Weight	26,896 pounds empty 60,400 pounds gross
Crew	2
Speed	Over 500 knots
Engines	2 Pratt & Whitney 9,300 lb J52-P-8
Ordnance	Five external store positions. Maximum load of 17,280 pounds

#### **Other Designations (Modifications of existing airframes)**

##### A-6C:

The A-6C was another special version of the A-6A produced to meet a wartime necessity. It was equipped with infrared sensors and Low Light Level Television (LLLT). The A-6C was known by the acronym TRIM which described the aircraft's mission as Trails, Roads Interdiction Multi-sensor. The A-6C's sensors were meant to detect the enemy's supply depots and truck traffic in Southeast Asia.

##### JA-6A:

A-6A modified as a test-bed for Circulation Control Wing research and development.

#### **Bureau Numbers**

A2F-1	147861-147867, 148615-148626, 149475-149486, 149935-149958, 151558-151594
A2F-1Q	151595-151612
A-6A	151780-151827, 152583-152646, 152891-152964, 154124-154171, 155137-155190, 155581-155721, 156994-157029, 158041-158052, 160421-160431
A-6B	154046-154099
KA-6D	158053-158072
A-6E	158041-158052, 158528-158539, 158787-158798, 159174-159185, 159309-159317, 159567-159581, 159895-159906, 160421-160431, 160993-160998, 161082-161093, 161100-161114, 161230-161241, 161659-161694, 161886-161897, 163520-163530

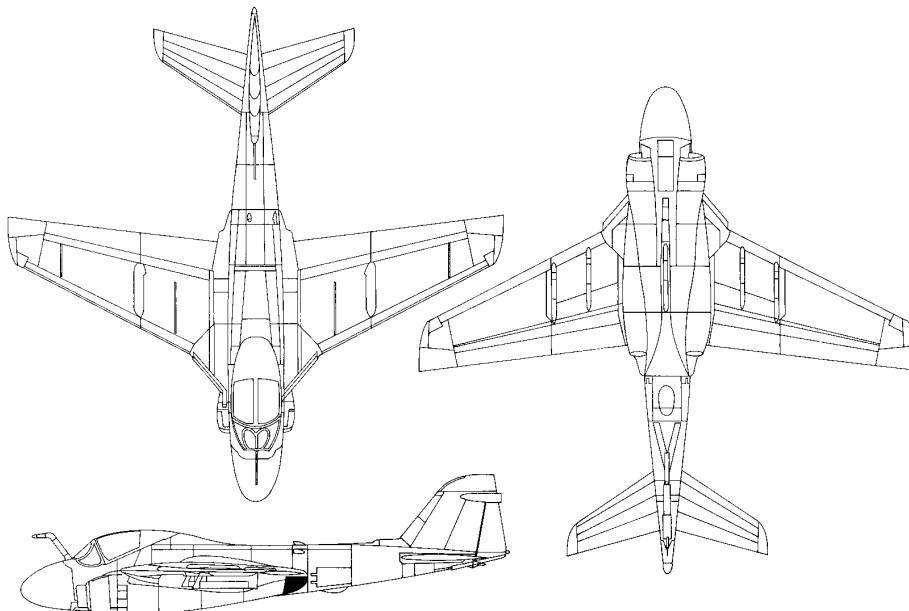

*Line drawings for an A-6 Intruder.*

## A-7 Corsair II

In May 1963, the Navy began a design competition for a light-attack, carrier-based aircraft to replace the Douglas A-4E Skyhawk. The new aircraft was to carry a larger ordnance payload than the Skyhawk and fly a greater combat radius. Vought, Douglas, Grumman, and North American responded to the Navy's invitation to bid. Vought was selected as the winner in February 1964. In March, the designation A-7A was approved for the new aircraft. The proposal by Vought engineers was based on their F-8 Crusader but without that fighter's adjustable wing incidence. It was to incorporate the Pratt & Whitney TF30-P-6 turbo-fan engine which had been developed for the F-111. The engine for the A-7, however, was not to have an afterburner. By using a proven design and engine, development of the A-7 was greatly accelerated over what it would have been if both airframe and powerplant were entirely new concepts.

The following are significant dates for the A-7:

The first flight occurred on 27 September 1965, and an A-7A Corsair II was delivered to VA-174 on 13 October 1966.

Carrier trials began aboard *America* (CVA 66) in November 1966.

Carrier trials ended with the final acceptance trials at sea aboard *Constellation* (CVA 64) in March 1967.

First tactical unit, VA-147 was established February 1967 and the second, VA-87, was established in June 1967.

First operational squadron deployed aboard *Ranger* (CVA 61) in November 1967.

CDR James C. Hill, writing in *Proceedings*, states that his squadron, VA-147, was established February 1967 and the A-7 "deployed into the combat environment of Southeast Asia on 4 November."

First A-7 combat action was December 1967, flown by VA-147 from *Ranger* (CVA 61).

### **Model Designations Accepted from Manufacturer (New Builds)**

#### **A-7A:**

A single-place, carrier-based, light attack, subsonic, medium range aircraft, the A-7A was powered by the Pratt & Whitney TF30-P-6 engine and designed to provide high attack utility and flexibility for close support and interdiction missions by virtue of a large number of external store stations to provide ordnance loading capacity and freedom of ordnance choice. A large internal fuel capacity made external fuel unnecessary for most missions while retaining maximum number of stations for armament. The A-7A's combat range was not less than 1,180 nautical miles with an average cruising speed never under 390 knots. The aircraft had an excellent overload capability in terms of wind-over-deck requirements, flying qualities and structural integrity. Features to expedite maintenance and airplane turnaround were important A-7A design characteristics. The A-7A was designed with a fixed wing incidence and a high-lift system composed of leading edge flaps and single slotted trailing edge flaps. Lateral control was provided by outboard ailerons and inboard spoilers.

#### **A-7B:**

Similar to A-7A except with improved engine, a Pratt & Whitney TF30-P-8 or -408, instead of the TF30-P-6 used in the A-7A. Also, variable position flaps, not found in the A-7A, were incorporated in the A-7B.

#### **A-7C:**

Initially intended to be a two-seat training version of the A-7B. When this plan was not pursued, the A-7C designation served as a "stop-gap" assigned to those aircraft accepted with the improvements intended for aircraft accepted as A-7E but lacking the Rolls Royce TF41-A-2 engine intended for the A-7E. All A-7Cs were powered by either the Pratt & Whitney TF30-P-8 or -408.



*An early A-7A Corsair II in flight, circa mid-1960s.*

**A-7D:**

For U.S. Air Force.

**A-7E:**

Made its combat debut when VA-146 and VA-147 deployed in April 1970 in *America* (CVA 66). The A-7E was similar to A-7B but with improved naval weapons delivery system, the AVQ-7B Head-Up Display, the ASN-91 Tactical Computer, the APQ-126 Forward Looking Radar, the ASN-90 Inertial Measurement Set and one 20 mm M61A1 gun instead of two 20 mm MK-12 guns. All A-7Es were powered by the Rolls Royce TF41-A-2 engine built, with modifications under license by Allison division of General Motors. The TF41, a non-afterburner engine, had a thrust of 15,000 pounds which was a considerable increase over the TF30-P-8 and -408. Specifications for the A-7E are as follows:

**Wing:**

Area	375 sq ft
Maximum span	38.73 ft
Folded span	23.77 ft
Aspect ratio	4
Sweep 1/4 chord	35°
MGC	130.08 in
Length	46.13 ft
Height	16.06 ft
Maximum tread	9.49 ft
<b>Weight (with TF41-A-2 engine):</b>	
Empty	18,546 lbs
Basic	19,576 lbs
Design	29,575 lbs
Combat (Clean A/P)	25,834 lbs
Maximum takeoff (Overload)	42,000 lbs
Maximum takeoff (Normal)	37,279 lbs
Maximum landing (Carrier)	25,300 lbs

**Ordnance:**

One 20 mm aircraft gun, M61.  
Two fuselage pylons for missiles.  
Six wing-mounted pylons with total capacity of 19,000 pounds.

**A-7H:**

For Greece.

**TA-7H:**

Two-seat trainer version of A-7H for Greece.

**A-7K:**

Two-seat A-7D for U.S. Air Force.

### Other Designations

**TA-7C:**

Two-seat trainer version, converted from A-7B and A-7C.

**A-7G:**

Designation of aircraft for Switzerland. Never delivered.

**EA-7L:**

Converted from TA-7C; modified to FEWSG configurations.

**A-7P:**

For Portugal, converted from A-7A.

**TA-7P:**

Two-seat trainer version for Portugal, converted from A-7A.

### Bureau Numbers

YA-7A	152580-152582
A-7A	152647-152685
A-7A	153134-153273
A-7A	154344-154360
A-7A	154913-154929 (Deliveries canceled)
A-7B	154361-154573 (Deliveries of 154557-154573 canceled)
A-7B	156178-156417 (Deliveries canceled)
A-7C	156734-156800
A-7E	156801-156890
A-7E	157435-157648 (Deliveries of 157595-157648 canceled)
A-7E	158002-158028
A-7E	158652-158681
A-7E	158819-158842
A-7E	159261-159308
A-7E	159638-159661
A-7E	159668-159679
A-7E	159967-160006
A-7E	160537-160566
A-7E	160613-160618
A-7E	160710-160739
A-7E	160857-160886 (Deliveries of 160881-160886 canceled)
A-7H	159622-159667
A-7H	159913-159966
TA-7H	161218-161222

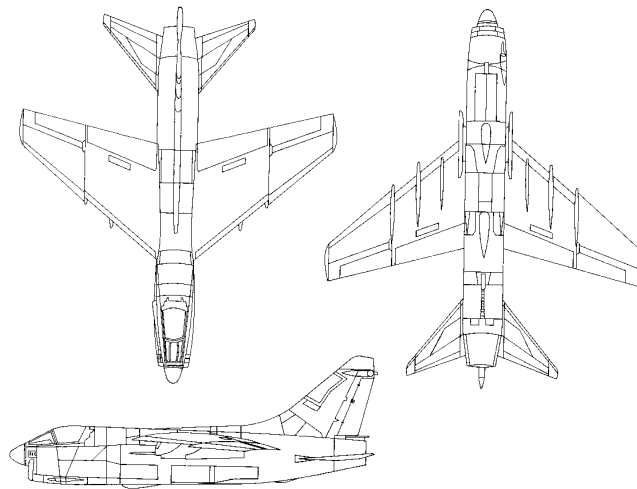

Line drawings for an A-7 Corsair II.

## AD (A-1) Skyraider

During World War II the Navy began looking for a new dive-bomber torpedo aircraft to meet its changing tactical and operational requirements. Several planes, among them the AD's direct predecessor, the SB2D/BTD, were developed by the Bureau of Aeronautics. Design difficulties and over-weight problems, however, ultimately led to a decision not to produce the SB2D/BTD. This in turn led to a new design which incorporated the good features of the SB2D/BTD while overcoming its inherent difficulties.

The AD series (later redesignated A-1) that emerged from the combined efforts of the Bureau of Aeronautics and Douglas, who was the contractor, had two particularly significant design aspects. First, great emphasis was placed on the importance of the stringent weight control policy. Secondly, the standard bulky, heavy bomb displacing gear was replaced by a light, explosive device which literally blew the bomb clear. In comparison with the most advanced operational dive-bombers in 1945, the AD's initial design compared most favorably with a 27 percent greater top speed and a capability of carrying up to 4,000 pounds of either bombs or torpedoes.

First contract	6 Jul 1944
First flight	18 Mar 1945
First reported in squadron	6 Dec 1946
Last delivery	Mar 1957
Last reported in squadron	31 Dec 1971
Number accepted	3,180

### *Model Designations Accepted from the Manufacturer (New Builds)*

Only one model will list the technical specifications for the aircraft. All the other models will only identify the specific changes resulting in a new model designation.

#### AD-1:

The initial single seat version of the Skyraider was powered by a 2,500 hp Wright R-3350-24W engine. Its details were as follows:

Weight empty	10,508 lbs
Gross (Scout)	13,924 lbs
Gross (Bomber)	18,030 lbs
Dimensions:	
Wing span	50 ft
Length	38 ft 4 in
Height	17 ft 6 in
Ordnance on Fuselage:	
Bombs	one 2,000 lbs
Depth bomb	one 650 lbs
Mine	one 2,000 lbs
Torpedo	one MK 13-3
Ordnance on Wings:	
Bombs	two 2,000 lbs
Depth Bombs	two 650 lbs
Mines	two 1,000 lbs
Rockets	two 11.75 in. Tiny Tim twelve HVAR
Torpedo	two MK 13-3
Guns	two 20 mm (M3)

#### AD-1Q:

AD-1 with countermeasures unit.



*An XBT2D-1 in flight. This was the first designation assigned to the AD Skyraider.*

**AD-2:**

Powered with the improved 2,700 hp Wright R-3350-26W engine.

**AD-2Q:**

AD-2 with countermeasures equipment.

**AD-3:**

Stronger fuselage, improved landing gear, new canopy design.

**AD-3N:**

Equipped for night attack.

**AD-3Q:**

Countermeasures equipment improved and relocated to provide better operation and crew comfort.

**AD-3W:**

Airborne early warning equipment.

**AD-4:**

The AD-4 was equipped with a strengthened landing gear, improved radar, G-2 compass, anti-G suit provisions, 4-20 mm cannon, and Aero 14 rocket launchers capable of carrying up to 50 pounds of bombs.

**AD-4W:**

Airborne early warning equipment.

**AD-4N:**

The primary mission of the AD-4N airplane was night attack and radar countermeasures.

**AD-4Q:**

Countermeasures equipment.

**AD-5 (Redesignated A-1E):**

A redesign of the aircraft. The AD-5 incorporated side by side seating for an assistant pilot. The revised crew arrangement facilitated all-weather operation and permitted utilization for long range navigation, radar search, spotting and observation, air support coordination, instrument training, pilot familiarization and other operations requiring a second crew member. Controls, armament and tactical equipment were located for single pilot operation. A single dive brake was provided for dive bombing and maneuvering control. The AD-5 could be converted rapidly aboard a carrier for operation as a passenger, cargo, ambulance or long range airplane by installation of appropriate conversion kits supplied as alternate equipment.

**AD-5N (Redesignated A-1G):**

Night attack version with radar countermeasures.

**AD-5W (Redesignated EA-1E):**

Airborne early warning version.

**AD-6 (Redesignated A-1H):**

The single-place airplane is conventional in design and structure, landing gear, canopy, flaps, wing folding and three fuselage dive brakes are operated hydraulically. Capable of low level bombing, the cen-

terline bomb station of the AD-6 was capable of carrying external stores up to 3500 pounds weight and 30 inches diameter. A combination 14 and 30 inch suspension bomb ejector was installed. A bomb director suitable for either high or low altitude bombing was also installed.

**AD-7 (Redesignated A-1J):**

The improvements in the AD-7 over its predecessors include the use of the R-3350-26WB engine and structural improvements in the wing to improve fatigue life.

### **Other Designations**

**AD-1U:**

AD-1 with radar countermeasures and tow target equipment. Deletion of armament and water injection equipment.

**XAD-1W:**

AD-1 with airborne early warning equipment. AD-3W prototype.

**XAD-2:**

Similar to XBT2D-1 except engine, increased fuel capacity.

**AD-2N:**

Equipped for night operations.

**AD-2U:**

AD-2 with radar countermeasure and tow target equipment. Deletion of armament and water injection equipment.

**XAD-3E:**

AD-3W modified for submarine search. Aero products propeller.

**AD-2W:**

AD-2 with airborne early warning equipment.

**AD-4L:**

AD-4 equipped for winterized version.

### **Bureau Numbers**

The Navy ordered the AD under the designation BT2D indicating that it was the second bomber torpedo aircraft which Douglas had designed for the Navy. The designation was later changed to A to reflect the Navy's decision to adopt the letter A in its designation system to replace the older system of T, B, SB indicating assault aircraft and the intention to combine these missions in one aircraft.

XBT2D-1	09085-09095, 09097, 09100-09106
XBT2D-1W	09107
XBT2D-1P	09096
XBT2D-1Q	09109
XBT2D-1N	09098-09099
XAD-2	09108
AD-1	09110-09351, 21742-22006

AD-1Q	09352-09392 (09387-09392 canceled)	AD-4NL	124725-124760
AD-2	122210-122365	AD-4Q	124037-124075
AD-2Q	122366-122372, 122374-122387	AD-4W	124076-124127, 124761-124777, 125765-125782, 126836-126875, 127921-127961
AD-2QU	122373	XAD-5	124006
AD-3	122729-122852	AD-5	132392-132476, 132478, 132637-132728, (132687-132728 canceled) 133854-134004 (133930-134004 canceled), (134076-134233 canceled)
AD-3E	122906-122907	AD-5N	132477, 132480-132636, 134974-135053, (135055-135138 canceled)
AD-3N	122908-122909, 122912-122922	AD-5Q	135054
AD-3Q	122854-122876	AD-5S	132479
AD-3S	122910-122911	AD-5W	132729-132792 (132731-132792 canceled), 133757-133776, 135139-135222, (138535-138568 canceled), 139556-139605
AD-3W	122877-122905	AD-6	134466-134637, 135223-135406, 137492-137632, 139606-139821, 142010-142081 (142010 canceled)
AD-4	122853, 123771-124005 (124007-124036 canceled), 127844-127853, 127861-127865, 127873-127879, 128917-128936, 128944-128970, 128979-129016	XAD-7	(142010 canceled)
AD-4B	127854-127860, 127866-127872, 128937-128943, 128971-128978, 132227-132391, (134005-134018 canceled)	AD-7	142011-142081, (142546-142629 canceled) (143050-143133 canceled)
AD-4N	124128-124156, 124725-124760, 125707-125741, 126876-126902, 126926-126946, 126970-126987, 127011-127018, 127880-127920		
AD-4NA	125742-125764, 126903-126925, 126947-126969, 126988-127010		

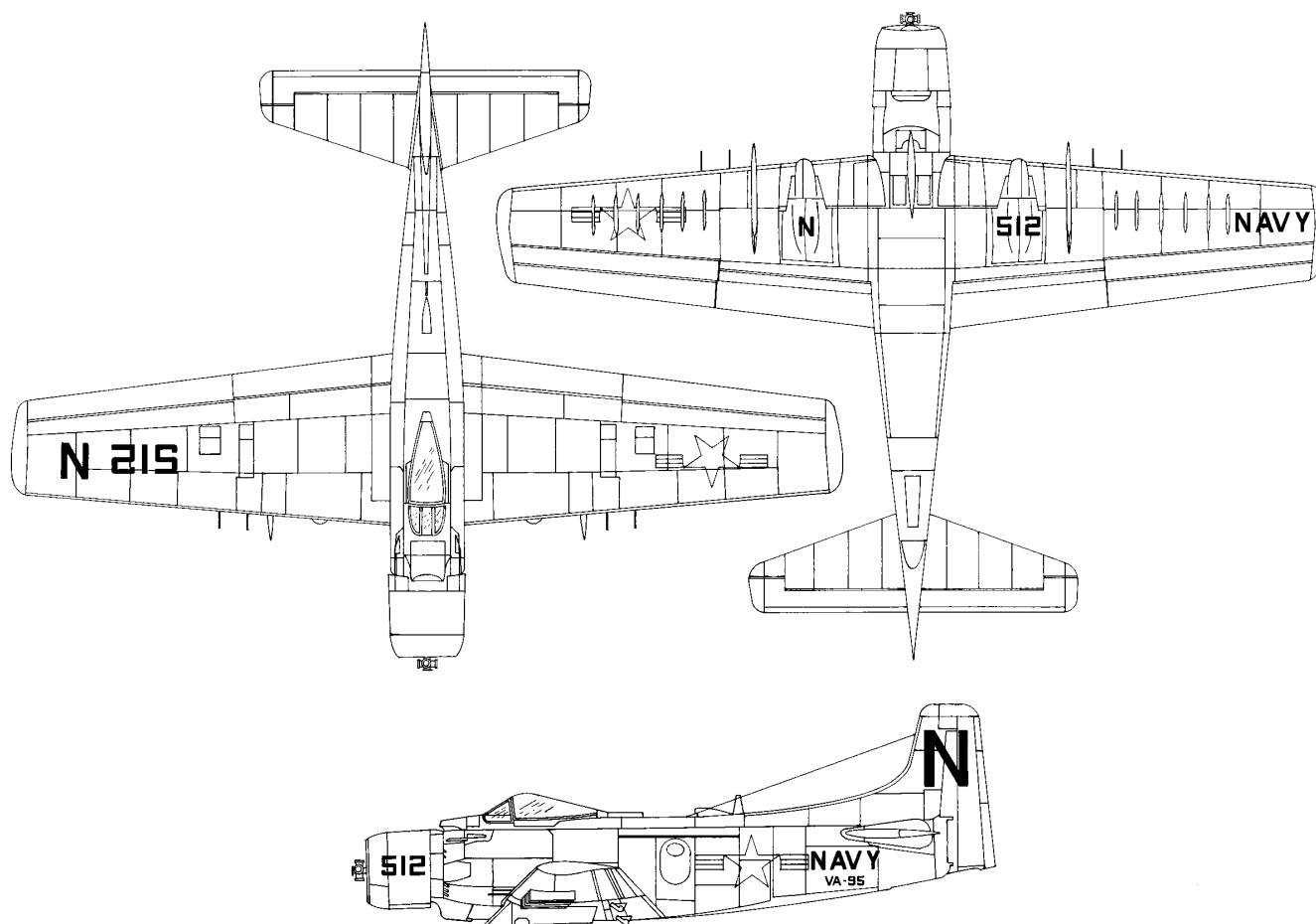

Line drawings for an AD (A-1) Skyraider.



## AF Guardian

The genesis of the Guardian begins in the late months of World War II as Grumman developed plans to replace the TBF Avenger. The normal continuation of the designation, TB2F, was used on a design for a two-engine aircraft that never was built but the designation was recognized by the Navy. The design which the Navy ordered in February 1945 was a single engine attack aircraft designated XTB3F. Because of the designation change of all Navy attack aircraft to "A" the TB3F entered squadron service in October 1950 as the AF. The aircraft was intended to work in hunter-killer pairs composed of an AF-2S and AF-2W.

First contract	19 February 1945
First flight	December 1946
First reported in squadron	18 October 1950
Last delivery	April 1953
Last reported in squadron	31 August 1955
Initial operational capability	October 1950
Number accepted	389



*An AF-2S Guardian in flight, June 1950.*

### **Model Designations Accepted from the Manufacturer (New Builds)**

XTB3F-1  
XTB3F-2S  
AF-2W  
AF-2S  
AF-3S

#### **AF-2S (Mission and Description):**

The AF-2S was the production development of the XTB3F-2S. Its primary mission was to attack enemy submarines after being directed to the target's position by the AF-2W. The AF-2S laid down a pattern of sonobuoys to determine exact location of the enemy submarine after which it launched its sonic-directed torpedo to complete the attack. Rockets and depth

bombs could be carried to augment the attack. The AF-2S was a three-place plane for operation ashore or aboard carriers. It was conventional in design and structure with an all-metal two spar wing and a semi-monocoque fuselage. Landing gear, slotted flaps, wing folding mechanism and pilot's canopy were hydraulically operated. Ailerons were of sealed balance type with spring tabs and one trim tab. Rudder had a combination trim and four to one ratio balance tab. Elevators were interconnected, one equipped with a spring tab and the other with a trim tab. Power plant installation was conventional with steel tube mount.

Specifications for the AF-2S are as follows:

Power plant	One Pratt & Whitney R-2800-48
Weight:	
Empty	14,658 lbs
Basic	15,336 lbs
Design	19,200 lbs
Combat	18,123 lbs
Maximum Takeoff	23,015 lbs
Maximum Landing	22,500 lbs

#### Dimensions:

Wing	
Area	549 sq ft
Span	60 ft
Length	43 ft 5 in
Height	16 ft 7 in
Tread	14 ft 5 in

#### Ordnance:

Bomb bay

- 1 Mk 41 Torpedo
- 1 Mk 34 Torpedo
- 1 Mk 24 Torpedo
- 1 Mk 24 Mine could be substituted for either the Mk 41 or the Mk 34 Torpedo.

4 Wing Points (inboard and mid-wing)

- Six 5-inch HPAG or HVAR Rockets.
- Four 3.5 inch aircraft rockets.
- Four Mk 54 depth bombs.
- Three AN/SSQ-1 Sonobuoys.
- Two dispensers of AN/SSQ-2 Sonobuoys and Mk 5 drift signals (nine each).

Two releasable fuel tanks, 75 or 150 gallons each.

#### Fire control:

- 1 Mk 23-6 Bombsight mounted on a Mk 41-3 periscope.
- 1 Mk 8-8 Gun sight.

Maximum bomb capacity: 3,700 lbs

#### Cameras:

- 1 AN-N6A, Gun
- 1 K-25A, Reconnaissance

AN/AVQ-2 Searchlight on starboard outboard wingpoint.

AN/APS-31 Radar on port outboard wingpoint.

Combat range 795–990 nautical miles

#### **AF-2W (Mission and Description):**

The AF-2W was the production development of the XTB3F-1S. Its mission was radar search for submarines.

After detecting an underwater craft the AF-2W would direct its companion aircraft, the AF-2S onto the target to launch an attack. The AF-2W was a four-place aircraft for operation ashore and aboard carriers. The airplane was conventional in design and structure with an all metal two-spar wing and a semi-monocoque fuselage. The landing gear, slotted flaps, wing folding mechanism, and pilot's canopy were hydraulically operated. Ailerons were of the sealed balance type with spring tabs and one trim tab. Rudder had a combination trim and 4 to 1 ratio balance tab. Elevators were interconnected, one equipped with a spring tab and the other with a trim tab. Power plant installation was conventional with steel tube mount.

Specifications for the AF-2W are as follows:

Power plant One Pratt and Whitney R-2800-48

Weight:  
 Empty 15,858 lbs  
 Basic 16,037 lbs  
 Design 19,200 lbs  
 Combat 18,629 lbs  
 Maximum takeoff 21,802 lbs  
 Maximum landing 21,500 lbs

Dimensions:  
 Wing Area 549 sq ft  
 Span 60 ft  
 Length 43 ft 5 in  
 Height 16 ft 7 in  
 Tread 14 ft 5 in

Ordnance:  
 None

Electronics:  
 VHF Communication AN/ARC-28  
 UHF Communication (Dual) AN/ARC-27  
 MHF Liaison AN/ARC-2  
 Interphone AN/AIC-4 or AN/AIC-4A  
 Homing AN/ARR-2A and AN/ARN-21

Radar Altimeter AN/APN-1 or AN/APN-22  
 Range Receiver R-23A/ARC-5  
 Radar Countermeasures AN/APR-9B and AN/APA-70C  
 Radar AN/APS-20C  
 Speed Control Kit AN/APS-20  
 Radar Receiving Set AN/APR-12  
 Radar Relay Transmitter AN/ART-26 or AN/ART-28  
 Ground Position Indicator AN/APA-57A or AN/APA-57C or AN/APA-81  
 IFF AN/APX-2 or AN/APX-2A or AN/APX-6 or AN/APX-7  
 Combat Range: 750-1,315 nautical miles

**AF-3S (Mission and Description):**

Same as the AF-2S but with MAD gear installed.

**Bureau Numbers**

XTB3F-1 90504  
 XTB3F-2S 90505  
 XTB3F-1S 90506 (XTB3F-1S canceled)  
 AF-2S 123088-123116 (Even numbers to AF-2S)  
 AF-2W 123089-123117 (Odd numbers to AF-2W)  
 AF-2W 124187-124209 (Odd numbers to AF-2W)  
 AF-2S 124188-124210 (Even numbers to AF-2S)  
 AF-2S 124778-124848 (Even numbers to AF-2S)  
 AF-2W 124779-124849 (Odd numbers to AF-2W)  
 AF-2S 126720-126737  
 AF-2W 126738-126755  
 AF-2S 126756-126821  
 AF-2W 126822-126835  
 AF-2S 129196-129242  
 AF-3S 129243-129257  
 AF-2W 129258-129299  
 AF-3S 130364-130388  
 AF-2W 130389-130404

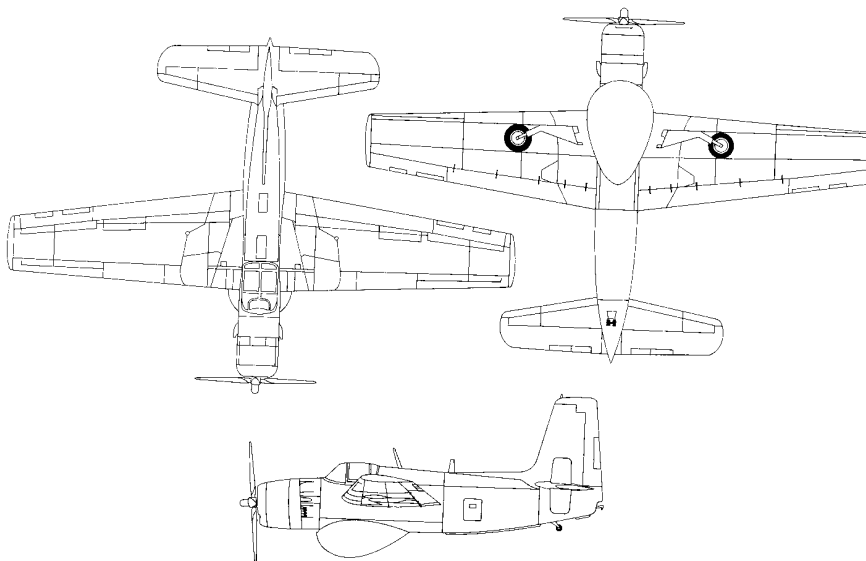

*Line drawings for an AF Guardian.*

## AJ (A-2) Savage

On 24 June 1946, the Navy awarded North American a contract to build the aircraft that would become the AJ Savage. Intended as a carrier based bomber, the AJ was first reported in squadron service by VC-5 on 13 September 1949. It was eventually redesignated A-2.

First contract	26 June 1946
First flight	3 July 1948
First reported in squadron	13 Sept 1949
Last delivery	June 1954
Last reported in squadron	An AJ-2P by VAP-62 and VCP-61 in January 1960
Number Accepted	143



*An AJ-2 Savage.*

### **Models Accepted from the Manufacturer (New Builds)**

#### **XAJ-1:**

Experimental version.

#### **AJ-1 (Redesignated A-2A):**

Crew of three in pressurized cockpit. Wing contained slotted flaps. Power boost system for ailerons, elevators, and rudder.

#### **Weights:**

Empty	27,558 lbs
Basic	27,938 lbs
Design	47,000 lbs
Combat	35,742 lbs
Maximum take off	50,954 lbs
Maximum Landing	41,300 lbs

#### **Power plant:**

Two Pratt & Whitney R-2800 44W propellers on wings.  
One Allison J-33-A-1 turbojet in tail.

#### **Dimensions:**

Wing area	836 sq ft
Wing span	71 ft 5 in
Length	63 ft 1 in
Height	20 ft 5 in

#### **Ordnance:**

Guns	None
Maximum Bomb Capacity	12,000 lbs

#### **AJ-2:**

The AJ-1 with two Pratt & Whitney R-2800-48 and one Allison J33-A-10 engine. Fuel capacity was increased over that of AJ-1.

#### **AJ-2P:**

AJ-2 aircraft with nose redesigned to accommodate cameras.

### **Bureau Numbers**

XAJ-1	121460-121462
AJ-1	122590-122601
AJ-1	124157-124186
AJ-1	124850-124864
AJ-2P	128043-128051
AJ-2P	129185-129195
AJ-2	130405-130421
AJ-2P	130422-130425
AJ-2	134035-134072
AJ-2P	134073-134075

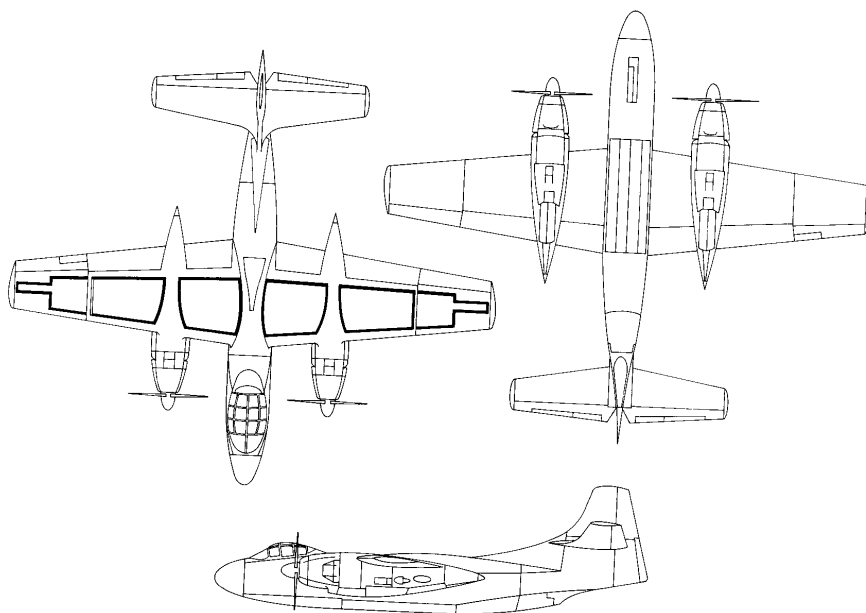

*Line drawings for an AJ Savage.*

## AM Mauler

Improvements in engines and aircraft design led the Navy to abandon its old system of using different aircraft such as SB for Scout Bomber and TB for Torpedo Bomber and to combine these missions in one aircraft. The Douglas Company's BT2D was an example of an aircraft that was to combine the bombing and torpedo launching functions in one airframe. The Martin Company's BTM was designed in the same spirit. Eventually the old system of designation reflected the

changes when the letter A for Attack replaced S (Scout), B (Bomber) and T (Torpedo). The BT2D served virtually all its life as the AD and later A-1. The BTM is remembered as the AM Mauler.

First contract	14 January 1944
First flight	26 August 1944
First reported in squadron	1 March 1948
Last delivery	October 1949
Last reported in squadron	An AM-1Q on 1 October 1950 by VC-4
Number Accepted	152



*An AM-1 Mauler in flight carrying a full load of ordnance, March 1949.*

### **Models Accepted from the Manufacturer (New Builds)**

**XBTM-1:**

Experimental model of the AM-1.

**AM-1**

Torpedo and dive bomber, also for use in scouting missions. All bombs, mines, torpedoes, rockets, etc. were carried externally on three pylons on wings and fuselage. Provision for radar on right wing pylon. One crew. Structure was conventional, all-metal. Split dive brakes interlocked with landing flaps. Capable

of carrying incendiary and fragmentation clusters and smoke tanks.

**Weight:**

Empty	15,100 lbs
Basic	15,830 lbs
Design	19,450 lbs
Combat	20,083 lbs
Maximum take off	25,000 lbs
Maximum landing	17,950 lbs on carrier. 20,600 lbs on land.

Power plant One Pratt & Whitney R-4360-4W.

Dimensions:

Wing area            496 sq ft  
 Wing span          50 ft 1 3/8 in  
 Length              41 ft 8 13/16 in  
 Height               16 ft 10 5/8 in  
 Ordnance:  
   Guns                four 20 mm (M3) with 800 rounds  
   Maximum Bomb  
     Capacity          6,000 lbs  
**AM-1Q:**  
   Equipped for radar countermeasures.

**Bureau Numbers**

XBTM-1	85161-85162
AM-1	22257-22295
AM-1Q	22296
AM-1	22297-22345
AM-1Q	22346-22355
AM-1	22356-22856
AM-1Q	122388-122393
AM-1	122394-122437

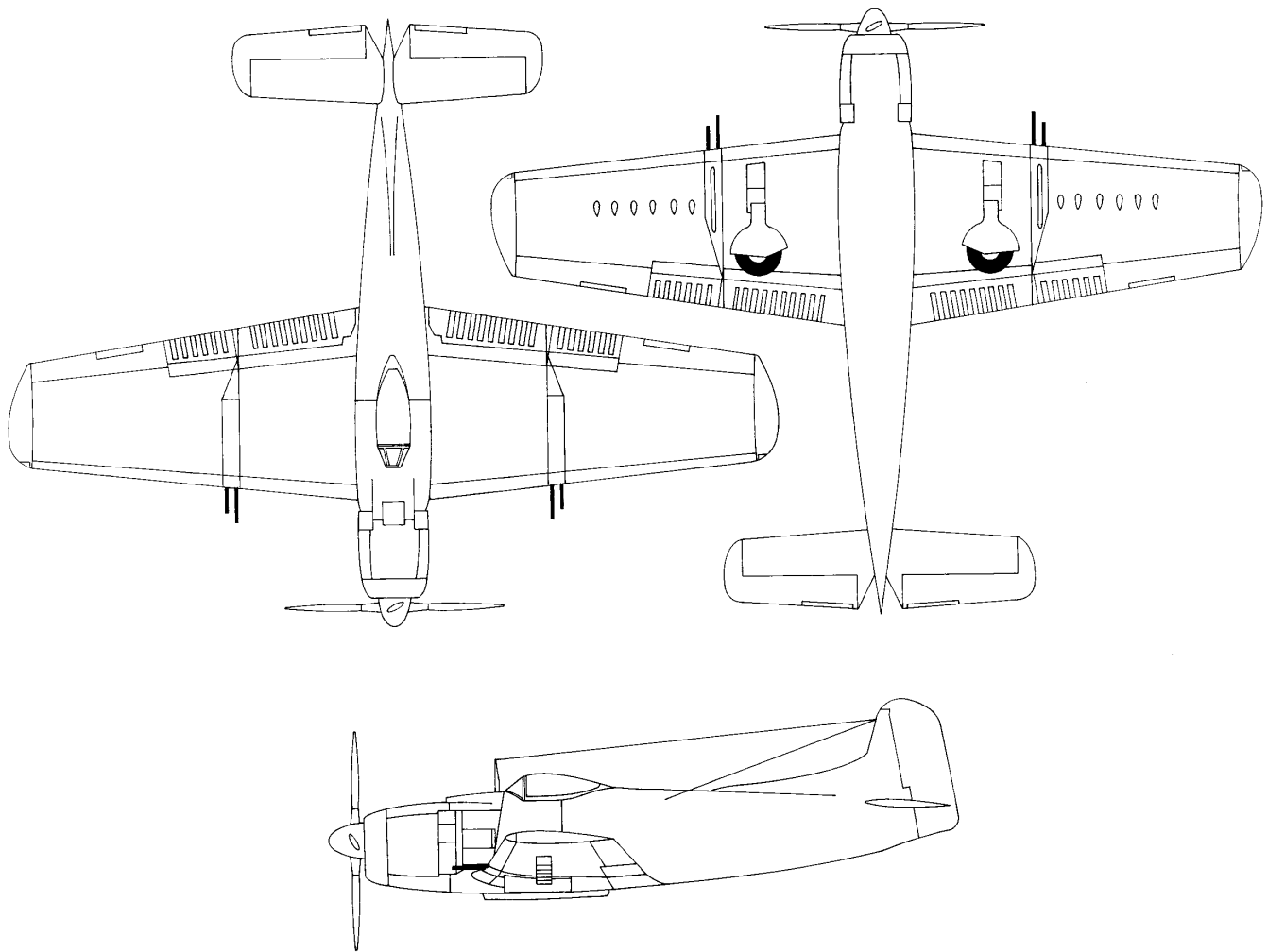

*Line drawings for an AM Mauler.*

## BG

An attack biplane capable of delivering a 1,000 pound bomb, the BG was the only aircraft that the Great Lakes Corporation designed and produced for the U.S. Navy. Other Great Lakes aircraft which the Navy used include the TG-1 and TG-2, both of which were variations of Martin's T4M. Great Lakes won the contract for the BG on 13 June 1932. The aircraft made its first flight the following summer. Eventually, the Navy accepted 61 of these planes. They remained in squadron use until June 1941.



*An XBG-1, June 1933.*

### Models Accepted

**XBG-1:**

Experimental version of the BG-1.

**BG-1:**

Crew	two
Length	28 ft 9 in
Height	11 ft
Span:	
upper	36 ft
lower	33 ft 8 in
Wing area	383.8 sq ft
Weights:	
gross	6,349 lbs

Range	550 statute miles
Engine	one Pratt & Whitney 750 hp R-1535-82
Ordnance:	
bomb	up to 1,000 lbs
guns	one .30 fixed forward firing one .30 flexible in rear cockpit

### Bureau Numbers

XBG-1	9220
XBG-1	9494-9520
BG-1	9534-9550
BG-1	9840-9855

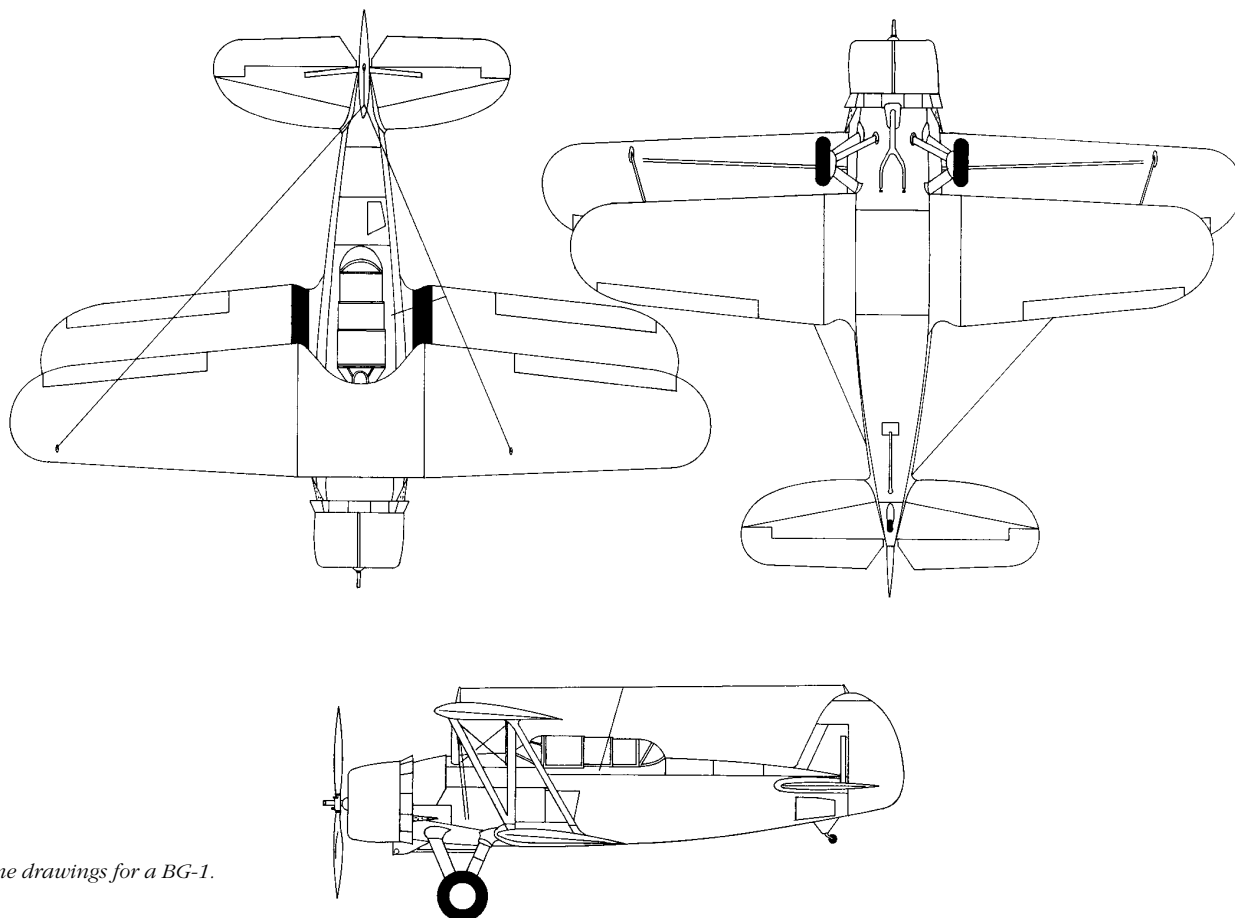

*Line drawings for a BG-1.*

## BM

On 13 June 1928 the Navy awarded the Martin Company a contract to build a biplane dive bomber that could handle a torpedo as well as a thousand pound bomb. It would be the first Navy dive bomber that could carry a payload this large. Martin built the prototype to Bureau of Aeronautics Design 77 under the designation XT5M-1. To provide costing data the Naval Aircraft Factory also built a prototype and designated it the XT2N-1. Martin's XT5M-1 first flew in the spring of 1929. The production version was designated BM-1 and was first accepted by a squadron (VT-1S) in October 1932. Besides the XT5M-1, the Navy accepted 33 BMs from Martin and the XT2N-1 from the Naval Aircraft Factory.

### **Models Accepted from the Manufacturer (New Builds)**

#### **XT5M-1:**

Prototype of the BM-1.

#### **XBM-1:**

Built by Martin for use by the National Advisory Committee for Aeronautics (NACA). This aircraft was not an experimental version of the BM in the usual sense; its X indicated that it would be used experimentally by NACA.

#### **BM-1:**

Crew	Two
Length	28 ft 4 in
Height	12 ft 3 in
Span:	
upper	41 ft
lower	40 ft
Wing area	435.8 sq. ft
Weights:	
gross	6,183 lbs
useful	2,559 lbs



*A BM-1.*

Range	415 nautical miles
Engine	One 600 hp Pratt & Whitney R-1690-44
Ordnance:	
bomb	one 1,000 pounder
guns	one .30 fixed synchronized mounted within the fuselage to the right of the centerline. one .30 flexible gun in rear cockpit.

#### **BM-2:**

Modified version of BM-1. Very small differences.

#### **XT2N-1:**

Prototype manufactured by the Naval Aircraft Factory.

### **Bureau Numbers**

XT2N-1	A8052
XT5M-1	A8051
XBM-1	9212
BM-1	A8879-A8890
BM-1	9214-9217
BM-2	A9170-A9185

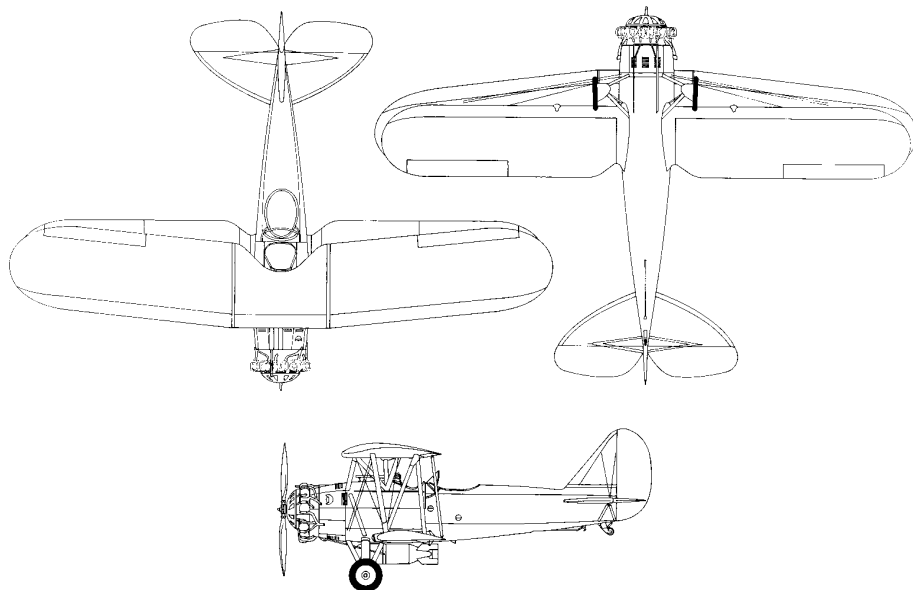

*Line drawings for a BM.*

## BT

Designed by John Northrop, this aircraft conformed to his practice of using all-metal structures with progressive aerodynamic features. The Navy awarded Northrop a contract to produce this attack plane in November 1934 and designated it BT, the T being Northrop's manufacturer's letter. After his company became a division of the Douglas Corporation in 1937, Douglas used the XBT-2 as a prototype for the aircraft that became the SBD Dauntless.



*An XBT-1 coming in for a landing, circa mid-1930s.*

### *Models Accepted from the Manufacturer (New Builds)*

**XBT-1:**

Experimental version of the BT-1.

**BT-1:**

Crew	two
Length	31 ft 8 in
Height	13 ft
Span	41 ft 6 in
Wing area	315 sq ft
Weights:	
gross	6,978 lbs
useful	2,511 lbs
Range	546 statute miles
Engine	one 825 hp Pratt & Whitney R-1535-94
Ordnance:	
bomb	one 1,000 pound
guns	one .50 fixed, forward firing one .30 flexible, dorsal

**XBT-2:**

Slightly modified version of the BT-1. The XBT-2 served as a prototype for the SBD Dauntless.

### **Bureau Numbers**

XBT-1	9745
BT-1	0590-0626
BT-1	0628-0643
XBT-2	0627

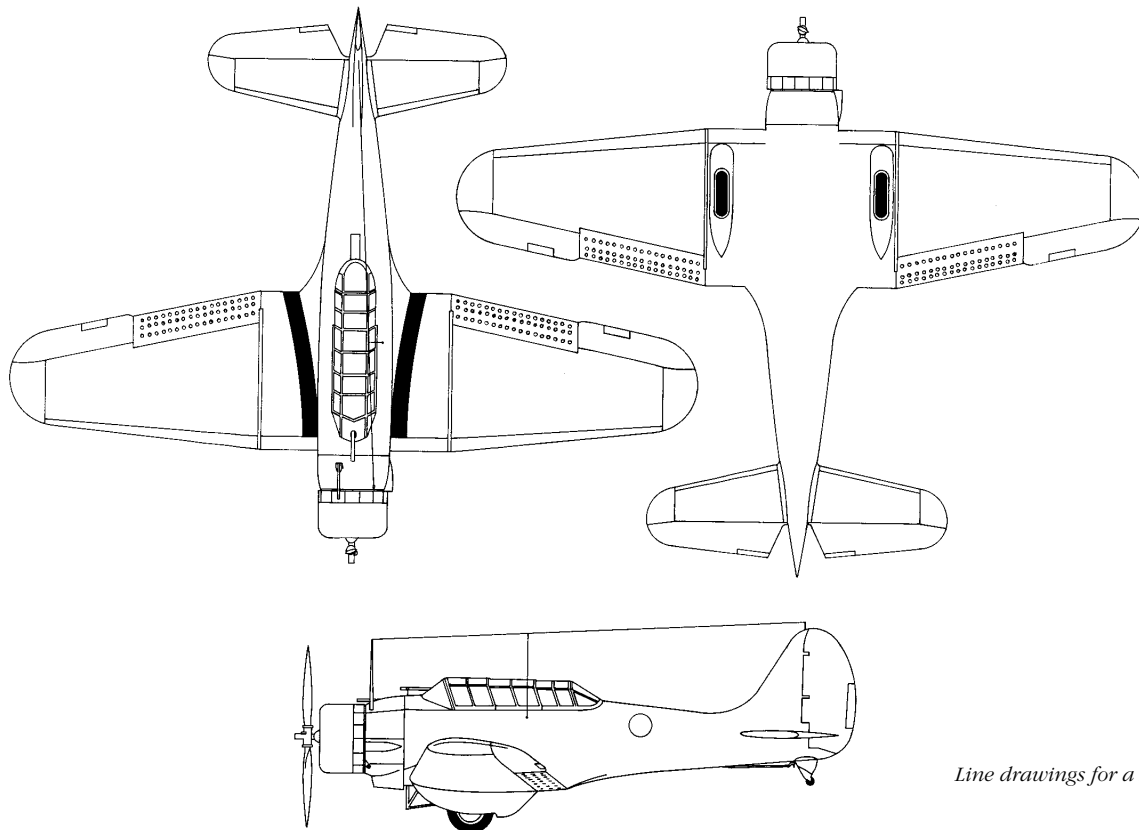

*Line drawings for a BT.*



## CS and SC

In one of those unusual developments that stands out in the history of military procurement this aircraft has a story to tell. The Curtiss Company designed and built the CS torpedo bomber as a large biplane that could be equipped with floats or landing gear and powered by an in-line engine. The Navy gave Curtiss the development contract for this aircraft in June 1922; Curtiss delivered the first articles in early 1924. In the subsequent competition for the production contract, Martin underbid Curtiss and produced the aircraft as the SC.

Curtiss built a total of 6 CS-1 and 2 CS-2 aircraft. The CS-2 had provision for a third float and was powered by a Wright T-3 engine where the CS-1 was powered by a Wright T-2. The CS-2 has some success in setting distance, duration, and speed records.

Martin built 35 SC-1s and 40 SC-2s. The SC was first reported in squadron in January 1924. It was last reported by VT-2 on 19 December 1927. The specifications of the SC are as follows:

Span	56 ft (SC-2 had folding wings that folded along the fuselage)
Length	34 ft
Wing Area	852 sq ft
Gross Weight	9,100 lbs for the SC-1 9,433 lbs for the SC-2



A CS-2, circa mid-1920s.

Empty Weight	5,685 lbs for the SC-1 6,019 lbs for the SC-2
Engine	Wright T-3 engine
Maximum bomb load	1,600 lbs

### Bureau Numbers

CS-1	A6500-A6505
CS-2	A6731-A6732
SC-1	A6801-A6835
SC-2	A6928-A6967

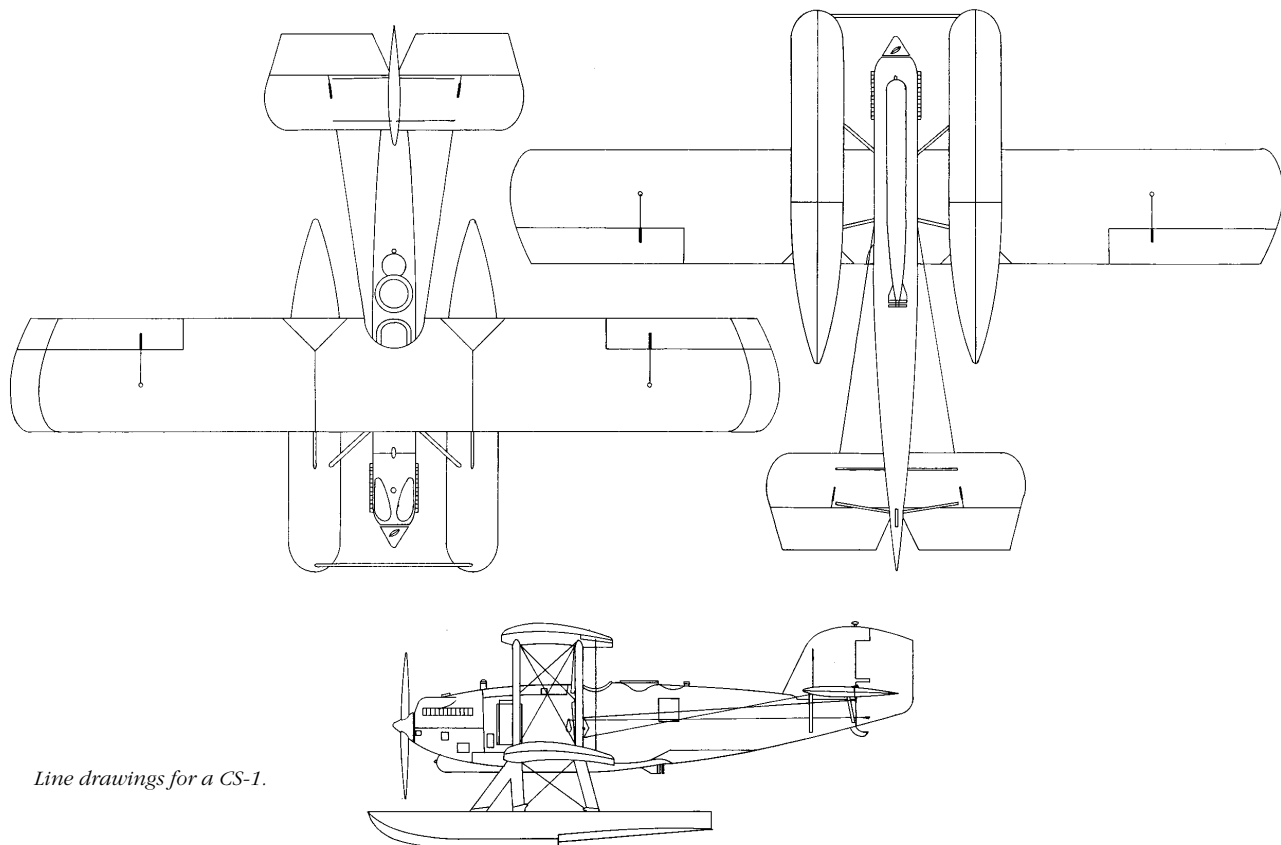

Line drawings for a CS-1.

## DT-2

In 1921 the Navy Department ordered a torpedo bomber from the Douglas Aircraft Company. Douglas was a new company at the time and had yet to produce an aircraft for either the Navy or the Army. The company's owner, Donald W. Douglas, Sr., personally designed the aircraft that would fill the Navy's order. Powered by a 400 horsepower Liberty, the DT-1 had folding wings. It made its first flight in November 1921. Although there were three aircraft on the Navy's original order only one was accepted with the designation DT-1, the other two, and all subsequent, were accepted as DT-2.

Eventually this aircraft was supplied to the Navy by four sources. Douglas built 41, the Naval Aircraft Factory built 6 under the designations DT-2 and DT-4, Dayton Wright built 11 DT-2s, and LWF (Lowe, Willard, and Fowler) built 20 DT-2s. The aircraft was first delivered to squadron on 12 December 1922. It was last reported in squadron by VF-6B on 1 April 1928.



*The first DT built by Douglas, December 1924.*

### **Models Accepted from the Manufacturer (New Builds)**

**DT-1:**

Initial designation of the DT-2. Crew of one.

**DT-2:**

Specifications for the seaplane configuration are given below. Some of the landplane's dimensions were slightly different.

Crew	2, aviator and observer
Engine	one Liberty, 400 hp.
Length	37 ft 8 in
Weights:	
full load	7,291 lbs
useful	2,765 lbs
Armament	one 1,835 pound torpedo fixed guns and 2,350 rounds
Range	about 234 nautical miles
Height	15 ft 1 in
Length	37 ft 8 in
Span	50 ft
Wing area	707 sq ft

### **Other Designations**

**DT-4:**

Same as DT-2 but powered by the Wright T-2, 525 hp engine. The DT-4 was a modification of the DT-2 by the Naval Aircraft Factory.

### **Bureau Numbers**

DT	A6031-A6033
DT-2	A6085-A6095 (Dayton-Wright)
DT-2	A6405-A6422 (Douglas)
DT-2	A6423-A6428 (Naval Aircraft Factory)
DT-2	A6563-A6582 (Douglas)
DT-2	A6583-A6602 (LWF)

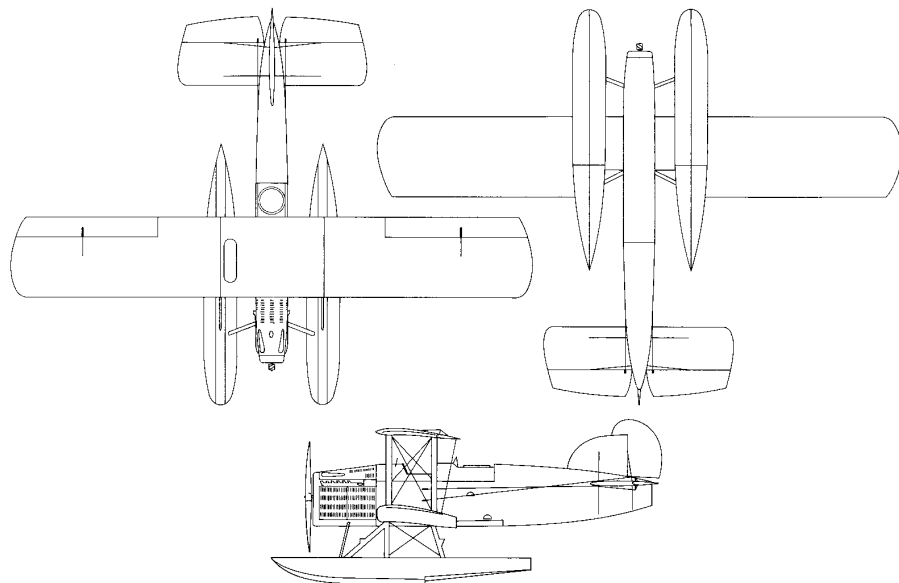

*Line drawings for DT-2.*

## F-4 Phantom II

The F-4 began life as an unsolicited proposal from the McDonnell Aircraft Company to the Navy's Bureau of Aeronautics in 1953. McDonnell envisioned a twin-engine strike/fighter, and the aircraft's initial designation was AH-1, but the Navy soon made changes in the specification to require a high-altitude, long range fighter with the designation F4H-1. The name Phantom II was chosen to declare the aircraft's lineage from McDonnell's FD-1 Phantom which was the first all-jet aircraft the Navy operated. The Phantom II first flew on 27 May 1958 and was first reported in squadron, VF-121, in December 1960. It would prove to be one of the finest aircraft ever operated by the Navy and Marine Corps. Before the last delivery was made in December 1971, the Navy accepted 4,261 Phantom IIs, 3,057 of which were for foreign military sales attesting to the aircraft's international success. It was redesignated F-4 in 1962.

### ***Model Designations Accepted From the Manufacturer (New Builds)***

#### **F4H-1F (F-4A):**

Two-place, twin-engine, tricycle gear, carrier-based, all-weather fighter carrying missiles and special stores.

#### **F4H-1 (F-4B):**

Modification of the F-4A with the J79-GE-8 engine.

Specifications for the F4H-1 (F-4B) are as follows:

Crew	Two
Power Plant	Two General Electric J79-8
Range	Maximum Combat 1,606 nautical miles
Weight	
Empty	27,424 lbs
Basic	27,694 lbs
Design	34,500 lbs
Combat	38,018 lbs
Maximum Take-off	56,000 lbs
Maximum Landing	34,000 lbs arrested
Dimensions	
Wing	
Area	530 sq ft
Span	38.4 ft
Length	58.2 ft
Height	16.3 ft
Tread	17.9 ft
Ordnance	AIM-7 Sparrow and AIM-9 Sidewinder missiles

#### **F4H-1P (RF-4B):**

F-4B equipped for photography.

#### **F-4J:**

Similar to F-4B equipped with the AWG-10 pulse doppler radar and improved avionics.



*An F4H-1 Phantom II in flight, circa late 1950s.*

**Other Designations**

- TF-4A:**  
Trainer version. Not carrier deployable
- QF-4B:**  
Modified as a drone or control plane. Suitable for operational use.
- F-4G:**  
F-4B aircraft equipped with two-way tactical digital data communications set (AN/ASW-21) for all nonautonomous modes of flight including automatic vectoring, automatic traffic control and automatic carrier landing.
- YF-4J:**  
Similar to F-4B but equipped with Pulse Doppler Radar.
- RF-4J:**  
Similar to RF-4C but with improved engine. Navy use.
- F-4N:**  
Extensive redesign of F-4B.
- F-4S:**  
F-4J modified for extended service life.

**U.S. Air Force Use**

- |       |       |
|-------|-------|
| F-4C  | EF-4C |
| RF-4C | F-4D  |
| EF-4D | F-4E  |
| RF-4E | YF-4E |
| F-4F  | TF-4F |

**Foreign Military Use**

- |      |      |
|------|------|
| F-4K | F-4M |
|------|------|

**Bureau Numbers**

- |                |   |
|----------------|---|
| F4H-1F (F-4A)  | 143388-143392, 145307-145317, 146817-146821, 148252-148275  |
| F4H-1 (F-4B)   | 142259-142260, 148363-148434, 149403-149474, 150406-150493, 150624-150653, 150993-151021, 151397-151519, 152207-152331, 152965-153070, 153912-153950 (canceled) |
| F4H-1P (RF-4B) | 151975-151983, 153089-153115, 157342-157351   |
| F-4J           | 153071-153088, 153768-153911, 154781-154788, 155404-155580, 155731-155916, 155904-155916 (canceled), 157242-157309, 158346-158379                               |

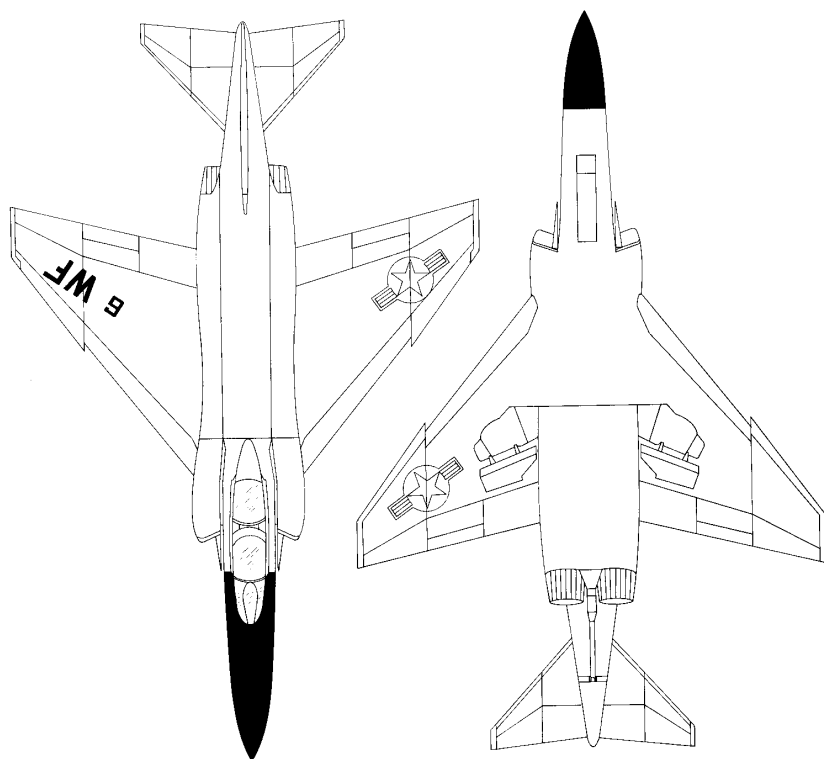

*Line drawings for the F-4.*

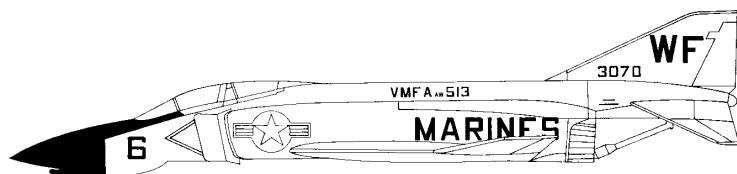

## F-5 (T-38) Talon

On 7 October 1969, the U.S. Navy took delivery of its first Northrop T-38 Talon supersonic trainer. This was the first of five that the Navy had ordered for the U.S. Naval Test Pilot School at Patuxent River, Maryland. The aircraft had been in use by the Air Force since 1961. From the development work that produced the T-38 design, Northrop developed the F-5 Tiger II for the Air Force. In 1974, the Navy began using the F-5E Tiger II at the Navy Fighter Weapons School as an adversary aircraft.



*An F-5E Tiger II in flight.*

### **Model Designations Accepted from the Manufacturer (New Builds)**

**F-5E:**

Initial version of the Tiger II used by the Navy. The following are characteristics of the F-5E:

Crew	One
Power Plant	Two 5,000-lb General Electric J85-GE-21 turbojets

**Weight**

Maximum Takeoff	24,664 lbs
Empty	9,683 lbs

**Dimensions**

Wing Span	6 ft 8 in
Wing Area	186 sq ft
Length	48 ft
Height	13 ft 3 in

**F-5F:**

Upgraded F-5E. Two-place fighter/trainer.

### **Bureau Numbers**

F-5E	159878-159882, 160792-160796, 162307
F-5F	160964-160966

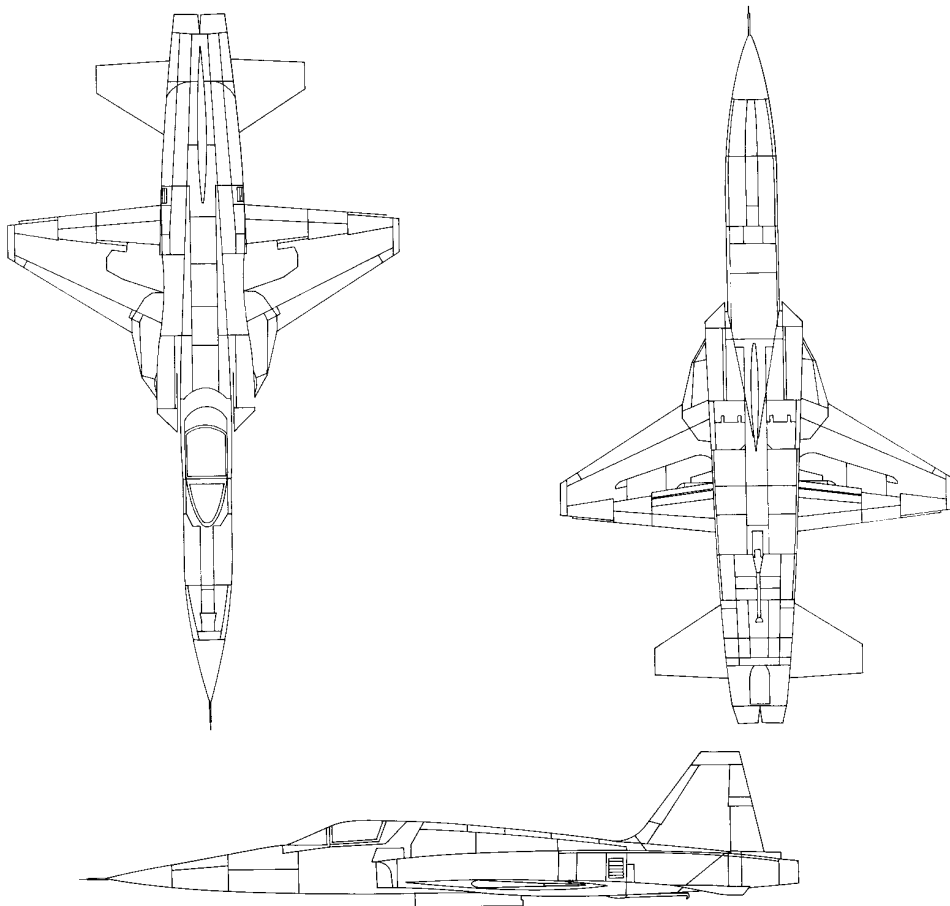

*Line drawings for the F-5.*

## F2H (F-2) Banshee

Beginning its life as the XF2D-1, the Banshee was the last of McDonnell's aircraft to bear the company's original Navy designation letter "D". This change was made by Navy Aircraft Circular Letter 81-47 of 28 August 1947. The immediate successor to McDonnell's FD-1 Phantom, the Banshee bore a great resemblance to the Phantom but was larger. The Navy placed the first contract for this all jet, carrier-based fighter on 2 March 1945. The first flight occurred 11 January 1947. It was first delivered to VF-171 in March 1949 and its last squadron employment was reported by VAW-11 on 30 September 1959. A total of 894 Banshees were procured.



An F2H-3 at the McDonnell Aircraft Company.

### Models Accepted from the Manufacturer (New Builds)

#### XF2H-1:

Experimental version of the F2H-1.

#### F2H-1:

Powered by two Westinghouse J34-22A/30 engines, 3,150 lbs at takeoff .

#### F2H-2:

Longer fuselage than the F2H-1, capacity to carry external fuel tanks on wing tips, and powered by two J34-34 engines. Specifications for the F2H-2 are as follows:

Crew	one
Engine	2 Westinghouse 3,250 lbs takeoff J34-34
Weights:	
empty	10,321 lbs
combat	15,540-17,742 lbs
Armament:	
bombs	1,540 lbs maximum
guns	four 20 mm nose (M3)
Combat range	755-1,280 nautical miles
Height	14 ft 6 in

Length	42 ft 1 in
Wing span	44 ft 10 in
Wing area	294 sq ft

#### F2H-2N:

F2H-2 configured for night operations.

#### F2H-2P:

F2H-2 configured for photographic reconnaissance.

#### F2H-3 (Became F-2C):

Basically the F2H-2 adapted to all-weather operations.

#### F2H-4 (Became F-2D):

The F2H-3 with improved radar equipment.

### Bureau Numbers

XF2H-1	99858-99860
F2H-1	122530-122559
F2H-1	122990-123015
F2H-2	123204-123299
F2H-2N	123300-123396
F2H-2	123314-123396 (123383-123396 canceled)
F2H-2	124940-125071
F2H-2P	125072-125079
F2H-2	125500-125505
F2H-2	125649-125679
F2H-2P	125680-125706
F2H-3	126291-126350
F2H-4	126351-126353
F2H-3	126354-126489
F2H-2P	126673-126695
F2H-3	127493-127546
F2H-4	127547-127693
F2H-3P	127694-127695 (all canceled)
F2H-3	128745-128856 (all canceled)
F2H-2	128857-128886
F2H-3/3P	129050-129132 (all canceled)

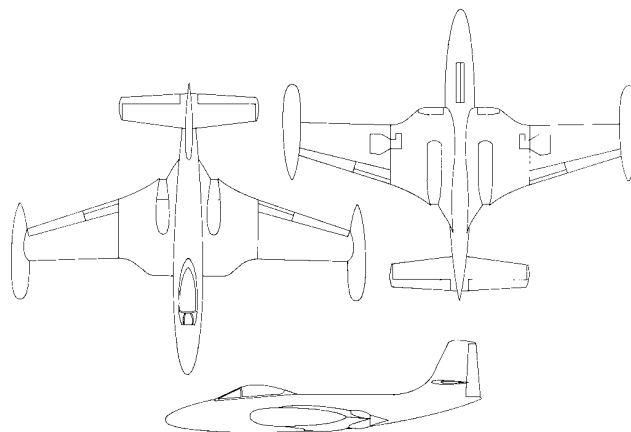

Line drawings for the F2H.

## F3D (F-10) Skyknight

In April 1946, the U.S. Navy awarded the Douglas Company a contract to produce the first carrier-based, all-weather, jet-powered night interceptor. The aircraft first flew March 1948 and was delivered to its first squadron, VC-3, in February 1951. The last delivery was in October 1953. A total of 268 aircraft were accepted. It was last reported in squadron in May 1970. The aircraft's designation was changed to F-10 in 1962. The production versions F3D-1 and F3D-2 both deployed. Plans for an F3D-3 never materialized and no aircraft by that designation was ever accepted.

### **Model Designations Accepted from the Manufacturer (New Builds)**

#### **XF3D-1:**

Experimental variant of the Skyknight. Three articles were built.

#### **F3D-1 (F-10A):**

Twenty-eight F3D-1s were eventually procured. The F3D-1 designation was changed to F-10A in 1962. Characteristics of the F3D-1 are as follows:

Crew	Two
Power Plant	Two 3,000-lb Westinghouse J34-WE-38
Combat Radius	675 nautical miles
Weight	
Gross	22,609 lbs
Dimensions	
Wing	
Area	401 sq ft
Span	50 ft
Length	45 ft 5 in
Height	16 ft 1 in
Ordnance	Four 20-mm nose guns with 800 rounds.

#### **F3D-2 (F-10B):**

This second variant of the Skyknight used the 3,400 lb Westinghouse J34-WE-36 engine. A total of 237 were procured. This designation was changed to F-10B in 1962.

### **Other Designations:**

#### **F3D-1M and -2M (MF-10B):**

F3D-1 and F3D-2 equipped with radar and provisions for launching missiles. The F3D-2M designation was changed to MF-10B in 1962. The F3D-1 was no longer in service in 1962.

#### **F3D-2Q (EF-10B):**

F3D-2 modified for electronic warfare. One of the



*An XF3D-1 at NAS Patuxent River, Maryland, circa 1950.*

earliest tactical jet aircraft modified for the Electronic Warfare role. The designation was changed to EF-10B in 1962.

#### **F3D-2T:**

F3D-2 converted to serve as a radar trainer. The designation was no longer in service in 1962.

#### **F3D-2T2 (TF-10B):**

F3D-2T equipped with AN/APG-51 radar. The designation was changed to TF-10B in 1962.

### **Bureau Numbers**

XF3D-1	121457-121459
F3D-1	123741-123770
F3D-2	124595-124664
	125783-125882
	127019-127085
F3D-3	125883-125892 all canceled

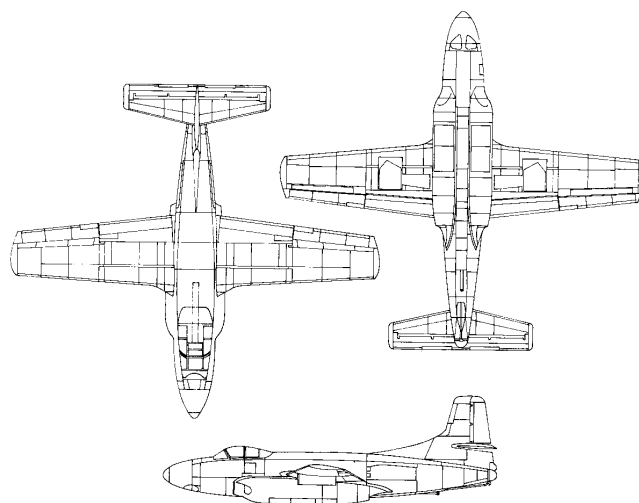

*Line drawings for the F3D.*

## F3H (F-3) Demon

In 1949, the Navy awarded the McDonnell Company a contract to produce a carrier-based, jet-powered, all-weather interceptor designed as a successor to the F2H Banshee and incorporating the latest technology addressing the questions about jet-powered carrier-based tactical planes. The Demon would become one of the earliest Navy fighters to deploy with air-to-air missiles and the only single-engine fighter McDonnell ever built for the Navy. The Demon made its initial flight in August 1951. The first delivery was to VF-14 on 7 March 1956. The F3H fought a long and ultimately unsuccessful battle with its power plant; while the aircraft has its place in naval aviation history, it never fully met expectations. The last delivery occurred in November 1959. A total of 519 articles were accepted and it was last reported in squadron by VF-161 in August 1964. The F3H was redesignated the F-3 in 1962.

### *Model Designations Accepted from the Manufacturer (New Builds)*

#### **XF3H-1:**

The experimental version of the Demon. Two articles were accepted by the Navy. It was initially intended to be powered by the Westinghouse J40-WE-8 engine, which soon changed to the J40-WE-10, but production problems with the -10 engine led to one of the XF3Hs being powered by the Westinghouse J40-6. The production problems resulted in a decision to use the Allison J71-A-2 as a back-up engine. The production version of the Westinghouse J40-WE-8 was designated -22 and it was this engine that would power the initial production F3H-1s, while the Allison J71-A-2 powered the later articles.

#### **F3H-1:**

First production version of the Demon. The F3H-1 designation was never changed since the -1 was no longer in service at the time of the redesignation in 1962.



*An XF3H-1 Demon taking off on a routine test flight, May 1953.*



**F3H-1N:**

All-weather version of the F3H-1.

**F3H-2 (F-3B):**

Production version. Powered by Allison J71-A-2 engine. Redesignated F-3B in 1962.

**F3H-2M (MF-3B):**

The F3H-2M was equipped to launch four Sparrow or Sidewinder missiles. The aircraft was redesignated MF-3B in 1962. Its characteristics were as follows:

Crew	One
Power Plant	One 14,400 lb Allison J71-A-2B engine
Combat Radius	302 nautical miles
Weight	
Maximum Takeoff	39,000 lbs
Basic	22,028 lbs
Empty	21,292 lbs
Dimensions	
Wing	
Area	519 sq ft
Span	35 ft 4 in
Length	58 ft 11.5 in
Height	14 ft 6.6 in

**Ordnance**

Four Sparrow or Sidewinder missiles; four 20-mm fixed forward-firing guns with 600 rounds.

**F3H-2N (F-3C):**

All-weather version of the F3H-2. Also improved fire control. Redesignated F-3C in 1962.

**Other Designations**

**F3H-1P and -2P:**

Equipped for reconnaissance.

**Bureau Numbers**

F3H-1	133389-133488 canceled, 137096-137131 canceled, 137156-137215, 137859-137886 canceled, 138660-138819 canceled
F3H-1N	133489-133554
F3H-2	146328-146339, 143403-143492, 146741-146816 canceled, 143403-143492, 145202-145306
F3H-2M	133569, 133623-133638, 137033-137095
F3H-2N	133545-133568, 133570-133622, 136966-137032
F3H-2P	137132-137155 canceled

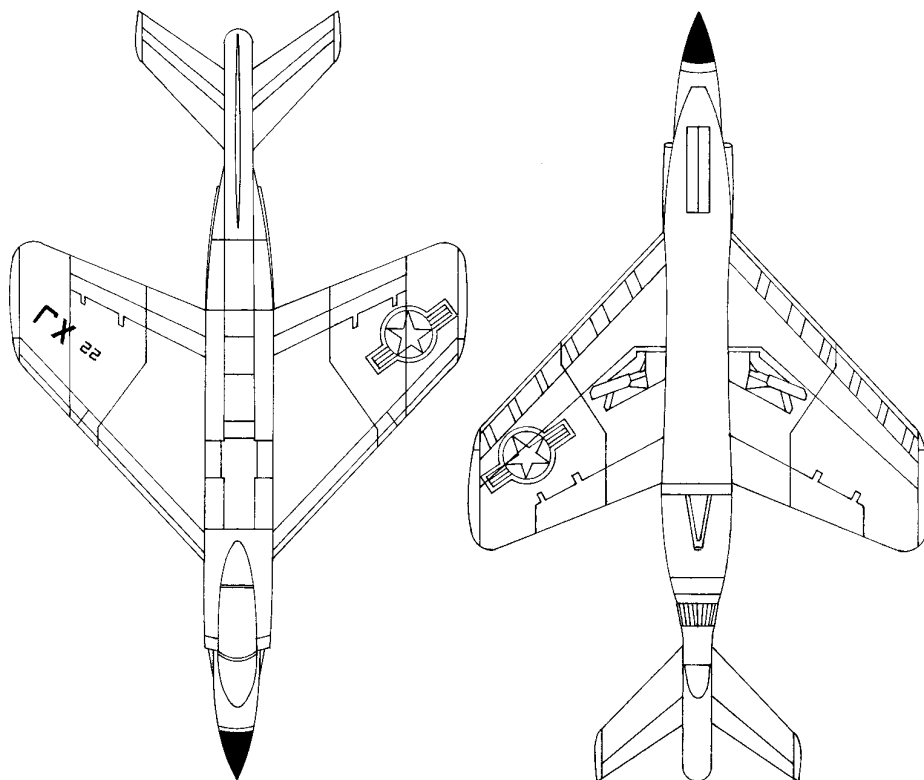

*Line drawings for an F3H.*

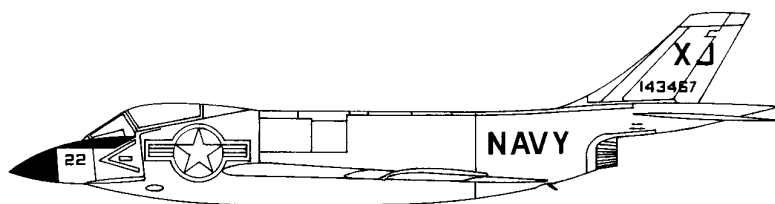

## F4D (F-6) Skyray

The Navy's need for a carrier-based, short-range fighter led to a contract award in December 1948 to Douglas for the aircraft design that became the F4D Skyray. To meet the requirement for a high rate of climb, Douglas designers came up with a swept-back modified delta wing on a tailless airframe. The F4D first flew in January 1951, but due to delays and delivery of the power plant initially intended, Composite Squadron THREE (VC-3) did not accept the first Skyray until April 1956. It was last reported in squadron by Marine Fighter Squadron ONE ONE FIVE (VMF-115) in February 1964. The F4D-1 was redesignated F-6A in 1962. A total of 421 Skyrays were accepted.



*An XF4D-1 Skyray landing aboard Coral Sea (CVA 43), October 1953.*

### **Model Designations Accepted from the Manufacturer (New Builds)**

**XF4D-1:**

Experimental version of the F4D-1.

**F4D-1:**

Crew	One
Power Plant	One Pratt & Whitney 8,000 lb J57-P-2
Combat Radius	200 nautical miles
Weight	
Maximum Takeoff	23,050 lbs from catapult
Basic	15,450 lbs
Empty	15,225 lbs

**Dimensions**

Wing	
Area	557 sq ft
Span	33 ft 6 in
Length	58 ft 11.5 in
Height	13 ft
Ordnance:	Wing provisions for rockets. Four 20 mm fixed forward-firing guns with 280 rounds.

**Bureau Numbers**

XF4D-1	124586-124587
F4D-1	134744-134973, 130740-130751, 139030-139207, 136163-136392 all canceled

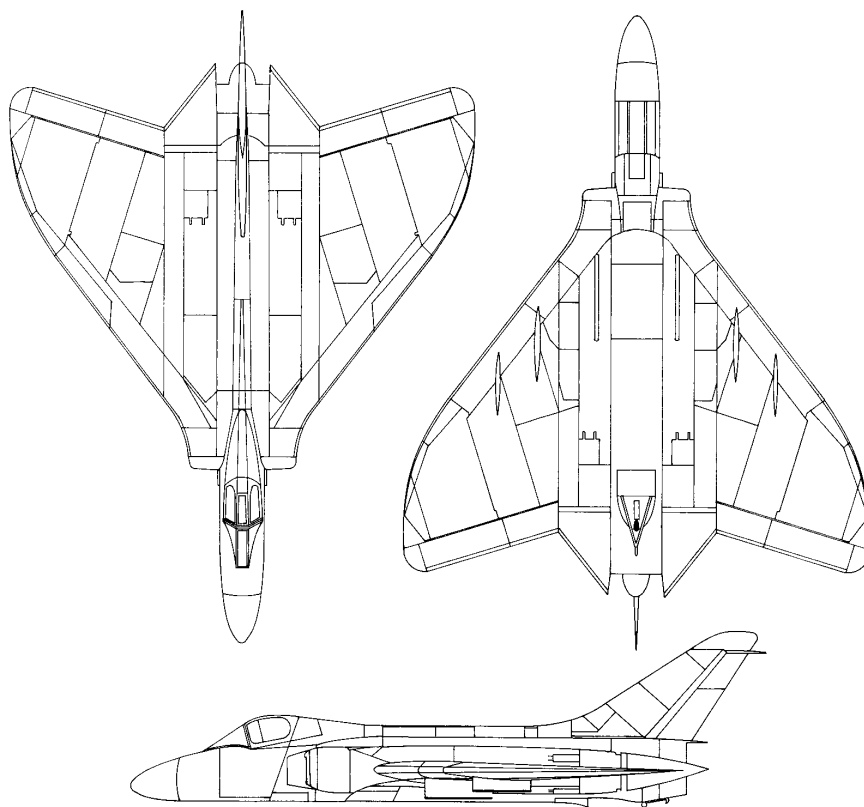

*Line drawings for the F4D-1.*

## F4U/FG/F3A Corsair

The Navy awarded a contract to the Vought Company on 30 June 1938 to produce a new single-seat, carrier-based fighter aircraft. The contract had resulted from a requirement the Navy had released to industry earlier that year. Vought engineers responded with a design that has become legendary because of its propeller of unusually large diameter and inverted gull wings which kept the main landing gear short and retractable straight back, but the fuselage stayed high enough to compensate for the large blades driven by the Pratt & Whitney R-2800 Double Wasp, the first 2,000 horsepower engine ever to power a Navy fighter aircraft. The Navy designated the airplane F4U.

The XF4U-1 made its initial flight on 29 May 1940. The first squadron delivery of the Corsair occurred on 3 October 1942 when VF-12 accepted an F4U-1. The Navy accepted the last delivery of a Corsair in January 1953.

Because production orders were so heavy during the Second World War, the Navy gave production contracts to Goodyear, who built the Corsair under the designations FG-1 and FG-1D, and to Brewster who built the aircraft as the F3A-1. Vought built 7,829 Corsairs, of which 1,067 were for foreign use; Goodyear built 4,006, of which 989 were for foreign use; and Brewster built 735, of which 430 were for foreign use. A modified version designed to fulfill a strike role was furnished by Vought under the designation AU-1.

### *Models Accepted from Vought (New Builds)*

#### **XF4U-1:**

Experimental version of the F4U-1.

#### **F4U-1:**

Specifications for the F4U-1 are as follows:

Crew	one
Engine	one R-2800-8 or -8W



*An F4U-1D Corsair.*

Propeller	Hamilton Standard, constant speed, three-bladed hydromatic; 13 ft 3 in
Wing span	40 ft 11 in
Length	33 ft 4 in
Height	18 ft 3 in
Wing area	314 sq ft
Weights:	
empty	8,873 lbs
gross	13,090 lbs
Armament	six 50 calibre fixed guns and 2,350 rounds
Combat radius	about 365 nautical miles

#### **F4U-1B:**

F4U-1 for the United Kingdom.

#### **F4U-1C:**

Same as F4U-1 but equipped with four 20 mm guns and 924 rounds. Later redesignated F4U-1B.

#### **F4U-1D:**

Same as F4U-1 but equipped with wing points for carrying releasable tanks, bombs, or rockets.

#### **F4U-4:**

Same as F4U-1D but powered by Pratt & Whitney R-2800-18W engine. Also, an improved cockpit arrangement.

#### **F4U-4B:**

Same as the F4U-4 for the United Kingdom

#### **F4U-4C:**

Same as F4U-4 but with four 20 mm guns and 924 rounds. Later redesignated F4U-4B.

#### **F4U-4P:**

F4U-4 equipped for photography.

#### **F4U-5:**

Same as F4U-4 except for 2-stage engine (Pratt & Whitney R-2800-32W).

#### **F4U-5N:**

Same as F4U-5 but equipped for night fighting.

#### **F4U-5P:**

Same as F4U-5 but equipped for photography.

#### **F4U-7:**

The end of the Corsair production line. The F4U-7 was similar to the AU-1 except for being powered by the Pratt & Whitney R-2800-18W engine. These aircraft were built for France under the Military Assistance Plan.

#### **AU-1:**

F4U-5 but equipped to fulfill a ground support attack role, this version was powered by the Pratt & Whitney R-2800-833WA engine. Armament included four 20 mm guns with 924 rounds. Maximum bomb

capacity was 8,200 pounds. There was a new instrument panel, relocated oil coolers, and additional armor over the F4U-5.

**Models Accepted from Goodyear (New Builds)**

**FG-1:**

F4U-1 built by Goodyear.

**FG-1B:**

F4U-1B built by Goodyear for the United Kingdom.

**FG-1A:**

F4U-1A built by Goodyear.

**FG-1D:**

F4U-1D built by Goodyear.

**Models Accepted from Brewster (New Builds)**

**F3A-1:**

F4U-1 built by Brewster.

**Other Designations**

**F4U-5NL:**

F4U-5N equipped for cold weather operations.

**FG-1E:**

FG-1D equipped with special radar.

**FG-3:**

Development of FG-1D with two-stage turbo-supercharged engine.

**FG-4:**

Same as F4U-4.

**F2G-1:**

Similar to FG-1 except engine and rearrangement of cockpit and cowling.

**F2G-2:**

Carrier version of the F2G-1 with folding wings, and provisions for launching and recovery.

**F3A-1D:**

Same as F4U-1D.

**Bureau Numbers**

F4U-1	02153-02156
XF4U-1	1443
F4U-1	02158-02736
F4U-1	03802-03841
F4U-1	17392-17455
F4U-1A	17456-17515
XF4U-3	17516
F4U-1A	17517-18121
F4U-1	18122-18191
F4U-1	49660-49762
XF4U-4	49763

F4U-1	49764-50300
XF4U-4	50301
F4U- 1	50302-50359
F4U-1D	50360-50659
F4U-1	55784-56483
F4U-1D	57084-57656
F4U-1C	57657-57659
F4U-1D	57660-57776
F4U-1C	57777-57791
F4U-1D	57792-57965
F4U-1C	57966-57983
F4U-1B	62915-62929
F4U-4P	62930
F4U-4B	62931-62949
F4U-4P	62950
F4U-4B	62951-62969
F4U-4P	62970
F4U-4B	62971-62989
F4U-4P	62990
F4U-4B	62991-63009
F4U-4P	63010
F4U-4B	63011-63029
F4U-4P	63030
F4U-4B	63031-63049
F4U-4P	63050
F4U-4B	63051-63069
F4U-4P	63070
F4U-4B/P	63071-63914 (63072-63914 canceled)
XF4U-4	80759-80763
F4U-4	80764-82177
F4U-1C	82178-82189
F4U-1D	82190-82259
F4U-1C	82260-82289
F4U-1D	82290-82369
F4U-1C	82370-82394
F4U-1D	82395-82434
F4U-1C	82435-82459
F4U-1D	82460-82539
F4U-1C	82540-82582
F4U-1D	82583-82632
F4U-1C	82633-82639
F4U-1C	82740-82761
F4U-1D	82762-82854 (82853-82854 canceled)
F4U-4	96752-97295
XF4U-5	97296
F4U-4	97297-97363
XF4U-5	97364
F4U-4	97365-97414
XF4U-5	97415
F4U-4	97416-97531
F4U-4	105176-106875 (105176-106875 canceled)
F4U-4	114529-115728 (114529-115728 canceled)
F4U-5	121793-121803
F4U-5P	121804
F4U-5	121805-121815
F4U-5N	121816
F4U-5	121817-121831

F4U-5N	121832-121833	F4U-5P	122167-122206
F4U-5	121834-121851	F4U-5N/NL	123144-123203
F4U-5N	121852-121853	F4U-5N	124441-124503
F4U-5	121854-121871	F4U-5NL	124504-124522
F4U-5N	121872-121874	F4U-5	124523
F4U-5	121875-121890	F4U-5NL	124524-124560
F4U-5N	121891-121893	F4U-5NL	124666-124709
F4U-5	121894-121911	F4U-5N	124710-124724
F4U-5N	121912-121915	F4U-7	133652-133731
F4U-5	121916-121931	F4U-7	133819-133832
F4U-5N	121932-121925	XAU-1	124665
F4U-5P	121936	AU-1	129318-129417
F4U-5	121937-121951	AU-1	133833-133843
F4U-5N	121952-121955	XF2G-1	12992
F4U-5P	121956-121957	FG-1D	12993-13470
F4U-5	121958-121972	XF2G-1	13471-13472
F4U-5N	121973-121976	FG-1D	13473-14690
F4U-5P	121977-121978	XF2G-1	14691-14695
F4U-5	121979-121994	FG-1D	14696-14991
F4U-5N	121995-121998	FG-1D	67055-67254 (67100-67254 canceled)
F4U-5P	121999-122002	FG-4	67255-67754 (all canceled)
F4U-5	122003-122014	FG-1	76139-76148
F4U-5N	122015-122018	FG-1D	76149-76449
F4U-5P	122019-122022	FG-3	76450
F4U-5	122023-122036	FG-1	76451-76739
F4U-5N	122037-122040	FG-1D	87788-88453
F4U-5	122041-122044	F2G-1	88454-88458
F4U-5P	122045-122048	F2G-2	88459-88871 (88464-88871 canceled)
F4U-5	122049-122057	FG-1D	92007-93301 (92702-93301 canceled)
F4U-5N	122058-122061	F3A-1	04515-04774
F4U-5P	122062-122065	F3A-1	08550-08797
F4U-5	122066	F3A-1	11067-11646 (11294-11646 canceled)
F4U-5	122153-122166		

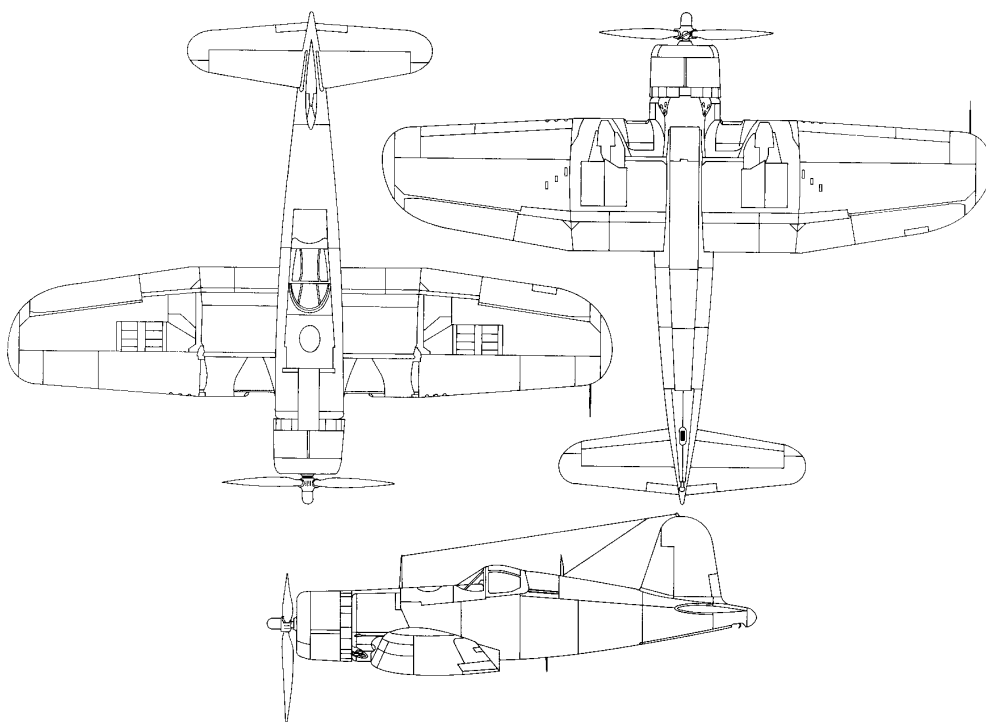

*Line drawings for the F4U-1.*

## F6F Hellcat

Among the Navy's successful aircraft, the Hellcat enjoys a most, if not the most, special place. The Grumman Company's F4F Wildcat served well by taking the heat from the Japanese Zero while at a significant, but hardly overwhelming degree, technologically inferior. The F6F, begun in 1941, would deploy in the summer of 1943, quickly prove itself the Zero's superior, and become the Navy's frontline fighter in the long march across the Pacific to Tokyo Harbor and the end of World War II. The Navy accepted a total of 12,275 Hellcats; it was last reported in squadron by VC-4 on 31 August 1953.

### ***Models Accepted from the Manufacturer (New Builds)***

#### **XF6F-1/2/3:**

The original contract, dated 30 June 1941, called for two prototypes to be designated XF6F-1 and powered by the Wright R-2600 engine. Before they were built, the Navy decided to change the powerplants and equip one of the prototypes with the Pratt & Whitney R-2800. The aircraft powered with the Wright R-2600 was accepted as XF6F-1, the one powered by the Pratt & Whitney R-2800 was accepted as the XF6F-3. A third aircraft was equipped with the Wright R-2600 that was fitted with a turbo-supercharger and accepted as XF6F-2.

#### **F6F-3:**

Specifications for the F6F-3 are as follows:

Crew	one
Length	33 ft 7 in
Span:	
open	42 ft 10 in
folded	16 ft 2 in
Wing area	334 sq ft
Height	13 ft 1 in
Weight:	
empty	9,109 lbs
combat	15,509 lbs
Range	1,335 statute miles
Engine	Pratt & Whitney R-2800-10
Ordnance:	
bombs	2,000 lbs
guns	six .50 cal. fixed forward firing

#### **F6F-3E:**

F6F-3 equipped with APS radar.

#### **F6F-3N:**

F6F-3 equipped for night operations.

#### **XF6F-4:**

This was the original XF6F-3 equipped with a two-speed Pratt & Whitney R-2800 engine.

#### **F6F-5:**

The main differences between the F6F-3 and the F6F-5 were in a reshaped windshield, increased armor,



*An F6F-3 Hellcat, circa mid-1943.*

increased strength, a close fitting cowl, spring tab ailerons, and a smoother finish. The F6F-5 has about 15 percent increase in speed over the F6F-3.

**F6F-5N:**

The F6F-5 equipped for night operations.

**XF6F-6:**

Experimental version, never in production. Powered by a new and more powerful Pratt & Whitney R-2800 engine called the "C" series. It had a four-bladed propeller.

**Other Designations**

**F6F-5D:**

Modified as a drone directing aircraft.

**F6F-5K:**

Modified as a target or assault drone.

**F6F-5P:**

Equipped for photo-reconnaissance.

**Bureau Numbers**

XF6F-1/4	02981
XF6F-1/3	02982
F6F-3	04775-04958
F6F-3	08798-09047
F6F-3/3N	25721-26195
F6F-3/3N/3E	39999-43137
F6F-5/5N	58000-58999
F6F-3	65890-66244
F6F-5	69992-70187
XF6F-6	70188
F6F-5/5N/5P	70189-70912
XF6F-6	70913
F6F-5/5N/5P	70914-72991
F6F-5/5N/5P	77259-80258
F6F-5	93652-94751 (94522-94751 canceled)
F6F-5N	108226-109272 (108226-109272 canceled)
F6F-5	111349-111748 (all canceled)

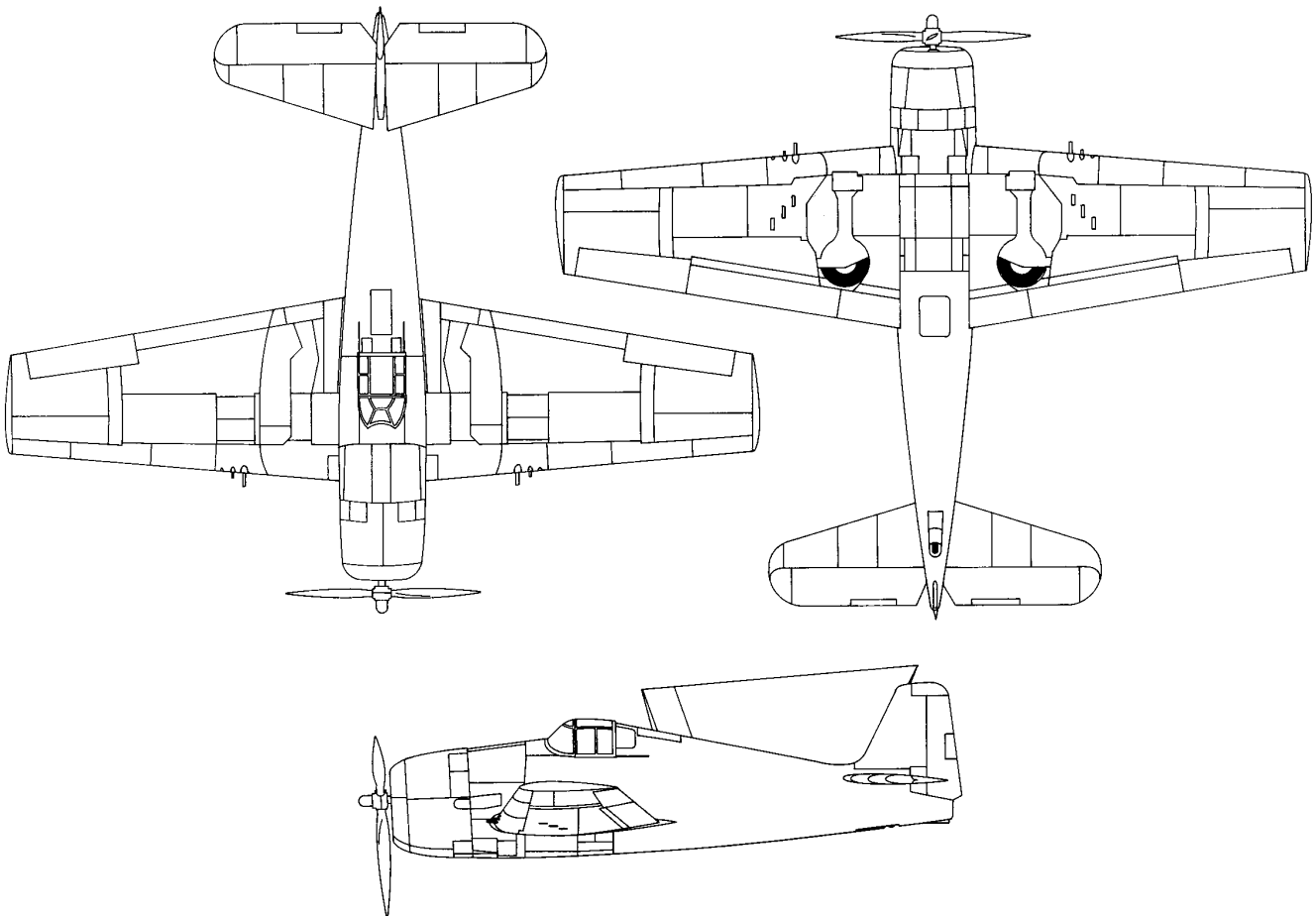

*Line drawings for an F6F-3.*

## F7F Tigercat

Another of the Navy's fighters produced in World War II but never saw action in that conflict and was quickly replaced by jet power. The Tigercat was a twin-engine, tricycle landing gear, carrier-based plane with greater air-to-ground capability than was normal in a Navy aircraft designated fighter. The Navy awarded Grumman the initial contract for the F7F in June 1941. The plane first flew on 3 November 1943. VMF-911 and VMF(N)-531 took the initial deliveries in January 1944. Some F7Fs saw land-based action with the Marine Corps in Korea. On 31 January 1954, VJ-62 reported a F7F-3N and -4N, the last time Tigercats were reported in squadron. A total of 364 were accepted.

### *Model Designations Accepted from the Manufacturer (New Builds)*

#### **XF7F-1:**

Experimental version of the F7F-1.

#### **F7F-1N:**

Night fighter powered by two Pratt & Whitney R-2800-22W engines and equipped with radar.

#### **XF7F-2N:**

Experimental version of the F7F-2N.

#### **F7F-2N:**

Same as F7F-1N but equipped for two crewmen, a pilot and a radar operator. Powered by two Pratt & Whitney R-2800-22W engines.



*An XF7F-1 Tigercat in flight, December 1943.*



**F7F-3:**

This version was similar to the F7F-2N but built for pilot only; the radar operator's place had been fitted with an extra fuel tank. It was powered with the upgraded Pratt & Whitney R-2800-34W.

**F7F-3N:**

Another two-place plane. The radar operator station was restored in place of the fuel tank. Also, this version was equipped with a nose radome.

**F7F-4N:**

Structurally modified to correct most of the carrier suitability problems encountered in earlier versions. The F7F-4N was a two-place night fighter with radar operator and AN/APS-19 radar in a nose radome and powered by two Pratt & Whitney R-2800-34W engines. Characteristics for the F7F-4N are as follows:

Crew	Two
Power Plant	Two 1,700 hp Pratt & Whitney R-2800-34W
Combat Radius	305 nautical miles
Weight	
Maximum Takeoff	24,139 lbs
Basic	18,518 lbs
Empty	17,518 lbs
Dimensions	
Wing	
Area	455 sq ft
Span	51 ft 6 in
Length	46 ft 11 in
Height	16 ft 7 in
Ordnance:	Four 20-mm fixed wing guns with 800 rounds.

Provisions on wings and fuselage for launching rockets, bombs, torpedoes and mines.  
Maximum bomb capacity was 4,600 lbs

**Other Designations:**

**F7F-1:**

A designation that never existed anywhere but on paper. No bureau number was assigned to an F7F-1 and no record has yet surfaced to indicate that an aircraft with the F7F-1 designation was accepted into Navy inventory.

**F7F-2P:**

F7F-2 modified for photographic reconnaissance.

**F7F-3P:**

F7F-3 modified for photographic reconnaissance.

**Bureau Numbers**

XF7F-1	03549-03550
F7F-3	69740-69989
F7F-1N	80259-80260
XF7F-2N	80261
F7F-1N	80262-80293
F7F-2N	80294-80358
F7F-3	80359-80547
F7F-4N	80548
F7F-3N	80549-80608
F7F-4N	80609-80620
F7F	80621-80758 canceled
F7F-3	116729-117728

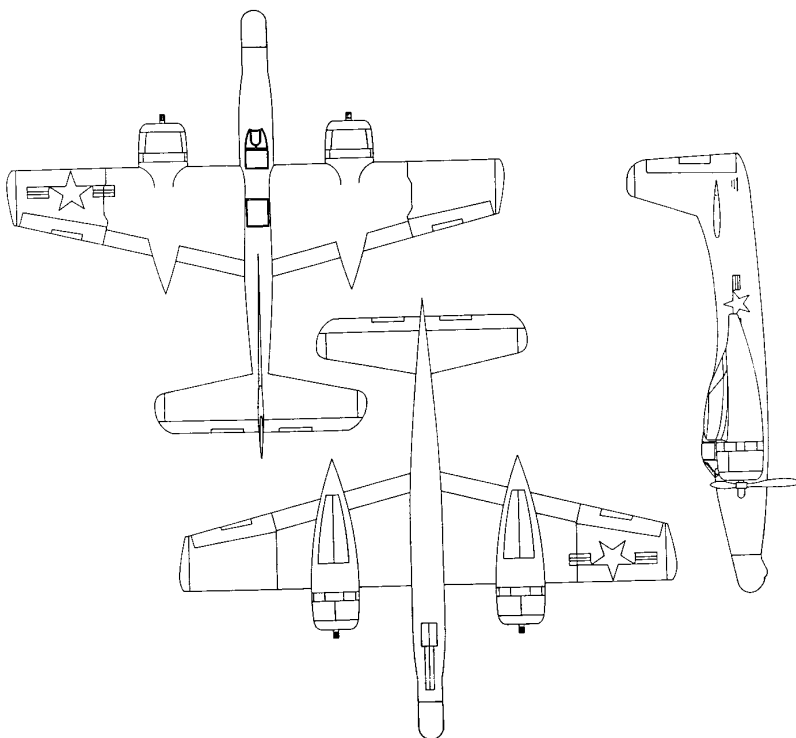

*Line drawings for the F7F.*

## F7U Cutlass

The Vought Company designed the Cutlass as a tailless, carrier-based fighter for high speed and high rate of climb. Three models were designed, F7U-1, F7U-2 and F7U-3, but owing to problems with the power plant in the F7U-2, only the F7U-1 and F7U-3 were produced. Experience with the F7U-1 indicated that the F7U-3 would benefit from redesign of the airframe. The most obvious of the changes was in the nose section. All F7U-1s served as trainers; only the F7U-3 deployed in the fleet as a fighter aircraft.

The Navy awarded Vought a contract for the XF7U-1 on 25 June 1946. The aircraft first flew in August 1948. The first squadron delivery of an F7U-3 did not occur until May 1954; the Cutlass was last reported in squadron less than four years later on 30 November 1957. A total of 305 F7Us were delivered to the Navy.



An F7U-3 Cutlass during a test flight, with an F6U-1 Pirate chase plane.

### Models Accepted from the Manufacturer (New Builds)

**XF7U-1:**

Experimental model of the F7U-1.

**F7U-1:**

Initial production model of the Cutlass. Used for training only.

**F7U-3:**

Production model assigned to fleet squadrons. Specifications for the F7U-3 are as follows:

- Crew One
- Engine 2 Westinghouse 4,000 lbs J46-WE-8 engines

**Weights:**

- empty 18,500 lbs
- combat 24,068 lbs

**Armament:**

- bombs four pylons, 2,000 lbs
- guns four 20 mm cannon

- Range about 575 nautical miles
- Height 14 ft 4 in
- Length 43 ft 1 in
- Wing span 39 ft 8 in

**F7U-3M:**

F7U-3 with provisions for launching four guided missiles.

**F7U-3P:**

F7U-3 equipped for photographic reconnaissance.

### Bureau Numbers

- XF7U-1 122472-122474
- F7U-1 124415-124434 (124429-124434 canceled)
- F7U-2 125322-125409 (all canceled)
- F7U-3 125410-125411 (all canceled)
- F7U-3 128451-128478
- F7U-3 129545-129676
- F7U-3M 129677
- F7U-3 129678-129697
- F7U-3M 129698-129744
- F7U-3P 129745-129756
- F7U-3 136912-136963 (all canceled)
- F7U-3P 136964-136965 (all canceled)
- F7U-3M 139868-139917

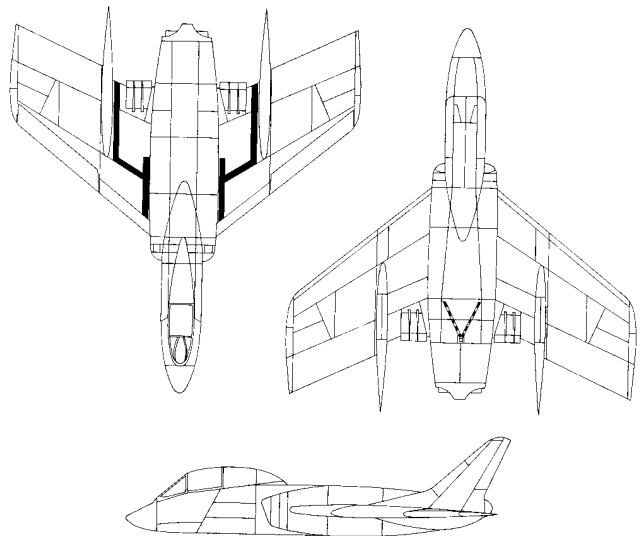

Line drawings for an F7U-3.

## F8F Bearcat

In November 1943, the Navy awarded Grumman a contract to develop a fighter aircraft that could operate from all carriers rather than being limited to the largest of ships. To meet the requirement, Grumman engineers pursued a derivative of the F6F Hellcat. Designated the F8F Bearcat by the Navy, Grumman's Design G-58 first flew on 31 August 1944. It was delivered on 21 May 1945, but was not ready for service before World War II ended. The F8F was the last piston engine fighter Grumman would build for the Navy. A total of 1,263 Bearcats were procured.

### Models Accepted from the Manufacturer (New Builds)

#### XF8F-1:

Experimental version of F8F-1.

#### XF8F-1N:

Experimental version of the F8F-1N night fighter.

#### XF8F-2:

Experimental version of the F8F-2.

#### F8F-1:

Specifications for the F8F-1 are as follows:

Crew	one
Length	27 ft 8 in
Height	12 ft 2 in
Span:	
open	35 ft 6 in
folded	23 ft 9 in
Wing area	244 sq ft
Weights:	
empty	7,323 lbs
combat	9,672 lbs
Range	217 nautical miles (combat)
Engine	one Pratt & Whitney 2100 hp R-2800-34W
Ordnance:	
bombs	2,000 lbs
guns	four .50 calibre forward firing fixed in wings

#### F8F-1B:

The F8F-1 with four 20 mm guns replacing the .50 calibers.

#### F8F-1N:

The F8F-1 equipped for night fighting.

#### F8F-2:

F8F-1 but powered by higher rated engine (Pratt & Whitney R2800-30W) and the 20 mm gun installation.

#### F8F-2N:

F8F-2 equipped for night fighting.

#### F8F-2P:

F8F-2 equipped for photographic reconnaissance.



*An XF8F-1 Bearcat.*

### Other Designations

#### F8F-1D and F8F-2D:

F8F-1 and F8F-2 equipped for use as a drone control plane.

#### F3M-1:

Planned designation for F8Fs built by General Motors. The contract ordering these aircraft was canceled at the end of World War II, and the aircraft were never delivered.

### Bureau Numbers

F8F-1	90437-90459
XF8F-1	90460-90461
F8F-1	94752-95048
XF8F-2	95049
F8F-1	95050-95329
XF8F-1	95330
F8F-1	95331-96751 (95499-96751 canceled)
F8F-1	100001-102000 (all canceled)
F8F-1	112529-114528 (all canceled)
F8F-1	121463-121522
F8F-2	121523-121792
F8F-1B	122087-122152
F8F-2	122614-122708

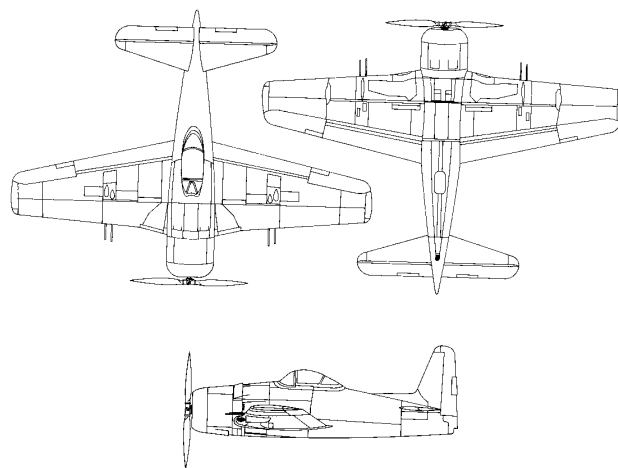

*Line drawings for an F8F-2.*

## F8U (F-8) Crusader

In 1952, the Chance Vought Company submitted a design in response to a Navy request for proposals to build a supersonic daytime fighter aircraft. The Navy awarded Vought the contract on 29 June 1953. The F8U first flew on 25 March 1955, the first delivery was in March 1957. By the time the last delivery was made in January 1965, 1,264 had been accepted for the Navy, the Marine Corps and foreign military use. The Crusader was last reported in squadron by VFP-206 on 1 April 1987 at NAF Washington, D.C. A single-seat, single-engine daytime fighter, the F8U was distinctive for its high wing with variable incidence to alter landing speed. The F8U was redesignated F-8 in 1962.

### ***Model Designations Accepted from the Manufacturer (New Builds)***

**XF8U-1:**

Experimental version of the F8U-1.

**F8U-1 (F-8A):**

Single place, swept-wing, carrier-based day fighter. Equipped to carry AIM-9 Sidewinder missiles.

**F8U-1E (F-8B):**

F-8A equipped with AN/APS-67 visual assist radar.

**F8U-1P (RF-8A):**

Photographic version of F-8A

**F8U-1T (TF-8A):**

Two-seat trainer

**XF8U-2:**

Experimental version of the F8U-2

**F8U-2 (F-8C):**

Improved version of F-8B with improved engine and fixed ventral fins. Characteristics of F8U-2 (F-8C) are as follows:

Crew	One
Power Plant	Pratt & Whitney J57-P-16
Combat Range	1,195-1,295 nautical miles
Weight	
Empty	16,483 lbs
Basic	17,673 lbs
Design	23,192 lbs
Maximum Combat	24,475 lbs
Maximum Takeoff	27,938 lbs (catapult)
Maximum Landing	22,000 lbs (arrested)
Dimensions	
Wing	
Area	375 sq ft
Span	35 ft 8 in



*An F8U-1 Crusader prepares for take off from Hensley Field, Dallas, Texas.*

Length	54 ft 3 in
Height	15 ft 9 in
Tread	9 ft 8 in
Ordnance	Four 20-mm aircraft guns front fuselage and 500 rounds. Thirty-two 2.75-inch rockets carried internally or in rocket pack, centerline fuselage or two AIM-9 missiles externally on pylon each side of fuselage.

**F8U-2N (F-8D):**

Similar to F-8C. Limited all-weather aircraft with AN/APQ-83 radar, autopilot, higher thrust engine and additional fuel capacity. Equipped to carry four Sidewinder missiles.

**F8U-2NE (F-8E):**

Similar to F-8D except equipped with AN/APQ-94 radar with larger antenna.

**F8U-3:**

Improved version of F8U with all-weather capabilities.

**Other Designations**

**F8U-1D (DF-8A):**

Configured as a high-speed control aircraft for Regulus I/II missile.

**F8U-1KD (QF-8A):**

Configured as a Regulus I missile high-speed trounce and control aircraft.

**DF-8F:**

Configured for remote control of QF-9F and QF-9G aircraft and BQM-34A, AQM-34B and AQM-34C drones.

**RF-8G:**

F-8A modernized for increased service life and reconnaissance capabilities.

**F-8H:**

F-8D modified to include external wing store capability, increased strength fuselage, lead-launch computer and other improvements.

**F-8J:**

F-8E with increased fuselage and wings, and other improvements.

**F-8K:**

Similar to F-8C but with structural changes to fuselage, wing and landing gear.

**F-8L:**

Similar to F-8B but with structural changes to fuselage, wing and landing gear.

**F-8M:**

Similar to F-8A but with structural changes to fuselage, wing and landing gear.

**Bureau Numbers**

XF8U-1	138899-138901 138901 (canceled)
F8U-1 (F-8A)	140444-140446, 141336-141362, 142408-142415, 143677-143821, 144427-144606 (144462-144606 canceled)
F8U-1E (F-8B)	145416-145545
F8U-1P (RF-8A)	141363, 144607-144625, 145604-145647, 146822-146905 (146902-146905 canceled), 147078-147084 (canceled)
F8U-1T (TF-8A)	145648-145659 (canceled)
XF8U-2	140447-140448
F8U-2 (F-8C)	145546-145603, 146906-147034
F8U-2N (F-8D)	147035-147077 (147073-147077 canceled), 147896-147925, 148627-148710
F8U-2NE (F-8E)	149134-149227, 150284-150355, 150654-150683, 150843-150932, 151732-151755
F8U-3	146340-146341, 147085-147100 (147088-147100 canceled)

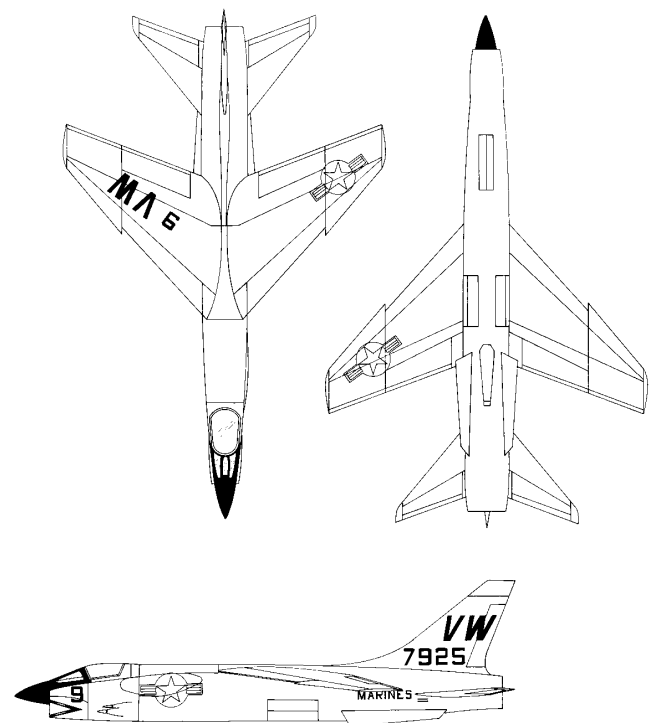

*Line drawings for an F8U.*

## F9F (F-9) Panther and Cougar

The McDonnell Company of St. Louis built the Navy's first all jet aircraft and demonstrated that the jet engine was adaptable to naval aviation, but it was Grumman's F9F Panther that became the first Navy jet fighter to shoot down another jet fighter.

Grumman's departure from propeller driven fighters was accompanied by abandoning the tradition of naming the Company's fighters "Cats." However, the feline connection lived on with Panther and Cougar and eventually returned to original policy with the F-14 Tomcat.

Grumman received a Navy contract on 16 December 1946 to produce a jet powered, straight wing, carried based fighter. The aircraft Grumman proposed first flew on 21 November 1947 and was eventually designated and named the F9F-2 Panther. It was first delivered to Navy squadron in May 1949 and remained in service until October 1958. The Navy accepted a total of 1,388 Panthers with designations of F9F-2, F9F-3, F9F-4 and F9F-5.

The Panther's success led Grumman to design a swept wing derivative and propose it to the Navy. The new design retained the fuselage of the Panther but included a swept wing and tail. The Navy awarded Grumman a contract for this new aircraft on 2 March 1951. It made its first flight on 20 September and was named the Cougar but retained the F9F designation. The Cougar was first delivered to the Navy in November 1952 and remained in squadron until February 1960. The Navy accepted a total of 1,985 Cougars with the designations F9F-6, F9F-7 and F9F-8.

### *Models Accepted from the Manufacturers (New Builds)*

#### *Panther*

**XF9F-2:**

Experimental version of the F9F-2. Straight wing. Powered by Rolls Royce Nene engine.

**F9F-2:**

Powered by Pratt & Whitney J42-P-8 engine.

**XF9F-3:**

Experimental version of the F9F-3. Powered by Allison J33A-8 engine.

**F9F-3:**

Powered by Allison J33-A-8 engine. These aircraft were converted to the F9F-2 configuration and powered by the J42 engine.

**XF9F-4:**

Experimental version of the F9F-4. Powered by the Allison J33-A-16 engine.

**F9F-4:**

Powered by the Allison J33-A-16 engine.

**XF9F-5:**

Experimental version of the F9F-5. Powered by the Pratt & Whitney J48-P-6 engine.

**F9F-5:**

Specifications for the F9F-5 are as follows:

Crew	one
Length	38 ft
Height	12 ft 3 in
Span:	
open	38 ft
folded	23 ft 5 in
Wing area	250 sq ft



*An XF9F-2 Panther, November 1947.*

**Weights:**

empty            10,147 lbs  
 combat         15,359 lbs

Engine            Pratt and Whitney J48-P-6

**Performance:**

Combat radius   420 nautical miles  
 Cruising speed   418 nautical mph

**Ordnance:**

bomb              3,465 lbs total capacity  
 guns              four 20 mm guns in fuselage

**F9F-5P:**

F9F-5 equipped for photo reconnaissance.

### ***Cougar***

**XF9F-6:**

Experimental version. Swept wing and swept tail.  
 Powered by Pratt & Whitney J48-P-6.

**F9F-6 (Redesignated F-9F):**

Powered by Pratt & Whitney J48-P-6.

**F9F-6P:**

F9F-6 equipped for photo reconnaissance.

**F9F-7 (Redesignated F-9H):**

Similar to F9F-6 but powered by Allison J33-A-16A engine.

**F9F-8 (Redesignated F-9J):**

The last single-seat version of the Cougar. It had additional fuel storage and an extended fuselage. Specifications for the F9F-8 (F-9J) are as follows:

Crew              one  
 Length            41 ft 6 in  
 Height            12 ft 3 in  
 Span:  
     open            34 ft 6 in  
     folded         15 ft 8 in  
 Wing area        337 sq ft

**Weights:**

empty            11,628 lbs  
 combat         17,125 lbs

Engine            Pratt & Whitney J48-P-8

**Performance:**

*An F9F-6 Cougar in flight, circa 1952.*

Combat range 1,120 nautical miles  
 Cruising speed about 480 nmph  
 Ordnance:  
 bombs 4,000 lbs total capacity  
 guns four 20 mm guns in fuselage

**F9F-8P (Redesignated RF-9J):**

F9F-8 equipped for photo reconnaissance.

**YF9F-8T (Redesignated YTF-9J):**

Prototype of a trainer configuration of the F9F-8.

**F9F-8T (Redesignated TF-9J):**

Two-seat trainer version of the F9F-8.

**Other Designations**

**F9F-2KD:**

F9F-2 modified and equipped as combination target drone and control aircraft for Regulus missile training program.

**F9F-2P:**

F9F-2 equipped for photo reconnaissance.

**F9F-5KD (Redesignated DF-9E):**

F9F-5 modified for use as a target drone or a control plane.

**F9F-6D (Redesignated DF-9F):**

F9F-6 modified and equipped to control either the F9F target drone or the KDA-1 target.

**F9F-6K (Redesignated QF-9F):**

F9F-6 modified as a target drone.

**F9F-6K2 (Redesignated QF-9G):**

F9F-6 modified as a Research Development and Evaluation target aircraft.

**YF9F-8B (Redesignated YAF-9J):**

Prototype of F9F-8B.

**F9F-8B (Redesignated AF-9J):**

F9F-8 equipped to perform attack missions. It had increased wing area, flap area, fuel capacity and a cambered leading edge. Specifications for the F9F-8B are as follows:

Crew one  
 Length 41 ft 9 in  
 Height 12 ft 3 in  
 Span:  
     open 34 ft 6 in  
     folded 15 ft 8 in  
 Wing area 337 sq ft  
 Weights:  
     empty 11,866 lbs  
     combat 17,345 lbs  
 Engine Pratt & Whitney J48-P-8A

Performance:

Combat radius 295 nautical miles  
 Cruising speed 418 nautical mph

Maximum Weight

catapult launch 24,763 lbs

Ordnance:

bomb two wing stations for fuel tanks, bombs, or air-to-air and air-to-surface missiles

guns four 20 mm guns in fuselage

**F9F-9:**

Planned designation for an F9F-8 powered by a Wright J65-W-6 engine. This aircraft was never delivered to the Navy.

**Bureau Numbers**

XF9F-2 122475  
 XF9F-3 122476  
 XF9F-2 122477  
 F9F-2 122614-122708  
 F9F-3 123016-123083  
 XF9F-4 123084  
 XF9F-5 123085  
 F9F-3 123068-123087 (123087 canceled)  
 F9F-2 123397-123740 (123714-123740 canceled)  
 F9F-5 125080-125152  
 F9F-4 125153-125225  
 F9F-5 125226-125313  
 F9F-5P 125314-125321  
 F9F-5 125414-125443  
 F9F-5 125489-125499  
 F9F-5 125533-125648  
 F9F-5 125893-126256  
 F9F-6 126257-126264  
 F9F-5P 126265-126290  
 F9F-5 126627-126669  
 XF9F-6 126670-126672  
 F9F-2 127086-127215  
 F9F-6 127216-127470  
 F9F-5P 127471-127472  
 F9F-6P 127473-127492  
 F9F-6 128055-128294  
 F9F-6P 128295-128310  
 F9F-7 130752-130919  
 F9F-6 130920-131062  
 F9F-8 131063-131251  
 F9F-6P 131252-131255  
 F9F-8 134234-134244  
 F9F-6 134245-134433  
 F9F-6P 134446-134465  
 F9F-8 138823-138898



F9F-8      141030-141229  
F9F-8      141648-141666  
YF9F-8T   141667  
F9F-8P    141668-141727  
F9F-8T    142437-142532

F9F-8T    142945-143013  
F9F-8      144271-144376  
F9F-8P    144377-144426  
F9F-8T    146342-146425  
F9F-8T    147270-147429

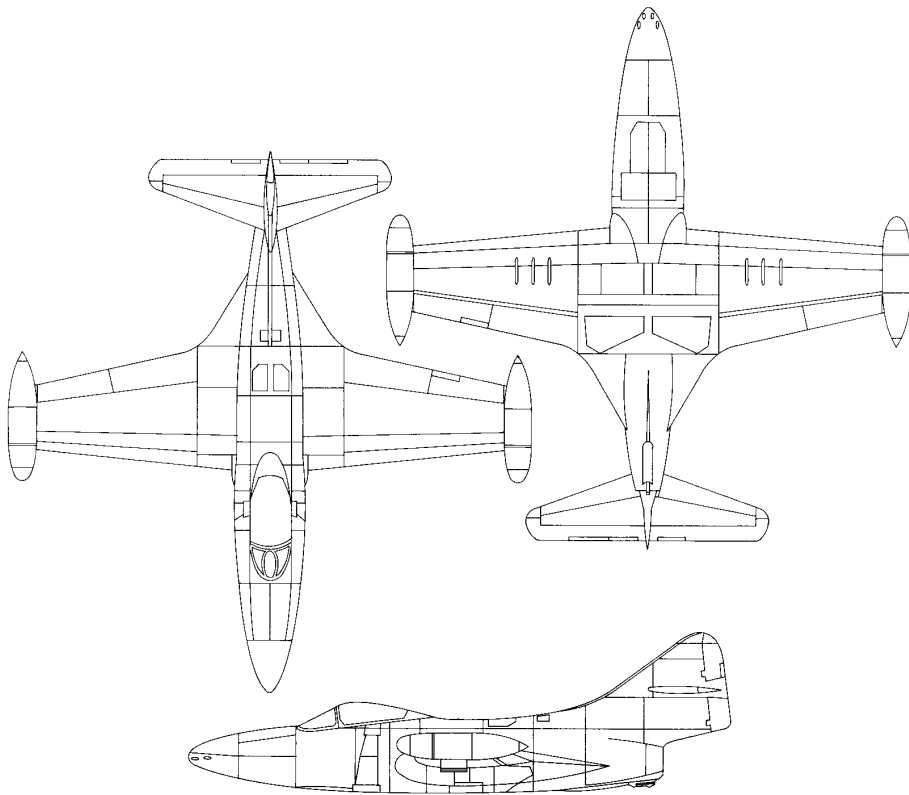

*Line drawings for an F9F Panther.*

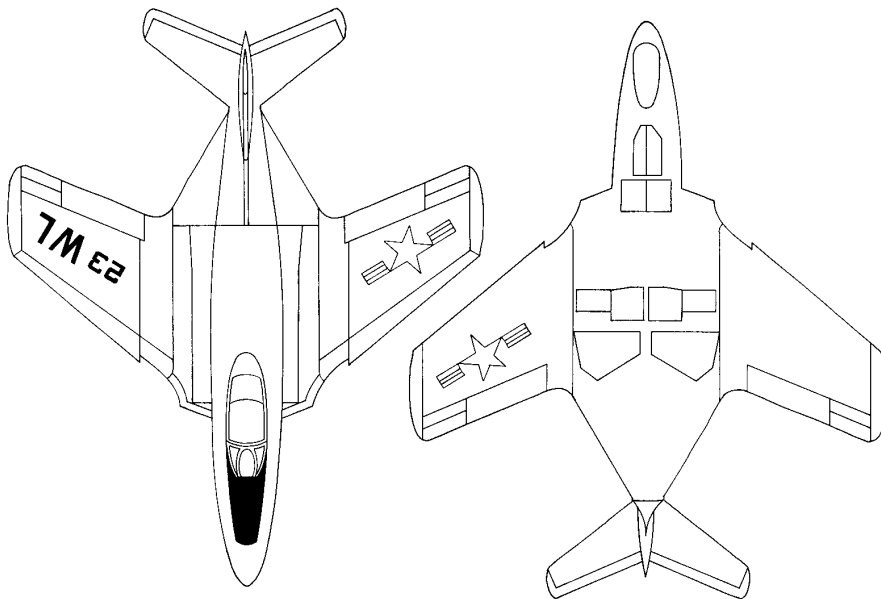

*Line drawings for an F9F Cougar.*

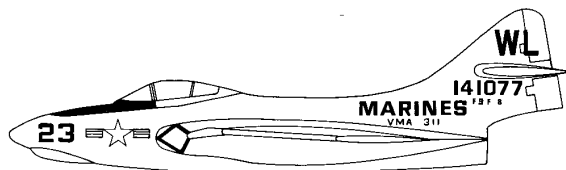

## F/A-18 Hornet

On 6 June 1974, the Navy released to the aerospace industry a pre-solicitation notice for the development of a new fighter and attack aircraft. Six manufacturers responded. On 28 August, the Chief of Naval Operations released the operational requirement for a strike fighter aircraft. The intent was to produce a fighter that would supplement the F-14 Tomcat and eventually replace both the F-4 Phantom II and the light attack A-7 Corsair II. This was to be done at the least expense possible, and Congress directed that the aircraft was to be a derivative of the YF-16/YF-17 then under evaluation by the Air Force.

On 2 May 1975, the Navy announced the selection of McDonnell Douglas' F-18 aircraft design. The General Electric Corporation was awarded a contract to develop the aircraft's engine. McDonnell Douglas was selected as the prime contractor. The Northrop Corporation was selected to build the after fuselage portion of the aircraft.

By the end of the 1980s, the F/A-18 Hornet, had proved to be a truly multi-mission tactical aircraft. It brought to the fleet a light-attack capability and a potent fighter complement to the F-14 in the outer air battle.

First flight	18 Nov 1978
First reported in squadron	VFA-125
Number delivered as of 1 Oct 1993	859

### **Model Designations Accepted from the Manufacturer (New Builds)**

**F/A-18A:**

The original version. Single seat, capable of carrying bombs and air-to-air guided missiles.

**F/A-18B:**

Training version of the F/A-18A with combat capability. This designation replaced TF/A-18A.

**F/A-18C:**

Single seat with maximum level speed of more than Mach 1.8. The F/A-18C differs from F/A-18A in its ability to carry the AMRAAM missile, the infra-red Maverick missile, and the Airborne Self-Protection Jammer (ASPJ). There is also an enhanced avionics suite and night attack capability. Specifications for the F/A-18C are as follows:

Dimensions:

Wing Span	37 ft 6 in
Length	56 ft
Height	15 ft 3 1/2 in

Weight:

Empty	23,050 lbs
Maximum fuel weight, internal and external	17,592 lbs



*An F/A-18A Hornet takes off from Lambert-St. Louis International Airport on its first flight, November 1978.*

Take off weight for fighter mission	36,710 lbs
Take off weight for attack mission	49,224 lbs

**Armament:**

nine external stations for missiles and bombs  
M61 20 mm six-barrel gun in nose

**Engines:**

two General Electric F404-GE-400

**F/A-18D:**

Two seat version of the F/A-18C with reconnaissance capability.

**TF/A-18A:**

Training version with combat capability. This designation was replaced with F/A-18B.

### **Modifications to Existing Airframes**

**F/A-18D (RC):**

Tactical reconnaissance version.

#### **Other Designations**

**CF-18:**

Version for Canada.

**EF-18A and EF-18B:**

Versions for Spain.

**AF-18A and ATF-18A:**

Versions for Australia.

#### **Bureau Numbers**

F/A-18A	160775-160785
F/A-18A	161213-161216
F/A-18A	161248
F/A-18A	161250-161251
F/A-18A	161353
F/A-18A	161358-161359
F/A-18A	161361-161367

F/A-18A	161519-161528	TF/A-18A	162419
F/A-18A	161702-161703	TF/A-18A	162427
F/A-18A	161705-161706	TF/A-18A	162842
F/A-18A	161708-161710	TF/A-18A	162850
F/A-18A	161712-161713	TF/A-18A	162857
F/A-18A	161715-161718	TF/A-18A	162864
F/A-81A	161720-161722	TF/A-18A	162870
F/A-18A	161725-161726	TF/A-18A	162885
F/A-18A	161728-161732	TF/A-18A	163104
F/A-18A	161734-161739	TF/A-18A	163110
F/A-18A	161741-161745	TF/A-18A	163115
F/A-18A	161747-161761	TF/A-18A	163123
F/A-18A	161925-161931	F/A-18C	163427-163433
F/A-18A	161933-161937	F/A-18C	163435
F/A-18A	161939-161942	F/A-18C	163437-163440
F/A-18A	161944-161946	F/A-18C	163442-163444
F/A-18A	161948-161987	F/A-18C	163446
F/A-18A	162394-162401	F/A-18C	163448-163451
F/A-18A	162403-162407	F/A-18C	163453
F/A-18A	162409-162412	F/A-18C	163455-163456
F/A-18A	162414-162418	F/A-18C	163458-163459
F/A-18A	162420-162426	F/A-18C	163461-163463
F/A-18A	162428-162477	F/A-18C	163465-163467
F/A-18A	162826-162841	F/A-18C	163470-163478
F/A-18A	162843-162849	F/A-18C	163480-163481
F/A-18A	162851-162856	F/A-18C	163483-163485
F/A-18A	162858-162863	F/A-18C	163487
F/A-18A	162865-162869	F/A-18C	163489-163491
F/A-18A	162871-162884	F/A-18C	163493-163499
F/A-18A	162886-162909	F/A-18C	163502-163506
F/A-18A	163092-163103	F/A-18C	163508-163509
F/A-18A	163105-163109	F/A-18C	163699
F/A-18A	163111-163114	F/A-18C	163701-163706
F/A-18A	163116-163122	F/A-18C	163708-163719
F/A-18A	163124-163175	F/A-18C	163721-163762
TF/A-18A	161217	F/A-18C	163764-163770
TF/A-18A	161249	F/A-18C	163772-163777
TF/A-18A	161354-161357	F/A-18C	163779-163782
TF/A-18A	161360	F/A-18C	163985
TF/A-18A	161704	F/A-18C	163987-163988
TF/A-18A	161707	F/A-18C	163990
TF/A-18A	161711	F/A-18C	163992-163993
TF/A-18A	161714	F/A-18C	163995-163996
TF/A-18A	161719	F/A-18C	163998-164000
TF/A-18A	161723	F/A-18C	164002-164004
TF/A-18A	161727	F/A-18C	164006
TF/A-18A	161733	F/A-18C	164008
TF/A-18A	161740	F/A-18C	164012-164013
TF/A-18A	161746	F/A-18C	164015-164016
TF/A-18A	161924	F/A-18C	164018
TF/A-18A	161932	F/A-18C	164020-164021
TF/A-18A	161938	F/A-18D	163434
TF/A-18A	161943	F/A-18D	163436
TF/A-18A	161947	F/A-18D	163441-163442
TF/A-18A	162402	F/A-18D	163445
TF/A-18A	162408	F/A-18D	163447
TF/A-18A	162413	F/A-18D	163454

F/A-18D 163457  
 F/A-18D 163464  
 F/A-18D 163468  
 F/A-18D 163479  
 F/A-18D 163482  
 F/A-18D 163486  
 F/A-18D 163488  
 F/A-18D 163492  
 F/A-18D 163500-163501  
 F/A-18D 163507  
 F/A-18D 163510  
 F/A-18D 163700  
 F/A-18D 163707

F/A-18D 163720  
 F/A-18D 163763  
 F/A-18D 163771  
 F/A-18D 163778  
 F/A-18D 163986  
 F/A-18D 163989  
 F/A-18D 163991  
 F/A-18D 163994  
 F/A-18D 163997  
 F/A-18D 164005  
 F/A-18D 164009  
 F/A-18D 164011  
 F/A-18D 164019

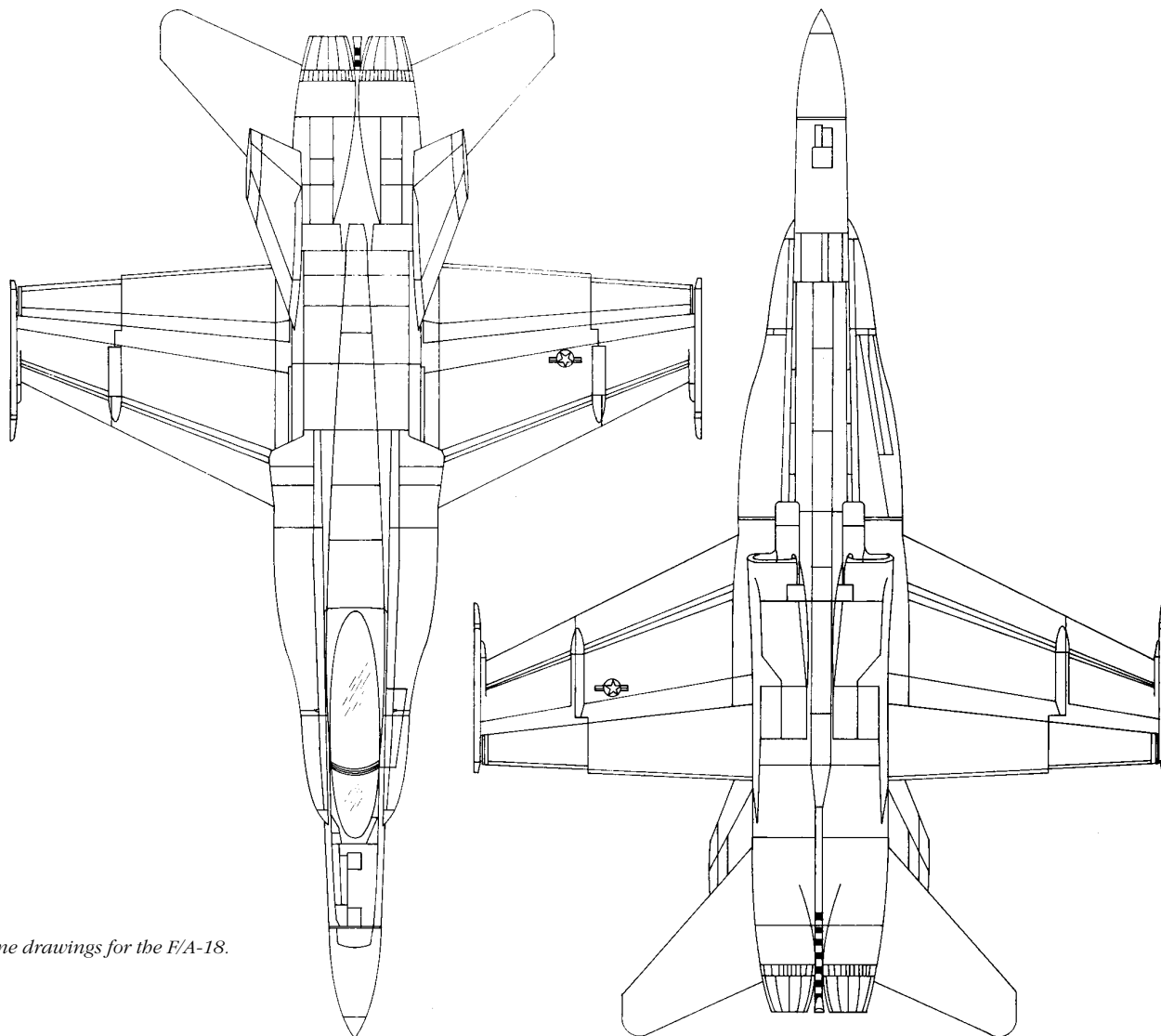

*Line drawings for the F/A-18.*

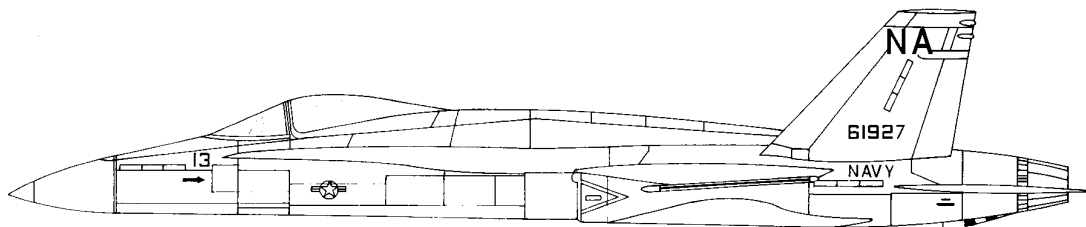

## FH (FD) Phantom

In January 1943, the Navy's decision to build an all jet-powered, carrier-based aircraft led to a contract award to the McDonnell Aircraft Company, St. Louis, Missouri. McDonnell had never designed an aircraft for the Navy, and the Navy had never before sought a jet aircraft. Following the procedure of the day, the Navy assigned a manufacturer's letter to McDonnell for its incorporation into the aircraft's designation. At the time, all usable letters were in use, so the Navy—almost presciently-assigned McDonnell the letter D which was already used by Douglas. On 6 June 1947, the letter was later changed to H; the Phantom was first designated FD and later FH.

The aircraft first flew on 26 January 1945. VF-17A made the first acceptance on 23 July 1947. VMF-122



*The XFD-1 Phantom in flight, later redesignated FH.*

was the last squadron to report a Phantom on 1 July 1950. A total of 61 aircraft were accepted.

### **Model Designations Accepted from the Manufacturer (New Builds)**

**XFD-1:**

Experimental version of the FD-1. The designation was never changed to XFH-1.

**FD-1:**

Production version of the FD-1. Basically the same as the XFD-1 but with some redesign of the vertical tail structure. Designation was later changed to FH-1.

**Characteristics of XFD-1:**

Crew	One
Power Plant	Two 1,560 lb Westinghouse J60 engines
Combat Range	475 nautical miles
Weight	
Gross	8,626 lbs
Empty	6,156 lbs
Dimensions	
Wing Span	42 ft
Length	37 ft 2 in
Height	13 ft 2 in
Ordnance:	None in experimental version. Four fixed .50 cal. guns in FD-1.

### **Bureau Numbers**

XFD-1	48235-48236
FD-1	111749-111848 (111809-111848 canceled)

*Line drawings for the FH.*

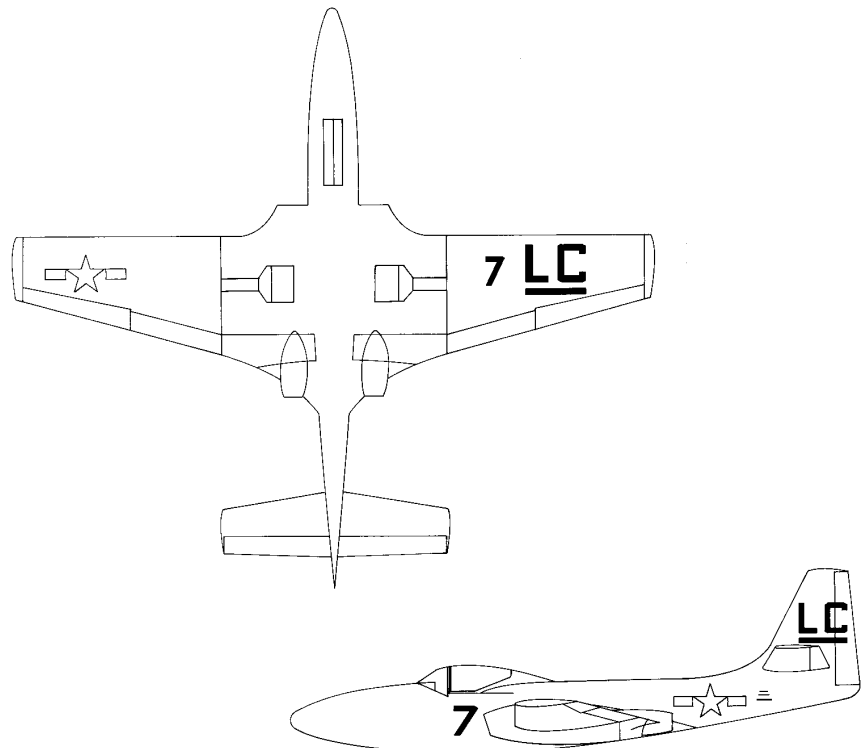

## FJ-3/4 (F-1) Fury

North American's straight-wing Navy FJ-1 of the 1940s led to the swept wing F-86 Sabre; it seemed a logical development for the company to later produce a swept-wing, carrier-based fighter. It would be designated FJ-2 and would first fly on 27 December 1951. All FJ-2s were powered by a single General Electric J47-GE-2 engine with 6,000 pounds thrust; all were assigned to the Marine Corps. The later carrier-based variant was designated FJ-3 and was powered by a single Wright J65-W-4 engine with 7,800 pounds thrust; it first flew in 1953. The FJ-4 had a redesigned fuselage and wings with greater fuel capacity but the same engine as the FJ-3. The FJ-4 was used primarily by the Marine Corps. In 1962, the FJ-3 and FJ-4 were redesignated F-1C and F-1E, respectively. The last Fury was delivered in May 1958. The Fury was last reported in squadron on 30 September 1962.



An XFJ-4 Fury in flight, November 1954.

### Model Designations Accepted from the Manufacturer (New Builds)

#### FJ-3 (F-1C):

Single-engine, sweptwing, single-place, high-performance day fighter. Characteristics of FJ-3 (F-1C) are as follows:

Crew	One
Power Plant	7,800 pound Wright J65-W-4A
Combat Range	990 nautical miles
Weight	
Empty	12,815 lbs
Basic	13,790 lbs
Design	16,482 lbs
Combat	16,632 lbs
Maximum Takeoff	19,390 lbs (catapult)
Maximum Landing	15,000 lbs (arrested)

#### Dimensions

Wing	
Area	288 sq ft
Span	37 ft 1 in
Length	38 ft 7 in

Height	13 ft 8 in
Tread	9 ft
Ordnance on FJ-3 beyond Bureau Number 136118:	
	Four 20 mm guns in forward fuselage with 646 rounds.
	Wing stations to carry: 5 inch rockets; 250, 500 and 1,000 lb bombs; 260 lb fragmentation bomb; two AIM-9 missiles

#### FJ-3M (MF-1C):

FJ-3 equipped to carry AIM-9 Sidewinder missile.

#### XFJ-4:

Experimental version of FJ-4.

#### FJ-4 (F-1E):

Production improvement of the FJ-3.

#### FJ-4B (AF-1E):

FJ-4 with provisions for attack missions.

### Other Designations

#### FJ-3D (DF-1C):

FJ-3 modified for control of Regulus missile.

#### FJ-3D2 (DF-1D):

FJ-3 capable of controlling the F9F-6K and KDA-1.

#### FJ-4F:

FJ-4 with provision for rocket assist.

### Bureau Numbers

FJ-3 (F-1C)	135774-136162, 139210-139278, 139324-139423 (canceled)
FJ-3M (MF-1C)	141364-141443
XFJ-4	139279-139280
FJ-4 (F-1E)	139281-139323, 139424-139530
FJ-4B (AF-1E)	139531-139555, 141444-141489, 143493-143676 (143644-143676 canceled)

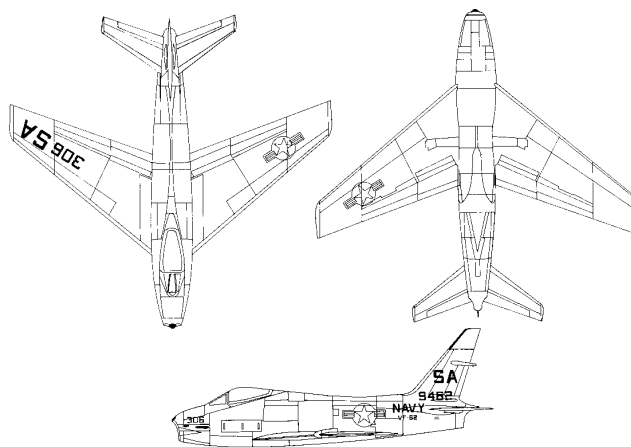

Line drawings for the FJ Fury.

## FM Wildcat

Built by the Eastern Aircraft Division of General Motors to Grumman's F4F Wildcat design, an FM first flew in August 1942. Eastern was made a second production source for this aircraft to allow Grumman to concentrate on the Wildcat's successor, the F6F Hellcat. In all, Eastern delivered 5,927 FMs to the Navy, including those for use by the Allies. An FM was last reported in squadron in November 1945.

### **Model Designations Accepted from the Manufacturer (New Builds)**

#### **FM-1:**

Based on F4F-4, the FM-1 had a gross weight 75 pounds greater than that of the F4F-4. Characteristics of the FM-1 are as follows:

Crew	One
Power Plant	Pratt & Whitney R-1830-86 with 1,200 hp
Combat Radius	324 nautical miles
Weight	
Gross	8,837 lbs
Empty	5,895 lbs
Dimensions	
Wing	
Area	260 sq ft
Span	38 ft
Length	28 ft 10 in
Height	12 ft 2 in
Ordnance:	Four forward-firing .50 cal. guns
with	1,720 rounds.



*An FM-2 Wildcat in flight, April 1944.*

#### **FM-2:**

Based on a Grumman prototype designated XF4F-8, the FM-2 was powered by one Wright R-1820-56 engine of 1,350 hp and had a tail fin slightly taller than the FM-1's.

### **Other Designations:**

#### **XFM-2:**

F4F-4 converted to facilitate production engineering of the FM-2.

#### **FM-2P:**

FM-2 equipped for reconnaissance.

### **Bureau Numbers**

FM-1	14992-15951, 46738-46837
FM-2	15952-16791, 46838-47437, 55050-55649, 56684-57083, 73499-75158, 86297-87719 (86974-87719 canceled)

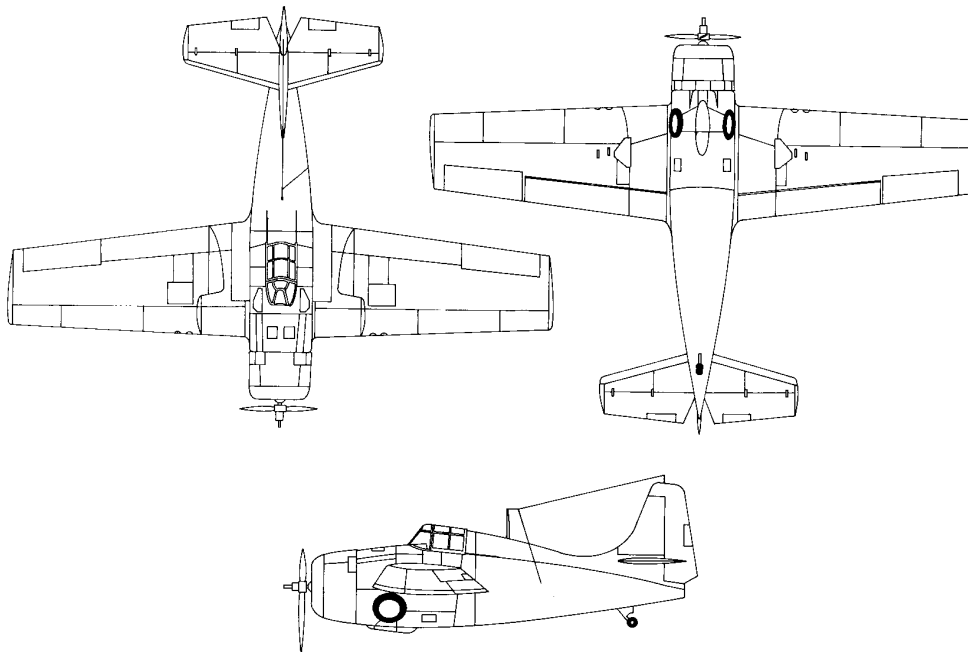

*Line drawings for an FM-2.*

## OV-10 Bronco

In October 1964, the Navy awarded a contract to North American to design a Light Armed Reconnaissance Aircraft (LARA) for the Marine Corps. Two years later, the LARA had developed into a tri-service program to provide a Counter-Insurgency (COIN) aircraft for the United States Armed Forces. HML-267 accepted the first article for the Marine Corps in February 1968. A total of 356 Broncos were accepted for Navy and Marine Corps use and for foreign military sales.

### **Model Designations Accepted from the Manufacturer (New Builds)**

**YOV-10A:**

Prototype of the Bronco.



*A full-scale mock-up of the OV-10 at the North American factor, circa mid-1960s.*

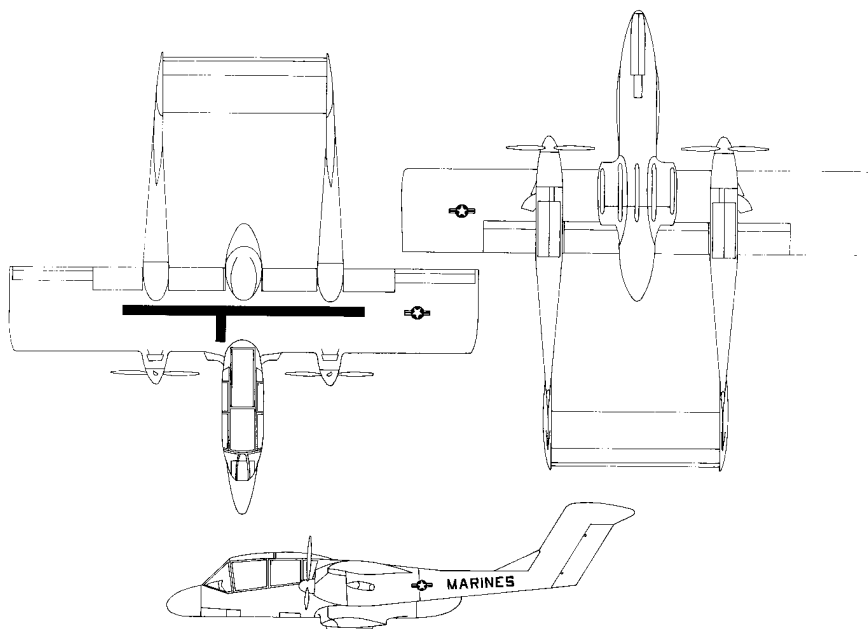

*Line drawings for the OV-10A.*

**OV-10A:**

Production version of the Bronco. It was the only variant accepted for the Marine Corps. Characteristics of the OV-10A are as follows:

Crew	Two
Power Plant	Two 715-shp Garrett Air Research turboprops
Combat Range	789 nautical miles
Weight	
Maximum Takeoff	14,444 lbs
Empty	6,921 lbs
Dimensions	
Wing Span	40 ft 4 in
Wing Area	291 sq ft
Length	41 ft 6 in
Height	15 ft 1 in
Ordnance:	Four 7.62-mm guns, AIM-9 Sidewinders, rockets, bombs, gun pods.

### **Other Designations**

**OV-10D:**

The result of an improvement program to produce what was referred to as the OV-10D Plus configuration. Begun in 1988, the -10D included the Service Life Extension Program, which comprised a wide range of engineering change proposals to update the aircraft and improve its performance. Some structural changes were made and avionics equipment was added. The aircraft was night vision capable.

### **Bureau Numbers**

YOV-10A	152879-152885
OV-10A	155390-155503, 613552, 674652, 674623, 683809, 683799, 683796, 674626



## PB4Y Liberator

*(and its other names and designations)*

By 1942, the Royal Air Force (RAF) was using Consolidated's U.S. Army land-based B-24 Liberator on long-range patrol against German submarines and surface vessels. The RAF's success in this deployment was sufficient to induce the U.S. Navy to acquire a quantity of the type. The B-24D entered Navy inventory as the PB4Y-1 Liberator when VP-51 accepted the first articles in October 1942. The B-24 remained in U.S. Navy service until VJ-62 last reported a P4Y-1P in squadron. At the time of the redesignation in 1962, the only variant of the aircraft remaining in Navy use was the target drone P4Y-2K, which was redesignated QP-4B. A total of 977 -1s and 739 -2s were procured.

Records show that at sometime the PB4Y-1s and PB4Y-2s were both called Liberator, although it was probably the intention always to refer to all -1s as Liberator and all -2s as Privateer. The P4Y-2s, which were PB4Y-2s redesignated, were all called Privateer. The Coast Guard flew some Privateers under the designation P4Y-2G. Other Navy acquisitions included the transport version designated RY-1, RY-2 and RY-3—all of which were called Liberator Express.

### **Model Designations Accepted from the Manufacturer (New Builds)**

#### **PB4Y-1:**

Land-based bomber used mainly for ASW. Dual tail fin. Powered by four Pratt & Whitney R-1830-43s.



*A naval reserve P4Y-2 from NAS Glenview at Gibraltar.*

#### **PB4Y-2:**

Single tail fin, longer fuselage than the -1, additional armament and powered by four Pratt & Whitney R-1830-94s. Redesignated P4Y-2. Characteristics of the PB4Y-2 are as follows:

Crew	11
Power Plant	Four Pratt & Whitney R-1830-43.
Combat Range	1,920 nautical miles
Weight	
Maximum Takeoff	64,000 lbs
Empty	37,464 lbs
Dimensions	
Wing Span	110 ft
Wing Area	1,048 sq ft
Length	74 ft 9 in
Height	29 ft 2 in
Ordnance:	Twelve .50 cal. guns: 2 in the nose turret, 2 in the tail turret, 4 in the waist, 2 in the forward deck and 2 in the after deck. Total of 6,800 rounds. Provisions for four 2,000 pound or eight 1,000 pound or twelve 500 pound bombs; or twelve 324 pound depth charges; or four 2,000 pound or eight 1,000 pound mines.

#### **PB4Y-2B:**

PB4Y-2 modified to launch and control the ASM-N-2 Bat glide bomb. Redesignated P4Y-2B.

#### **PB4Y-2M:**

Demilitarized version of the PB4Y-2 used for weather reconnaissance.

#### **PB4Y-2S:**

Antisubmarine version of the PB4Y-2. Redesignated P4Y-2S.

### **Other Designations**

#### **PB4Y-1P:**

PB4Y-1 equipped for photoreconnaissance. Redesignated P4Y-1P.

#### **PB4Y-1Z:**

PB4Y-1 converted for administrative purposes.

#### **XPB4Y-2:**

Experimental version of the PB4Y-2.

#### **PB4Y-2C:**

PB4Y-2 with an Emerson turret in lieu of the ERCO turret in the bow.

#### **P4Y-2G:**

P4Y-2 flown by the U.S. Coast Guard.

#### **P4Y-2S2:**

Improved version of the P4Y-2S.

**P4Y-2K:**

Equipped as a target drone.

**Bureau Numbers**

PB4Y-1 31936-32085, 32087-32094, 32097-32335,  
38773-38979, 46725-46737, 63915-63991  
(63960-63991 canceled), 65287-65396,  
90132-90271, 90462-90271  
XPB4Y-2 32086, 32095-32096

PB4Y-2 59350-59924 (59554 canceled), 59926,  
59929-59937, 59939-59944, 59946-59948,  
59950-59954, 59970-60009, 66245-66394,  
(66325-66394 canceled), 66795-67054 (all  
canceled), 76839-77138 (all canceled)  
PB4Y-2B 59925  
PB4Y-2S 59927  
PB4Y-2M 59928, 59938, 59945, 59949, 59955-59969

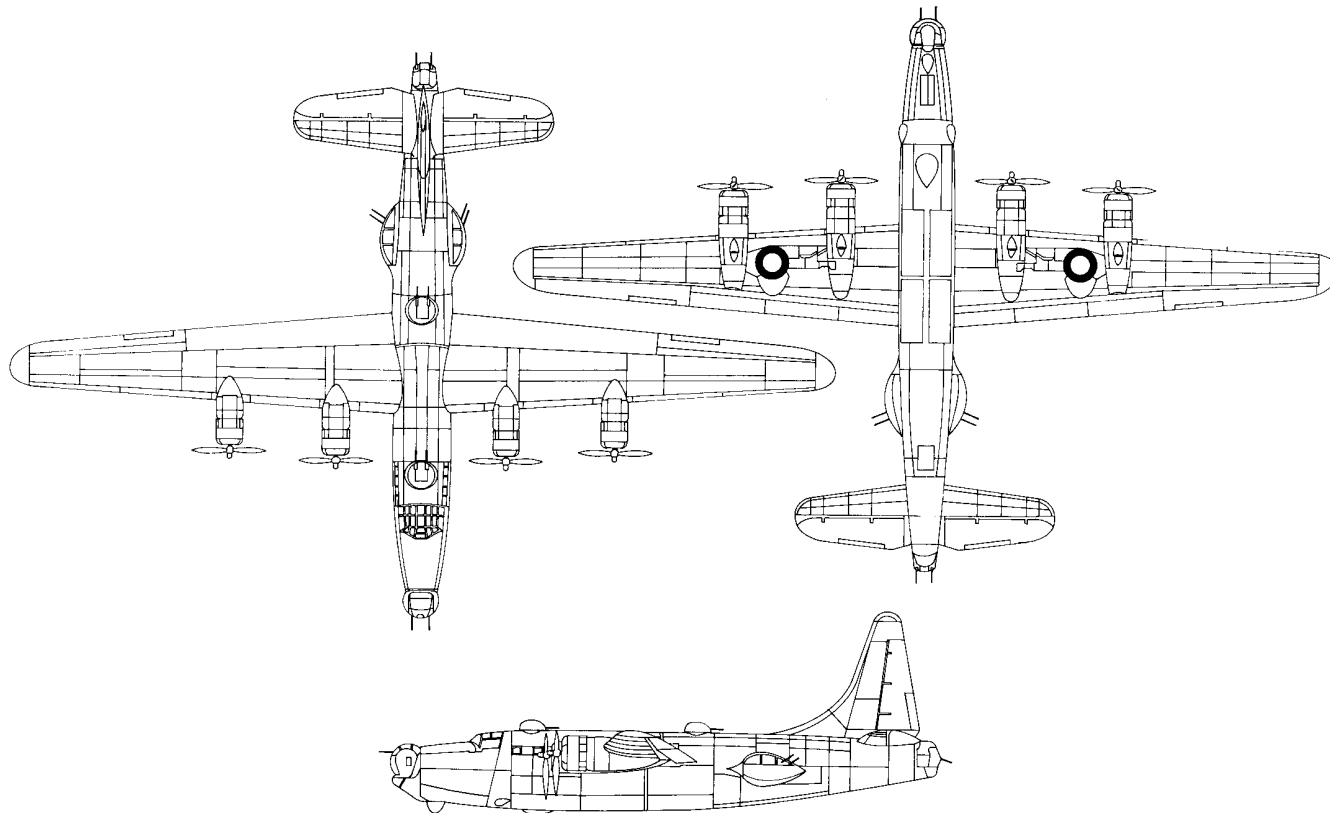

*Line drawings for the PB4Y-2.*

## SB2A Buccaneer

In 1934, the Brewster Aeronautical Corporation designed the XSBA-1 for the Navy and built one article. On 4 April 1939, the Navy awarded Brewster a contract for another Scout Bomber. This contract led to the SB2A Buccaneer. The Navy accepted a total of 771 SB2As of which 468 were for foreign military use. The Navy eventually used some of these aircraft for training, but if any of the 771 SB2As ever saw combat, no record of it has yet been found.



*An SB2A Buccaneer.*

First contract	4 April 1939
First flight	17 June 1941
First reported in squadron	31 January 1943, VMF(N)-531
Last delivery	February 1944
Last reported in squadron	30 Nov 1943 by VMF(N)-532
Number accepted	771

### SB2A-1:

Specifications for the SB2A-1 are as follows:

Weights:

Empty	9,491 lbs
Gross	14,565 lbs

Ordnance:

- Two .30 cal. wing guns
- Two .50 cal. nose (propeller synchroized) guns
- Two .30 cal. flexible guns
- Two 500 or one 1,000 pound bomb

Wing area	379 sq ft
Wing span	47 ft
Height	15 ft 9 in
Length	38 ft 10 in
Max range	1,700 statute miles
Power plant	One 1,700 hp Wright R-2600

### Bureau Numbers

XSB2A-1	1632
XSB2A-1	01005
SB2A-2	00803-00882
SB2A-3	00883-00942
SB2A-4	29214-29375

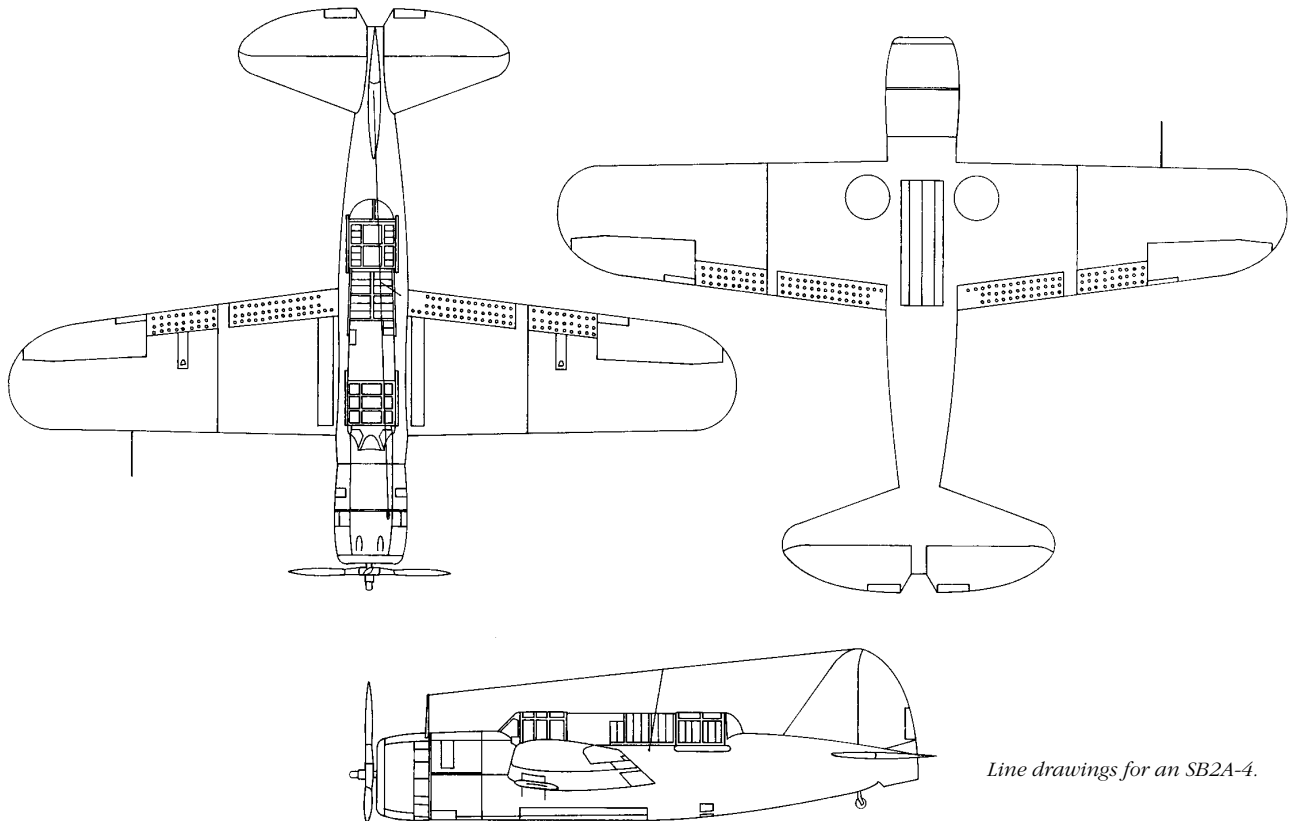

*Line drawings for an SB2A-4.*

## SB2C/SBW/SBF Helldiver

Curtiss added to its list of Navy combat aircraft in December 1942 upon delivering the service's first SB2C Helldiver to VS-9. Powered by the Wright R-2600 Cyclone engine, the SB2C monoplane scout bomber was ordered by the Navy in 1939 as a replacement for the SBD Dauntless. It was Curtiss's first monoplane attack aircraft and would eventually be built in 19 designations by three manufacturers. By the time the Navy accepted the last Helldiver in October 1945, production had reached 6,650. The Helldiver, in its differ-

ent models, carried both fixed wing guns and flexible guns ranging from .30 to .50 calibre and 20 mm. Bomb capability was based on two external wing racks and an internal bomb bay equipped with displacement gear, or crutch, to release a single bomb. Some models could carry 5 inch rockets.

First contract	15 May 1939
First flight	18 Dec 1940
First reported in squadron	15 Dec 1942
Last delivery	Oct 1945
Number accepted	6,650
Last reported in squadron	1 Jun 1949



An XSB2C-1 Helldiver, December 1940.

### **Model Designations Accepted from Manufacturer (New Builds)**

XSB2C-2, XSB2C-5, XSB2C-6:

Experimental models.

**SB2C-1:**

The first production model of the Helldiver. The aircraft carried four .50 calibre fixed guns in the wings and twin .30 calibre guns in flexible mount. The SB2C-1 was tested for its torpedo launching capability but never tried to launch any in combat. Was powered by the R-2600-8 engine.

**SB2C-1A:**

A designation used only for procurement of SB2C-1s for the U.S. Army which designated them A-25A with the intention of using them for dive-bombers. There were some structural modifications from the Navy SB2C-1. The Army never used the land-based A-25A in combat, and neither did the Navy and Marine Corps, all of which eventually used the SB2C-1/A-25A for training.

**SB2C-1C:**

Carried two 20 mm fixed guns in the wings and twin .30 calibre guns on a flexible mount. It was powered by the R-2600-8 engine.

**SB2C-3:**

Carried two 20 mm fixed guns in the wings and twin .30 calibres on a flexible mount. It was powered by R-2600-20 engine.

**SB2C-4:**

SB3C-3 with perforated flaps.

**SB2C-4E:**

SB2C-4 with special radar.

**SB2C-5:**

Same as SB2C-4 but with improved pilot's cockpit, two 50 gallon wing tanks, and a strengthened fuselage. Specifications for the SB2C-5 are as follows:

Weights:

Empty	10,589 lbs
Combat	14,415 lbs

Ordnance:

- Two 20 mm wing guns
- Two .30 cal. guns on aft flexible mount
- Eight 5 inch HVAR rockets
- Internal bomb bay that could accommodate up to 1,000 lbs, and two external wing racks that could handle up to 1,000 lbs each.

Wing area	422 sq ft
Wing span	49 ft 9 in

Height        14 ft 9 in  
 Length       36 ft 8 in  
 Power plant   Wright R-2600-20 cyclone

**SBW-1:**  
 SB2C-1 built by Canadian Car and Foundry Co.

**SBW-1B:**  
 Built for the United Kingdom.

**SBW-3:**  
 Similar to SB2C-3.

**SBW-4:**  
 Same as SB2C-4.

**SBW-4E:**  
 Equipped with radar.

**SBW-5:**  
 Same as SB2C-5.

**SBF-1:**  
 SB2C-1 built by Fairchild of Canada.

**SBF-3:**  
 Same as SB2C-3.

**SBF-4E:**  
 Same as SB2C-4E.

**Other Designations**

**SB2C-1E, SB2C-3E, and SB2C-5E:**  
 Equipped with radar.

**SB2C-3P:**  
 Equipped for photographic reconnaissance.

**SB2C-5D:**  
 Equipped for use as a control plane.

**Bureau Numbers**

XSB2C-1	1758
SB2C-1	00001-00004, 00006-00200
SB2C-1A	75218-75588, 76780-76818
SB2C-1C	00201-00370, 01008-01215, (01209-01215 canceled), 18192-18307, 18309-18598
XSB2C-2	00005
SB2C-3	18622-19710
SB2C-3/3E	18599-18619
SB2C-4/4E	19711-21191, 64993-65285, 82858-83126
XSB2C-5	18308, 65286, 83127
SB2C-5	83128-83751, 89120-90019 (89466-90019 canceled)
XSB2C-6	18620-18621
SBF-1	31636-31685
SBF-3	31686-31835
SBF-4E	31836-31935
SBW-1	21192-21231, 60010-60035
SBW-3	21233-21645
SBW-4E	21646-21741, 60036-60209
SBW-5	60210-60459 (60210, 60296-60459 canceled), 21232 (21232 canceled)

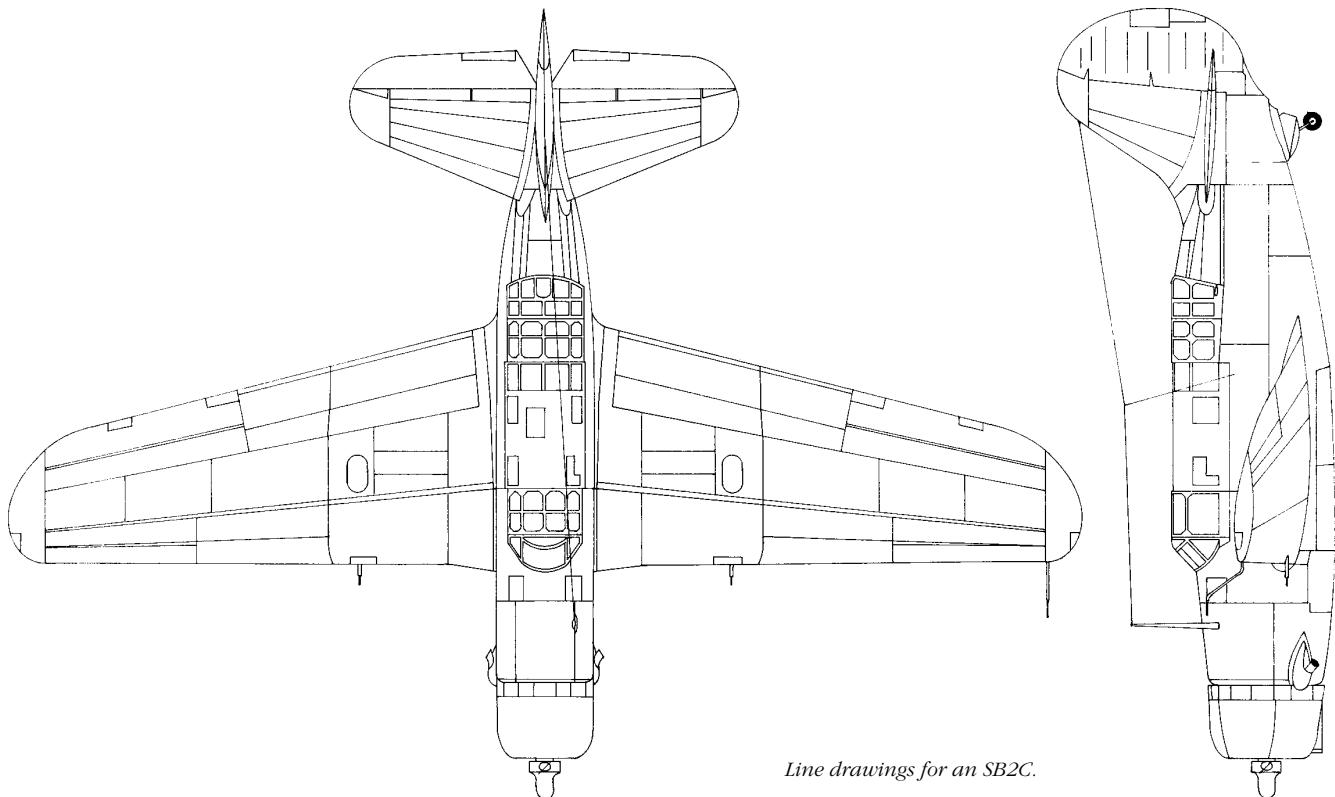

*Line drawings for an SB2C.*

## SB2U Vindicator

Among the first monoplanes to fly from a carrier, the SB2U Vindicator was produced by Vought to provide the Navy with a new dive bomber incorporating the latest aerodynamic developments. The aft portions of the SB2U-1's wings were partially covered with fabric, and the aircraft had some shortcomings such as an uncomfortable cockpit and poor lateral control, but it would prove to be reliable and effective in performing its intended mission.

First contract	11 October 1934
First flight	4 January 1936
First reported in squadron	20 December 1937 by VB-3
Last delivery	July 1941
Last reported in squadron	SB2U-1 by VB-9 on 28 February 1943
Number accepted	170

### Models Accepted from the Manufacturer (New Builds)

**XSB2U-1:**  
Experimental version.

**XSB2U-3:**  
Experimental version.

**SB2U-1:**  
Powered by the Pratt & Whitney 850 hp R-1535-96 engine. Two .30 calibre wing guns, a .30 calibre aft firing gun, carried a 1,000 lb bomb.

**SB2U-2:**  
Same as SB2U-1 but with a higher gross weight.

**SB2U-3:**  
Built for the Marine Corps, the SB2U-3 could operate from a carrier. It had two .50 calibre guns mounted



*An XSB2U-1 Vindicator, May 1936.*

in the cowling and was powered by a Pratt & Whitney R-1535-2 engine. Specifications for the SB2U-3 sea-plane are as follows:

Weights:

Empty	6,153 lbs
Gross	8,900 lbs

Ordnance:

Two .30 cal. wing guns
One .30 cal. flexible gun
One 500 or 1,000 lb bomb

Wing area	305 sq ft
Wing span	41 ft 10 in
Height	16 ft 6 in
Length	37 ft
Power plant	Pratt & Whitney 825 hp R-1535
Max range	1,240 statute miles

### Bureau Numbers

XSB2U-1	9725
SB2U-1	0726-0778
XSB2U-3	0779
SB2U-2	1326-1383
SB2U-3	2044-2100

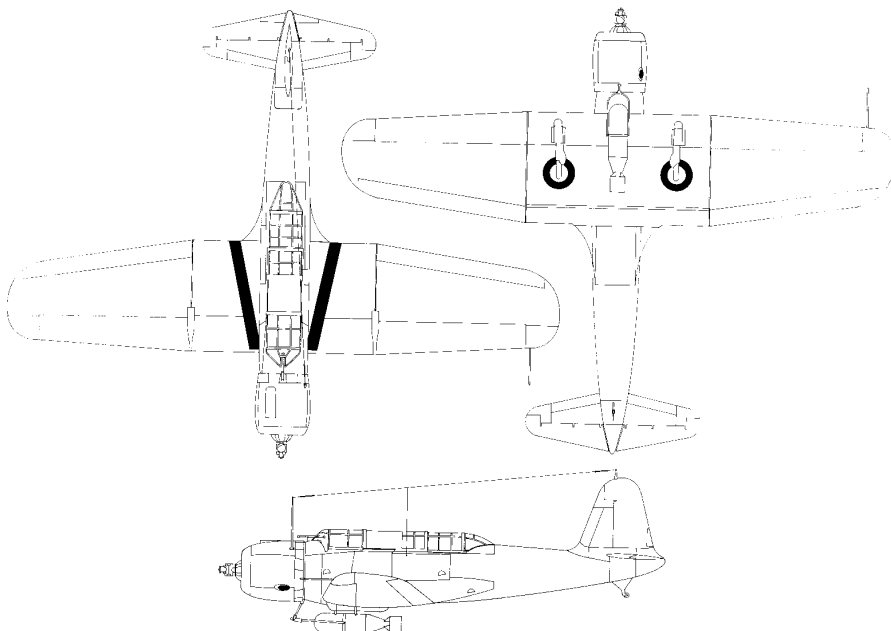

*Line drawings for an SB2U.*

## SBC

A Bureau of Aeronautics contract of 30 June 1932 to the Curtiss Company resulted in the prototype of a fighter aircraft designated XF12C. But before the aircraft was assigned to any fleet squadron, or even put into production, its mission was changed to scout bomber and its designation became SBC-1. Along the way, what had begun life as a monoplane became the last biplane to enter Navy service.

First contract	30 June 1932
First flight	14 June 1934
First reported in squadron	17 July 1937 by VS-5
Last delivery	April 1941
Last reported in squadron	1 June 1943 by VMSB-151 and VC-4
Number accepted	258

### **Models Accepted from the Manufacturer (New Builds)**

**XSBC-3:**  
Experimental article.

**XSBC-4:**  
Experimental article.

**SBC-3:**  
Two crew scout bomber powered by Pratt & Whitney R-1535-94.

**SBC-4:**  
Two crew scout bomber powered by Pratt & Whitney R-1820-94.

Specifications for the SBC-4 are as follows:

Weight:	
Empty	4,841 lbs



*An XSBC-3 in flight, April 1936.*

Gross	7,632 lbs
Dimensions:	
Wing span	34 ft
Length	27 ft 7 in
Ordnance:	
Guns	one forward firing .30 cal. and one flexible .30 cal. gun in rear
Maximum bomb capacity	1,000 lbs

### **Bureau Numbers**

XSBC-3	9225
SBC-3	0507-0589 (0582 modified to XSBC-4)
SBC-4	1268-1325
SBC-4	1474-1504
SBC-4	1809-1843
SBC-4	4199-4248

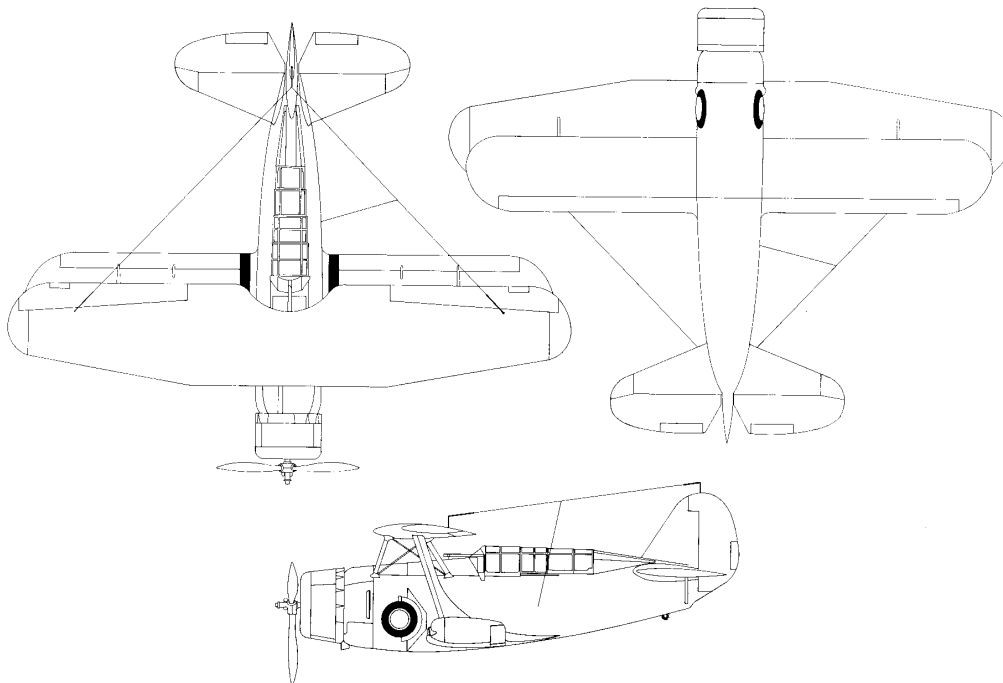

*Line drawings for an SBC-3.*

## SBD Dauntless

Begun by the Northrop Company as the BL-1 and later redesignated BT-2, this aircraft's manufacturer was incorporated into the Douglas Company before the plane was ready for delivery to the Navy. For this reason, it arrived in squadron with the Douglas D in its designation. One of the Navy's most successful combat aircraft, the Dauntless was an indispensable part of the fleet's striking power throughout the Second World War.

Douglas built the aircraft under the designation SBD. The Navy accepted 5,321 SBDs, of which 338 were for Foreign Military Sales. The Navy also accepted 55 BTs from Northrop. The SBD-5 was the most numerous of all the models.

Of all the models accepted from the manufacturer, the differences were in such areas as range, dimensions and engines. For example the SBD-1 had a maximum bombing range of about 860 miles and the SBD-5's was around 1,100. All models were powered by the Wright R-1820. The SBD-1 and the SBD-2 used the R-1820-32; the SBD-3 and the SBD-4 used the R-1820-52; and the SBD-5 used the R-1820-50. The wingspan of 41 feet 6 inches was the same in all models, but the length increased from 32 feet 2 inches in the SBD-1 to 33 feet in the SBD-5.

First contract	11 Nov 1934
First flight	Estimated Aug 1935
First reported in squadron	11 Apr 1938 by VB-5
Last delivery	Aug 1944
Last reported in squadron	SBD-6 on 30 Sep 1945
Number accepted	5,321



*An SBD-3 Dauntless in flight, circa 1941.*

### **Models Accepted from the Manufacturer (New Builds)**

SBD-1	SBD-2	SBD-3
SBD-3A	SBD-4	SBD-4A
SBD-5A	XSBD-6	SBD-6
XBT-1	XBT-2	BT-1

### **SBD-5:**

Specifications for the SBD-5 are as follows:

Weight:

Gross 10,403 lbs

Empty	6,533 lbs
Power Plant	Wright R-1820-60
Dimensions:	
Wing area	325 sq ft
Wing span	41 ft 6 & 5/16 in
Length	33 ft & 1/8 in
Height	13 ft 11 in
Ordnance:	
Guns	two fixed .50 cal. for pilot two free .30 cal. for gunner
Maximum bomb capacity	1,600 lbs



**Bureau Numbers**

SBD-1	1596-1631	SBD-5	10807-11066
SBD-1	1735-1755	SBD-5	28059-28829
SBD-2	2102-2188	XSBD-6	28830
SBD-3	4518-4691	SBD-5	28831-29213
SBD-3	03185-03384	SBD-5	35922-35949
SBD-3	06492-06701	SBD-6	35950
SBD-4	06702-06991	SBD-5	35951-36421
SBD-5A	09693-09752	SBD-5	36433-36932
SBD-4	10317-10806	SBD-5	54050-54599
		SBD-6	54600-55049

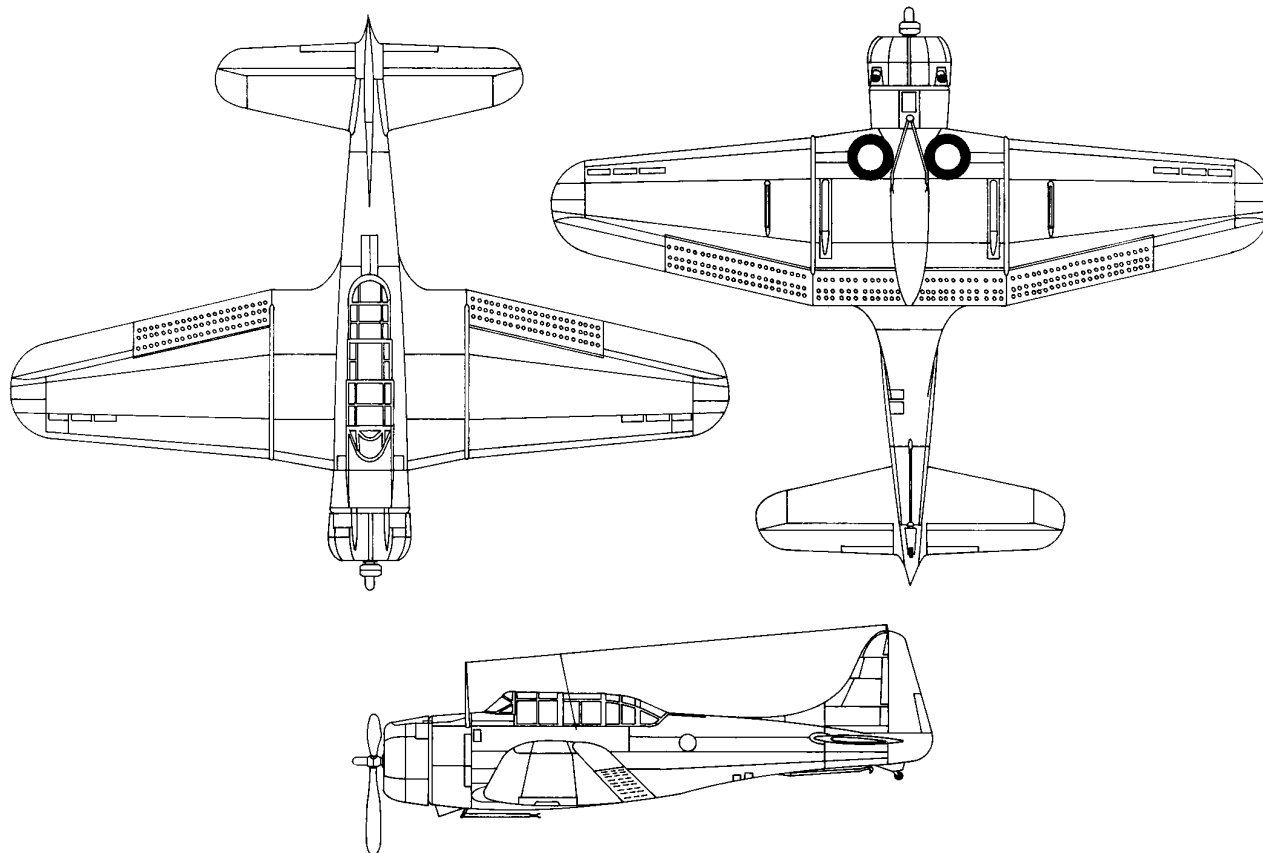

*Line drawings of an SBD.*

## T3J (T-39) Sabreliner

In July 1961, the Navy ordered ten of North American's Model NA-277 to train radar operators. In that order the aircraft was designated T3J-1, but by the time the first one was delivered in 1962, the designation had been changed to T-39D. A total of 52 aircraft were accepted. Characteristics of the T-39 are as follows:

**Crew** Pilot and a copilot as the main student. Provision in aft cabin for an instructor. Two stand-by students and a navigator's station.

**Power Plant** Two Pratt & Whitney 2,400-lb J60-P-3 axial turbojets.

**Mission Range** 1,100 nautical miles

**Weight**

Maximum Takeoff 17,760 lbs

Empty 10,250 lbs

**Dimensions**

Wing Span 44 ft 4 in

Wing Area 342 sq ft

Length 43 ft 8 in

Height 16 ft

**Ordnance:** None

### Bureau Numbers

T-39D 150542-150551, 151336-151347, (151344-151347 canceled), 150969-150992



*A Training Squadron 10 (VT-10) T-39 Sabreliner in flight.*

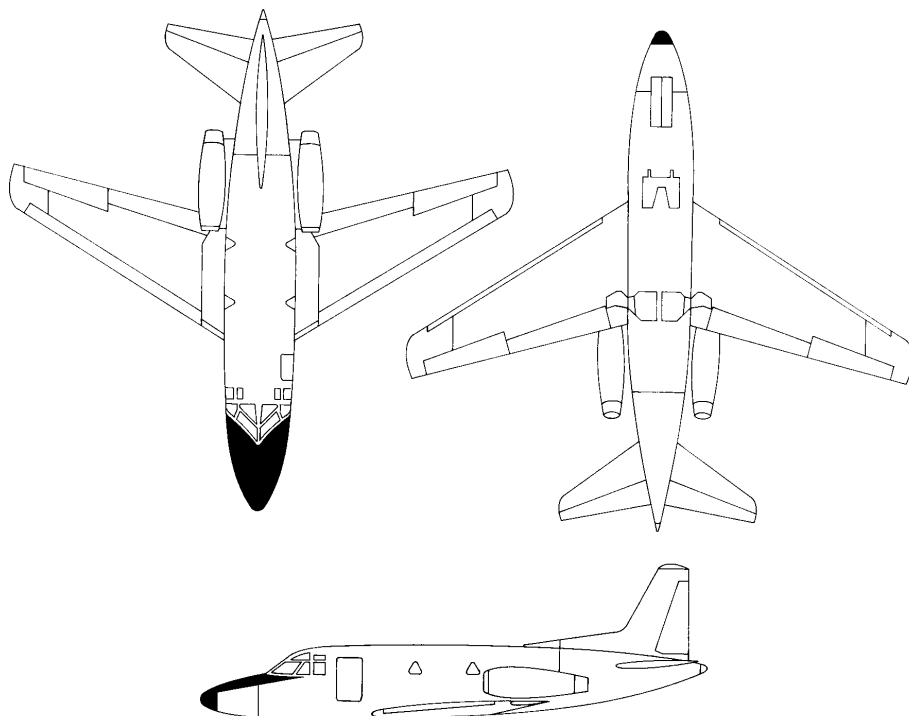

*Line drawings for a T-39.*

## T2D/P2D

Beginning its life as a Bureau of Aeronautics design, this aircraft's prototype was built at the Naval Aircraft Factory and designated the XTN-1. A large twin engine aircraft, its design was the Bureau's response to a need for an improved torpedo bomber. At that time, Rear Admiral William Moffett was Chief of the Bureau of Aeronautics. Moffett championed the existence of the Aircraft Factory for its research and development capability, but he also recognized the need for a strong aviation industry in the United States and accordingly opposed large production runs at the Factory. In keeping with this attitude, BuAer gave the production contract for the XTN-1 to Douglas who produced the aircraft as the T2D.

Built to operate from land and carrier, the T2D-1 ran afoul of the Army who felt the Navy was encroaching upon its purview with a big land-based bomber. In response to complaints, the Navy had Douglas produce the rest of the T2Ds with twin floats and redesignated them P2D for patrol craft.

The aircraft made its first flight on 27 January 1927. It was first reported in squadron by VT-2 on 25 May 1927. The designation last reported in squadron was a P2D-1 by VP-3F on 28 February 1937. A total of thirty aircraft were accepted.

### XT2D-1:

Specifications for the XT2D-1 are as follows:

Span	57 ft.
Height	14 ft 4 1/2 in
Length	44 ft 10 in
Width (wings folded)	26 ft
Full load	9,575 lbs
Useful load	3,715 lbs
Empty weight	5,860 lbs
Landing speed	55 mph

### Bureau Numbers

XTN-1	A7027
T2D-1	A7051-A7053, A7587-A7595
P2D-1	A8644-A8661



*A Douglas T2D-1.*

*Line drawings for a T2D-1.*

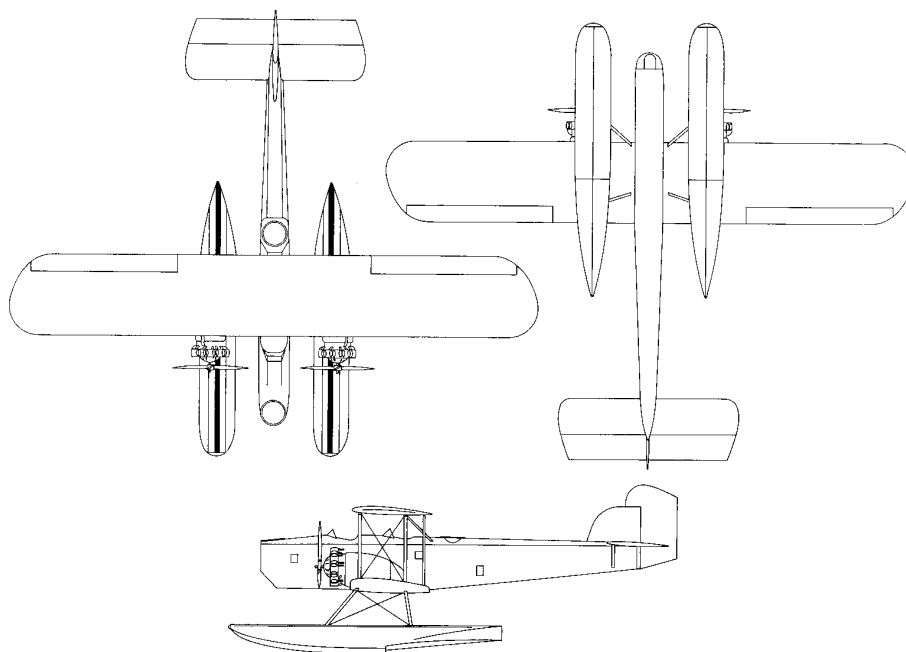

## T3M

The Martin T3M was an improved version of their SC. The Navy contract that ordered it in 1925 was for a torpedo bomber biplane capable of operating with wheels or floats. Martin eventually delivered 123 T3Ms under the designations T3M-1 and T3M-2. Both were three crew: pilot, bombardier and gunner. The T3M-1 was powered by a 575 horsepower Wright T-3 engine and the T3M-2 had a 770 horsepower Packard 3A-2500. In developing the aircraft, the same airframe



An XT3M-3.

and Bureau Number A7224 was used for both the XT3M-1 and XT3M-2.

The date the aircraft first flew is uncertain but is estimated to have done so in July 1926. It was first delivered to squadron on 7 September 1926 to VT-2. It was last reported in squadron when VP-3S reported a T3M-2 on 30 July 1932.

### T3M-1:

Twin float seaplane. Specifications for the T3M-1 are as follows:

Gross weight	9,856 lbs
Empty weight	6,324 lbs
Total useful load	3,532 lbs
Armament	one .30 cal. gun in rear cockpit
Wing Area	848 sq ft
Wing span upper	52 ft 4 in
Wing span lower	56 ft 7 in
Height	16 ft
Length	42 ft 9 in

### Bureau Numbers

T3M-1	A7065-A7078
XT3M-1 & XT3M-2	A7224
T3M-2	A7225-A7322
T3M-2 & XT3M-3	A7323

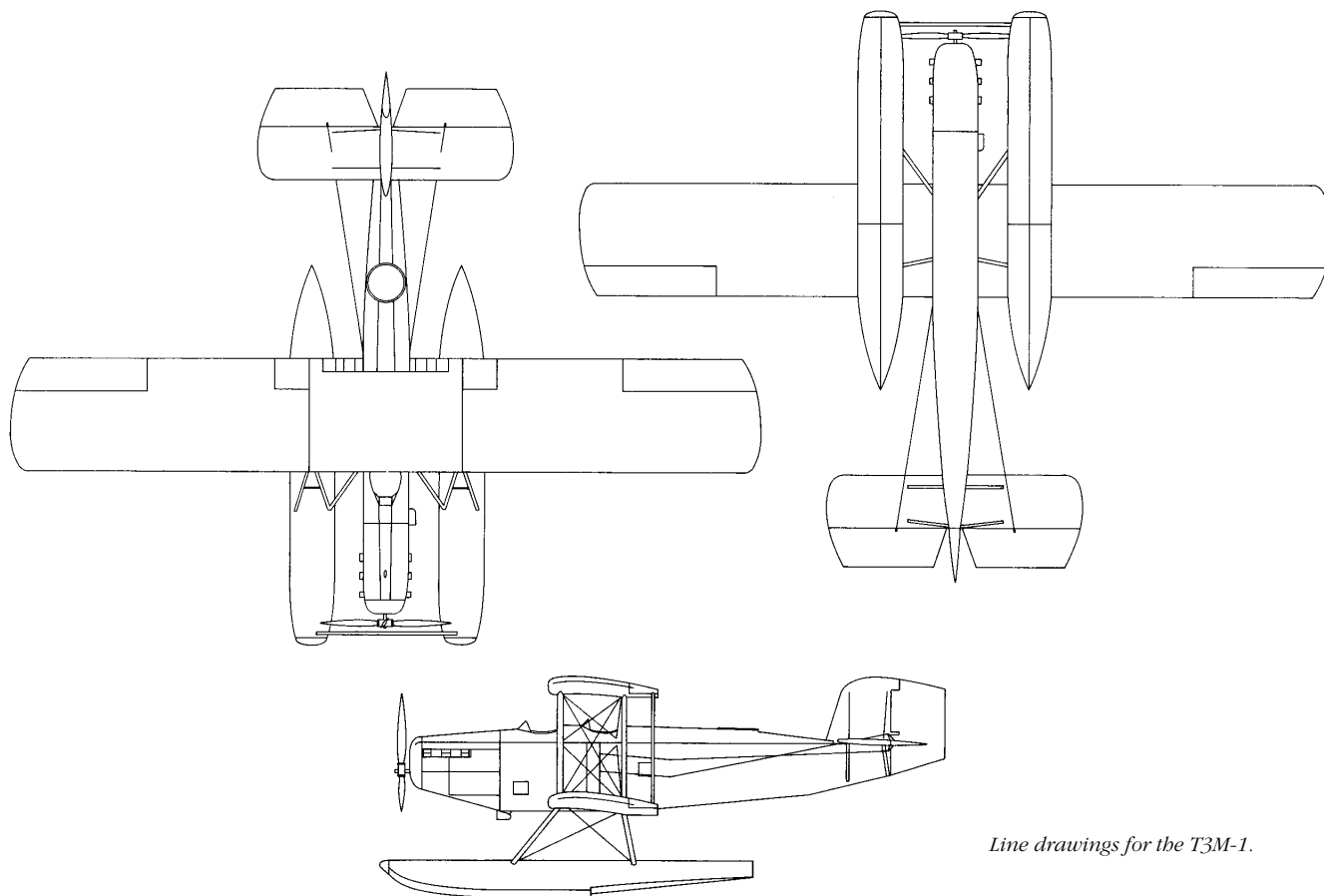

Line drawings for the T3M-1.

## T4M and TG and TE

The earliest model of this aircraft was the Martin (Cleveland) Model 74. Martin designed and developed this torpedo bomber and sold it to the Navy who designated it T4M-1 and later referred to it as the XT4M-1. It was purchased for experimental use to determine the practicality of its type for further production. A production contract of 30 June 1927 ordered 102 T4M-1 aircraft. They were described as single engine, three purpose convertible biplane equipped for catapulting and for deck landing, with emergency floatation gear. The aircraft would be used mainly for carrier operations. It had a crew of three: pilot, bombardier, and gunner. Counting the XT4M-1 and the 102 production planes, Martin delivered 103 aircraft designated T4M.

On 25 June 1929, the Bureau of Aeronautics awarded to the Great Lakes Aircraft Company a contract for

18 aircraft designated TG-1. By June 1929, Great Lakes had taken over Martin's plant at Cleveland. On 2 July 1930, the Navy awarded a contract to the Detroit Aircraft Corporation for 32 TE-1 aircraft which were to be similar to Martin's T4M-1. Detroit subcontracted much of the work on the TE-1 to Great Lakes and soon encountered serious financial difficulties. Eventually Detroit virtually subcontracted to Great Lakes the entire job to build the TE-1s. For this reason, the Navy accepted the TE-1s with Great Lakes data plates and the designation TG-2. Great Lakes delivered a total of 50 aircraft designated TG.

The date of the T4M's first flight is not definitely known but is estimated to have occurred in May 1927. It was first delivered to a squadron on 9 August 1928 and was last delivered in December 1931. The designation last reported was a TG-2 by VT-6 on 31 March 1938.



*A T4M-1 assigned to Naval Air Reserve Base Seattle.*

### T4M-1 (Landplane):

Specifications for the T4M-1 are as follows:

Power plant	525 hp Pratt & Whitney R-1690 (575 hp Wright R-1820 in T4M-2)
Gross weight	6,599 lbs
Empty weight	3,890 lbs

Total useful load	2,709 lbs
Armament	One flexible .30 cal. gun, rear cockpit
Wing area	656 sq ft
Wing span	53 ft both wings
Height	13 ft 5 in
Length	35 ft 7 in

*A TG-1 at Hampton Roads, Virginia, September 1935.*



**TG-1 (Landplane):**

Specifications for the TG-1 are as follows:

Power Plant	Pratt & Whitney R-1690 in TG-1 Pratt & Whitney R-1820 in TG-2
Gross weight	7,652 lbs
Empty weight	4,179 lbs
Total useful load	3,472 lbs
Armament	one flexible .30 cal. gun, rear cockpit
Wing area	656 sq ft

Wing span	53 ft both upper and lower
Height	14 ft 9 in
Length	34 ft 8 in

**Bureau Numbers**

XT4M-1	A7566
T4M-1	A7852-A7899, A7596-A7649
TG-1	A8458-A8475
TG-2	A8697-A8728

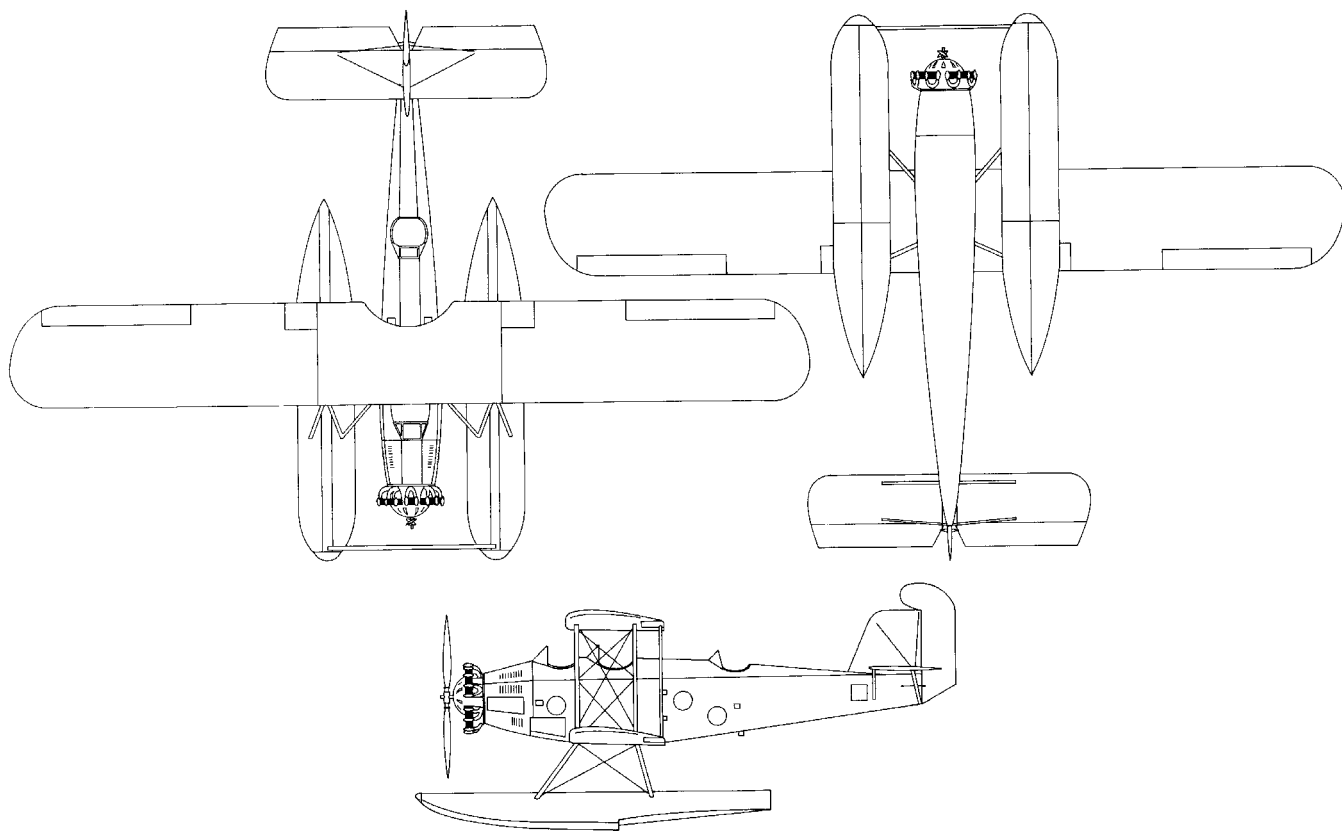

*Line drawings for the T4M-1.*

**TB**

The Boeing Company built this single engine amphibious float plane to Bureau of Aeronautics Design Number 35. Only three were produced and all of them were delivered to the Navy during 1927. Powered by a 720 horsepower Packard 1A-2500, this large biplane, had a crew of three and, as a float plane, could carry up to 1,968 pounds of ordnance. The TBs were similar to the Martin T3M aircraft.

**TB-1:**

Specifications for the TB-1 are as follows:

Crew            three

Length	42 ft 7 in
Height	15 ft
Span	55 ft both wings
Wing area	868.4 sq ft
Weights	
gross	10,703 lbs
useful	4,405 lbs
Range	about 340 nautical miles at full speed

***Bureau Numbers***

TB-1            A7024-A7026



*An XTB-1, Boeing's version of the Martin T3M.*

## TBD Devastator

In 1934 the Navy conducted a competition for a new carrier-based torpedo bomber. Great Lakes submitted a design for a biplane, Douglas for a monoplane. The Great Lakes' design was built as the TBG-1. The design which Douglas was invited to reduce to practice, first flew on 15 April 1935 and became the Navy's initial carrier-based monoplane, the TBD Devastator. The first delivery occurred on 5 October 1937. The last delivery was in November 1939. The aircraft was last reported in squadron on 31 August 1942. A total of 130 aircraft were accepted.



*The XTBD-1 Devastator.*

### *Models Accepted from the Manufacturer (New Builds)*

**XTBD-1:**

Experimental version of the Douglas design.

**TBD-1:**

Production version of the XTBD-1. It was a horizontal bomber, three-place, carrier-based aircraft. Specifications for the TBD-1 are as follows:

Maximum gross weight 10,261 lbs  
 Maximum fuel weight 1,080 lbs  
 Maximum speed 221 mph at 8,000 ft  
 Maximum range 1,080 statute miles

**Armament:**

One .30 cal. synchronized gun (500 rounds)  
 One .30 cal. flexible gun (600 rounds)  
 Up to 1,500 pounds of bombs or up to a 1,850 pound torpedo

Engine one 900 hp Pratt & Whitney R-1930-64

Wing span 50 ft (folded, 25 ft 8 1/2 in)  
 Length 35 ft

### **Other Designations**

**TBD-1A:**

Twin float landing gear added by the Naval Aircraft Factory.

### **Bureau Numbers**

XTBD-1 9720  
 TBD-1 0268-0381  
 TBD-1 1505-1519

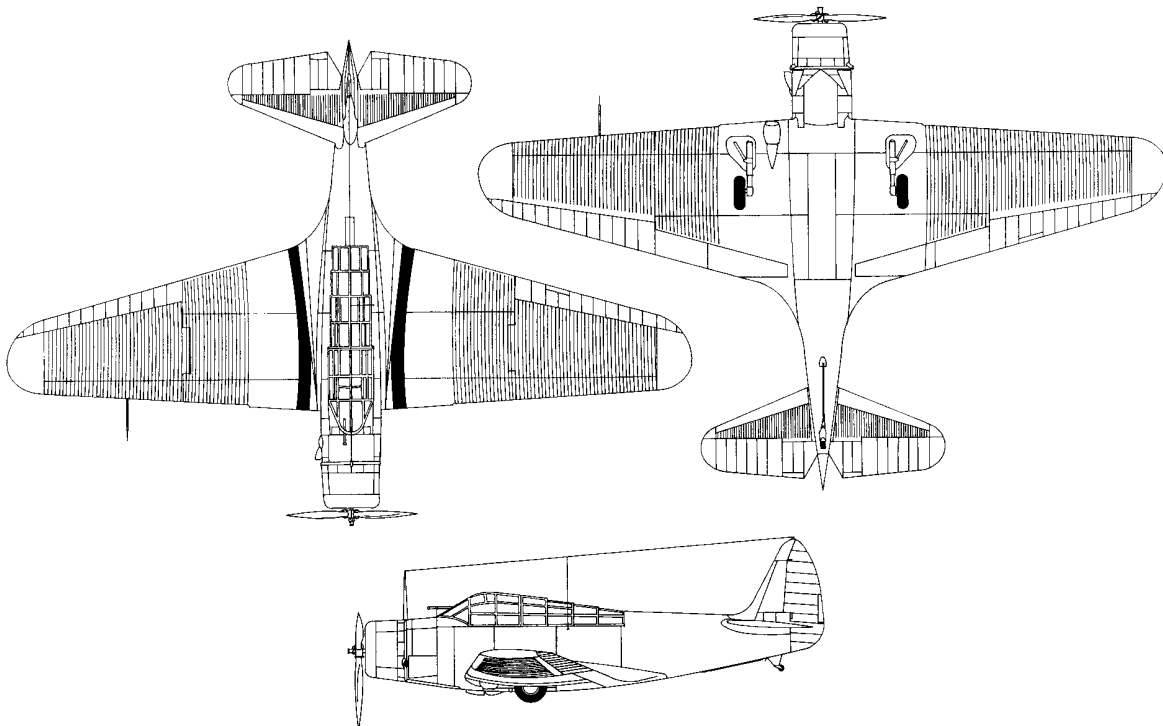

*Line drawings for the TBD-1.*



## TBF/TBM Avenger

Among the Grumman Company's outstanding contributions to naval aviation, the Avenger perhaps holds the honor of being the most versatile. It was in squadron from March 1942 until October 1954, a shorter time than some other aircraft, but during those years it served as a torpedo bomber, an ASW aircraft, and the Navy's first carrier-based AEW plane; there was also a modification for night operations, one for radar countermeasures, and another for Carrier Onboard Delivery.

The contract of 8 April 1940 which the Navy awarded to Grumman was for the company's first attack aircraft. Until that time, Grumman's work for the Navy had been entirely with fighters. The first flight of the mid-wing monoplane, three-place, torpedo bomber occurred on 7 August 1941. During the Second World War, the Avenger was produced by Grumman as the TBF and by the Eastern Aircraft Division of General Motors as the TBM. Grumman produced a total of 2,290 aircraft, Eastern produced 7,546 aircraft. The last delivery to the Navy was made in September 1945.

The TBF-1 could carry up to 2,000 pounds of torpedoes or bombs in the bomb bay. It had a dorsal turret with a .50 calibre gun at the after end of the cockpit, a forward-firing .30 calibre gun at the nose cowling and another .30 calibre gun located ventrally facing aft.

The TBF-1 was powered by a single 1700 horsepower Wright R-2600-8 engine.

The XTBF-3 was developed to provide the Avenger with the 1900 horsepower Wright 2600-20 engine. The production version of the XTBF-3 was never produced in its F designation but was built by Eastern as the TBM-3. The TBM-3's range was from 1,130 to 2,530 statute miles and an average speed of 150 mph.

The TBM-3 had a length of 40 feet 11½ inches, a height of 16 feet 9 inches. The wing span was 54 feet 2 inches (folded size was 19 feet).

### ***Model Designations Accepted from Manufacturer (New Builds)***

**XTBF-1:**

Experimental version of design.

**TBF-1:**

Production version of XTBF-1.

**TBF-1B:**

TBF-1 diverted from Navy delivery.

**TBF-1C:**

Same as TBF-1 but with provision for two .50 cal. wing guns.

**XTBF-2:**

Test bed for Wright experimental R-2600-10 engine.



*A TBF-1 in flight.*

**XTBF-3:**  
Experimental version with Wright R-2600-20 engine.

**TBM-1:**  
Built to same specifications as the TBF-1.

**TBM-1C:**  
Same as TBF-1C.

**XTBM-3:**  
Experimental version with Wright R-2600-20 engine.

**TBM-3:**  
Production development of the XTBF-3 which was similar to the TBF-1 but with improved engine, 1900 hp Wright R-2600-20.

**TBM-3E:**  
TBM-3 equipped with ASW radar.

**XTBM-4:**  
TBM-3 with structural strength increased to withstand 5Gs.

**Other Designations**

**TBF-1CP:**  
Same as the TBF-1C but equipped with trimetrogon camera for photo reconnaissance.

**TBF-1D:**  
Same as TBF-1C except for special radio and radar installation.

**TBF-1E:**  
Same as TBF-1C but equipped with special radar.

**TBF-1J:**  
TBF-1 converted to utility plane.

**TBF-1L:**  
The TBF-1, TBF-1C, TBF-1D, TBF-1E but equipped with searchlight mounted in bomb bay.

**TBM-1CP:**  
Same as TBM-1C but equipped with trimetrogon camera for photo reconnaissance.

**TBM-1D:**  
Same as TBF-1D.

**TBM-1E:**  
Same as TBM-1C but equipped with special radar.

**TBM-1J:**  
TBM-1 converted to utility plane.

**TBM-1L:**  
TBF-1C, TBF-1D, or TBF-1E but equipped with searchlight mounted in the bomb bay.

**TBM-3D:**  
Same as TBM-3 but equipped with special radar.

**TBM-3E:**  
Same as TBM-3 but equipped with special radar (APS-4).

**TBM-3J:**  
TBM-3 converted to utility plane.

**TBM-3L:**  
Same as TBM-3 but with searchlight mounted in bombay.

**TBM-3N:**  
TBM-3 equipped for night operations (all-weather).

**TBM-3P:**  
Same as TBM-3 but with trimetrogon camera for photo reconnaissance.

**TBM-3Q:**  
TBM-3 equipped for ECM missions.

**TBM-3R:**  
COD version TBM-3.

**TBM-3S:**  
ASW version of the TBM-3E.

**TBM-3S2:**  
Same as TBM-3S with improved ASW equipment and rearrangement of the after crew space.

**TBM-3U:**  
Utility version of TBM-3E.

**TBM-3W:**  
Same as TBM-3 but equipped as a special radar search plane.

**TBM-3W2:**  
TBM-3W with improved ASW equipment and rearrangement of the after crew space with APS-20 radar.

**Bureau Numbers**

XTBF-1	2539-2540
TBF-1	00373-00392
XTBF-2	00393
TBF-1	00394-00658
TBF-1	01731-01770
TBF-1	05877-06491
TBM-1C	16792-17019
TBF-1	23857-24140
XTBF-3	24141
TBF-1	24142-24340
XTBF-3	24341
TBF-1	24342-24520
TBM-1	24521-25070
TBM-1C	25071-25174
XTBM-3	25175
TBM-1C	25176-25520
XTBM-3	25521
TBM-1C	25522-25699
XTBM-3	25700
TBM-1C	25701-25720
TBM-1C	34102-34105
TBM-1C	45445-45644
XTBM-3	45645
TBM-1C	45646-46444

TBF-1	47438-47637	TBM-3E	91107-92006 (Deliveries of 91753-92006 canceled)
TBF-1C	47638-48123	TBM-3	97532-97672 (Deliveries canceled)
TBM-3E	53050-53949	XTBM-4	97673-97675
TBM-3	68062-69538	TBM-4	97676-98601 (Deliveries canceled)
TBM-1C	73117-73498	TBM-4	102576-104575 (Deliveries canceled)
TBM-3E	85459-86296 (Deliveries of 86293-86296 canceled)	TBM-4	117729-118928 (Deliveries canceled)

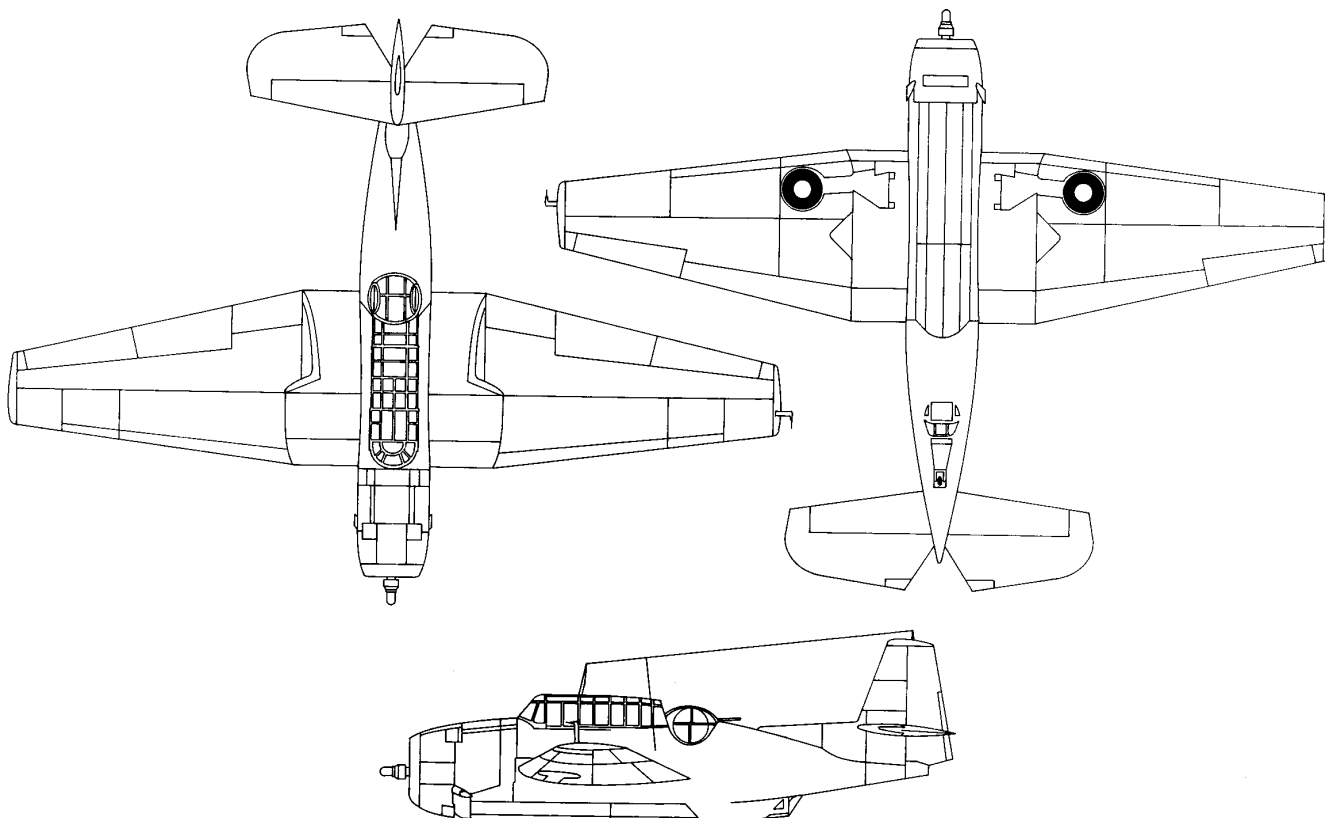

*Line drawing for a TBF-1.*

## TBY Seawolf

Although Vought designed and built the prototype of the TBY, and Consolidated built 180 production aircraft, the Seawolf never served operationally. Vought designed the torpedo bomber on a Navy contract awarded 22 April 1940, but heavy production orders led both the Navy and the firm to conclude that another manufacturer should build the aircraft in quantity. Consolidated received an order for 1,100 planes, but

built only 180 before the order was canceled. The lone Vought aircraft was designated XTBU-1. The Consolidated version was designated TBY-2.

First flight 22 December 1941  
 Last reported in squadron A TBY-2 on 31 Aug 1945

### TBY-2:

Specifications for the TBY-2 are as follows:

Weight	
Gross	17,491–18,940 lbs
Empty	11,366 lbs
Wing span	56 ft 11 5/32 in
Wing area	440 sq ft
Height	18 ft 6 1/2 in
Length	39 ft 2 1/4 in
Ordnance:	
Guns	three fixed .50 cal. with 640 rounds
	one flexible .50 cal. with 400 rounds
	one flexible .30 cal. with 500 rounds
Bomb capacity	2,000 lbs internal
	2,000 lbs external

### Bureau Numbers

TBY-2	30299-31398 (30368-30370 canceled)
TBY-2	30481-31398 (all canceled)
TBY-2	30369



*A flight of TBYS, July 1945.*

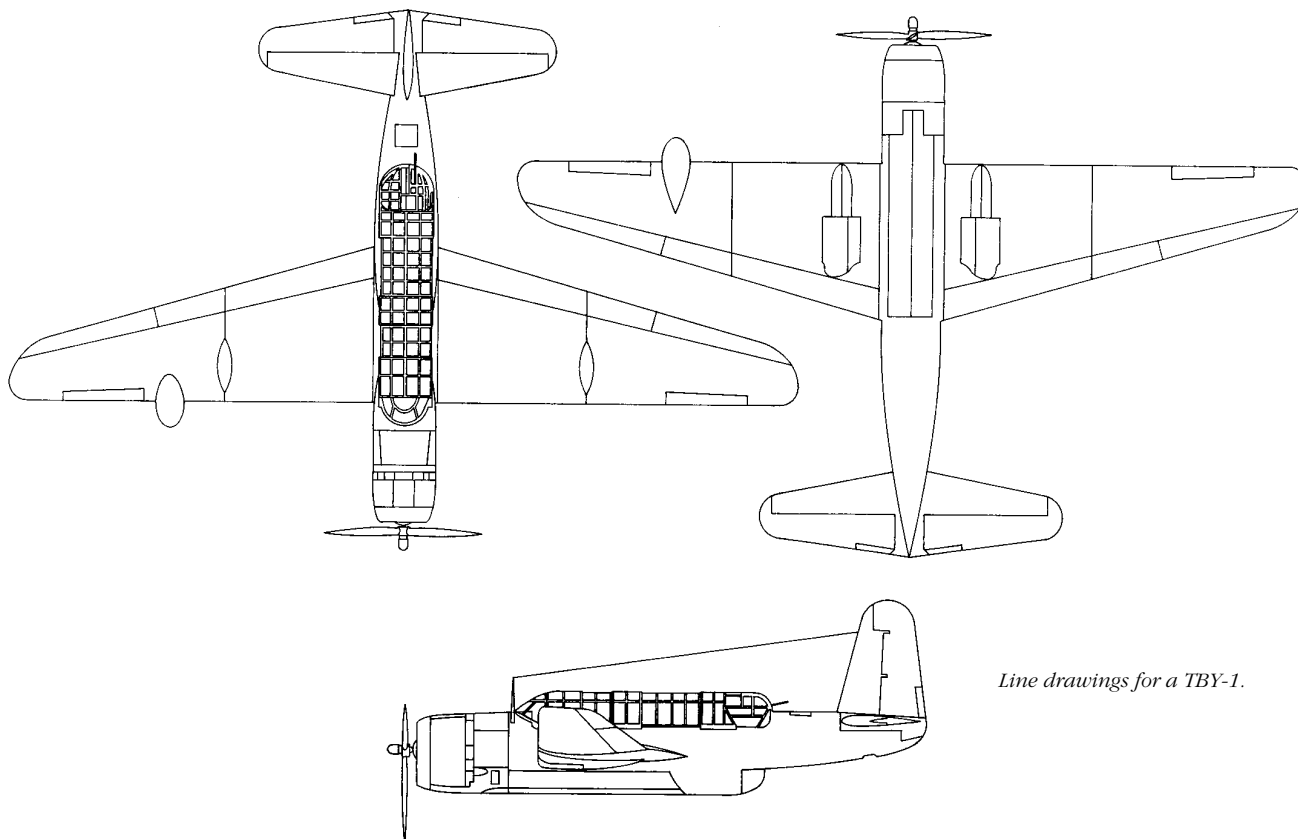

*Line drawings for a TBY-1.*

## TC-4C Academe

In December 1966, the Navy ordered nine Grumman Gulfstream I aircraft converted to train the bombardier navigator for the A-6 Intruder. Deliveries of the TC-4C Academe began in October 1967 and were completed in May 1968. Characteristics of the TC-4C are as follows:

Power Plant	Two 11,400 lb Rolls Royce Spey MK 511-8 turbofans.
Maximum Range	3,045 nautical miles

Weight	
Maximum Takeoff	57,500 lbs
Dimensions	
Wing Span	69 ft 10 in
Wing Area	793.5 sq ft
Length	79 ft 11 in
Height	24 ft 6 in
Ordnance:	None

### Bureau Numbers

TC-4C	155722-155730
-------	---------------



*A TC-4C Academe in flight.*

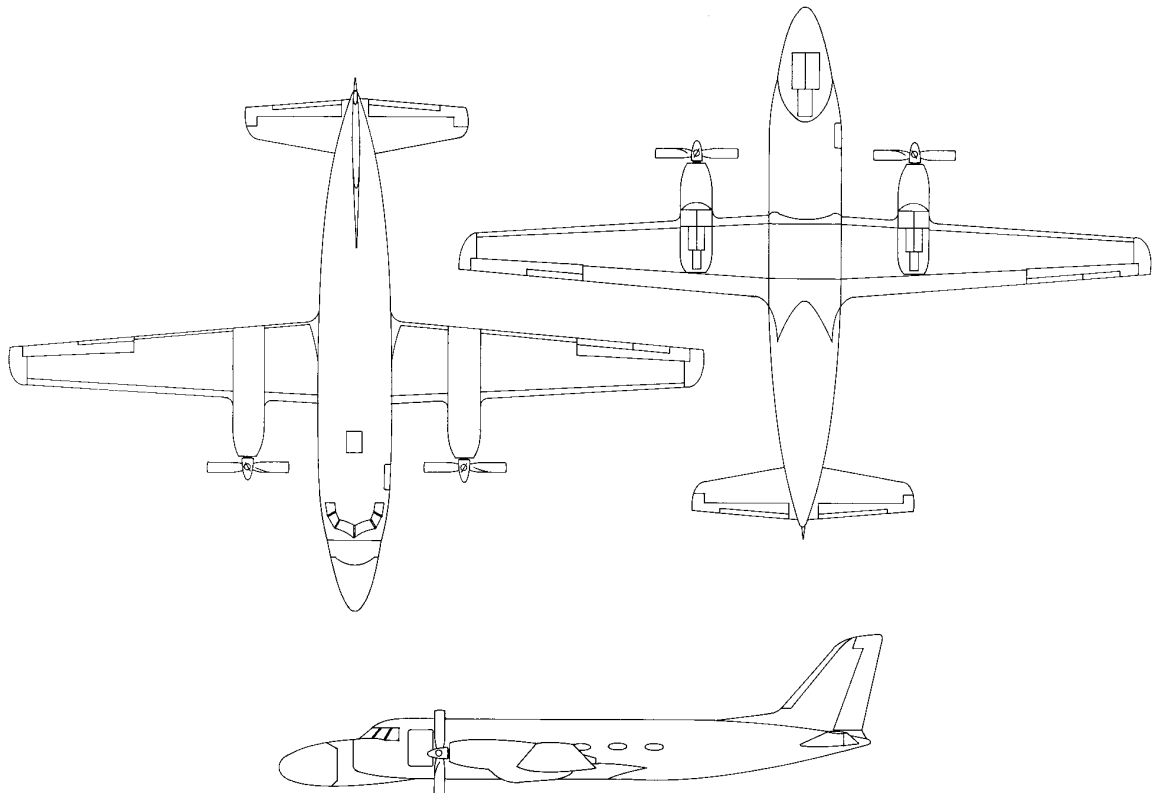

*Line drawings  
for a TC-4C.*

## APPENDIX 2

# Aircraft Carrier Listing for CV, CVB, CVA, CVAN, CVN, CVL, and CVE Designations

**T**HE CVB AND CVL designations were established within the original CV designation on 15 July 1943. CVA replaced CV and CVB on 1 October 1952; CVL went out of use on 15 May 1959. CV and CVN replaced CVA and CVAN on 30 June 1975 to designate the multimission character of aircraft carriers after the decommissioning of the last CVS in 1974.

During World War II (7 December 1941 to 2 September 1945) the Navy operated 110 carriers (includes those designated CV, CVE and CVL). It commissioned 102 carriers (includes those designated CV, CVE and CVL) during the above mentioned time frame.

Original Classes—Of the first 7 ships, *Langley*, *Ranger*, and *Wasp* were single types, *Lexington* and *Saratoga* were sisters as were *Yorktown*, *Enterprise* and *Hornet*.

*Essex* Class—24 ships; CV-9 through 21, 31 through 35, 37 through 40, 45, and 47. Of these numbers, 14, 15, 19, 21, 32–34, 36–40, 45 and 47 are sometimes referred to as “Long-Hull” *Essex* class.

*Independence* Class—9 ships, CVL 22 through 30.

*Midway* Class—3 ships, CVB 41 through 43.

*Saipan* Class—2 ships, CVL 48 and 49.

*Enterprise* Class—1 ship, CVAN 65.

*Forrestal* Class—4 ships, CVA 59 through 62.

*Kitty Hawk* Class—4 ships, CVA 63, 64, 66 and 67.

*Nimitz* Class—8 ships, CVN 68 through 75.

### Carrier Listing for CV, CVA, CVB, CVAN, CVN, and CVL

Hull No. Name	Date of commission and decommission, loss, stricken or transfer	Designations	Date of Designation Change
1 <i>Langley</i>	20 Mar 1922	CV 1	
	27 Feb 1942	AV 3	21 Apr 1937
2 <i>Lexington</i>	14 Dec 1927	CV 2	
	8 May 1942		
3 <i>Saratoga</i>	16 Nov 1927	CV 3	
	26 Jul 1946		
4 <i>Ranger</i>	4 Jun 1934	CV 4	
	31 Jan 1947		
5 <i>Yorktown</i>	30 Sep 1937	CV 5	
	7 Jun 1942		

### Carrier Listing for CV, CVA, CVB, CVAN, CVN, and CVL—Continued

Hull No. Name	Date of commission and decommission, loss, stricken or transfer	Designations	Date of Designation Change
6 <i>Enterprise</i>	12 May 1938	CV 6	
	1 Jul 1958	CVA 6	1 Oct 1952
		CVS 6	8 Aug 1953
7 <i>Wasp</i>	25 Apr 1940	CV 7	
	15 Sep 1942		
8 <i>Hornet</i>	20 Oct 1941	CV 8	
	26 Oct 1942		
9 <i>Essex</i>	31 Dec 1942	CV 9	
	1 Jun 1973	CVA 9	1 Oct 1952
		CVS 9	8 Mar 1960
10 <i>Yorktown</i>	15 Apr 1943	CV 10	
	1 Jun 1973	CVA 10	1 Oct 1952
		CVS 10	1 Sep 1957
11 <i>Intrepid</i>	16 Aug 1943	CV 11	
	15 Mar 1974	CVA 11	1 Oct 1952
		CVS 11	31 Mar 1962
12 <i>Hornet</i>	29 Nov 1943	CV 12	
	26 May 1970	CVA 12	1 Oct 1952
		CVS 12	27 Jun 1958
13 <i>Franklin</i>	31 Jan 1944	CV 13	
	13 Feb 1969	CVA 13	1 Oct 1952
		CVS 13	8 Aug 1953
14 <i>Ticonderoga</i>	8 May 1944	CV 14	
	16 Nov 1973	CVA 14	1 Oct 1952
15 <i>Randolph</i>	9 Oct 1944	CV 15	
	13 Feb 1969	CVA 15	1 Oct 1952
		CVS 15	31 Mar 1959
16 <i>Lexington</i>	17 Feb 1943	CV 16	
	8 Nov 1991	CVA 16	1 Oct 1952
		CVS 16	1 Oct 1962
		CVT 16	1 Jan 1969
		AVT 16	1 Jul 1978
17 <i>Bunker Hill</i>	25 May 1943	CV 17	
	1 Nov 1966	CVA 17	1 Oct 1952
		CVS 17	8 Aug 1953
18 <i>Wasp</i>	24 Nov 1943	CV 18	
	1 Jul 1972	CVA 18	1 Oct 1952
		CVS 18	1 Nov 1956
19 <i>Hancock</i>	15 Apr 1944	CV 19	
	30 Jan 1976	CVA 19	1 Oct 1952
20 <i>Bennington</i>	6 Aug 1944	CV 20	

**Carrier Listing for CV, CVA, CVB, CVAN,  
CVN, and CVL—Continued**

Hull No. Name	Date of commission and decommission, loss, stricken or transfer	Designations	Date of Designation Change
	15 Jan 1970	CVA 20	1 Oct 1952
21 <i>Boxer</i>	16 Apr 1945	CVS 20	30 Jun 1959
	1 Dec 1969	CV 21	
		CVA 21	1 Oct 1952
		CVS 21	1 Feb 1956
22 <i>Independence</i>	14 Jan 1943	CVL 22	
	29 Jan 1951		
23 <i>Princeton</i>	25 Feb 1943	CVL 23	
	24 Oct 1944		
24 <i>Belleau Wood</i>	31 Mar 1943	CVL 24	
	1 Oct 1960		
25 <i>Coupens</i>	28 May 1943	CVL 25	
	1 Nov 1959	AVT 1	15 May 1959
26 <i>Monterey</i>	17 Jun 1943	CVL 26	
	1 Jun 1970	AVT 2	15 May 1959
27 <i>Langley</i>	31 Aug 1943	CVL 27	
	6 Jun 1951		
28 <i>Cabot</i>	24 Jul 1943	CVL 28	
	1 Nov 1959	AVT 3	15 May 1959
29 <i>Bataan</i>	17 Nov 1943	CVL 29	
	1 Sep 1959	AVT 4	15 May 1959
30 <i>San Jacinto</i>	15 Dec 1943	CVL 30	
	1 Jun 1970	AVT 5	15 May 1959
31 <i>Bon Homme Richard</i>	26 Nov 1944	CV 31	
	2 Jul 1971	CVA 31	1 Oct 1952
32 <i>Leyte</i>	11 Apr 1946	CV 32	
	1 Jun 1969	CVA 32	1 Oct 1952
		CVS 32	8 Aug 1953
33 <i>Kearsarge</i>	2 Mar 1946	CV 33	
	15 Jan 1970	CVA 33	1 Oct 1952
		CVS 33	1 Oct 1958
34 <i>Oriskany</i>	25 Sep 1950	CV 34	
	20 Sep 1976	CVA 34	1 Oct 1952
		CV 34	30 Jun 1975
36 <i>Antietam</i>	28 Jan 1945	CV 36	
	1 May 1973	CVA 36	1 Oct 1952
		CVS 36	8 Aug 1953
37 <i>Princeton</i>	26 Nov 1945	CV 37	
	30 Jan 1970	CVA 37	1 Oct 1952
		CVS 37	1 Jan 1954
		LPH 5	2 Mar 1959
38 <i>Shangri-La</i>	15 Sep 1944	CV 38	
	15 Jul 1982	CVA 38	1 Oct 1952
		CVS 38	30 Jun 1969
39 <i>Lake Champlain</i>	3 Jun 1945	CV 39	
	1 Dec 1969	CVA 39	1 Oct 1952
		CVS 39	1 Aug 1957
40 <i>Tarawa</i>	8 Dec 1945	CV 40	
	1 Jun 1967	CVA 40	1 Oct 1952
		CVS 40	10 Jan 1955
		AVT 12	17 Apr 1961
41 <i>Midway</i>	10 Sep 1945	CVB 41	
	11 Apr 1992	CVA 41	1 Oct 1952
		CV 41	30 Jun 1975

**Carrier Listing for CV, CVA, CVB, CVAN,  
CVN, and CVL—Continued**

Hull No. Name	Date of commission and decommission, loss, stricken or transfer	Designations	Date of Designation Change
42 <i>Franklin D. Roosevelt</i>	27 Oct 1945	CVB 42	
	1 Oct 1977	CVA 42	1 Oct 1952
		CV 42	30 Jun 1975
43 <i>Coral Sea</i>	1 Oct 1947	CVB 43	
	26 Apr 1990	CVA 43	1 Oct 1952
		CV 43	30 Jun 1975
45 <i>Valley Forge</i>	3 Nov 1946	CV 45	
	15 Jan 1970	CVA 45	1 Oct 1952
		CVS 45	1 Jan 1954
		LPH 8	1 Jul 1961
47 <i>Philippine Sea</i>	11 May 1946	CV 47	
	1 Dec 1969	CVA 47	1 Oct 1952
		CVS 47	15 Nov 1955
		AVT 11	15 May 1959
48 <i>Saipan</i>	14 Jul 1946	CVL 48	
	14 Jan 1970	AVT 6	15 May 1959
		AGMR 2	8 Apr 1965
49 <i>Wright</i>	6 Feb 1947	CVL 49	
	22 May 1970	AVT 7	15 May 1959
		CC 2	11 May 1963
59 <i>Forrestal</i>	1 Oct 1955	CVA 59	
	30 Sep 1993	CV 59	30 Jun 1975
		AVT 59	4 Feb 1992
60 <i>Saratoga</i>	14 Apr 1956	CVA 60	
	20 Aug 1994	CV 60	30 Jun 1972
61 <i>Ranger</i>	10 Aug 1957	CVA 61	
	10 Jul 1993	CV 61	30 Jun 1975
62 <i>Independence</i>	10 Jan 1959	CVA 62	
		CV 62	28 Feb 1973
63 <i>Kitty Hawk</i>	29 Apr 1961	CVA 63	
		CV 63	29 Apr 1973
64 <i>Constellation</i>	27 Oct 1961	CVA 64	
		CV 64	30 Jun 1975
65 <i>Enterprise</i>	24 Nov 1961	CVAN 65	
		CVN 65	30 Jun 1975
66 <i>America</i>	23 Jan 1965	CVA 66	
		CV 66	30 Jun 1975
67 <i>John F. Kennedy</i>	7 Sep 1968	CVA 67	
		CV 67	29 Apr 1973
68 <i>Nimitz</i>	3 May 1975	CVAN 68	
		CVN 68	30 Jun 1975
69 <i>Dwight D. Eisenhower</i>	18 Oct 1977	CVN 69	
70 <i>Carl Vinson</i>	13 Mar 1982	CVN 70	
71 <i>Theodore Roosevelt</i>	25 Oct 1986	CVN 71	
72 <i>Abraham Lincoln</i>	11 Nov 1989	CVN 72	
73 <i>George Washington</i>	4 Jul 1992	CVN 73	
74 <i>John C. Stennis</i>			
75 <i>United States</i>			

**Carrier Listing for CVE Designations**

The original escort carrier designation AVG changed to ACV on 20 August 1942 and to CVE on 15 July 1943. The CVE designation went out of use when the remaining escort carriers were reclassified AKV (Aircraft Ferry) on 7 May 1959.

Hull No. Name	Date of commission and decommission, loss, stricken or transfer	Designations	Date of Change
1 <i>Long Island</i>	2 Jun 1941 12 Apr 1946		
9 <i>Bogue</i>	26 Sep 1942 1 Mar 1959	CVHE 9	12 Jun 1955
11 <i>Card</i>	8 Nov 1942 15 Sep 1970	CVHE 11 CVU 11 AKV 40	12 Jun 1955 1 Jun 1959 7 May 1959
12 <i>Copabee</i>	15 Jun 1942 1 Mar 1959	CVHE 12	12 Jun 1955
13 <i>Core</i>	10 Dec 1942 15 Sep 1970	CVHE 13 CVU 13 AKV 41	12 Jun 1955 1 Jul 1958 7 May 1959
16 <i>Nassau</i>	20 Aug 1942 1 Mar 1959	CVHE 16	12 Jun 1955
18 <i>Altamaha</i>	15 Sep 1942 1 Mar 1959	CVHE 18	12 Jun 1955
20 <i>Barnes</i>	20 Feb 1943 1 Mar 1959	CVHE 20	12 Jun 1955
21 <i>Block Island</i>	8 Mar 1943 29 May 1944		
23 <i>Breton</i>	12 Apr 1943 6 Aug 1971	CVHE 23 CVU 23 AKV 42	12 Jun 1955 1 Jul 1958 7 May 1959
25 <i>Croatan</i>	28 Apr 1943 15 Sep 1970	CVHE 25 CVU 25 AKV 43	12 Jun 1955 1 Jul 1958 7 May 1959
26 <i>Sangamon</i>	25 Aug 1942 1 Nov 1945		
27 <i>Suwannee</i>	24 Sep 1942 1 Mar 1959	CVHE 27	12 Jun 1955
28 <i>Chenango</i>	19 Sep 1942 1 Mar 1959	CVHE 28	12 Jun 1955
29 <i>Santee</i>	24 Aug 1942 1 Mar 1959	CVHE 29	12 Jun 1955
30 <i>Charger</i>	3 Mar 1942 29 Mar 1946		
31 <i>Prince William</i>	9 Apr 1943 1 Mar 1959	CVHE 31	12 Jun 1955
55 <i>Casablanca</i>	8 Jul 1943 23 Apr 1947		
56 <i>Liscome Bay</i>	7 Aug 1943 24 Nov 1943		
57 <i>Anzio</i> ( <i>ex-Coral Sea</i> )	27 Aug 1943 1 Mar 1959	CVHE 57	12 Jun 1955
58 <i>Corregidor</i>	31 Aug 1943 1 Oct 1958	CVU 58	12 Jun 1955
59 <i>Mission Bay</i>	13 Sep 1943 1 Sep 1958	CVU 59	12 Jun 1955

**Carrier Listing for CVE Designations—Continued**

Hull No. Name	Date of commission and decommission, loss, stricken or transfer	Designations	Date of Change
60 <i>Guadalcanal</i>	25 Sep 1943 27 May 1958	CVU 60	12 Jun 1955
61 <i>Manila Bay</i>	5 Oct 1943 27 May 1958	CVU 61	12 Jun 1955
62 <i>Natoma Bay</i>	14 Oct 1943 27 May 1958	CVU 62	12 Jun 1955
63 <i>St. Lo</i> ( <i>ex-Midway</i> )	23 Oct 1943 25 Oct 1944		
64 <i>Tripoli</i>	31 Oct 1943 1 Feb 1959	CVU 64	12 Jun 1955
65 <i>Wake Island</i>	7 Nov 1943 17 Apr 1946		
66 <i>White Plains</i>	15 Nov 1943 27 Jun 1958	CVU 66	12 Jun 1955
67 <i>Solomons</i>	21 Nov 1943 5 Jun 1946		
68 <i>Kalinin Bay</i>	27 Nov 1943 5 Jun 1946		
69 <i>Kasaan Bay</i>	4 Dec 1943 1 Mar 1959	CVHE 69	12 Jun 1955
70 <i>Fanshaw Bay</i>	9 Dec 1943 1 Mar 1959	CVHE 70	12 Jun 1955
71 <i>Kitkun Bay</i>	15 Dec 1943 3 Jan 1947		
72 <i>Tulagi</i>	21 Dec 1943 8 May 1946		
73 <i>Gambier Bay</i>	28 Dec 1943 25 Oct 1944		
74 <i>Nebenta Bay</i>	3 Jan 1944 1 Aug 1959	CVU 74 AKV 24	12 Jun 1955 7 May 1959
75 <i>Hoggatt Bay</i>	11 Jan 1944 1 Aug 1959	CVHE 75 AKV 25	12 Jun 1955 7 May 1959
76 <i>Kadasban Bay</i>	18 Jan 1944 1 Aug 1959	CVU 76 AKV 26	12 Jun 1955 7 May 1959
77 <i>Marcus Island</i>	26 Jan 1944 1 Aug 1959	CVHE 77 AKV 27	12 Jun 1955 7 May 1959
78 <i>Savo Island</i>	3 Feb 1944 1 Sep 1959	CHVE 78 AKV 28	12 Jun 1955 7 May 1959
79 <i>Ommaney Bay</i>	11 Feb 1944 4 Jan 1945		
80 <i>Petrof Bay</i>	18 Feb 1944 27 Jun 1958	CVU 80	12 Jun 1955
81 <i>Rudyard Bay</i>	25 Feb 1944 1 Aug 1959	CVU 81 AKV 29	12 Jun 1955 7 May 1959
82 <i>Saginaw Bay</i>	2 Mar 1944 1 Mar 1959	CVHE 82	12 Jun 1955
83 <i>Sargent Bay</i>	9 Mar 1944 27 Jun 1958	CVU 83	12 Jun 1955
84 <i>Shamrock Bay</i>	15 Mar 1944 27 Jun 1958	CVU 84	12 Jun 1955
85 <i>Shipleigh Bay</i>	21 Mar 1944 1 Mar 1959	CVHE 85	12 Jun 1955
86 <i>Sitkoh</i>	28 Mar 1944 1 Apr 1960	CVU 86 AKV 30	12 Jun 1955 7 May 1959



**Carrier Listing for CVE Designations—Continued**

Hull No. Name	Date of commission and decommission, loss, stricken or transfer	Designations	Date of Change
87 <i>Steamer Bay</i>	4 Apr 1944 1 Mar 1959	CVHE 87	12 Jun 1955
88 <i>Cape Esperance</i>	9 Apr 1944 1 Mar 1959	CVU 88	12 Jun 1955
89 <i>Takanis Bay</i>	9 Apr 1944 1 Aug 1959	CVU 89 AKV 31	12 Jun 1955 7 May 1959
90 <i>Thetis Bay</i>	21 Apr 1944 1 Mar 1964	CVHA 1 LPH 6	1 Jul 1955 28 Apr 1959
91 <i>Makassar Strait</i>	27 Apr 1944 1 Sep 1958	CVU 91	12 Jun 1955
92 <i>Windbam Bay</i>	3 May 1944 1 Feb 1959	CVU 92	12 Jun 1955
93 <i>Makin Island</i>	9 May 1944 5 Jun 1946		
94 <i>Lunga Point</i>	14 May 1944 1 Apr 1960	CVU 94 AKV 32	12 Jun 1955 7 May 1959
95 <i>Bismarck Sea</i>	20 May 1944 21 Feb 1945		
96 <i>Salamaua</i>	26 May 1944 21 May 1946		
97 <i>Hollandia</i>	1 Jun 1944 1 Apr 1960	CVU 97 AKV 33	12 Jun 1955 7 May 1959
98 <i>Kwajalein</i>	7 Jun 1944 1 Apr 1960	CVU 98 AKV 34	12 Jun 1955 7 May 1959
99 <i>Admiralty Islands</i>	13 Jun 1944 8 May 1946		
100 <i>Bougainville</i>	18 Jun 1944 1 Apr 1960	CVU 100 AKV 35	12 Jun 1955 7 May 1959
101 <i>Matanikau</i>	24 Jun 1944 1 Apr 1960	CVU 101 AKV 36	12 Jun 1955 7 May 1959
102 <i>Attu</i>	30 Jun 1944 3 Jul 1946		
103 <i>Roi</i>	6 Jul 1944 21 May 1946		
104 <i>Munda</i>	8 Jul 1944 1 Sep 1958	CVU 104	12 Jun 1955
105 <i>Commencement Bay</i>	27 Nov 1944 1 Apr 1971	CVHE 105 AKV 37	12 Jun 1955 7 May 1959

**Carrier Listing for CVE Designations—Continued**

Hull No. Name	Date of commission and decommission, loss, stricken or transfer	Designations	Date of Change
106 <i>Block Island</i>	30 Dec 1944 1 Jul 1959	LPH 1 CVE 106 AKV 38	22 Dec 1957 17 Feb 1959 7 May 1959
107 <i>Gilbert Islands</i>	5 Feb 1945 1 Jun 1961	AKV 39	7 May 1959
108 <i>Kula Gulf</i>	12 May 1945 15 Sep 1970	AKV 8	7 May 1959
109 <i>Cape Gloucester</i>	3 Mar 1945 1 Apr 1971	CVHE 109 AKV 9	12 Jun 1955 7 May 1959
110 <i>Salerno Bay</i>	19 May 1945 1 Jun 1961	AKV 10	7 May 1959
111 <i>Vella Gulf</i>	9 Apr 1945 1 Jun 1960	CVHE 111 AKV 11	12 Jun 1955 7 May 1959
112 <i>Siboney</i>	14 May 1945 1 Jun 1970	AKV 12	7 May 1959
113 <i>Puget Sound</i>	18 Jun 1945 1 Jun 1960	CVHE 113 AKV 13	12 Jun 1955 7 May 1959
114 <i>Rendova</i>	22 Oct 1945 1 Apr 1971	AKV 14	7 May 1959
115 <i>Bairoko</i>	16 Jul 1945 1 Apr 1960	AKV 15	7 May 1959
116 <i>Badoeng Strait</i>	14 Nov 1945 1 Dec 1970	AKV 16	7 May 1959
117 <i>Saidor</i>	4 Sep 1945 1 Dec 1970	CVHE 117 AKV 17	12 Jun 1955 7 May 1959
118 <i>Sicily</i>	27 Feb 1946 1 Jul 1960	AKV 18	7 May 1959
119 <i>Point Cruz</i>	16 Oct 1945 15 Sep 1970	AKV 19	7 May 1959
120 <i>Mindoro</i>	4 Dec 1945 9 Dec 1959	AKV 20	7 May 1959
121 <i>Rabaul</i>	30 Aug 1946 1 Sep 1971	CVHE 121 AKV 21	12 Jun 1955 7 May 1959
122 <i>Palau</i>	15 Jan 1946 1 Apr 1960	AKV 22	7 May 1959
123 <i>Tinian</i>	30 Jul 1946 1 Jun 1970	CVHE 123 AKV 23	12 Jun 1955 7 May 1959

## APPENDIX 3

# Carrier Deployments by Year

**T**HE CARRIER DEPLOYMENT LISTS do not cover the deployments for escort carriers (CVEs), most of the small carriers (CVLs), or most of the antisubmarine carriers (CVS). Departure and return dates are normally from the carriers' home port or other state side port.

### Major Overseas Deployments for 1946

<i>Date of Departure</i>	<i>Date of Return</i>	<i>Air Wing</i>	<i>Carrier</i>	<i>Area of Operation</i>
08 Jan 1946	19 Mar 1946	CVBG-75	CVB 42	Carib/SoLant
20 Apr 1946	09 Aug 1946	CVG-19	CV 36	WestPac
03 Jul 1946	15 Apr 1947	CVG-81*	CV 37	WestPac
01 Aug 1946	29 Apr 1947	CVG-4†	CV 40	WestPac
08 Aug 1946	04 Oct 1946	CVBG-75	CVB 42	Med
16 Sep 1946	12 Dec 1946	CVG-18	CV 32	Carib/East Coast of South America
22 Oct 1946	21 Dec 1946	CVG-82‡	CV 15	Med

\*CVG-81 redesignated CVAG-13

†CVG-4 redesignated CVAG-1

‡CVG-82 redesignated CVAG-17

### Major Overseas Deployments for 1947

<i>Date of Departure</i>	<i>Date of Return</i>	<i>Air Wing</i>	<i>Carrier</i>	<i>Area of Operation</i>
02 Feb 1947	19 Mar 1947	CVAG-17	CV 15	EasternLant/Carib
31 Mar 1947	16 Jun 1947	CVG-5	CV 38	WestPac
31 Mar 1947	08 Oct 1947	CVAG-15	CV 36	WestPac
03 Apr 1947	09 Jun 1947	CVAG-7	CV 32	Med
20 May 1947	11 Aug 1947	CVAG-17	CV 15	NorLant/Carib
07 Jun 1947	11 Aug 1947	CVAG-3	CV 33	NorLant/Carib
30 Jul 1947	19 Nov 1947	CVAG-7	CV 32	Med
09 Oct 1947	11 Jun 1948	CVAG-11	CV 45	World Cruise
29 Oct 1947	11 Mar 1948	CVBG-1	CVB 41	Med

### Major Overseas Deployments for 1948

<i>Date of Departure</i>	<i>Date of Return</i>	<i>Air Wing</i>	<i>Carrier</i>	<i>Area of Operation</i>
07 Feb 1948	24 Feb 1948	CVLG-1	CVL 48	Carib
09 Feb 1948	26 Jun 1948	CVAG-9	CV 47	Carib/Med
01 Jun 1948	02 Oct 1948	CVG-3	CV 33	Med
07 Jun 1948	06 Aug 1948	CVG-17	CVB 43	Med/Carib
13 Sep 1948	23 Jan 1949	CVG-4	CVB 42	Med
01 Oct 1948	23 Dec 1948	CVG-13	CV 37	WestPac
01 Oct 1948	21 Feb 1949	CVG-1	CV 40	World Cruise

**Major Overseas Deployments for 1949**

<i>Date of Departure</i>	<i>Date of Return</i>	<i>Air Wing</i>	<i>Carrier</i>	<i>Area of Operation</i>
04 Jan 1949	05 Mar 1949	CVG-6	CVB 41	Med
04 Jan 1949	22 May 1949	CVG-7	CV 47	Med
03 May 1949	26 Sep 1949	CVG-2	CVB 43	Med
06 Sep 1949	26 Jan 1950	CVG-7	CV 32	Med
27 Oct 1949	23 Nov 1949	CVG-6	CVB 42	NorLant

**Major Overseas Deployments for 1950**

<i>Date of Departure</i>	<i>Date of Return</i>	<i>Air Wing</i>	<i>Carrier</i>	<i>Area of Operation</i>
06 Jan 1950	23 May 1950	CVG-4	CVB 41	Med
11 Jan 1950	13 Jun 1950	CVG-19	CV 21	WestPac
01 May 1950	01 Dec 1950	CVG-5	CV 45	WestPac/Korea
02 May 1950	24 Aug 1950	CVG-3	CV 32	Med
05 Jul 1950	09 Jun 1951	CVG-11*	CV 47	WestPac/Korea
10 Jul 1950	10 Nov 1950	CVG-7	CVB 41	Med
24 Aug 1950	11 Nov 1950	CVG-2	CV 21	WestPac/Korea
09 Sep 1950	01 Feb 1951	CVG-17	CVB 43	Med
19 Sep 1950	03 Feb 1951	CVG-3	CV 32	WestPac/Korea
09 Nov 1950	09 Jun 1951	CVG-19	CV 37	WestPac/Korea
06 Dec 1950	07 Apr 1951	CVG-2†	CV 45	WestPac/Korea

\* CVG-11 deployed to Korea embarked in Philippine Sea (CV 47) and on 29 March 1951 transferred to Valley Forge (CV 45) and CVG-2 transferred from Valley Forge to Philippine Sea. CVG-11 returned to the States embarked in Valley Forge.

† CVG-2 deployed to Korea embarked in Valley Forge (CV 45). On 29 March 1951 the CVG-2 transferred to Philippine Sea (CV 47) and CVG-11 transferred to Valley Forge (CV 45).

**Major Overseas Deployments for 1951**

<i>Date of Departure</i>	<i>Date of Return</i>	<i>Air Wing</i>	<i>Carrier</i>	<i>Area of Operation</i>
10 Jan 1951	18 May 1951	CVG-6	CVB 42	Med
02 Mar 1951	24 Oct 1951	CVG-101	CV 21	WestPac/Korea
06 Mar 1951	08 Jun 1951	AirDet	CVL 48	Med
20 Mar 1951	06 Oct 1951	CVG-1	CVB 43	Med
10 May 1951	17 Dec 1951	CVG-102	CV 31	Korea
15 May 1951	04 Oct 1951	CVG-4	CV 34	Med
16 May 1951	29 Aug 1951	CVG-19	CV 37	WestPac/Korea
26 Jun 1951	25 Mar 1952	CVG-5	CV 9	WestPac/Korea
03 Sep 1951	21 Dec 1951	CVG-3	CV 32	Med
03 Sep 1951	04 Feb 1952	CVG-17	CVB 42	Med
08 Sep 1951	02 May 1952	CVG-15	CV 36	Korea
15 Oct 1951	03 Jul 1952	ATG-1	CV 45	WestPac/Korea
28 Nov 1951	11 Jun 1952	CVG-8	CV 40	Med
31 Dec 1951	08 Aug 1952	CVG-11	CV 47	WestPac/Korea

**Major Overseas Deployments for 1952**

<i>Date of Departure</i>	<i>Date of Return</i>	<i>Air Wing</i>	<i>Carrier</i>	<i>Area of Operation</i>
09 Jan 1952	05 May 1952	CVG-6	CVB 41	Med
08 Feb 1952	26 Sep 1952	CVG-2	CV 21	WestPac/Korea
21 Mar 1952	03 Nov 1952	CVG-19	CV 37	WestPac/Korea
19 Apr 1952	12 Oct 1952	CVG-4	CVB 43	Med

**Major Overseas Deployments for 1952—Continued**

<i>Date of Departure</i>	<i>Date of Return</i>	<i>Air Wing</i>	<i>Carrier</i>	<i>Area of Operation</i>
20 May 1952	08 Jan 1953	CVG-7	CV 31	WestPac/Korea
24 May 1952	11 Oct 1952	CVG-1	CV 18	Med/NorLant
16 Jun 1952	06 Feb 1953	ATG-2	CVA 9	WestPac/Korea
11 Aug 1952	17 Mar 1953	CVG-101	CVA 33	WestPac/Korea
26 Aug 1952	08 Oct 1952	CVG-6	CVB 41	NorLant
26 Aug 1952	19 Dec 1952	CVG-17	CVB 42	NorLant/Med
28 Aug 1952	04 Feb 1953	CVG-3	CVA 32	Med
15 Sep 1952	18 May 1953	CVG-102	CVA 34	WestPac/Korea
20 Nov 1952	25 Jun 1953	CVG-5	CVA 45	WestPac/Korea
01 Dec 1952	19 May 1953	CVG-6	CVA 41	Med
15 Dec 1952	14 Aug 1953	CVG-9	CVA 47	WestPac/Korea

**Major Overseas Deployments for 1953**

<i>Date of Departure</i>	<i>Date of Return</i>	<i>Air Wing</i>	<i>Carrier</i>	<i>Area of Operation</i>
07 Jan 1953	03 Jul 1953	CVG-10	CVA 40	Med
24 Jan 1953	21 Sep 1953	CVG-15	CVA 37	Korea/WestPac
30 Mar 1953	28 Nov 1953	ATG-1	CVA 21	WestPac/Korea
26 Apr 1953	04 Dec 1953	CVG-4	CVA 39	Med/IO/WestPac/Korea
26 Apr 1953	21 Oct 1953	CVG-8	CVA 43	Med
11 Jun 1953	03 Dec 1953	CVG-1	CVA 42	Med
11 Jun 1953	21 Jul 1953	*	CV 36	NorLant
01 Jul 1953	18 Jan 1954	CVG-11	CVA 33	Korea/WestPac
03 Aug 1953	03 Mar 1954	CVG-2	CVA 10	WestPac
14 Sep 1953	22 Apr 1954	CVG-19	CVA 34	WestPac
16 Sep 1953	01 May 1954	CVG-17	CVA 18	World Cruise
16 Sep 1953	21 Feb 1954	CVG-7	CVA 20	NorLant/Med
12 Nov 1953	19 Aug 1954	CVG-3	CVA 40	World Cruise
01 Dec 1953	12 Jul 1954	ATG-2	CVA 9	WestPac

\* The carrier deployed with VF-84, VC-4 and VS-27 but did not have an assigned air group.

**Major Overseas Deployments for 1954**

<i>Date of Departure</i>	<i>Date of Return</i>	<i>Air Wing</i>	<i>Carrier</i>	<i>Area of Operation</i>
04 Jan 1954	04 Aug 1954	CVG-6	CVA 41	Med
03 Feb 1954	06 Aug 1954	CVG-14	CVA 15	Med
03 Mar 1954	11 Oct 1954	CVG-12	CVA 21	WestPac
12 Mar 1954	19 Nov 1954	CVG-5	CVA 47	WestPac
11 May 1954	12 Dec 1954	CVG-9	CVA 12	World Cruise
07 Jul 1954	20 Dec 1954	CVG-10	CVA 43	Med
01 Jul 1954	28 Feb 1955	CVG-15	CVA 10	WestPac
01 Sep 1954	11 Apr 1955	ATG-1	CVA 18	WestPac
28 Sep 1954	22 Apr 1955	CVG-8	CVA 39	Med
07 Oct 1954	12 May 1955	CVG-11	CVA 33	WestPac
03 Nov 1954	21 Jun 1955	CVG-2	CVA 9	WestPac
30 Nov 1954	18 Jun 1955	ATG-181	CVA 15	Med
27 Dec 1954	14 Jul 1955	CVG-1	CVA 41	World Cruise

**Major Overseas Deployments for 1955**

<i>Date of Departure</i>	<i>Date of Return</i>	<i>Air Wing</i>	<i>Carrier</i>	<i>Area of Operation</i>
02 Mar 1955	21 Sep 1955	CVG-19	CVA 34	WestPac
01 Apr 1955	23 Nov 1955	ATG-2	CVA 47	WestPac
05 Apr 1955	29 Sep 1955	CVG-17	CVA 43	Med
04 May 1955	10 Dec 1955	CVG-7	CVA 12	WestPac
28 May 1955	22 Nov 1955	CVG-4	CVA 11	Med
03 Jun 1955	03 Feb 1956	CVG-14	CVA 21	WestPac
10 Aug 1955	15 Mar 1956	CVG-12	CVA 19	WestPac
09 Oct 1955	30 Apr 1956	CVG-6	CVA 39	Med
29 Oct 1955	17 May 1956	CVG-5	CVA 33	WestPac
31 Oct 1955	16 Apr 1956	ATG-201	CVA 20	WestPac
04 Nov 1955	02 Aug 1956	CVG-3	CVA 14	Med

**Major Overseas Deployments for 1956**

<i>Date of Departure</i>	<i>Date of Return</i>	<i>Air Wing</i>	<i>Carrier</i>	<i>Area of Operation</i>
05 Jan 1956	23 Jun 1956	ATG-3	CVA 38	WestPac
11 Feb 1956	13 Jun 1956	CVG-9	CVA 34	WestPac
12 Mar 1956	05 Sep 1956	CVG-8	CVA 11	Med
19 Mar 1956	13 Sep 1956	ATG-4	CVA 10	WestPac
23 Apr 1956	15 Oct 1956	CVG-15	CVA 18	WestPac
28 May 1956	20 Dec 1956	ATG-1	CVA 16	WestPac
14 Jul 1956	19 Feb 1957	ATG-202	CVA 15	Med
16 Jul 1956	26 Jan 1957	CVG-11	CVA 9	WestPac
13 Aug 1956	11 Feb 1957	CVG-10	CVA 43	Med
16 Aug 1956	28 Feb 1957	CVG-21	CVA 31	WestPac
15 Oct 1956	22 May 1957	ATG-181	CVA 20	WestPac
07 Nov 1956	12 Dec 1956	CVG-1	CVA 59	Azores
13 Nov 1956	20 May 1957	CVG-2	CVA 38	WestPac

**Major Overseas Deployments for 1957**

<i>Date of Departure</i>	<i>Date of Return</i>	<i>Air Wing</i>	<i>Carrier</i>	<i>Area of Operation</i>
15 Jan 1957	22 Jul 1957	CVG-1	CVA 59	Med
21 Jan 1957	25 Jul 1957	CVG-14	CVA 12	WestPac
21 Jan 1957	27 Jul 1957	ATG-182	CVA 39	Med
09 Mar 1957	25 Aug 1957	CVG-19	CVA 10	WestPac
06 Apr 1957	18 Sep 1957	ATG-2	CVA 19	WestPac
19 Apr 1957	17 Oct 1957	CVG-12	CVA 16	WestPac
01 Jul 1957	24 Feb 1958	CVG-4	CVA 15	Med
12 Jul 1957	09 Dec 1957	CVG-5	CVA 31	WestPac
12 Jul 1957	05 Mar 1958	CVG-17	CVA 42	Med
09 Aug 1957	02 Apr 1958	ATG-3	CVA 33	WestPac
16 Aug 1957	21 Oct 1957	CVG-1	CVA 59	NorLant
30 Aug 1957	22 Oct 1957	*	CVS 18	NorLant
03 Sep 1957	22 Oct 1957	CVG-6	CVA 11	NorLant
03 Sep 1957	22 Oct 1957	CVG-7	CVA 60	NorLant
16 Sep 1957	25 Apr 1958	CVG-9	CVA 14	WestPac

\* Unable to locate records indicating a carrier air group (CVG) was assigned to the carrier during the deployment. CVSGs (Antisubmarine Carrier Air Groups) were not established until 1960.

**Major Overseas Deployments for 1958**

<i>Date of Departure</i>	<i>Date of Return</i>	<i>Air Wing</i>	<i>Carrier</i>	<i>Area of Operation</i>
06 Jan 1958	30 Jun 1958	ATG-4	CVA 12	WestPac
01 Feb 1958	01 Oct 1958	CVG-3	CVA 60	Med
02 Feb 1958	17 Nov 1958	ATG-201	CVA 9	Med/IO/WestPac
15 Feb 1958	02 Oct 1958	CVG-15	CVA 19	WestPac
08 Mar 1958	21 Nov 1958	CVG-11	CVA 38	WestPac
09 Jun 1958	08 Aug 1958	ATG-181	CVA 11	NorLant
20 Jun 1958	20 Aug 1958	CVG-14	CVA 61	SoLant/SoPac
14 Jul 1958	19 Dec 1958	CVG-21	CVA 16	WestPac
16 Aug 1958	12 Mar 1959	CVG-2	CVA 41	WestPac
21 Aug 1958	12 Jan 1959	ATG-4	CVA 20	WestPac
02 Sep 1958	12 Mar 1959	CVG-10	CVA 59	Med
02 Sep 1958	12 Mar 1959	CVG-7	CVA 15	Med
04 Oct 1958	16 Feb 1959	ATG-1	CVA 14	WestPac
01 Nov 1958	18 Jun 1959	CVG-19	CVA 31	WestPac

**Major Overseas Deployments for 1959**

<i>Date of Departure</i>	<i>Date of Return</i>	<i>Air Wing</i>	<i>Carrier</i>	<i>Area of Operation</i>
03 Jan 1959	27 Jul 1959	CVG-14	CVA 61	WestPac
13 Feb 1959	01 Sep 1959	CVG-1	CVA 42	Med
13 Feb 1959	30 Aug 1959	CVG-6	CVA 11	Med
09 Mar 1959	03 Oct 1959	CVG-11	CVA 38	WestPac
26 Apr 1959	02 Dec 1959	CVG-21	CVA 16	WestPac
01 Aug 1959	18 Jan 1960	CVG-15	CVA 19	WestPac
07 Aug 1959	26 Feb 1960	CVG-10	CVA 9	Med
15 Aug 1959	25 Mar 1960	CVG-2	CVA 41	WestPac
15 Aug 1959	26 Feb 1960	CVG-3	CVA 60	Med
21 Nov 1959	14 May 1960	CVG-19	CVA 31	WestPac

**Major Overseas Deployments for 1960**

<i>Date of Departure</i>	<i>Date of Return</i>	<i>Air Wing</i>	<i>Carrier</i>	<i>Area of Operation</i>
28 Jan 1960	24 Aug 1960	CVG-1	CVA 42	Med
28 Jan 1960	31 Aug 1960	CVG-8	CVA 59	Med
06 Feb 1960	30 Aug 1960	CVG-9	CVA 61	WestPac
05 Mar 1960	11 Oct 1960	CVG-5	CVA 14	WestPac
14 May 1960	15 Dec 1960	CVG-14	CVA 34	WestPac
16 Jul 1960	18 Mar 1961	CVG-11	CVA 19	WestPac
04 Aug 1960	17 Feb 1961	CVG-6	CVA 11	Med
04 Aug 1960	03 Mar 1961	CVG-7	CVA 62	Med
22 Aug 1960	26 Feb 1961	CVG-3	CVA 60	Med/NorLant
06 Sep 1960	20 Oct 1960	CVG-10	CVA 38	NorLant
19 Sep 1960	27 May 1961	CVG-15	CVA 43	WestPac
29 Oct 1960	06 Jun 1961	CVG-21	CVA 16	WestPac
14 Nov 1960	27 Nov 1960	CVG-10	CVA 38	Carib

**Major Overseas Deployments for 1961**

<i>Date of Departure</i>	<i>Date of Return</i>	<i>Air Wing</i>	<i>Carrier</i>	<i>Area of Operation</i>
02 Feb 1961	15 May 1961	CVG-10	CVA 38	Med
09 Feb 1961	25 Aug 1961	CVG-8	CVA 59	Med
15 Feb 1961	28 Aug 1961	CVG-1	CVA 42	Med
16 Feb 1961	28 Sep 1961	CVG-2	CVA 41	WestPac
26 Apr 1961	13 Dec 1961	CVG-19	CVA 31	WestPac
10 May 1961	15 Jan 1962	CVG-5	CVA 14	WestPac
05 Jul 1961	22 Aug 1961	CVG-3	CVA 60	Carib
03 Aug 1961	01 Mar 1962	CVG-6	CVA 11	Med
04 Aug 1961	19 Dec 1961	CVG-7	CVA 62	Med
11 Aug 1961	08 Mar 1962	CVG-9	CVA 61	WestPac
11 Aug 1961	01 Nov 1961	CVG-11	CVA 63	*
09 Nov 1961	12 May 1962	CVG-14	CVA 16	WestPac
19 Nov 1961	30 Nov 1961	CVG-1	CVA 42	Carib
28 Nov 1961	12 May 1962	CVG-3	CVA 60	Med
12 Dec 1961	17 Jul 1962	CVG-15	CVA 43	WestPac

\* The *Kitty Hawk* (CVA 63) changed home ports from the Atlantic to the Pacific. During the transit to the Pacific, via Cape Horn, the carrier and its embarked squadrons participated in operations in the Caribbean, South Atlantic and eastern Pacific.

**Major Overseas Deployments for 1962**

<i>Date of Departure</i>	<i>Date of Return</i>	<i>Air Wing</i>	<i>Carrier</i>	<i>Area of Operation</i>
02 Feb 1962	24 Aug 1962	CVG-21	CVA 19	WestPac
07 Feb 1962	28 Aug 1962	CVG-10	CVA 38	Med
06 Apr 1962	20 Oct 1962	CVG-2	CVA 41	WestPac
19 Apr 1962	27 Aug 1962	CVG-7	CVA 62	Med
07 Jun 1962	17 Dec 1962	CVG-16	CVA 34	WestPac
12 Jul 1962	11 Feb 1963	CVG-19	CVA 31	WestPac
21 Jul 1962	11 Sep 1962	CVG-5*	CVA 16	SoPac/SoLant
25 Jul 1962	17 Sep 1962	CVG-5	CVA 64	SoLant/West Coast
03 Aug 1962	11 Oct 1962	CVG-6	CVAN 65	Med
03 Aug 1962	02 Mar 1963	CVG-8	CVA 59	Med
13 Sep 1962	02 Apr 1963	CVG-11	CVA 63	WestPac
14 Sep 1962	22 Apr 1963	CVG-1	CVA 42	Med
19 Oct 1962	06 Dec 1962	CVG-6	CVAN 65	Carib
09 Nov 1962	14 Jun 1963	CVG-9	CVA 61	WestPac
03 Dec 1962	21 Dec 1962	CVG-3	CVA 60	Carib

\* Only two squadrons from CVG-5 were aboard *Lexington* (CVA 16) during her home port change and transit from the Pacific Fleet to the Atlantic Fleet.

**Major Overseas Deployments for 1963**

<i>Date of Departure</i>	<i>Date of Return</i>	<i>Air Wing</i>	<i>Carrier</i>	<i>Area of Operation</i>
03 Jan 1963	15 Jul 1963	CVG-5	CVA 14	WestPac/NorPac
06 Feb 1963	04 Sep 1963	CVG-6	CVAN 65	Med
21 Feb 1963	10 Sep 1963	CVG-14	CVA 64	WestPac
29 Mar 1963	25 Oct 1963	CVG-3	CVA 60	Med
03 Apr 1963	25 Nov 1963	CVG-15	CVA 43	WestPac

**Major Overseas Deployments for 1963—Continued**

<i>Date of Departure</i>	<i>Date of Return</i>	<i>Air Wing</i>	<i>Carrier</i>	<i>Area of Operation</i>
07 Jun 1963	16 Dec 1963	CVG-21	CVA 19	WestPac
01 Aug 1963	10 Mar 1964	CVW-16	CVA 34	WestPac
06 Aug 1963	04 Mar 1964	CVG-7	CVA 62	Med
01 Oct 1963	23 May 1964	CVG-10	CVA 38	Med
17 Oct 1963	20 Jul 1964	CVW-11	CVA 63	WestPac
08 Nov 1963	26 May 1964	CVW-2	CVA 41	WestPac

**Major Overseas Deployments for 1964**

<i>Date of Departure</i>	<i>Date of Return</i>	<i>Air Wing</i>	<i>Carrier</i>	<i>Area of Operation</i>
28 Jan 1964	21 Nov 1964	CVW-19	CVA 31	WestPac/IO/Vietnam
08 Feb 1964	03 Oct 1964	CVW-6	CVAN 65	Med/World Cruise
14 Apr 1964	15 Dec 1964	CVW-5	CVA 14	WestPac/Vietnam
28 Apr 1964	22 Dec 1964	CVW-1	CVA 42	Med
05 May 1964	01 Feb 1965	CVW-14	CVA 64	WestPac/Vietnam
10 Jul 1964	13 Mar 1965	CVW-8	CVA 59	Med
05 Aug 1964	06 May 1965	CVW-9	CVA 61	WestPac/Vietnam
08 Sep 1964	05 Nov 1964	CVW-7	CVA 62	NorLant/Med
21 Oct 1964	29 May 1965	CVW-21	CVA 19	WestPac/Vietnam
28 Nov 1964	12 Jul 1965	CVW-3	CVA 60	Med
07 Dec 1964	01 Nov 1965	CVW-15	CVA 43	WestPac/Vietnam

**Major Overseas Deployments for 1965**

<i>Date of Departure</i>	<i>Date of Return</i>	<i>Air Wing</i>	<i>Carrier</i>	<i>Area of Operation</i>
10 Feb 1965	20 Sep 1965	CVW-10	CVA 38	Med
06 Mar 1965	23 Nov 1965	CVW-2	CVA 41	WestPac/Vietnam
05 Apr 1965	16 Dec 1965	CVW-16	CVA 34	WestPac/Vietnam
21 Apr 1965	13 Jan 1966	CVW-19	CVA 31	WestPac/Vietnam
10 May 1965	13 Dec 1965	CVW-7	CVA 62	WestPac/Vietnam
28 Jun 1965	17 Dec 1965	CVW-1	CVA 42	Med
24 Aug 1965	07 Apr 1966	CVW-8	CVA 59	Med
19 Oct 1965	13 Jun 1966	CVW-11	CVA 63	WestPac/Vietnam
26 Oct 1965	21 Jun 1966	CVW-9	CVAN 65	SoLant/IO/WestPac/Vietnam
28 Sep 1965	13 May 1966	CVW-5	CVA 14	WestPac/Vietnam
10 Nov 1965	01 Aug 1966	CVW-21	CVA 19	WestPac/Vietnam
30 Nov 1965	10 Jul 1966	CVW-6	CVA 66	Med
10 Dec 1965	25 Aug 1966	CVW-14	CVA 61	WestPac/Vietnam

**Major Overseas Deployments for 1966**

<i>Date of Departure</i>	<i>Date of Return</i>	<i>Air Wing</i>	<i>Carrier</i>	<i>Area of Operation</i>
11 Mar 1966	26 Oct 1966	CVW-3	CVA 60	Med
04 Apr 1966	21 Nov 1966	CVW-10	CVS 11	Med/IO/WestPac/Vietnam
12 May 1966	03 Dec 1966	CVW-15	CVA 64	WestPac/Vietnam
26 May 1966	16 Nov 1966	CVW-16	CVA 34	WestPac/Vietnam



**Major Overseas Deployments for 1966—Continued**

<i>Date of Departure</i>	<i>Date of Return</i>	<i>Air Wing</i>	<i>Carrier</i>	<i>Area of Operation</i>
13 Jun 1966	01 Feb 1967	CVW-7	CVA 62	Med
21 Jun 1966	21 Feb 1967	CVW-1	CVA 42	SoLant/IO/WestPac/Vietnam
29 Jul 1966	23 Feb 1967	CVW-2	CVA 43	WestPac/Vietnam
29 Sep 1966	20 May 1967	CVW-8	CVA 38	Med
15 Oct 1966	29 May 1967	CVW-19	CVA 14	WestPac/Vietnam
05 Nov 1966	19 Jun 1967	CVW-11	CVA 63	WestPac/Vietnam
19 Nov 1966	06 Jul 1967	CVW-9	CVAN 65	WestPac/Vietnam

**Major Overseas Deployments for 1967**

<i>Date of Departure</i>	<i>Date of Return</i>	<i>Air Wing</i>	<i>Carrier</i>	<i>Area of Operation</i>
05 Jan 1967	22 Jul 1967	CVW-5	CVA 19	WestPac/Vietnam
10 Jan 1967	20 Sep 1967	CVW-6	CVA 66	Med
26 Jan 1967	25 Aug 1967	CVW-21	CVA 31	WestPac/Vietnam
29 Apr 1967	04 Dec 1967	CVW-14	CVA 64	WestPac/Vietnam
02 May 1967	06 Dec 1967	CVW-3	CVA 60	Med
11 May 1967	30 Dec 1967	CVW-10	CVS 11	Med/IO/WestPac/Vietnam
06 Jun 1967	15 Sep 1967	CVW-17	CVA 59	WestPac/Vietnam
16 Jun 1967	31 Jan 1968	CVW-16	CVA 34	WestPac/Vietnam
26 Jul 1967	06 Apr 1968	CVW-15	CVA 43	WestPac/Vietnam
24 Aug 1967	19 May 1968	CVW-1	CVA 42	Med
04 Nov 1967	25 May 1968	CVW-2	CVA 61	WestPac/Vietnam
15 Nov 1967	04 Aug 1968	CVW-8	CVA 38	Med
18 Nov 1967	28 Jun 1968	CVW-11	CVA 63	WestPac/Vietnam
28 Dec 1967	17 Aug 1968	CVW-19	CVA 14	WestPac/Vietnam

**Major Overseas Deployments for 1968**

<i>Date of Departure</i>	<i>Date of Return</i>	<i>Air Wing</i>	<i>Carrier</i>	<i>Area of Operation</i>
03 Jan 1968	18 Jul 1968	CVW-9	CVAN 65	WestPac/Vietnam
27 Jan 1968	10 Oct 1968	CVW-5	CVA 31	WestPac/Vietnam
10 Apr 1968	16 Dec 1968	CVW-6	CVA 66	World Cruise/Vietnam
30 Apr 1968	27 Jan 1969	CVW-7	CVA 62	Med
29 May 1968	31 Jan 1969	CVW-14	CVA 64	WestPac/Vietnam
04 Jun 1968	08 Feb 1969	CVW-10	CVS 11	SoLant/IO/Pacific/Vietnam
18 Jul 1968	03 Mar 1969	CVW-21	CVA 19	WestPac/Vietnam
22 Jul 1968	29 Apr 1969	CVW-17	CVA 59	Med
07 Sep 1968	18 Apr 1969	CVW-15	CVA 43	WestPac/Vietnam
26 Oct 1968	17 May 1969	CVW-2	CVA 61	WestPac/Vietnam
30 Dec 1968	04 Sep 1969	CVW-11	CVA 63	WestPac/Vietnam

**Major Overseas Deployments for 1969**

<i>Date of Departure</i>	<i>Date of Return</i>	<i>Air Wing</i>	<i>Carrier</i>	<i>Area of Operation</i>
06 Jan 1969	02 Jul 1969	CVW-9	CVAN 65	WestPac/Vietnam
07 Jan 1969	29 Jul 1969	CVW-8	CVA 38	Med
01 Feb 1969	18 Sep 1969	CVW-16	CVA 14	WestPac/Vietnam
18 Mar 1969	29 Oct 1969	CVW-5	CVA 31	WestPac/Vietnam
05 Apr 1969	21 Dec 1969	CVW-1	CVA 67	Med

**Major Overseas Deployments for 1969—Continued**

<i>Date of Departure</i>	<i>Date of Return</i>	<i>Air Wing</i>	<i>Carrier</i>	<i>Area of Operation</i>
14 Apr 1969	17 Nov 1969	CVW-19	CVA 34	WestPac/Vietnam
09 Jul 1969	22 Jan 1970	CVW-3	CVA 60	Med
02 Aug 1969	15 Apr 1970	CVW-21	CVA 19	WestPac/Vietnam
11 Aug 1969	08 May 1970	CVW-14	CVA 64	WestPac/Vietnam
03 Sep 1969	09 Oct 1969	CVW-7	CVA 62	NorLant
23 Sep 1969	01 Jul 1970	CVW-15	CVA 43	WestPac/Vietnam
14 Oct 1969	01 Jun 1970	CVW-2	CVA 61	WestPac/Vietnam
02 Dec 1969	08 Jul 1970	CVW-17	CVA 59	Med

**Major Overseas Deployments for 1970**

<i>Date of Departure</i>	<i>Date of Return</i>	<i>Air Wing</i>	<i>Carrier</i>	<i>Area of Operation</i>
02 Jan 1970	27 Jul 1970	CVW-6	CVA 42	Med
05 Mar 1970	17 Dec 1970	CVW-8	CVS 38	SoLant/IO/WestPac/Vietnam
02 Apr 1970	12 Nov 1970	CVW-5	CVA 31	WestPac/Vietnam
10 Apr 1970	21 Dec 1970	CVW-9	CVA 66	WestPac/Vietnam
14 May 1970	10 Dec 1970	CVW-19	CVA 34	WestPac/Vietnam
17 Jun 1970	09 Nov 1970	CVW-3	CVA 60	Med
23 Jun 1970	31 Jan 1971	CVW-7	CVA 62	Med
14 Sep 1970	01 Mar 1971	CVW-1	CVA 67	Carib/Med/NorLant
22 Oct 1970	03 Jun 1971	CVW-21	CVA 19	WestPac/Vietnam
27 Oct 1970	17 Jun 1971	CVW-2	CVA 61	WestPac/Vietnam
06 Nov 1970	17 Jul 1971	CVW-11	CVA 63	WestPac/Vietnam

**Major Overseas Deployments for 1971**

<i>Date of Departure</i>	<i>Date of Return</i>	<i>Air Wing</i>	<i>Carrier</i>	<i>Area of Operation</i>
05 Jan 1971	02 Jul 1971	CVW-17	CVA 59	Med
29 Jan 1971	23 Jul 1971	CVW-6	CVA 42	Med
16 Apr 1971	06 Nov 1971	CVW-5	CVA 41	WestPac/Vietnam
14 May 1971	18 Dec 1971	CVW-19	CVA 34	WestPac/Vietnam
07 Jun 1971	28 Oct 1971	CVW-3	CVA 60	NorLant/Med
11 Jun 1971	12 Feb 1972	CVW-14	CVAN 65	WestPac/Vietnam/IO
06 Jul 1971	16 Dec 1971	CVW-8	CVA 66	Med
16 Sep 1971	16 Mar 1972	CVW-7	CVA 62	NorLant/Med
01 Oct 1971	30 Jun 1972	CVW-9	CVA 64	WestPac/Vietnam
12 Nov 1971	17 Jul 1972	CVW-15	CVA 43	WestPac/Vietnam
01 Dec 1971	06 Oct 1972	CVW-1	CVA 67	Med/NorLant

**Major Overseas Deployments for 1972**

<i>Date of Departure</i>	<i>Date of Return</i>	<i>Air Wing</i>	<i>Carrier</i>	<i>Area of Operation</i>
07 Jan 1972	03 Oct 1972	CVW-21	CVA 19	WestPac/Vietnam
15 Feb 1972	08 Dec 1972	CVW-6	CVA 42	Med
17 Feb 1972	28 Nov 1972	CVW-11	CVA 63	WestPac/Vietnam
10 Apr 1972	03 Mar 1973	CVW-5	CVA 41	WestPac/Vietnam
11 Apr 1972	13 Feb 1973	CVW-3	CV 60	SoLant/IO/WestPac/Vietnam
05 Jun 1972	24 Mar 1973	CVW-8	CVA 66	WestPac/Vietnam
05 Jun 1972	30 Mar 1973	CVW-19	CVA 34	WestPac/Vietnam

**Major Overseas Deployments for 1972—Continued**

<i>Date of Departure</i>	<i>Date of Return</i>	<i>Air Wing</i>	<i>Carrier</i>	<i>Area of Operation</i>
12 Sep 1972	12 Jun 1973	CVW-14	CVAN 65	WestPac/Vietnam
22 Sep 1972	06 Jul 1973	CVW-17	CVA 59	Med
16 Nov 1972	23 Jun 1973	CVW-2	CVA 61	WestPac/Vietnam

**Major Overseas Deployments for 1973**

<i>Date of Departure</i>	<i>Date of Return</i>	<i>Air Wing</i>	<i>Carrier</i>	<i>Area of Operation</i>
05 Jan 1973	11 Oct 1973	CVW-9	CVA 64	WestPac/Vietnam
09 Mar 1973	08 Nov 1973	CVW-15	CVA 43	WestPac
16 Apr 1973	01 Dec 1973	CVW-1	CVA 67	Med/NorLant/Med
08 May 1973	08 Jan 1974	CVW-21	CVA 19	WestPac/IO
21 Jun 1973	19 Jan 1974	CVW-7	CV 62	Med
11 Sep 1973	05 Oct 1973	CVW-5	CVA 41*	WestPac
14 Sep 1973	17 Mar 1974	CVW-6	CVA 42	Med
18 Oct 1973	05 Jun 1974	CVW-19	CVA 34	WestPac/IO
23 Nov 1973	09 Jul 1974	CVW-11	CV 63	WestPac/IO
26 Nov 1973	22 Dec 1973	CVW-5	CVA 41*	WestPac

\* *Midway* (CVA 41) with CVW-5 and its assigned squadrons were forward deployed and home ported overseas at Naval Station Yokosuka, Japan. Only operations outside the home waters of Japan are listed as deployments.

**Major Overseas Deployments for 1974**

<i>Date of Departure</i>	<i>Date of Return</i>	<i>Air Wing</i>	<i>Carrier</i>	<i>Area of Operation</i>
03 Jan 1974	03 Aug 1974	CVW-8	CVA 66	Med
29 Jan 1974	06 Mar 1974	CVW-5	CVA 41*	WestPac
11 Mar 1974	11 Sep 1974	CVW-17	CVA 59	Med
07 May 1974	18 Oct 1974	CVW-2	CVA 61	WestPac
21 Jun 1974	22 Dec 1974	CVW-9	CVA 64	WestPac/IO
19 Jul 1974	21 Jan 1975	CVW-7	CV 62	Med
06 Sep 1974	12 Oct 1974	CVW-8	CVA 66	NorLant
17 Sep 1974	20 May 1975	CVW-14	CVAN 65	WestPac/IO
27 Sep 1974	19 Mar 1975	CVW-3	CV 60	Med
18 Oct 1974	20 Dec 1974	CVW-5	CVA 41*	WestPac
05 Dec 1974	02 Jul 1975	CVW-15	CVA 43	WestPac

\* *Midway* (CVA 41) with CVW-5 and its assigned squadrons were forward deployed and home ported overseas at Naval Station Yokosuka, Japan. Only operations outside the home waters of Japan are listed as deployments.

**Major Overseas Deployments for 1975**

<i>Date of Departure</i>	<i>Date of Return</i>	<i>Air Wing</i>	<i>Carrier</i>	<i>Area of Operation</i>
03 Jan 1975	16 Jul 1975	CVW-6	CV 42	Med
13 Jan 1975	18 Feb 1975	CVW-5	CVA 41*	WestPac
05 Mar 1975	22 Sep 1975	CVW-17	CV 59	Med
18 Mar 1975	20 Oct 1975	CVW-21	CV 19	WestPac
31 Mar 1975	29 May 1975	CVW-5	CVA 41*	WestPac
21 May 1975	15 Dec 1975	CVW-11	CV 63	WestPac
28 Jun 1975	27 Jan 1976	CVW-1	CV 67	Med
16 Jul 1975	24 Sep 1975	CVW-8	CVN 68	Carib/NorLant

**Major Overseas Deployments for 1975—Continued**

<i>Date of Departure</i>	<i>Date of Return</i>	<i>Air Wing</i>	<i>Carrier</i>	<i>Area of Operation</i>
16 Sep 1975	03 Mar 1976	CVW-19	CV 34	WestPac
04 Oct 1975	19 Dec 1975	CVW-5	CV 41*	WestPac/IO
15 Oct 1975	05 May 1976	CVW-7	CV 62	NorLant/Med

\* *Midway* (CVA 41) with CVW-5 and its assigned squadrons were forward deployed and home ported overseas at Naval Station Yokosuka, Japan. Only operations outside the home waters of Japan are listed as deployments.

**Major Overseas Deployments for 1976**

<i>Date of Departure</i>	<i>Date of Return</i>	<i>Air Wing</i>	<i>Carrier</i>	<i>Area of Operation</i>
06 Jan 1976	28 Jul 1976	CVW-3	CV 60	Med
30 Jan 1976	07 Sep 1976	CVW-2	CV 61	WestPac/IO
13 Mar 1976	26 Apr 1976	CVW-5	CV 41*	WestPac
15 Apr 1976	25 Oct 1976	CVW-6	CV 66	Med
19 May 1976	22 Jun 1976	CVW-5	CV 41*	WestPac
07 Jul 1976	07 Feb 1977	CVW-8	CVN 68	Med
09 Jul 1976	04 Aug 1976	CVW-5	CV 41*	WestPac
30 Jul 1976	28 Mar 1977	CVW-14	CVN 65	WestPac/IO
02 Sep 1976	09 Nov 1976	CVW-1	CV 67	NorLant
04 Oct 1976	21 Apr 1977	CVW-19	CV 42	Med
01 Nov 1976	17 Dec 1976	CVW-5	CV 41*	WestPac

\* *Midway* (CV 41) with CVW-5 and its assigned squadrons were forward deployed and home ported overseas at Naval Station Yokosuka, Japan. Only operations outside the home waters of Japan are listed as deployments.

**Major Overseas Deployments for 1977**

<i>Date of Departure</i>	<i>Date of Return</i>	<i>Air Wing</i>	<i>Carrier</i>	<i>Area of Operation</i>
11 Jan 1977	01 Mar 1977	CVW-5	CV 41*	WestPac
15 Jan 1977	01 Aug 1977	CVW-1	CV 67	Med
15 Feb 1977	05 Oct 1977	CVW-15	CV 43	WestPac
31 Mar 1977	21 Oct 1977	CVW-7	CV 62	Med
12 Apr 1977	21 Nov 1977	CVW-9	CV 64	WestPac
19 Apr 1977	05 Sep 1977	CVW-5	CV 41*	WestPac
10 Jun 1977	19 Jul 1977	CVW-6	CV 66	SoLant
11 Jul 1977	23 Dec 1977	CVW-3	CV 60	Med
08 Aug 1977	02 Sep 1977	CVW-5	CV 41*	WestPac
27 Sep 1977	21 Dec 1977	CVW-5	CV 41*	WestPac/IO
29 Sep 1977	25 Apr 1978	CVW-6	CV 66	Med
25 Oct 1977	15 May 1978	CVW-11	CV 63	WestPac
01 Dec 1977	20 Jul 1978	CVW-8	CVN 68	Med/NorLant

\* *Midway* (CV 41) with CVW-5 and its assigned squadrons were forward deployed and home ported overseas at Naval Station Yokosuka, Japan. Only operations outside the home waters of Japan are listed as deployments.

**Major Overseas Deployments for 1978**

<i>Date of Departure</i>	<i>Date of Return</i>	<i>Air Wing</i>	<i>Carrier</i>	<i>Area of Operation</i>
04 Apr 1978	26 Oct 1978	CVW-17	CV 59	Med/NorLant
04 Apr 1978	30 Oct 1978	CVW-14	CVN 65	WestPac/IO
11 Apr 1978	23 May 1978	CVW-5	CV 41*	WestPac
29 Jun 1978	08 Feb 1979	CVW-1	CV 67	Med
26 Sep 1978	17 May 1979	CVW-9	CV 64	WestPac/IO
03 Oct 1978	05 Apr 1979	CVW-3	CV 60	Med
09 Nov 1978	23 Dec 1978	CVW-5	CV 41*	WestPac

\* *Midway* (CV 41) with CVW-5 and its assigned squadrons were forward deployed and home ported overseas at Naval Station Yokosuka, Japan. Only operations outside the home waters of Japan are listed as deployments.

**Major Overseas Deployments for 1979**

<i>Date of Departure</i>	<i>Date of Return</i>	<i>Air Wing</i>	<i>Carrier</i>	<i>Area of Operation</i>
11 Jan 1979	20 Feb 1979	CVW-5	CV 41*	WestPac
16 Jan 1979	13 Jul 1979	CVW-7	CVN 69	Med
21 Feb 1979	22 Sep 1979	CVW-2	CV 61	WestPac
13 Mar 1979	22 Sep 1979	CVW-11	CV 66	Med
07 Apr 1979	18 Jun 1979	CVW-5	CV 41*	IO
30 May 1979	25 Feb 1980	CVW-15	CV 63	WestPac/IO
28 Jun 1979	14 Dec 1979	CVW-6	CV 62	Med
20 Aug 1979	14 Sep 1979	CVW-5	CV 41*	WestPac
10 Sep 1979	26 May 1980	CVW-8	CVN 68	Med/SoLant/IO
30 Sep 1979	20 Feb 1980	CVW-5	CV 41*	IO
13 Nov 1979	11 Jun 1980	CVW-14	CV 43	WestPac/IO
27 Nov 1979	07 May 1980	CVW-17	CV 59	Med

\* *Midway* (CV 41) with CVW-5 and its assigned squadrons were forward deployed and home ported overseas at Naval Station Yokosuka, Japan. Only operations outside the home waters of Japan are listed as deployments.

**Major Overseas Deployments for 1980**

<i>Date of Departure</i>	<i>Date of Return</i>	<i>Air Wing</i>	<i>Carrier</i>	<i>Area of Operation</i>
26 Feb 1980	15 Oct 1980	CVW-9	CV 64	WestPac/IO
10 Mar 1980	27 Aug 1980	CVW-3	CV 60	Med
15 Apr 1980	22 Dec 1980	CVW-7	CVN 69	IO
14 Jul 1980	26 Nov 1980	CVW-5	CV 41*	WestPac/IO
04 Aug 1980	28 Mar 1981	CVW-1	CV 67	Med
29 Aug 1980	17 Oct 1980	CVW-8	CVN 68	NorLant
10 Sep 1980	05 May 1981	CVW-2	CV 61	WestPac/IO
19 Nov 1980	10 Jun 1981	CVW-6	CV 62	SoLant/IO/Med

\* *Midway* (CV 41) with CVW-5 and its assigned squadrons were forward deployed and home ported overseas at Naval Station Yokosuka, Japan. Only operations outside the home waters of Japan are listed as deployments.

**Major Overseas Deployments for 1981**

<i>Date of Departure</i>	<i>Date of Return</i>	<i>Air Wing</i>	<i>Carrier</i>	<i>Area of Operation</i>
23 Feb 1981	05 Jun 1981	CVW-5	CV 41*	WestPac/IO
02 Mar 1981	15 Sep 1981	CVW-17	CV 59	Med/NorLant

**Major Overseas Deployments for 1981—Continued**

<i>Date of Departure</i>	<i>Date of Return</i>	<i>Air Wing</i>	<i>Carrier</i>	<i>Area of Operation</i>
01 Apr 1981	23 Nov 1981	CVW-15	CV 63	WestPac/IO
14 Apr 1981	12 Nov 1981	CVW-11	CV 66	Med/IO
26 Jun 1981	16 Jul 1981	CVW-5	CV 41*	WestPac
03 Aug 1981	12 Feb 1982	CVW-8	CVN 68	Med
20 Aug 1981	07 Oct 1981	CVW-7	CVN 69	NorLant
20 Aug 1981	23 Mar 1982	CVW-14	CV 43	WestPac/IO
03 Sep 1981	06 Oct 1981	CVW-5	CV 41*	WestPac
20 Oct 1981	23 May 1982	CVW-9	CV 64	WestPac/IO

\* *Midway* (CV 41) with CVW-5 and its assigned squadrons were forward deployed and home ported overseas at Naval Station Yokosuka, Japan. Only operations outside the home waters of Japan are listed as deployments.

**Major Overseas Deployments for 1982**

<i>Date of Departure</i>	<i>Date of Return</i>	<i>Air Wing</i>	<i>Carrier</i>	<i>Area of Operation</i>
04 Jan 1982	14 Jul 1982	CVW-3	CV 67	Med/IO
05 Jan 1982	13 Jul 1982	CVW-7	CVN 69	Med
07 Apr 1982	19 Oct 1982	CVW-2	CV 61	WestPac/IO
26 Apr 1982	18 Jun 1982	CVW-5	CV 41*	WestPac
07 Jun 1982	22 Dec 1982	CVW-6	CV 62	Med
08 Jun 1982	16 Nov 1982	CVW-17	CV 59	Med/IO
23 Aug 1982	30 Oct 1982	CVW-1	CV 66	NorLant/Med/Carib
01 Sep 1982	28 Apr 1983	CVW-11	CVN 65	NorPac/WestPac
14 Sep 1982	11 Dec 1982	CVW-5	CV 41*	NorPac/WestPac
10 Nov 1982	20 May 1983	CVW-8	CVN 68	Carib/Med
08 Dec 1982	02 Jun 1983	CVW-1	CV 66	Med/IO

\* *Midway* (CV 41) with CVW-5 and its assigned squadrons were forward deployed and home ported overseas at Naval Station Yokosuka, Japan. Only operations outside the home waters of Japan are listed as deployments.

**Major Overseas Deployments for 1983**

<i>Date of Departure</i>	<i>Date of Return</i>	<i>Air Wing</i>	<i>Carrier</i>	<i>Area of Operation</i>
01 Mar 1983	29 Oct 1983	CVW-15	CVN 70	World Cruise
21 Mar 1983	12 Sep 1983	CVW-14	CV 43	World Cruise
27 Apr 1983	02 Dec 1983	CVW-7	CVN 69	Med
25 May 1983	01 Jul 1983	CVW-3	CV 67	NorLant
02 Jun 1983	08 Aug 1983	CVW-5	CV 41*	WestPac
15 Jul 1983	29 Feb 1984	CVW-9	CV 61	Central America/WestPac/IO
27 Sep 1983	02 May 1984	CVW-3	CV 67	SoLant/Med
25 Oct 1983	11 Dec 1983	CVW-5	CV 41*	WestPac
18 Oct 1983	11 Apr 1984	CVW-6	CV 62	Carib/Med/NorLant
28 Dec 1983	23 May 1984	CVW-5	CV 41*	IO

\* *Midway* (CV 41) with CVW-5 and its assigned squadrons were forward deployed and home ported overseas at Naval Station Yokosuka, Japan. Only operations outside the home waters of Japan are listed as deployments.

**Major Overseas Deployments for 1984**

<i>Date of Departure</i>	<i>Date of Return</i>	<i>Air Wing</i>	<i>Carrier</i>	<i>Area of Operation</i>
13 Jan 1984	01 Aug 1984	CVW-2	CV 63	WestPac/IO
02 Apr 1984	20 Oct 1984	CVW-17	CV 60	Med

**Major Overseas Deployments for 1984—Continued**

<i>Date of Departure</i>	<i>Date of Return</i>	<i>Air Wing</i>	<i>Carrier</i>	<i>Area of Operation</i>
24 Apr 1984	14 Nov 1984	CVW-1	CV 66	Carib/Med/IO
08 May 1984	20 Jun 1984	CVW-7	CVN 69	Carib/NorLant
30 May 1984	20 Dec 1984	CVW-11	CVN 65	WestPac/IO/NorPac
10 Oct 1984	08 May 1985	CVW-7	CVN 69	Med
18 Oct 1984	24 May 1985	CVW-15	CVN 70	NorPac/WestPac/IO
15 Oct 1984	12 Dec 1984	CVW-5	CV 41*	WestPac
16 Oct 1984	19 Feb 1985	CVW-6	CV 62	Med/IO

\* *Midway* (CV 41) with CVW-5 and its assigned squadrons were forward deployed and home ported overseas at Naval Station Yokosuka, Japan. Only operations outside the home waters of Japan are listed as deployments.

**Major Overseas Deployments for 1985**

<i>Date of Departure</i>	<i>Date of Return</i>	<i>Air Wing</i>	<i>Carrier</i>	<i>Area of Operation</i>
01 Feb 1985	28 Mar 1985	CVW-5	CV 41*	WestPac
21 Feb 1985	24 Aug 1985	CVW-14	CV 64	WestPac/IO
08 Mar 1985	04 Oct 1985	CVW-8	CVN 68	Carib/Med
10 Jun 1985	14 Oct 1985	CVW-5	CV 41*	IO/WestPac
08 Jul 1985	22 Aug 1985	CVW-7	CVN 69	Carib
24 Jul 1985	21 Dec 1985	CVW-9	CV 63	WestPac/IO
24 Aug 1985	09 Oct 1985	CVW-1	CV 66	NorLant
25 Aug 1985	16 Apr 1986	CVW-17	CV 60	Med/IO
01 Oct 1985	19 May 1986	CVW-13	CV 43	Med
15 Nov 1985	12 Dec 1985	CVW-5	CV 41*	WestPac

\* *Midway* (CV 41) with CVW-5 and its assigned squadrons were forward deployed and home ported overseas at Naval Station Yokosuka, Japan. Only operations outside the home waters of Japan are listed as deployments.

**Major Overseas Deployments for 1986**

<i>Date of Departure</i>	<i>Date of Return</i>	<i>Air Wing</i>	<i>Carrier</i>	<i>Area of Operation</i>
15 Jan 1986	12 Aug 1986	CVW-11	CVN 65	World Cruise
17 Jan 1986	30 Mar 1986	CVW-5	CV 41*	WestPac
10 Mar 1986	10 Sep 1986	CVW-1	CV 66	Med
02 Jun 1986	10 Nov 1986	CVW-6	CV 59	Med
12 Aug 1986	05 Feb 1987	CVW-15	CVN 70	NorPac/WestPac/IO
15 Aug 1986	16 Oct 1986	CVW-8	CVN 68	NorLant
18 Aug 1986	03 Mar 1987	CVW-3	CV 67	Med
18 Aug 1986	20 Oct 1986	CVW-2	CV 61	NorPac/WestPac
04 Sep 1986	20 Oct 1986	CVW-14	CV 64	NorPac
30 Dec 1986	26 Jul 1987	CVW-8	CVN 68	Med/SoLant/West Coast

\* *Midway* (CV 41) with CVW-5 and its assigned squadrons were forward deployed and home ported overseas at Naval Station Yokosuka, Japan. Only operations outside the home waters of Japan are listed as deployments.

**Major Overseas Deployments for 1987**

<i>Date of Departure</i>	<i>Date of Return</i>	<i>Air Wing</i>	<i>Carrier</i>	<i>Area of Operation</i>
03 Jan 1987	29 Jun 1987	CVW-9	CV 63	World Cruise
09 Jan 1987	20 Mar 1987	CVW-5	CV 41*	WestPac
02 Mar 1987	29 Apr 1987	CVW-2	CV 61	NorPac
11 Apr 1987	13 Oct 1987	CVW-14	CV 64	WestPac/IO

**Major Overseas Deployments for 1987—Continued**

<i>Date of Departure</i>	<i>Date of Return</i>	<i>Air Wing</i>	<i>Carrier</i>	<i>Area of Operation</i>
23 Apr 1987	13 Jul 1987	CVW-5	CV 41*	WestPac
05 Jun 1987	17 Nov 1987	CVW-17	CV 60	Med
14 Jul 1987	29 Dec 1987	CVW-2	CV 61	WestPac/IO
28 Aug 1987	09 Oct 1987	CVW-6	CV 59	NorLant
29 Sep 1987	28 Mar 1988	CVW-13	CV 43	Med
15 Oct 1987	12 Apr 1988	CVW-5	CV 41*	WestPac/IO
25 Oct 1987	24 Nov 1987	CVW-11	CVN 65	NorPac

\* *Midway* (CV 41) with CVW-5 and its assigned squadrons were forward deployed and home ported overseas at Naval Station Yokosuka, Japan. Only operations outside the home waters of Japan are listed as deployments.

**Major Overseas Deployments for 1988**

<i>Date of Departure</i>	<i>Date of Return</i>	<i>Air Wing</i>	<i>Carrier</i>	<i>Area of Operation</i>
05 Jan 1988	03 Jul 1988	CVW-11	CVN 65	WestPac/IO/NorPac
29 Feb 1988	29 Aug 1988	CVW-7	CVN 69	Med
25 Apr 1988	07 Oct 1988	CVW-6	CV 59	Med/IO/NorLant
15 Jun 1988	14 Dec 1988	CVW-15	CVN 70	NorPac/WestPac/IO
02 Aug 1988	01 Feb 1989	CVW-3	CV 67	Med
25 Aug 1988	11 Oct 1988	CVW-8	CVN 71	NorLant
02 Sep 1988	02 Mar 1989	CVW-9	CVN 68	WestPac/IO
18 Oct 1988	09 Nov 1988	CVW-5	CV 41*	WestPac
01 Dec 1988	01 Jun 1989	CVW-14	CV 64	WestPac/IO
30 Dec 1988	30 Jun 1989	CVW-8	CVN 71	Med

\* *Midway* (CV 41) with CVW-5 and its assigned squadrons were forward deployed and home ported overseas at Naval Station Yokosuka, Japan. Only operations outside the home waters of Japan are listed as deployments.

**Major Overseas Deployments for 1989**

<i>Date of Departure</i>	<i>Date of Return</i>	<i>Air Wing</i>	<i>Carrier</i>	<i>Area of Operation</i>
21 Jan 1989	24 Feb 1989	CVW-5	CV 41*	WestPac
08 Feb 1989	03 Apr 1989	CVW-1	CV 66	Carib/NorLant
24 Feb 1989	24 Aug 1989	CVW-2	CV 61	WestPac/IO
27 Feb 1989	09 Apr 1989	CVW-5	CV 41*	WestPac
11 May 1989	10 Nov 1989	CVW-1	CV 66	Med/IO
31 May 1989	25 Jul 1989	CVW-5	CV 41*	WestPac
31 May 1989	30 Sep 1989	CVW-13	CV 43	Med
15 Jun 1989	09 Jul 1989	CVW-9	CVN 68	NorPac
15 Aug 1989	11 Dec 1989	CVW-5	CV 41*	WestPac/IO
05 Sep 1989	09 Nov 1989	CVW-15	CVN 70	NorPac/WestPac
16 Sep 1989	19 Oct 1989	CVW-14	CV 64	NorPac
17 Sep 1989	16 Mar 1990	CVW-11	CVN 65	World Cruise
04 Nov 1989	12 Apr 1990	CVW-6	CV 59	Med

\* *Midway* (CV 41) with CVW-5 and its assigned squadrons were forward deployed and home ported overseas at Naval Station Yokosuka, Japan. Only operations outside the home waters of Japan are listed as deployments.



**Major Overseas Deployments for 1990**

<i>Date of Departure</i>	<i>Date of Return</i>	<i>Air Wing</i>	<i>Carrier</i>	<i>Area of Operation</i>
25 Jan 1990	06 Apr 1990	CVW-5	CV 41*	WestPac
01 Feb 1990	31 Jul 1990	CVW-15	CVN 70	WestPac/IO
08 Mar 1990	12 Sep 1990	CVW-7	CVN 69	Med/Red Sea
23 Jun 1990	20 Dec 1990	CVW-14	CV 62	WestPac/IO/Persian Gulf
07 Aug 1990	28 Mar 1991	CVW-17	CV 60	Med/Red Sea
15 Aug 1990	28 Mar 1991	CVW-3	CV 67	Med/Red Sea
02 Oct 1990	17 Apr 1991	CVW-5	CV 41*	WestPac/IO/Persian Gulf
08 Dec 1990	08 Jun 1991	CVW-2	CV 61	WestPac/IO/Persian Gulf
28 Dec 1990	18 Apr 1991	CVW-1	CV 66	Med/Red Sea/Persian Gulf
28 Dec 1990	28 Jun 1991	CVW-8	CVN 71	Med/Red Sea/Persian Gulf

\* *Midway* (CV 41) with CVW-5 and its assigned squadrons were forward deployed and home ported overseas at Naval Station Yokosuka, Japan. Only operations outside the home waters of Japan are listed as deployments.

# ***U.S. Navy Squadron Designations and Abbreviations***

**T**HE SYSTEM OF SQUADRON designations was established to help define part of naval aviation's organizational structure and help identify the operational and administrative functions of aviation within the fleet. Just as the designations for ships, such as DD, CA, BB, etc., were used to define the duties of the specific units and their alignment within the fleet organization, so also were the squadron designations established to formulate the responsibilities and alignment within naval aviation and the fleet structure.

During naval aviation's early years there were big question marks concerning naval aviation's ability to succeed as a functional component of the fleet and whether it would survive due to the limited capabilities of the aircraft. In official publications and references, such as the Daily Aviation News Bulletin of 1 October 1919, casual terms were used to describe or identify various aircraft squadrons and units. The casual terms were used because no specific fleet aviation organizational structure for squadrons had been officially established. Prior to 1919, naval aircraft, excluding Marine Corps planes, were primarily assigned to shore stations. Therefore, in order to integrate aviation into the fleet, it was necessary to develop a fleet organization that included aviation units. The development of a system of squadron designations is discussed in Chapter 1.

In general terms, the Navy's system for designating naval aircraft squadrons has usually conformed to the following loose classification structure:

- (1) Squadron designations were based on specific letters used for indicating the missions for each particular type of squadron and its assigned aircraft. As an example, a World War II squadron operating the F4U Corsair aircraft would have been designated a fighting squadron (VF). The letter F, for fighting or fighter, was the key in identifying the type of squadron and was also used in the aircraft's designation.
- (2) Identification numbers were assigned to each squadron, such as VF-1. The number 1 separates Fighter Squadron 1 (VF-1) from Fighter Squadron 10 (VF-10).

There have been many variations to this basic system throughout naval aviation's history. Changes were

also made to the designation system when new plane types were developed and new squadrons were formed to carry out those new missions. There is no logical sequence for the numerical designation assigned the various squadrons throughout most of naval aviation's history. The Marine Corps did establish a logical sequence for their squadron designations, however, there are variations to this system, too.

As Navy squadrons were established, disestablished or redesignated, many of the same letters and numbers were reused and assigned at a later date for newly established or redesignated units, hence, the lineage of a squadron cannot always be traced or linked by using the same designation. As an example, VF-1 from World War II has no direct relationship to VF-1 established in the 1970s. The rich tradition and heritage of the various squadrons in the Navy has not always been carried over because of the break in continuity between units. Once a squadron is disestablished that ends its history. If a new squadron is established using the same designation of a previous squadron it does not have any direct relationship with that unit. The reuse of many of the same letters and numerical designations adds considerable confusion to the squadron designation system. A new squadron may carry on the traditions of a previous squadron, just as a ship that has been assigned the same name more than once carries on the traditions of the past ships with the same name. However, a squadron, just like a ship, can not claim a heritage or historical link to the old unit with the same designation.

Consistency has been the major ingredient lacking in the Navy's squadron designation system. As an example, the use of "Plane" in squadron designations was not consistent during the 1920s. Sometimes the full designation would be written differently, depending on the squadron's assignment to the Battle Fleet, Scouting Fleet, or Asiatic Fleet. A designation such as Scouting Squadron and Scouting Plane Squadron, which used the same abbreviation, VS, was listed in the *Navy Directory* as Scouting Squadron under the Battle Fleet and Scouting Plane Squadron under the Scouting Fleet. The use of "Plane" in squadron designations was most likely designed to identify the squadron as an aviation unit, vice a destroyer squadron. This seems to be especially true during the

1920s when aviation was first being integrated into the fleet organization and operations. The *Navy Directory*; *Monthly Report, Status of Naval Aircraft*; and the *Bureau of Aeronautics, Weekly Newsletter* all list squadron designations using “Plane.” The Chief of Naval Operations’ *Naval Aeronautical Organization*, published for each Fiscal Year, lists the squadron designations without using “Plane” in the designation. It is obvious there is no difference between the squadrons with or without the use of “Plane” in the squadron designation. The acronym remained the same, with or without the use of “Plane” in the full squadron designation. In the 1930s the squadron designations listed in all four sources identified above usually refer to the squadron using its abbreviated designation, such as VF Squadron 1 (VF-1) instead of Fighting Plane Squadron 1. In the 1940s the use of “Plane” in the full squadron designation is dropped.

In the late 1940s and early 1950s the VC squadron designation was used to identify a group of squadrons with several different missions but all assigned the VC designation. Missions for specific Composite Squadrons (VC) included all-weather night, attack and defense; air early warning; anti-submarine warfare; and photographic. The only identifying factor to separate the different types of Composite Squadrons was the numerical designation. In the late 1940s the single digit numbers were for the Composite Night or Attack and Defense units, those numbers in the teens were for Composite Air Warning squadrons, numbers in the 20s and 30s were for Composite Anti-Submarine units, and the numbers in the 60s were for Composite Photographic squadrons.

Besides the composite squadrons (VC), several patrol squadrons (VP) had specific mission requirements that were different from its normal patrol and reconnaissance duties. However, these squadrons still maintained the normal VP designation. In the late 1940s there were two VP squadrons with a primary mission of photographic and one with an air early warning mission. VP-61 and VP-62 were the photographic squadrons and VP-51 was the air early warning squadron.

The special VC and VP designated units, were on the cutting edge of technology, which eventually lead to the development of specialized squadron designations in the 1950s and 1960s. Squadrons such as VAW (Carrier Airborne Early Warning), VAQ (Tactical Electronic Warfare), and VQ (Electronic Countermeasures or Air Reconnaissance) were the result of technical developments in the late 1940s and early 1950s.

The use of an abbreviated squadron designation with different missions occurred in the early 1950s when the VJ designation was used for both photographic squadrons and weather squadrons. VJ-1 and 2 were designated Weather Squadrons or Weather Reconnaissance Squadrons. VJ-61 and 62 were designated Photographic Squadrons. The missions were totally

different for these two types of squadrons but they used a common abbreviated squadron designation.

There are four factors that play a role in developing or changing squadron designations. They have been around since the introduction of aviation in the Navy and will continue to be the primary factors effecting squadron designations. The factors are:

1. the duties or mission of a squadron
2. technical advances in aircraft or equipment
3. changes in tactics or development of new tactics
4. changes in naval aviation or fleet organization

The following is a list of various squadron designations used by the Navy since the early 1920s. It does not include Marine Corps squadron designations. The list is in alphabetical order rather than in the chronological order of squadron development. The general time frame for when the designation was in use is listed with the squadron designation. Further elaboration on the assignment of squadrons to other organizations and their designations such as: a battle group, carrier air wing, cruiser group, fleet air force, scouting fleet, Asiatic Fleet, naval district, reserves, etc..., has not been included in this list to prevent it from becoming to confusing or extensive. The only exception to this is for the reserves. Reserve squadron designations, beginning in 1970, are included in this list. In 1970 the naval air reserve was reorganized and the squadron structure and arrangement was aligned to mirror the squadron designation system in existence for active fleet units.

### **U.S. NAVY SQUADRON DESIGNATIONS AND ABBREVIATIONS**

<i>Acronym</i>	<i>Full Squadron Designation</i>	<i>General time-frame in use</i>
HAL or HA(L)	Helicopter Attack Squadron Light	1967-1972 1976-1988
HC	Helicopter Combat Support Squadron	1965-present
HCS	Helicopter Combat Support Special Squadron	1988-present
HCT	Helicopter Combat Support Training Squadron	1974-1977
HM	Helicopter Mine Countermeasures Squadron	1971-present
HS	Helicopter Anti-Submarine Squadron	1951-present
HSL	Helicopter Anti-Submarine Squadron (Light)	1972-present
HT	Helicopter Training Squadron	1960-present
HTU	Helicopter Training Unit	1950-1957
HU	Helicopter Utility Squadron	1948-1965
RVAH	Reconnaissance Attack Squadron	1964-1979
RVAW	Carrier Airborne Early Warning Training Squadron	1967-1983
STAGRON	Special Air Task Force Squadron (VK)	1943-1944
TACRON	Tactical Squadron or Tactical Air Control Squadron or Tactical Control Squadron	1946-present
VA	Attack Squadron	1946-present
VA(AW)	All-Weather Attack Squadron	1956-1959
VAH or VA(H)	Heavy Attack Squadron	1955-1971
VA(HM)	Attack Mining Squadron	1956-1959

**U.S. NAVY SQUADRON DESIGNATIONS AND ABBREVIATIONS—Continued**

<i>Acronym</i>	<i>Full Squadron Designation</i>	<i>General time-frame in use</i>
VAK	Tactical Aerial Refueling Squadron	1979-1989
VAL or VA(L)	Light Attack Squadron	1969-1972
VAP or VA(P)	Heavy Photographic Reconnaissance Squadron or Photographic Reconnaissance Squadron (Heavy) or Heavy Photographic Squadron	1956-1971
VAQ	Carrier Tactical Electronics Warfare Squadron or Tactical Electronics Warfare Squadron	1968-present
VAW	Carrier Airborne Early Warning Squadron	1948 1956-present
VAW	Carrier Tactical Electronics Warfare Squadron	1968
VB	Bombing Squadron or Light Bombing Plane Squadron	1928-1946
VBF	Bombing Fighting Squadron	1945-1946
VC	Composite Squadron	1943-1945 1948-1956
VC	Fleet Composite Squadron	1965-present
VCN	Night Composite Squadron	1946-1948
VCP	Photographic Composite Squadron	1959-1961
VCS	Cruiser Scouting Squadron	1937-1945
VD	Photographic Squadron	1943-1946
VE	Evacuation Squadron	1944-1945
VF	Combat Squadron	1922
VF	Fighting Plane Squadron or Fighting Squadron	1922-1948
VF	Fighter Squadron	1948-present
VFA	Fighter Attack Squadron	1980-1983
VFA	Strike Fighter Squadron	1983-present
VF(AW)	All-Weather Fighter Squadron or Fighter (All-Weather) Squadron	1956-1963
VFN or VF(N)	Night Fighting Squadron	1944-1946
VFP or VF(P)	Light Photographic Reconnaissance Squadron or Photographic Reconnaissance Squadron or Photographic Reconnaissance Squadron (Light) or Light Photographic Squadron	1956-1987
VGF	Escort-Fighter Squadron	1942-1943
VGS	Escort-Scouting Squadron	1942-1943
VH	Rescue Squadron	1944-1946
VJ	Utility Squadron or General Utility Squadron	1925-1946
VJ	Weather Squadron or Weather Reconnaissance Squadron	1952-1953
VJ	Photographic Squadron	1952-1956
VK	Special Air Task Force Squadron (STAGRON)	1943-1944
VN	Training Squadron	1927-1947
VO	Spotting Squadron	1922
VO	Observation Plane Squadron or Observation Squadron	1923-1945 1947-1949 1967-1968
VOC	Composite Spotting Squadron	1944-1945
VOF	Observation Fighter Squadron	1942-1945
VP	Seaplane Patrol Squadron	1922
VP	Patrol Squadron	1924-1944 1946 1948-present
VP-AM	Amphibian Patrol Squadron	1946-1948

**U.S. NAVY SQUADRON DESIGNATIONS AND ABBREVIATIONS—Continued**

<i>Acronym</i>	<i>Full Squadron Designation</i>	<i>General time-frame in use</i>
VPB	Patrol Bombing Squadron	1944-1946
VP-HL	Heavy Patrol Squadron (landplane)	1946-1948
VPM	Meteorological Squadron	1946-1947
VP-ML	Medium Patrol Squadron (landplane)	1946-1948
VP-MS	Medium Patrol Squadron (seaplane)	1946-1948
VPP or VP(P)	Photographic Squadron or Patrol Squadron (photographic)	1946-1948
VPU	Patrol Squadron Special Unit	1982-present
VPW	Weather Reconnaissance Squadron	1945-1948
VPW	Air Early Warning Squadron	1948
VQ	Electronic Countermeasures Squadron	1955-1960
VQ	Fleet Air Reconnaissance Squadron	1961-present
VR	Transport Squadron or Air Transport Squadron or Fleet Logistic Air Squadron	1942-1958
VR	Fleet Tactical Support Squadron	1958-1976
VR	Fleet Logistics Support Squadron	1976-present
VRC or VR(C)	Fleet Tactical Support Squadron	1960-1976
VRC	Fleet Logistics Support Squadron	1976-present
VRE	Air Transport Evacuation Squadron	1945
VRF	Transport Ferry and Service Squadron	1943-1946
VRF	Air Ferry Transport Squadron or Air Ferry Squadron	1943-1948
VRF or VR(F)	Aircraft Ferry Squadron	1957-1986
VRJ	Utility Transport Squadron	1945-1946
VRS	Air Ferry Service Squadron or Ferry Command Service Squadron	1943-1946
VRU	Transport Utility Squadron	1946-1948
VS	Scouting Plane Squadron or Scouting Squadron	1922-1946
VS	Anti-Submarine Squadron or Air Anti-Submarine Squadron or Carrier Air Anti-Submarine Squadron	1950-1993
VS	Sea Control Squadron	1993-present
VSF	Anti-Submarine Fighter Squadron	1965-1973
VT	Torpedo & Bombing Plane Squadron or Torpedo & Bombing Squadron	1922-1930
VT	Torpedo Plane Squadron	1921
VT	Torpedo Squadron	1930-1946
VT	Training Squadron	1960-present
VTN	Night Torpedo Squadron	1944-1946
VU	Utility Squadron	1946-1965
VW	Air Early Warning Squadron or Airborne Early Warning Squadron or Fleet Early Warning Squadron	1952-1971
VW	Weather Reconnaissance Squadron or Fleet Weather Reconnaissance Squadron	1967-1975
VX	Experimental Squadron	1927-circa 1943
VX	Experimental and Development Squadron or Operational Development Squadron or Air Operational Development Squadron or Air Development Squadron	1946-1968
VX	Air Test and Evaluation Squadron	1969-present
VXE	Antarctic Development Squadron	1969-present
VXN	Oceanographic Development Squadron	1969-1993
ZJ	Blimp Utility Squadron	1944-1945
ZK	Kite Balloon Squadron	1922-1924
ZKN	Kite Balloon Training Squadron	*
ZKO	Kite Balloon Observation Squadron	*
ZNN	Non-rigid Airship Training Squadron	*

**U.S. NAVY SQUADRON DESIGNATIONS AND  
ABBREVIATIONS—Continued**

<i>Acronym</i>	<i>Full Squadron Designation</i>	<i>General time- frame in use</i>
ZNO	Non-rigid Airship Observation Squadron	*
ZNP	Non-rigid Airship Patrol Squadron	*
ZNS	Non-rigid Airship Scouting Squadron	*
ZP	Airship Patrol Squadron	1942-1961
ZP	Blimp Squadron	1942-1961
ZP	Airship Patrol Squadron (All-Weather Anti-Submarine) or Airship Squadron or LTA Patrol Squadron	1942-1961
ZRN	Rigid Airship Training Squadron	*
ZRP	Rigid Airship Patrol Squadron	*

**U.S. NAVY SQUADRON DESIGNATIONS AND  
ABBREVIATIONS—Continued**

<i>Acronym</i>	<i>Full Squadron Designation</i>	<i>General time- frame in use</i>
ZRP	Rigid Airship Patrol Squadron	*
ZRS	Rigid Airship Scouting Squadron	*
ZS	Airship Anti-Submarine Squadron	*
ZW	Airship Early Warning Squadron	1956-1961
ZX	Airship Operational Development Squadron or Airship Development Squadron	1950-1957

\* These squadron designations were developed, however, the Navy never established any squadrons using the designations.

## How to Trace Squadron Lineage

**T**HE LINEAGE AND HISTORY of U.S. naval aviation squadrons has been a source of confusion since the birth of naval aviation in 1911. Much of this confusion arose from the terminology used by the Navy, the lack of a consistent policy in selecting the alphanumeric designations for squadrons; constantly reusing the same letter and numeric designations; and the many establishments, redesignations and disestablishments of aviation squadrons.

When dealing with a squadron's lineage, the only correct terms to use are establishment, disestablishment and redesignation. The terms commissioning and establishment have been used interchangeably for years and that is incorrect. Only ships are commissioned, decommissioned and receive commissioning pennants. Squadrons have establishment and disestablishment ceremonies.

A unit's history and lineage begins when it is established and ends at the time it is disestablished. Determining a squadron's "family tree" may seem cut and dried, but that is not the case. A squadron may undergo numerous redesignations during the period between its establishment and disestablishment. A newly established squadron bearing the same designation of a unit that had previously existed may carry on the traditions of the old organization but it cannot claim the history or lineage of the previous unit. The same is true of U. S. Navy ships and, thus, the rationale for such a policy becomes apparent. For example, *Ranger* (CV 61) is the seventh ship to bear the name *Ranger* and may carry on the traditions of the previous six ships. *Ranger* (CV 61) is obviously not the same Continental Navy Ship *Ranger* commanded by Captain John Paul Jones during the War of Independence. The history of *Ranger* (CV 61) begins with its commissioning date, not with the commissioning date of the first *Ranger*.

The most recent squadron with the designation Fighter Squadron One (VF-1) was established 1 October 1972 and disestablished 1 October 1993. It was the seventh squadron in the Navy to be designated VF-1. This squadron is not the same VF-1 that used the designation for the first time in 1922. Designations, like ship's names, are reused again and again. If there is a break in the active status of a unit designation as a result of a disestablishment, then there is no connection between the units bearing the same designation.

Another common problem area involves squadron

insignia. The lineage or history of a squadron cannot be traced using only its insignia, because the same insignia may have been adopted and approved for official use by more than one squadron during different time frames. The insignia of a disestablished squadron may be officially approved for use by another squadron but this does not confer upon the new squadron the right to the previous unit's history and lineage. The following outline of the Jolly Roger insignia is an example of the confusion that results if one attempts to trace the lineage and history of a squadron insignia without considering other factors.

VF-17 was established on 1 January 1943, and during World War II it produced an outstanding record as a fighter squadron. The Jolly Roger insignia for VF-17 was adopted during World War II. On 15 November 1946, all Navy squadrons were redesignated and VF-17 became VF-5B. Subsequently, it was redesignated VF-61 on 28 April 1948, and then disestablished on 15 April 1959. Commander Hoppe was the Commanding Officer of VF-61 when it was disestablished. The Jolly Roger insignia had been used by VF-17/VF-5B/VF-61 from 1943 until 15 April 1959.

On 2 July 1955, VA-86 was established and on the same day was redesignated VF-84. This squadron was equipped with the FJ Fury and adopted the nickname Vagabonds. An insignia consisting of a lightning bolt striking the world in the area of Norfolk, with a sword behind the bolt, was approved on 27 September 1955. The squadron operated under this name and insignia until it replaced the FJs with F8U Crusaders in 1959. Commander Hoppe assumed command of VF-84 two days after the disestablishment of VF-61, the Jolly Roger squadron. He initiated the request to have VF-84 adopt the old Jolly Roger insignia, which had been used by VF-61 and was no longer active. This request was approved by CNO on 1 April 1960. There is no direct connection between the former Jolly Roger squadron (VF-17/VF-5B/VF-61) and VF-84, which adopted the Jolly Roger insignia. To further complicate a review of the records, there have been other squadrons with the designation VF-84. During World War II, a VF-84 was established on 1 May 1944, and disestablished 8 October 1945. Naval air reserve squadron VF-921 was called to active duty 1 February 1951, and was redesignated VF-84 on 4 February 1954. This squadron then became VA-86 on 2 July 1955. This occurred on the same day, the current Jolly Roger

squadron was established as VA-86 and immediately redesignated VF-84. Neither of these two VF-84 squadrons had any connection with the original Jolly Rogers. Thus, the present VF-84 operating with the insignia and title of Jolly Rogers can lay claim to the traditions of VF-17, VF-5B and VF-61, if it wishes to do so, but can only claim a history which commenced on 2 July 1955, and it is not a direct descendant of the original Jolly Rogers squadron.

A squadron's history and lineage covers only the period during which a unit is officially declared active (established by CNO), has personnel assigned to it, and is listed in the Naval Aeronautical Organization. When a squadron is disestablished, its history and lineage ends. If a squadron is redesignated while it is active, the lineage and history of the unit is carried on by the newly redesignated squadron. The following is an example of what occurs when a squadron is redesignated and its lineage and history remain unbroken.

The current VFA-25 was originally established as Torpedo Squadron 17 (VT-17) on 1 January 1943. On 15 November 1946, VT-17 was redesignated VA-6B and carried this designation until 27 April 1948, when it was redesignated VA-65. On 1 July 1959, VA-65 was redesignated VA-25 and the unit remained Attack

Squadron 25 until it was redesignated VFA-25 on 1 July 1983. The history and lineage of the present VFA-25 may be traced to 1 January 1943, because there was no break in active duty status of the squadron, even though its designation changed four times.

The current VFA-106 provides an example of what happens when a squadron is disestablished and then, years later, the same number is used again. This squadron was established at NAS Cecil Field on 27 April 1984. VFA-106 adopted the old insignia of VA-106 and had it officially approved. The squadron may carry on the traditions of the old VA-106, but it cannot trace its lineage and history back to VA-106. The list of commanding officers for VA-106 is not part of the list of commanding officers for VFA-106. The history of VA-106 came to an end on 7 November 1969, when it was disestablished and its personnel were transferred to other duty stations. At this time, VA-106 was removed from the active list in the Naval Aeronautical Organization.

Appendix 6 in this book will provide the lineage listing for all squadrons that have been assigned the VA, VA(AW), VAH, VA(HM), VAK, VAL, VAP, and VFA designations.

## APPENDIX 6

# Lineage Listing for VA, VA(AW), VAH, VA(HM), VAK, VAL, VAP, and VFA Designated Squadrons

**T**HE FOLLOWING LINEAGE LIST of squadrons will identify every VA, VA(AW), VAH, VA(HM), VAK, VAL, VAP and VFA designated squadron the Navy has had in existence, with the exception of Reserve squadrons prior to 1970. If a squadron was assigned another unit designation other than the designation series listed above, then information giving a cross reference to a different designation series will be provided, such as "See VF-45's history records." As an example, the lineage for the third squadron assigned the VA-45 designation is as follows:

Established as VA-45 on 24 May 1955  
 VA-45 redesignated VF-45 on 7 February 1985  
 (See VF-45 history records)

Squadron histories in this book will cover only those units that are still assigned the VA or VFA designations or were disestablished when they were assigned the VA, VAH, VAK, VAL, VAP or VFA designations. Consequently, the squadron history for the third VA-45 squadron is not in this book because the history of the squadron belongs with the current VF-45 squadron. The squadron history for VF-45 will be written and placed in a future volume dealing with the Fighter Squadrons.

The year 1990 was arbitrarily selected as the cutoff date for concluding the active squadron histories. Squadron histories were extended beyond the 1990 date if a squadron was disestablished or redesignated prior to the book's going to press.

The aircraft listing in Appendix 7 identifies the types of planes used by the squadrons listed below. The individual aircraft assignment for each squadron is listed in the squadron's history.

### Attack Squadrons (VA)

<i>Squadron Designation</i>	<i>Lineage</i>	<i>Action Date</i>
VA-1A	(See VA-14)	
VA-1B	(See VA-24)	
VA-1E	Est. as VT-41	26 Mar 1946
	VT-41 redesign. VA-1E	15 Nov 1946
	VA-1E disest.	01 Sep 1948
VA-1L	Est. as VT-58	19 Mar 1946

### Attack Squadrons (VA)—Continued

<i>Squadron Designation</i>	<i>Lineage</i>	<i>Action Date</i>
	VT-58 redesign. VA-1L	15 Nov 1946
	VA-1L disest.	20 Nov 1948
VA-2A	(See 1st VA-15)	
VA-2B	(See 2nd VA-65)	
VA-2E	Est. as VT-42	19 Jul 1945
	VT-42 redesign. VA-2E	15 Nov 1946
	VA-2E redesign. VC-22	01 Sep 1948
	VC-22 redesign. VS-22	20 Apr 1950
	VS-22 disest.	01 Jun 1956
	(See VS-22 history records)	
VA-3A	(See 2nd VA-35)	
VA-3B	(See 1st VA-44)	
VA-3E	Est. as VA-3E	21 Apr 1947
	VA-3E redesign. VC-23	01 Sep 1948
	VC-23 redesign. VS-23	23 Apr 1950
	VS-23 disest.	27 Sep 1968
	(See VS-23 history records)	
VA-4A	(See 1st VA-35)	
VA-4B	(See 1st VA-45)	
VA-5A	(See 1st VA-54)	
VA-5B	(See 1st VA-64)	
VA-6A	(See 1st VA-55)	
VA-6B	(See VFA-25)	
VA-7A	(See 2nd VA-75)	
VA-8A	(See 1st VA-75)	
VA-9A	(See 1st VA-94)	
VA-10A	(See 1st VA-95)	
VA-11A	(See VA-114)	
VA-12	Est. as VBF-4	12 May 1945
	VBF-4 redesign. VF-2A	15 Nov 1946
	VF-2A redesign. VF-12	02 Aug 1948
	VF-12 redesign. VA-12	01 Aug 1955
	VA-12 disest.	01 Oct 1986
	(See VA-115)	
VA-12A	(See 2nd VA-174)	
VA-13A	Est. as Air detachment,	
VA-14	Pacific Fleet	Sep 1919
	Became VT-5, an element of Air detachment,	
	Pacific Fleet	15 Jun 1920
	VT-5 redesign. VP-4-1	07 Sep 1921
	VP-4-1 redesign. VF-4	23 Sep 1921
	VF-4 redesign. VF-1	01 Jul 1922
	VF-1 redesign. VF-1B	01 Jul 1927
	VF-1B redesign. VB-2B	01 Jul 1934
	VB-2B redesign. VB 3	01 Jul 1937
	VB-3 redesign. VB-4	01 Jul 1939
	VB-4 redesign. VS-41	15 Mar 1941



**Attack Squadrons (VA)—Continued**

<i>Squadron Designation</i>	<i>Lineage</i>	<i>Action Date</i>
	VS-41 redesign. VB-41	01 Mar 1943
	VB-41 redesign. VB-4	04 Aug 1943
	VB-4 redesign. VA-1A	15 Nov 1946
	VA-1A redesign. VA-14	02 Aug 1948
	VA-14 redesign. VF-14	15 Dec 1949
	(See VF-14 history records)	
VA-14A	(See 1st VA-135)	
(1st) VA-15	Est. as VT-4	10 Jan 1942
	VT-4 redesign. VA-2A	15 Nov 1946
	VA-2A redesign. VA-15	02 Aug 1948
	VA-15 disest.	01 Jun 1969
(2nd) VA-15	(See VFA-15)	
VA-15A	(See VA-154)	
VA-16	Est. as VA-16	01 Jun 1955
	VA-16 disest.	01 Mar 1958
VA-16A	(See 1st VA-155)	
VA-17A	(See 1st VA-174)	
VA-18A	(See VA-175)	
VA-19A	(See VA-194)	
VA-20A	(See VFA-195)	
VA-21A	Est. as VB-98	28 Aug 1944
	VB-98 redesign. VA-21A	15 Nov 1946
	VA-21A disest.	05 Aug 1947
VA-22	(See VFA-22)	
VA-22A	Est. as VT-98	28 Aug 1944
	VT-98 redesign. VA-22A	15 Nov 1946
	VA-22A disest.	05 Aug 1947
VA-23	Called to Active duty as VF-653	01 Feb 1951
	VF-653 redesign. VF-151	04 Feb 1953
	VF-151 redesign. VA-151	07 Feb 1956
	VA-151 redesign. VA-23	23 Feb 1959
	VA-23 disest.	01 Apr 1970
VA-24	Est. as VB-74	01 May 1945
	VB-74 redesign. VA-1B	15 Nov 1946
	VA-1B redesign. VA-24	01 Sep 1948
	VA-24 redesign. VF-24	01 Dec 1949
	VF-24 redesign. VF-211	09 Mar 1959
	(See VF-211 history records)	
(1st) VA-25	(See 2nd VA-65 lineage)	
(2nd) VA-25	(See VFA-25)	
VA-26	(See 2nd VA-125)	
VA-27	(See VFA-27)	
VA(AW)-33	Est. as VC-33	31 May 1949
	VC-33 redesign. VA(AW)-33	02 Jul 1956
	VA(AW)-33 redesign. VAW-33	30 Jan 1959
	VAW-33 redesign. VAQ-33	01 Feb 1968
	(See VAQ-33 history records)	
(1st) VA-34	(See 2nd VA-35 lineage)	
(2nd) VA-34	Est. as VF-20	15 Oct 1943
	VF-20 redesign. VF-9A	15 Nov 1946
	VF-9A redesign. VF-91	12 Aug 1948
	VF-91 redesign. VF-34	15 Feb 1950
	VF-34 redesign. VA-34	01 Jul 1955
	VA-34 disest.	01 Jun 1969
(3rd) VA-34	Est.	01 Jan 1970
(1st) VA-35	Est. as VT-2	1925

**Attack Squadrons (VA)—Continued**

<i>Squadron Designation</i>	<i>Lineage</i>	<i>Action Date</i>	
	VT-2 redesign. VT-2B	01 Jul 1927	
	VT-2B redesign. VT-3	01 Jul 1937	
	VT-3 redesign. VA-4A	15 Nov 1946	
	VA-4A redesign. VA-35	07 Aug 1948	
	VA-35 disest.	07 Nov 1949	
(2nd) VA-35	Est. as VB-3B	01 Jul 1934	
	VB-3B redesign. VB-4	01 Jul 1937	
	VB-4 redesign. VB-3	01 Jul 1939	
	VB-3 redesign. VA-3A	15 Nov 1946	
	VA-3A redesign. VA-34	07 Aug 1948	
	VA-34 redesign. VA-35	15 Feb 1950	
	VA(AW)-35 (See VA-122)		
(1st) VA-36	Est. as VF-102	01 May 1952	
	VF-102 redesign. VA-36	01 Jul 1955	
	VA-36 disest.	01 Aug 1970	
(2nd) VA-36	Est. as VA-36	06 Mar 1987	
	VA-36 disest.	01 Apr 1994	
	VA-37 (See VFA-37)		
	VA-38	Est. as VA-38	01 Mar 1967
		VA-38 disest.	01 Oct 1968
	VA-42	Est. as VF-42	01 Sep 1950
		VF-42 redesign. VA-42	01 Nov 1953
		VA-42 disest.	30 Sep 1994
	VA-43	Est. as VF-74A	01 May 1945
		VF-74A redesign. VF-74	01 Aug 1945
		VF-74 redesign. VF-1B	5 Nov 1946
		VF-1B redesign. VF-21	01 Sep 1948
		VF-21 redesign. VA-43	01 Jul 1959
		VA-43 redesign. VF-43	01 Jun 1973
		(See VF-43 history records)	
(1st) VA-44	Est. as VB-75	01 Jun 1945	
	VB-75 redesign. VA-3B	15 Nov 1946	
	VA-3B redesign. VA-44	01 Sep 1948	
	VA-44 disest.(believe to be	8 Jun 1950)	
(2nd) VA-44	Est. as VF-44	01 Sep 1950	
	VF-44 redesign. VA-44	01 Jan 1956	
	VA-44 disest.	01 May 1970	
(1st) VA-45	Est. as VT-75	01 Jun 1945	
	VT-75 redesign. VA-4B	15 Nov 1946	
	VA-4B redesign. VA-45	01 Sep 1948	
	VA-45 disest.	08 Jun 1950	
(2nd) VA-45	Est. as VA-45	01 Sep 1950	
	VA-45 disest.	01 Mar 1958	
(3rd) VA-45	Est. as VA-45	15 Feb 1963	
	VA-45 redesign. VF-45	07 Feb 1985	
	(See VF-45 history records)		
	VA-46	Est. as VA-46	24 May 1955
	VA-46 disest.	30 Jun 1991	
	VA-52	Reserve sqd. VF-884 called to active duty	20 Jul 1950
		VF-884 redesign. VF-144	04 Feb 1953
		VF-144 redesign. VA-52	23 Feb 1959
(1st) VA-54	Est. as VS-2B	03 Jul 1928	
	VS-2B redesign. VS-3	01 Jul 1937	
	VS-3 redesign. VB-4	01 Mar 1943	
	VB-4 redesign. VB-5	15 Jul 1943	
	VB-5 redesign. VA-5A	15 Nov 1946	
	VA-5A redesign. VA-54	16 Aug 1948	

**Attack Squadrons (VA)—Continued**

<i>Squadron Designation</i>	<i>Lineage</i>	<i>Action Date</i>
	VA-54 disest.	01 Dec 1949
(2nd) VA-54	Est. as VBF-153	26 Mar 1945
	VBF-153 redesign. VF-16A	15 Nov 1946
	VF-16A redesign. VF-152	15 Jul 1948
	VF-152 redesign. VF-54	15 Feb 1950
	VF-54 redesign. VA-54	15 Jun 1956
(1st) VA-55	VA-54 disest.	01 Apr 1958
	Est. as VT-5	15 Feb 1943
	VT-5 redesign. VA-6A	15 Nov 1946
	VA-6A redesign. VA-55	16 Aug 1948
	VA-55 disest.	12 Dec 1975
(2nd) VA-55	Est. as VA-55	07 Oct 1983
	VA-55 disest.	01 Jan 1991
VA-56	Est. as VA-56	04 Jun 1956
	VA-56 disest.	31 Aug 1986
VA-63	(See VFA-22)	
(1st) VA-64	Est. as VB-17	01 Jan 1943
	VB-17 redesign. VA-5B	15 Nov 1946
	VA-5B redesign. VA-64	27 Jul 1948
	VA-64 redesign. VC-24	08 Apr 1949
	VC-24 redesign. VS-24	20 Apr 1950
	VS-24 disest.	01 Jun 1956
	(See VS-24 history records)	
(2nd) VA-64	Est. as VA-64	01 Jul 1961
	VA-64 disest.	07 Nov 1969
(1st) VA-65	(See VFA-25)	
(2nd) VA-65	Est. as VT-74	01 May 1945
	VT-74 redesign. VA-2B	15 Nov 1946
	VA-2B redesign. VA-25	01 Sep 1948
	VA-25 redesign. VA-65	01 Jul 1959
	VA-65 disest.	31 Mar 1993
(1st) VA-66	(See VFA-81)	
(2nd) VA-66	Reserve sqd. VF-671 called to active duty	01 Feb 1951
	VF-671 redesign. VF-81	04 Feb 1953
	VF-81 redesign. VA-66	01 Jul 1955
	VA-66 disest.	01 Oct 1986
	Note: VA-66 Det continued in existence until	31 Mar 1987
VA-67	(See VFA-15)	
VA 72	Est. as VBF-18	25 Jan 1945
	VBF-18 redesign. VF-8A	15 Nov 1946
	VF-8A redesign. VF-72	28 Jul 1948
	VF-72 redesign. VA-72	03 Jan 1956
	VA-72 disest.	30 Jun 1991
VA 74	(See 2nd VA-75)	
(1st) VA-75	Est. as VT-18	20 Jul 1943
	VT-18 redesign. VA-8A	15 Nov 1946
	VA-8A redesign. VA-75	27 Jul 1948
	VA-75 disest.	30 Nov 1949
(2nd) VA-75	Est. as VB-18	20 Jul 1943
	VB-18 redesign. VA-7A	15 Nov 1946
	VA-7A redesign. VA-74	27 Jul 1948
	VA-74 redesign. VA-75	15 Feb 1950
VA-76	Est. as VA-76	01 Jun 1955
	VA-76 disest.	30 Sep 1969
VA-81	(See VFA-81)	
VA-82	(See VFA-82)	

**Attack Squadrons (VA)—Continued**

<i>Squadron Designation</i>	<i>Lineage</i>	<i>Action Date</i>
VA-83	(See VFA-83)	
VA-84	Est. as VA-84	15 Sep 1948
	VA-84 disest.	29 Nov 1949
(1st) VA-85	Est. as VA-85	15 Sep 1948
	VA-85 disest.	29 Nov 1949
(2nd) VA-85	Reserve sqd. VA-859 called to active duty	01 Feb 1951
	VA-859 redesign. VA-85	04 Feb 1953
	VA-85 disest.	30 Sep 1994
(1st) VA-86	Est. as VA-86	01 Jul 1955
	VA-86 redesign. VF-84 on the same day it was est. as VA-86	01 Jul 1955
	(See VF-84 history records)	
(2nd) VA-86	(See VFA-86)	
VA-87	(See VFA-87)	
VA-93	Est. as VF-93	26 Mar 1952
	VF-93 redesign. VA-93	15 Sep 1956
	VA-93 disest.	31 Aug 1986
(1st) VA-94	Est. as VB-99	01 Jul 1943
	VB-99 redesign. VB-20	15 Oct 1943
	VB-20 redesign. VA-9A	15 Nov 1946
	VA-9A redesign. VA-94	12 Aug 1948
	VA-94 disest.(believe to be	30 Nov 1949)
(2nd) VA-94	(See VFA-94)	
(1st) VA-95	Est. as VT-20	15 Oct 1943
	VT-20 redesign. VA-10A	15 Nov 1946
	VA-10A redesign. VA-95	12 Aug 1948
	VA-95 disest.	30 Nov 1949
(2nd) VA-95	Est. as VA-95	26 Mar 1952
	VA-95 disest.	01 Apr 1970
(3rd) VA-95	Est. as VA-95	01 Apr 1972
VA-96	Est. as VA-96	30 Jun 1956
	VA-96 disest.	10 Apr 1958
VA-97	(See VFA-97)	
VA-104	Est. as VF-104	01 May 1952
	VF-104 redesign. VA-104	04 Dec 1953
	VA-104 disest.	31 Mar 1959
(1st) VA-105	Est. as VA-105	01 May 1952
	VA-105 disest.	01 Feb 1959
(2nd) VA-105	(See VFA-105)	
(1st) VA-106	Est. as VA-106	01 Jul 1955
	VA-106 redesign. VF-62 on the same day it was est. as VA-106	01 Jul 1955
	(See VF-62 history records)	
(2nd) VA-106	Est. as VBF 17	02 Jan 1945
	VBF 17 redesign. VF-6B	15 Nov 1946
	VF-6B redesign. VF-62	28 Jul 1948
	VF-62 redesign. VA-106	01 Jul 1955
	VA-106 disest.	07 Nov 1969
VA-112	Est. as VBF-11	09 Apr 1945
	VBF-11 redesign. VF-12A	15 Nov 1946
	VF-12A redesign. VF-112	15 Jul 1948
	VF-112 redesign. VA-112	15 Feb 1959
	VA-112 disest.	10 Oct 1969
VA-113	(See VFA-113)	
VA-114	Est. as VB-11	10 Oct 1942

**Attack Squadrons (VA)—Continued**

<i>Squadron Designation</i>	<i>Lineage</i>	<i>Action Date</i>
	VB-11 redesign. VA-11A	15 Nov 1946
	VA-11A redesign. VA-114	15 Jul 1948
	VA-114 disest.	01 Dec 1949
VA-115	Est. as VT-11	10 Oct 1942
	VT-11 redesign. VA-12A	15 Nov 1946
	VA-12A redesign. VA-115	15 Jul 1948
	VA-115 was in an inactive status from Aug 1967 to 1 Jan 1970 (it was not disestablished during this time frame and had a very limited number of personnel assigned to the squadron which was located at NAS Lemoore during the inactive period)	
	VA-115 reactivated	01 Jan 1970
VA-116	(See VA-144)	
VA-122	Est. as VC-35	25 May 1950
	VC-35 redesign. VA (AW)-35	01 Jul 1956
	VA(AW)-35 redesign. VA-122	29 Jun 1959
	VA-122 disest.	31 May 1991
(1st) VA-125	Called to active duty as VA-923	20 Jul 1950
	VA-923 redesign. VA-125	04 Feb 1953
	VA-125 disest.	10 Apr 1958
(2nd) VA-125	Est. as VA-26	30 Jun 1956
	VA-26 redesign. VA-125	11 Apr 1958
	VA-125 disest.	01 Oct 1977
VA-126	Est. as VA-126	06 Apr 1956
	VA-126 redesign. VF-126	15 Oct 1963
	(See VF-126 history records)	
VA-127	(See VFA-127)	
VA-128	Est. as VA-128	01 Sep 1967
VA-133	Est. as VA-133	21 Aug 1961
	VA-133 disest.	01 Oct 1962
(1st) VA-134	(See 2nd VA-174)	
(2nd) VA-134	Est. as VA-134	21 Aug 1961
	VA-134 disest.	01 Oct 1962
(1st) VA-135	Est. as VT-81	01 Mar 1944
	VT-81 redesign. VA-14A	15 Nov 1946
	VA-14A redesign. VA-135	02 Aug 1948
	VA-135 disest.	30 Nov 1949
(2nd) VA-135	Est. as VA-135	21 Aug 1961
	VA-135 disest.	01 Oct 1962
VA-144	Est. as VA-116	01 Dec 1955
	VA-116 redesign. VA-144	23 Feb 1959
	VA-144 disest.	29 Jan 1971
VA-145	Reserve sqd. VA-702 called to active duty	20 Jul 1950
	VA-702 redesign. VA-145	04 Feb 1953
	VA-145 disest.	01 Oct 1993
VA-146	(See VFA-146)	
VA-147	(See VFA-147)	
VA-151	(See VA-23)	
VA-152	Called to active duty as VF-713	01 Feb 1951
	VF-713 redesign. VF-152	04 Feb 1953

**Attack Squadrons (VA)—Continued**

<i>Squadron Designation</i>	<i>Lineage</i>	<i>Action Date</i>
	VF 152 redesign. VA-152	01 Aug 1958
	VA-152 disest.	29 Jan 1971
VA-153	Called to active duty as VF-831	01 Feb 1951
	VF-831 redesign. VF-153	04 Feb 1953
	VF-153 redesign. VA-153	17 Dec 1956
	VA-153 disest.	30 Sep 1977
VA-154	Est. as VB-153	26 Mar 1945
	VB-153 redesign. VA-15A	15 Nov 1946
	VA-15A redesign. VA-154	15 Jul 1948
	VA-154 disest.	01 Dec 1949
(1st) VA-155	Est. as VT-153	26 Mar 1945
	VT-153 redesign. VA-16A	15 Nov 1946
	VA-16A redesign. VA-155	15 Jul 1948
	VA-155 disest.	30 Nov 1949
(2nd) VA-155	Called to active duty as VA-728	01 Feb 1951
	VA-728 redesign. VA-155	04 Feb 1953
	VA-155 disest.	30 Sep 1977
(3rd) VA-155	Est. as VA-155	01 Sep 1987
	VA-155 disest.	30 Apr 1993
VA-156	Est. as VA-156	04 Jun 1956
	VA-156 redesign. VF-111	20 Jan 1959
	VF-111 redesign. VF-26	01 Sep 1964
	VF-26 redesign. VF-111	17 Sep 1964
	(See VF-111 history records)	
VA-163	Est. as VA-163	01 Sep 1960
	VA-163 disest.	01 Jul 1971
VA-164	Est. as VA-164	01 Sep 1960
	VA-164 disest.	02 Dec 1975
VA-165	Est. as VA-165	01 Sep 1960
VA-172	Est. as VBF-82	20 Aug 1945
	VBF-82 redesign. VF-18A	15 Nov 1946
	VF-18A redesign. VF-172	11 Aug 1948
	VF-172 redesign. VA-172	01 Nov 1955
	VA-172 disest.	15 Jan 1971
(1st) VA-174	Est. as VB-82	01 Apr 1944
	VB-82 redesign. VA-17A	15 Nov 1946
	VA-17A redesign. VA-174	11 Aug 1948
	VA-174 disest.	25 Jan 1950
(2nd) VA-174	Est. as VB-81	01 Mar 1944
	VB-81 redesign. VA-13A	15 Nov 1946
	VA-13A redesign. VA-134	02 Aug 1948
	VA-134 redesign. VF-174	15 Feb 1950
	VF-174 redesign. VA-174	01 Jul 1966
	VA-174 disest.	30 Jun 1988
VA-175	Est. as VT-82	01 Apr 1944
	VT-82 redesign. VA-18A	15 Nov 1946
	VA-18A redesign. VA-175	11 Aug 1948
	VA-175 disest.	15 Mar 1958
VA-176	Est. as VA-176	01 Jun 1955
	VA-176 disest.	01 Oct 1992
VA-185	Est. as VA-185	01 Dec 1986
	VA-185 disest.	30 Aug 1991
VA-192	(See VFA-192)	
VA-194	Est. as VB-19	15 Aug 1943
	VB-19 redesign. VA-19A	15 Nov 1946
	VA-19A redesign. VA-19A	24 Aug 1948

**Attack Squadrons (VA)—Continued**

<i>Squadron Designation</i>	<i>Lineage</i>	<i>Action Date</i>
	VA-194 disest.	01 Dec 1949
VA-195	(See VFA-195)	
VA-196	Est. as VF-153	15 Jul 1948
	VF-153 redesign. VF-194	15 Feb 1950
	VF-194 redesign. VA-196	04 May 1955
VA-203	(See VFA-203)	
VA-204	(See VFA-204)	
VA-205	Est as VA-205	01 Jul 1970
	VA-205 disest.	31 Dec 1994
VA-209	Est. as VA-209	01 Jul 1970
	VA-209 disest.	15 Aug 1971
VA-210	Est. as VA-210	01 Jul 1970
	VA-210 disest.	30 Jun 1971
VA-212	Est. as VF-212	20 Jun 1955
	VF-212 redesign. VA-212	01 Apr 1956
	VA-212 disest.	12 Dec 1975
VA-213	Est. as VA-213	15 Sep 1948
	VA-213 disest.(believed to be Jun 1949)	
(1st) VA-214	Est. as VA-214	15 Sep 1948
	VA-214 disest.	16 May 1949
(2nd) VA-214	Est. as VF-214	30 Mar 1955
	VF-214 redesign. VA-214	11 Oct 1956
	VA-214 disest.	01 Aug 1958
(1st) VA-215	Est. as VA-215	15 Jun 1955
	VA-215 disest.	31 Aug 1967
(2nd) VA-215	Est. as VA-215	01 Mar 1968
	VA-215 disest.	30 Sep 1977
VA-216	Est. as VA-216	28 Mar 1955
	VA-216 disest.	01 Aug 1970
VA-303	(See VFA-303)	
VA-304	Est. as VA-304	01 Jul 1970
	VA-304 disest.	31 Dec 1994
VA-305	(See VFA-305)	
VA-702	(See VA-145)	
VA-728	(See 2nd VA-155)	
VA-776	Reserve sqd. VA-776 activated	Feb 1968
	VA-776 returned to reserve status	01 Nov 1968
VA-831	Reserve sqd. VA-831 activated	Feb 1968
	VA-831 returned to reserve status	01 Nov 1968
VA-859	(See 2nd VA-85)	
VA-873	Reserve sqd. VA-873 activated	Feb 1968
	VA-873 returned to reserve status	01 Nov 1968
VA-923	(See 1st VA-125)	

**Attack Squadron (All Weather) (VA(AW))**

<i>Squadron Designation</i>	<i>Lineage</i>	<i>Action Date</i>
VA(AW)-33	Est. as VC-33	31 May 1949
	VC-33 redesign. VA(AW)-33	02 Jul 1956
	VA(AW)-33 redesign. VAW-33	30 Jan 1959
	VAW-33 redesign. VAQ-33	01 Feb 1968
	(See VAQ-33 history records)	
VA(AW)-35	(See VA-122)	

**Heavy Attack Squadrons (VAH)**

<i>Squadron Designation</i>	<i>Lineage</i>	<i>Action Date</i>
VAH-1	Est. as VAH-1	01 Nov 1955
	(Nucleus of VAH-1 formed from VP-3 which was disest.)	
	VAH-1 redesign. RVAH-1	01 Sep 1964
	RVAH-1 disest.	29 Jan 1979
	(See RVAH-1 history records)	
VAH-2	Est. as VAH-2	01 Nov 1955
	(Nucleus of VAH-2 formed from VP-29 which was disest.)	
	VAH-2 redesign. VAQ-132	01 Nov 1968
	(See VAQ-132 history records)	
VAH-3	Est. as VAH-3	15 Jun 1956
	(Nucleus of VAH-3 formed from VP-34 which was disest.)	
	VAH-3 redesign. RVAH-3	01 Jul 1964
	RVAH-3 disest.	17 Aug 1979
	(See RVAH-3 history records)	
VAH-4	Called to active duty as VP-931	02 Sep 1950
	VP-931 redesign. VP-57	04 Feb 1953
	VP-57 redesign. VAH-4	03 Jul 1956
	VAH-4 redesign. VAQ-131	01 Nov 1968
	(See VAQ-131 history records)	
VAH-5	Est. as VC-5	09 Sep 1948
	VC-5 redesign. VAH-5	01 Nov 1955
	VAH-5 redesign. RVAH-5	May 1956
	RVAH-5 disest.	30 Sep 1977
	(See RVAH-5 history records)	
VAH-6	Est. as VC-6	06 Jan 1950
	VC-6 redesign. VAH-6	01 Jul 1956
	VAH-6 redesign. RVAH-6	23 Sep 1965
	RVAH-6 disest.	20 Oct 1978
	(See RVAH-6 history records)	
VAH-7	Est. as VC-7	10 Aug 1950
	VC-7 redesign. VAH-7	01 Nov 1955
	VAH-7 redesign. RVAH-7	01 Dec 1964
	RVAH-7 disest.	28 Sep 1979
	(See RVAH-7 history records)	
VAH-8	Est. as VAH-8	01 May 1957
	VAH-8 disest.	17 Jan 1968
VAH-9	Est. as VC-9	15 Jan 1953
	VC-9 redesign. VAH-9	01 Nov 1955
	VAH-9 redesign. RVAH-9	03 Jun 1964
	RVAH-9 disest.	30 Sep 1977
	(See RVAH-9 history records)	
VAH-10	Est. as VAH-10	01 May 1961
	VAH-10 redesign. VAQ-129	01 Sep 1970
	(See VAQ-129 history records)	
VAH-11	Est. as VC-8	03 Dec 1951
	VC-8 redesign. VAH-11	01 Nov 1955
	VAH-11 redesign. RVAH-11	01 Jul 1966
	RVAH-11 disest.	01 Jun 1975
	(See RVAH-11 history records)	
VAH-13	Est. as VAH-13	03 Jan 1961
	VAH-13 redesign. RVAH-13	01 Nov 1964
	RVAH-13 disest.	30 Jun 1976

**Heavy Attack Squadrons (VAH)—Continued**

<i>Squadron Designation</i>	<i>Lineage</i>	<i>Action Date</i>
	(See RVAH-13 history records)	
VAH-15	Est. as VAH-15	15 Jan 1958
	VAH-15 disest.	15 Feb 1959
VAH-16	Est. as VAH-16	15 Jan 1958
	VAH-16 disest.	30 Jan 1959
VAH-21	Est. as VAH-21	01 Sep 1968
	VAH-21 disest.	16 Jun 1969
VAH-123	Est. as Heavy Attack Training Unit, Pacific	15 Jun 1957
	Redesig. VAH-123	29 Jun 1959
	VAH-123 disest.	01 Feb 1971

**Attack Mining Squadron (VA(HM))**

<i>Squadron Designation</i>	<i>Lineage</i>	<i>Action Date</i>
VA(HM)-10	To active duty as VP-772	01 Sep 1950
	VP-772 redesig. VP-17	04 Feb 1953
	VP-17 redesig. VA(HM)-10	01 Jul 1956
	VA(HM)-10 redesig. VP-17	01 Jul 1959
	(See VP-17 history records)	
VA(HM)-13	Est. as VB-104	10 Apr 1943
	VB-104 redesig. VPB-104	01 Oct 1944
	VPB-104 redesig. VP-104	15 May 1946
	VP-104 redesig. VP-HL-4	15 Nov 1946
	VP-HL-4 redesig. VP-24	01 Sep 1948
	VP-24 redesig. VA(HM)-13	01 Jul 1956
	VA(HM)-13 redesig. VP-24	01 Jul 1959
	(See VP-24 history records)	

**Tactical Aerial Refueling Squadron (VAK)**

<i>Squadron Designation</i>	<i>Lineage</i>	<i>Action Date</i>
VAK-208	Est. as VAQ-208	31 Jul 1970
	VAQ-208 redesig. VAK-208	01 Oct 1979
	VAK-208 disest.	30 Sep 1989
VAK-308	Est. as VAQ-308	02 May 1970
	VAQ-308 redesig. VAK-308	01 Oct 1979
	VAK-308 disest.	30 Sep 1988

**Light Attack Squadron (VAL)**

<i>Squadron Designation</i>	<i>Lineage</i>	<i>Action Date</i>
VAL-4	Est. as VAL-4	03 Jan 1969
	VAL-4 disest.	10 Apr 1972

**Heavy Photographic Squadron (VAP)**

<i>Squadron Designation</i>	<i>Lineage</i>	<i>Action Date</i>
VAP-61	Est. as VP-61	20 Jan 1951
	VP-61 redesig. VJ-61	05 Mar 1952
	VJ-61 redesig. VAP-61	Apr 1956
	VAP-61 redesig. VCP-61	01 Jul 1959
	VCP-61 redesig. VAP-61	01 Jul 1961
	VAP-61 disest.	01 Jul 1971

**Heavy Photographic Squadron (VAP)—Continued**

<i>Squadron Designation</i>	<i>Lineage</i>	<i>Action Date</i>
VAP-62	Est. as VJ-62	10 Apr 1952
	VJ-62 redesig. VAP-62	02 Jul 1956
	VAP-62 disest.	15 Oct 1969

**Strike Fighter Squadron (VFA)**

<i>Squadron Designation</i>	<i>Lineage</i>	<i>Action Date</i>
VFA-15	Est. as VA-67	01 Aug 1968
	VA-67 redesig. VA-15	02 Jun 1969
	VA-15 redesig. VFA-15	01 Oct 1986
VFA-22	Est. as VF-63	27 Jul 1948
	VF-63 redesig. VA-63	Mar 1956
	VA-63 redesig. VA-22	01 Jul 1959
	VA-22 redesig. VFA-22	04 May 1990
VFA-25	Est. as VT-17	01 Jan 1943
	VT-17 redesig. VA-6B	15 Nov 1946
	VA-6B redesig. VA-65	27 Jul 1948
	VA-65 redesig. VA-25	01 Jul 1959
	VA-25 redesig. VFA-25	01 Jul 1983
VFA-27	Est. as VA-27	01 Sep 1967
	VA-27 redesig. VFA-27	24 Jan 1991
VFA-37	Est. as VA-37	01 Jul 1967
	VA-37 redesig. VFA-37	28 Nov 1990
VFA-81	Est. as VA-66	01 Jul 1955
	VA-66 redesig. VF-81 on the same day it was est. as VA-66	01 Jul 1955
	VF-81 redesig. VA-81	01 Jul 1959
	VA-81 redesig. VFA-81	04 Feb 1988
VFA-82	Est. as VA-82.	01 May 1967
	VA-82 redesig. VFA-82	13 Jul 1987
VFA-83	Reserve sqd. VF-916 called to active duty	01 Feb 1951
	VF-916 redesig. VF-83	04 Feb 1953
	VF-83 redesig. VA-83	01 Jul 1955
	VA-83 redesig. VFA-83	03 Mar 1988
VFA-86	Reserve sqd. VF-921 called to active duty	01 Feb 1951
	VF-921 redesig. VF-84	04 Feb 1953
	VF-84 redesig. VA-86	01 Jul 1955
	VA-86 redesig. VFA-86	15 Jul 1987
VFA-87	Est. as VA-87	01 Feb 1968
	VA-87 redesig. VFA-87	01 May 1986
VFA-94	Est. as VF-94	26 Mar 1952
	VF-94 redesig. VA-94	01 Aug 1958
	VA-94 redesig. VFA-94	28 Jun 1990
VFA-97	Est. as VA-97	01 Jun 1967
	VA-97 redesig. VFA-97	24 Jan 1991
VFA-105	Est. as VA-105	04 Mar 1968
	VA-105 redesig. VFA-105	17 Dec 1990
VFA-106	Est. as VFA-106	27 Apr 1984
VFA-113	Est. as VF-113	15 Jul 1948
	VF-113 redesig. VA-113	Mar 1956
	VA-113 redesig. VFA-113	25 Mar 1983
VFA-125	Est. as VFA-125	13 Nov 1980
VFA-127	Est. as VA-127	15 Jun 1962
	VA-127 redesig. VFA-127	01 Mar 1987
VFA-131	Est. as VFA-131	03 Oct 1983

**Strike Fighter Squadron (VFA)**

<i>Squadron Designation</i>	<i>Lineage</i>	<i>Action Date</i>
VFA-132	Est. as VFA-132	03 Jan 1984
	VFA-132 disest.	01 Jun 1992
VFA-136	Est. as VFA-136	01 Jul 1985
VFA-137	Est. as VFA-137	01 Jul 1985
VFA-146	Est. as VA-146	01 Feb 1956
	VA-146 redesign. VFA-146	21 Jul 1989
VFA-147	Est. as VA-147	01 Feb 1967
	VA-147 redesign. VFA-147	20 Jul 1989
VFA-151	Est. as VF-23	06 Aug 1948
	VF-23 redesign. VF-151	23 Feb 1959
	VF-151 redesign. VFA-151	01 Jun 1986
VFA-161	Est. as VF-161	01 Sep 1960
	VF-161 redesign. VFA-161	01 Jun 1986
	VFA-161 disest.	01 Apr 1988
VFA-192	Est. as VF-153	26 Mar 1945
	VF-153 redesign. VF-15A	15 Nov 1946
	VF-15A redesign. VF-151	15 Jul 1948

**Strike Fighter Squadron (VFA)**

<i>Squadron Designation</i>	<i>Lineage</i>	<i>Action Date</i>
	VF-151 redesign. VF-192	15 Feb 1950
	VF 192 redesign. VA-192	15 Mar 1956
	VA-192 redesign. VFA-192	10 Jan 1986
VFA-195	Est. as VT-19	15 Aug 1943
	VT-19 redesign. VA-20A	15 Nov 1946
	VA-20A redesign. VA-195	24 Aug 1948
VFA-203	VA-195 redesign. VFA-195	15 Apr 1985
	Est. as VA-203	01 Jul 1970
	VA-203 redesign. VFA-203	01 Oct 1989
VFA-204	Est. as VA-204	01 Jul 1970
	VA-204 redesign. VFA-204	01 May 1991
VFA-303	Est as VA-303	01 Jul 1970
	VA-303 redesign. VFA-303	01 Jan 1984
	VFA-303 disest.	31 Dec 1994
VFA-305	Est. as VA-305	01 Jul 1970
	VA-305 redesign. VFA-305	01 Jan 1987
	VFA-305 disest.	31 Dec 1994



## APPENDIX 7

# Types of Aircraft Listed in the Squadron Histories

**T**HE FOLLOWING TYPES OF AIRCRAFT are listed in the Aircraft Assignment section of the squadron histories covered in this book.

<i>Aircraft Designation</i>	<i>Popular Name</i>	<i>Manufacturer</i>
A-1E (see AD-5)	Skyraider	Douglas
A-1H (see AD-6)	Skyraider	Douglas
A-1J (see AD-7)	Skyraider	Douglas
A-3A (see A3D-1)	Skywarrior	Douglas
A-3B (see A3D-2)	Skywarrior	Douglas
A-4B (see A4D-2)	Skyhawk	Douglas
A-4C (see A4D-2N)	Skyhawk	Douglas
A-4E	Skyhawk	Douglas
A-4F	Skyhawk	Douglas
A-4L	Skyhawk	Douglas
A-5 (see A3J)	Vigilante	North American
A-6A	Intruder	Grumman
A-6B	Intruder	Grumman
A-6C	Intruder	Grumman
A-6E	Intruder	Grumman
A-7A	Corsair II	Vought
A-7B	Corsair II	Vought
A-7C	Corsair II	Vought
A-7E	Corsair II	Vought
AD-1	Skyraider	Douglas
AD-1Q	Skyraider	Douglas
AD-2	Skyraider	Douglas
AD-2Q	Skyraider	Douglas
AD-3	Skyraider	Douglas
AD-3N	Skyraider	Douglas
AD-3Q	Skyraider	Douglas
AD-4	Skyraider	Douglas
AD-4B	Skyraider	Douglas
AD-4L	Skyraider	Douglas
AD-4N	Skyraider	Douglas
AD-4NA	Skyraider	Douglas
AD-4NL	Skyraider	Douglas
AD-4Q	Skyraider	Douglas
AD-5 (Redesignated A-1E)	Skyraider	Douglas
AD-5N	Skyraider	Douglas
AD-5Q	Skyraider	Douglas
AD-6 (Redesignated A-1H)	Skyraider	Douglas
AD-7 (Redesignated A-1J)	Skyraider	Douglas
AF	Guardian	Grumman
AJ-2	Savage	North American
AJ-2P	Savage	North American
AM-1	Mauler	Martin
AP-2H	Neptune	Lockheed
A3D-1 (Redesignated A-3A)	Skywarrior	Douglas
A3D-1P	Skywarrior	Douglas

<i>Aircraft Designation</i>	<i>Popular Name</i>	<i>Manufacturer</i>
A3D-1Q	Skywarrior	Douglas
A3D-2 (Redesignated A-3B)	Skywarrior	Douglas
A3D-2P (Redesignated RA-3B)	Skywarrior	Douglas
A3D-2Q	Skywarrior	Douglas
A3D-2T (Redesignated TA-3B)	Skywarrior	Douglas
A3J (Redesignated A-5)	Vigilante	North American
A4D-1	Skyhawk	Douglas
A4D-2 (Redesignated A-4B)	Skyhawk	Douglas
A4D-2N (Redesignated A-4C)	Skyhawk	Douglas
BG-1		Great Lakes
BM-1		Martin
BM-2		Martin
BT-1		Northrop
CS-1		Curtiss
DT-2		Douglas/NAF/ LWF/Dayton-Wright
F-3B (see F3H-2)	Demon	McDonnell
F-4B	Phantom II	McDonnell
F-4J	Phantom II	McDonnell
F-4N	Phantom II	McDonnell
F-4S	Phantom II	McDonnell
F-5E	Tiger II	Northrop
F-5F	Tiger II	Northrop
F-8A (see F8U-1)	Crusader	Vought
F-8B (see F8U-1E)	Crusader	Vought
F-8C (see F8U-2)	Crusader	Vought
F-8D (see F8U-2N)	Crusader	Vought
F-8E (see F8U-NE)	Crusader	Vought
F/A-18	Hornet	McDonnell-Douglas
F/A-18A	Hornet	McDonnell-Douglas
F/A-18B	Hornet	McDonnell-Douglas
F/A-18C	Hornet	McDonnell-Douglas
F/A-18D	Hornet	McDonnell-Douglas
FG-1	Corsair	Goodyear
FG-1D	Corsair	Goodyear
FH-1	Phantom	McDonnell
FJ-3	Fury	North American
FJ-3M	Fury	North American
FJ-4	Fury	North American
FJ-4B	Fury	North American
FM-2	Wildcat	General Motors
F2H-1	Banshee	McDonnell
F2H-2	Banshee	McDonnell
F2H-2B	Banshee	McDonnell
F2H-3	Banshee	McDonnell
F2H-4	Banshee	McDonnell
F3D-2	Skyknight	Douglas
F3H-2 (Redesignated F-3B)	Demon	McDonnell
F3H-2M	Demon	McDonnell
F4D-1	Skyray	Douglas
F4U	Corsair	Vought
F4U-1	Corsair	Vought



<i>Aircraft Designation</i>	<i>Popular Name</i>	<i>Manufacturer</i>	<i>Aircraft Designation</i>	<i>Popular Name</i>	<i>Manufacturer</i>
F4U-1D	Corsair	Vought	SB2A	Buccaneer	Brewster
F4U-4	Corsair	Vought	SB2C-1	Helldiver	Curtiss
F4U-4B	Corsair	Vought	SB2C-1C	Helldiver	Curtiss
F4U-5	Corsair	Vought	SB2C-3	Helldiver	Curtiss
F6F	Hellcat	Grumman	SB2C-4	Helldiver	Curtiss
F6F-3	Hellcat	Grumman	SB2C-4E	Helldiver	Curtiss
F6F-5	Hellcat	Grumman	SB2C-5	Helldiver	Curtiss
F6F-5N	Hellcat	Grumman	SB2U-1	Vindicator	Vought/Sikorsky
F6F-5P	Hellcat	Grumman	SB2U-2	Vindicator	Vought/Sikorsky
F7F-4N	Tigercat	Grumman	SC-1		Martin
F7U-3	Cutlass	Vought	SC-2		Martin
F7U-3M	Cutlass	Vought	S2F-1	Tracker	Grumman
F8F	Bearcat	Grumman	T-28B	Trojan	North American
F8F-1	Bearcat	Grumman	T-28C	Trojan	North American
F8F-1B	Bearcat	Grumman	T-34C	Mentor	Beech
F8F-2	Bearcat	Grumman	T-38B	Talon	Northrop
F8U-1 (Redesignated F-8A)	Crusader	Vought	T-39D	Sabreliner	North American
F8U-1E (Redesignated F-8B)	Crusader	Vought	TA-3B (see A3D-2T)	Skywarrior	Douglas
F8U-1P (Redesignated RF-8A)	Crusader	Vought	TA-4B	Skyhawk	Douglas
F8U-2 (Redesignated F-8C)	Crusader	Vought	TA-4F	Skyhawk	Douglas
F8U-2N (Redesignated F-8D)	Crusader	Vought	TA-4J	Skyhawk	Douglas
F8U-2NE (Redesignated F-8E)	Crusader	Vought	TA-7C	Corsair II	Vought
F9F-2	Panther	Grumman	TB-1		Boeing
F9F-2B	Panther	Grumman	TBD-1	Devastator	Douglas
F9F-3	Panther	Grumman	TBF-1	Avenger	Grumman
F9F-5	Panther	Grumman	TBF-1C	Avenger	Grumman
F9F-6	Cougar	Grumman	TBF-1P	Avenger	Grumman
F9F-8	Cougar	Grumman	TBM-1	Avenger	General Motors
F9F-8B	Cougar	Grumman	TBM-1C	Avenger	General Motors
F9F-8T (Redesignated TF-9J)	Cougar	Grumman	TBM-1D	Avenger	General Motors
KA-3B	Skywarrior	Douglas	TBM-3	Avenger	General Motors
KA-6D	Intruder	Grumman	TBM-3E	Avenger	General Motors
O-2A		Cessna	TBM-3J	Avenger	General Motors
OV-10A	Bronco	North American	TBM-3N	Avenger	General Motors
PB4Y-1P (Redesignated P4Y-1P)	Liberator	Consolidated	TBM-3Q	Avenger	General Motors
P2V-3B	Neptune	Lockheed	TBM-3S	Avenger	General Motors
P4Y-1P (see PB4Y-1P)	Liberator	Consolidated	TBM-3W	Avenger	General Motors
QT-38A	Talon	Northrop	TBY	Seawolf	Vought/Consolidated
RA-3B (see A3D-2P)	Skywarrior	Douglas	TC-4C	Academe or	Grumman
RF-8A (see F8U-1P)	Crusader	Vought		Gulfstream	
SBC-4	Helldiver	Curtiss	TF-1Q	Trader	Grumman
SBD-3	Dauntless	Douglas	TF-9J (see F9F-8T)	Cougar	Grumman
SBD-3P	Dauntless	Douglas	TF/A-18A	Hornet	McDonnell-Douglas
SBD-4	Dauntless	Douglas	TG-1		Great Lakes
SBD-5	Dauntless	Douglas	TG-2		Great Lakes
SBD-6	Dauntless	Douglas	TV-2	Shooting Star	Lockheed
SBF-4E	Helldiver	Canadian Fairchild	T2D-1		Douglas
SBW-3	Helldiver	Canadian Car and Foundry	T3M-2		Martin
			T4M-1		Martin
SBW-4E	Helldiver	Canadian Car and Foundry	XBT2D-1 (see AD or A-1)	Dauntless II	Douglas
			YOV-10D	Bronco	North American
SBW-5	Helldiver	Canadian Car and Foundry			

# ***Glossary of Abbreviations and Terms***

---

AMRAAM	Advanced Medium Range Air-to-Air Missile
ACV	Designation for Escort Carriers or Auxiliary Aircraft Carrier
ADM	Admiral
AFEM	Armed Forces Expeditionary Medal
AG	Air Group
AGMR	Major Communications Relay Ship
AirDet	Air Detachment
AKV	Aircraft Ferry, later Cargo Ship and Aircraft Ferry
a.p.	Armor piercing
ARM	Antiradiation Missile
ASW	Antisubmarine Warfare
ATG	Air Task Group
AVG	Designation for Escort Carriers
AVT	Designation for Training Aircraft Carrier
BuAer	Bureau of Aeronautics
CAINS	Carrier Aircraft Inertial Navigation System
CAP	Combat Air Patrol
CAPT	Captain
Carib	Caribbean Sea
CDR	Commander
C.O.	Commanding Officer
COD	Carrier on board delivery
COMFAIR	Commander Fleet Air
COMHATWING	Commander Heavy Attack Wing
COMLATWING	Commander Light Attack Wing
COMMATWING	Commander Medium Attack Wing
COMOPDEVFOR	Commander Operational Development Force United States Fleet
COMSTRKFIGHTWING	Commander Strike Fighter Wing
CONUS	Continental United States
CNO	Chief of Naval Operations
CV	Designation for Aircraft Carrier
CVA	Designation for Attack Aircraft Carrier
CVAG	Attack Carrier Air Groups
CVAN	Designation for Attack Aircraft Carrier, Nuclear-powered
CVB	Designation for Aircraft Carrier, Large
CVBG	Battle Carrier Air Groups
CVE	Designation for Aircraft Carrier, Escort
CVEG	Escort Carrier Air Groups
CVG	Carrier Air Group
CVG(N)	Night Carrier Air Groups
CVHA	Assault Helicopter Aircraft Carrier
CVHE	Escort Helicopter Aircraft Carrier
CVL	Designation for Aircraft Carrier, Small
CVLG	Light Carrier Air Groups
CVN	Designation for Aircraft Carrier, Nuclear
CVS	Designation for Antisubmarine Support Aircraft Carrier
CVSG	Antisubmarine Carrier Air Groups
CVT	Designation for Training Aircraft Carrier
CVW	Carrier Air Wing
CVU	Designation for Utility Aircraft Carrier

---

Disest.	Disestablished
DMZ	Demilitarized Zone
ECM	Electronic Countermeasures
Enter	Enterprise (CV 6)
Enter AG	Enterprise Air Group
Est.	Established
FEWSG	Fleet Electronic Warfare Support Group
FMS	Foreign Military Sales
ft	Feet
FY	Fiscal Year
g.p.	General purpose
HARM	High speed antiradiation missile
hp	horsepower
HSM	Humanitarian Service Medal
HVAR	High Velocity Aircraft Rocket
IFF	Identification Friend or Foe
in	inch
IO	Indian Ocean
JATO	Jet Assisted Takeoff
JMUA	Joint Meritorious Unit Award
KIA	Killed in action
KLM	Kuwait Liberation Medal
KPUC	Korean Presidential Unit Citation
KSM	Korean Service Medal
Lant	Atlantic
lbs	Pounds
LCDR	Lieutenant Commander
Lex	Lexington (CV 2)
Lex AG	Lexington Air Group
LPH	Amphibious Assault Ship
LSO	Landing Signal Officer
LT	Lieutenant
LT (jg)	Lieutenant Junior Grade
MAD	Magnetic Airborne (or Anomaly) Detection
MAG	Marine Air Group
MAW	Marine Air Wing
MCAS	Marine Corps Air Station
Med	Mediterranean Sea
MIA	Missing in action
MiG	Russian designated aircraft designed by Artem I. Mikoyan and Mikhail I. Gurevich
MUC	Meritorious Unit Commendation
NAAF	Naval Air Auxiliary Facility
NAAS	Naval Air Auxiliary Station
NAF	Naval Air Facility
NALCOLANTUNIT	Naval Air Logistics Controll Office, Atlantic Unit
NAS	Naval Air Station
NATO	North Atlantic Treaty Organization
NAVE	Navy Battle E Ribbon
NDSM	National Defense Service Medal
NEM	Navy Expeditionary Medal
NFO	Naval Flight Officer

---

nm	Nautical mile
NorLant	Northern Atlantic Ocean
NorPac	Northern Pacific
NS	Naval Station
NUC	Navy Unit Commendation
NVG	Night Vision Goggle
Ops	Operations
ORI	Operational Readiness Inspection
Pac	Pacific
POL	Petroleum, oil, lubricants
POW	Prisoner of war
PUC	Presidential Unit Citation
RADM	Rear Admiral
RCVG	Replacement Air Group (later Combat Readiness Air Group)
RCVW	Combat Readiness Air Wing
Redesig.	Redesignated
RIO	Radar Intercept Officer
RN	Royal Navy
RVAH	Reconnaissance Attack Squadron
RVNGC	Republic of Vietnam Meritorious Unit Citation (Gallantry Cross Medal Color with Palm)
SAM	Surface to air missile
SAR	Search and rescue
Sara	Saratoga (CV 3)
Sara AG	Saratoga Air Group
SASM	Southwest Asia Service Medal
SEALS	Sea-air-land team
SoLant	Southern Atlantic Ocean
SoPac	South Pacific
sq	Square
TACAN	Tactical Air Navigation (system)
t.o.	Takeoff
TWA	Trans World Airlines
UNSM	United Nations Service Medal
USAT	U.S. Army Transport
USMC	United States Marine Corps
USN	United States Navy
USNS	United States Naval Ship
VA	Attack Squadron
VA(AW)	All-Weather Attack Squadron
VADM	Vice Admiral
VAH	Heavy Attack Squadron
VA(HM)	Attack Mining Squadron
VAK	Tactical Aerial Refueling Squadron
VAL	Light Attack Squadron
VAP	Heavy Photographic Squadron
VAQ	Carrier Tactical Electronics Warfare Squadron
VAW	All-Weather Airborne Early Warning Squadron or Carrier Airborne Early Warning Squadron
VB	Bombing Squadron
VBF	Bomber-Fighter Squadron
VC	Composite Squadron

VCP	Photographic Reconnaissance Squadron Composite
VGS	Escort Scouting Squadron
VF	Fighting Plane Squadron or Fighter Squadron
VFA	Fighter Attack Squadron or Strike Fighter Squadron
VJ	Reconnaissance Squadron or Photographic Squadron
VNSM	Vietnam Service Medal
VP	Patrol Squadron
VS	Scouting Squadron or Carrier Antisubmarine Squadron
VSF	Antisubmarine Fighter Squadron
VT	Torpedo Squadron
VX	Aircraft Development Squadron
WestPac	Western Pacific Ocean
York	Yorktown (CV 5)
York AG	Yorktown Air Group
1st	First
2nd	Second

# Bibliography

## Primary Source

### Manuscripts/Collections

National Archives, Military Reference Branch,  
Washington, DC.

Ship's Deck Logs, 1946–1961.

### Naval Historical Center

Aviation History Branch, Washington, DC.

Aircraft File, 1911-

Air Station Binder File, 1920s–1950s.

Aviation Carrier and Unit History Card File, 1942–  
1952.

Aviation Insignia File, disest., circa 1930s–

Aviation Insignia File, active, circa 1930s–

Aviation Unit Command History and Misc. File,  
1957-

Awards File, 1940s- (not complete).

Biographical Files, circa 1930s-

Model Designation of Naval Airplane Files, 1926–  
1962.

Naval Air Reserve File, 1940s- (not complete).

Personnel Award Cards, microfilm, 1942–1970s.

Vietnam Subject File, 1964–1975.

Visual Identification System (Tail Codes) File,  
1946–

Navy Department Library, Washington, DC.

Annual Report of the Chief of Naval Operations to  
the Secretary of the Navy. In the Collection of  
the Secretary of the Navy's Annual Report, 1916–

Cruise Book Collection, 1940s-

Operational Archives Branch, Washington, DC.

Action Reports, World War II.

Action Reports, Post-1 Jan 1946.

Aviation History Collection, 1942–1952.

Biographical Collection, circa 1930s–1972.

Command Files, Post-1 Jan 1946.

Command Files, Post-1 Jan 1974.

War Diaries, World War II.

Ships' History Branch, Washington, DC.

Personnel Award Cards, 1942–1970s.

Ships' Deck Logs, 1962–

Ships' Command History and Misc. Files, 1950s–

VA: Center for Naval Analyses, CRC 322, prepared for  
Office of Naval Research and Office of the  
Chief of Naval Operations, July 1977.

Ross, R. A. *Air Defense During the Mining of Haiphong  
Harbor on 9 May 1972*. Arlington, VA: OEG  
Center for Naval Analyses (CNA)00449–73,  
November 1973.

Siegel, Adam B. *U.S. Navy Crisis Response Activity,  
1946-1989: Preliminary Report*. Alexandria, VA:  
Center for Naval Analyses, CRM 89–315,  
November 1989.

U.S. Department of Navy. Bureau of Aeronautics.  
Aviation Circular Letters, 1944–1952. Naval  
Historical Center, Aviation History Branch.

\_\_\_\_\_. *Monthly Status of Naval Aircraft*. Wash-  
ington, 1926–1954.

This document was originally called  
*Status of Aircraft* and then changed to  
*Monthly Status of Naval Aircraft*. In 1944  
control of the document changed from  
Bureau of Aeronautics to Office of Chief of  
Naval Operations.

\_\_\_\_\_. Bureau of Personnel. *The U.S. Navy and Marine  
Corps Awards Manual (NavPers 15, 790 Revised  
1953)*. Washington, 1953.

\_\_\_\_\_. Chief of Naval Operations. Aircraft Inventory  
Reporting System (AIRS), Naval Aircraft Listing by  
Unit (INV-16). Washington, 1989–

\_\_\_\_\_. Aircraft Inventory Reporting System  
(AIRS), Naval Aircraft Listing by Command  
(INV-15). Washington, 1989–

\_\_\_\_\_. Aircraft Inventory Reporting System  
(AIRS), Naval Aircraft Listing by TMS (Aircraft  
Type)(INV-14). Washington, 1989–

\_\_\_\_\_. *Allowances and Location of Naval (Navy)  
Aircraft*. Washington, 1946–1988.

The forerunner to this document was  
originally issued by two separate offices  
within the Chief of Naval Operations under  
different titles. In 1946 the Deputy Chief of  
Naval Operations (Operations) issued the  
*Location of United States Naval, Marine and  
Coast Guard Aircraft* and the Deputy Chief  
of Naval Operations (Air) issued *Aircraft  
Complements and Allowances of the Navy  
and Marine Corps*. In 1948 the Aircraft  
Statistics Branch of the Deputy Chief of

### Unpublished Sources

Mahoney, Robert B. *U.S. Navy Responses to Inter-  
national Incidents and Crisis, 1955–1975, Volume  
1: Survey of Navy Crisis Operations and Volume 2:  
Summaries of Incidents and Responses*. Arlington,

Naval Operations (Air) issued a document titled *Location of Naval Aircraft*. Sometime in 1949 the publication *Aircraft Complements and Allowances of the Navy and Marine Corps* was discontinued. In January 1950 the publications *Location of United States Naval, Marine and Coast Guard Aircraft* and *Location of Naval Aircraft* were consolidated and formed the publication *Location of Navy Aircraft*. In September 1951 the publication *Location of Navy Aircraft* was replaced by the *Allowances and Location of Navy Aircraft* (OPNAV NOTICE 3110). This title was changed to *Allowances and Location of Naval Aircraft* (OPNAV NOTICE 3110) in 1969. In 1988 the *Allowances and Location of Naval Aircraft* (OPNAV NOTICE 3110) was discontinued.

\_\_\_\_\_. DCNO (Air Warfare) OEG/OP-508W. *Summary of Air Operations in Southeast Asia 1 January 1972–31 January 1973*. Arlington, VA: Center for Naval Analyses (CNA)001448–73, January 1974.

\_\_\_\_\_. DCNO (Air Warfare) OEG/OP-05W. *Summary of Air Operations in Southeast Asia May 1972*. Arlington, VA: Center for Naval Analyses (CNA)001368–72, September 1972.

\_\_\_\_\_. Letter from the Office of Chief of Naval Operations, Op–33M6 Serial: 1739P33 dated 1 October 1946, Subject: Naval and Marine Fleet Aviation Unit Designations, History of. Washington, June 1941–September 1946.

\_\_\_\_\_. Letter from the Office of Chief of Naval Operations, Serial: 4184P33 dated 15 December 1947, Subject: Naval and Marine Fleet Aviation Unit Designations, History of. Washington, June 1941–15 December 1947.

\_\_\_\_\_. Letter from the Office of Chief of Naval Operations, Op–331B/jfs, A12–1, Serial: 1694P33 dated 15 December 1948, Subject: Naval and Marine Fleet Aviation Unit Designations, History of. Washington, June 1941–December 1948.

\_\_\_\_\_. *Naval Aeronautic Organization*. Washington, 1922–

In 1951 OPNAV Notice 0530 was attached to the title of the *Naval Aeronautic Organization* and in 1953 the OPNAV Notice number was changed to 5400. Thereafter, the *Naval Aeronautical Organization* has been issued under OPNAV Notice 5400.

\_\_\_\_\_. Unit Awards Office. Unit Awards and Campaign Participation (computer listing). Washington, 1987.

\_\_\_\_\_. *U.S. Navy and Marine Corps Awards Manual*. Washington: SECNAVINST. 1650.1C, 9 November 1966.

\_\_\_\_\_. *USS Saratoga (CV 3). Plane Talk of USS Saratoga (CV 3), Flights I–XV, Feb 1928–Jun 1942*. Naval Historical Center, Aviation History Branch.

\_\_\_\_\_. *U.S. Naval Administrative Histories of World War II*, Office of the Deputy Chief of Naval Operations (Air), “Air Task Organization in the Atlantic Ocean Area.” Washington. 1945.

\_\_\_\_\_. “Air Task Organization in the Pacific Ocean Areas: Task Organization of Ship-Based Aircraft.” Washington. n.d.

\_\_\_\_\_. “Aviation in the Fleet Exercises, 1911–1939.” Vol. XVI. Washington. n.d.

\_\_\_\_\_. “History of Naval Aviation (1898–1917).” Vol. III, Part 1. Washington. 1946.

### Secondary Sources

#### Books

Cressman, Robert. *That Gallant Ship USS Yorktown (CV-5)*. Missoula, MT: Pictorial Histories Publishing Co., 1985.

Francillon, Rene J. *Tonkin Gulf Yacht Club U.S. Carrier Operations Off Vietnam*. Annapolis: Naval Institute Press, 1988.

\_\_\_\_\_. *Japanese Aircraft of the Pacific War*. London: Putnam and Co., 1970.

Morison, Samuel Eliot. *History of United States Naval Operations in World War II*. Boston: Little, Brown and Company, 1947–1962. 15 vols.

Marolda, Edward J., and Oscar P. Fitzgerald. *The United States Navy and the Vietnam Conflict, Volume II, From Military Assistance to Combat 1959–1965*. Naval Historical Center, Department of the Navy, Washington, 1986.

Marolda, Edward J., and G. Wesley Pryce III. *A Short History of the United States Navy and the Southeast Asian Conflict 1950–1975*. Naval Historical Center, Department of the Navy, Washington, 1984.

Naval Historical Center. *Dictionary of American Naval Fighting Ships*. Washington: Naval Historical Center/GPO, 1959–1991. 9 vols.

\_\_\_\_\_. *United States Naval Chronology, World War II*. Washington: GPO, 1955.

Olynyk, Frank J. *USN Credits for the Destruction of Enemy Aircraft in Air-to-Air Combat World War II, Victory List No. 2*. Aurora, OH: Frank J. Olynyk publisher, 1982.

Reynolds, Clark G. *The Fighting Lady, The New Yorktown in the Pacific War*. Missoula, MT: Pictorial Histories Publishing Co., 1986.

Stafford, Edward P. *The Big E: the Story of the USS Enterprise*. New York: Random House, 1962.

Swanborough, Gordon and Peter M. Bowers. *United States Navy Aircraft Since 1911*. Annapolis, MD: Naval Institute Press, 1968, 1976 and 1990.

U.S. Naval Academy Alumni Association. *Register of Alumni, Graduates and Former Naval Cadets and Midshipmen*. Annapolis: The Association, 1986–

- U.S. Navy Department. Bureau of Aeronautics. "Annual Report of the Chief of the Bureau of Aeronautics for the Fiscal Year 1922." Washington, GPO, 1922.
- \_\_\_\_\_. Technical Note 213 and 235, "Type, Class and Model Designation of Airplanes." Washington, GPO, March 29, 1922 and March 10, 1923.
- \_\_\_\_\_. Bureau of Navigation. *Navy Directory; Officers of the United States Navy and Marine Corps*. Washington: GPO, 1908–1942.
- \_\_\_\_\_. Bureau of Personnel. *Decorations, Medals, Ribbons, and Badges of the United States Navy, Marine Corps and Coast Guard, 1861-1948*. Washington, GPO, 1948.
- \_\_\_\_\_. *Register of Commissioned and Warrant Officers of the United States Naval Reserve*. Washington: GPO, 1921-
- \_\_\_\_\_. *Register of Commissioned and Warrant Officers of the United States Navy and Marine Corps and Reserve Officers on Active Duty*. Washington: Various publishers, 1798–
- \_\_\_\_\_. *General Orders*. Washington: GPO, 1920s–1930s.
- \_\_\_\_\_. Office of Naval Operations. *United States Naval Aviation 1910–1980*. 3r ed. Prepared at the Direction of the Deputy Chief of Naval Operations (Air Warfare) and the Commander, Naval Air Systems Command. Washington: GPO, 1981.
- \_\_\_\_\_. Office of Public Information. *Navy Cross:*

*Officers and Enlisted Men of the United States Navy Awarded the Navy Cross. December 7, 1941–July 1, 1945*. Washington, 1945.

#### Periodicals

- All Hands*. (U.S. Bureau of Naval Personnel). Washington, August 1922–
- American Aviation Historical Society Journal*. Redondo Beach, CA, Vol. 1, Spring 1956–
- Approach*; The Naval Aviation Safety Review. (U.S. Naval Safety Center). Norfolk, VA, Vol. 1, July 1955–
- Foundation*. (Naval Aviation Museum Foundation, Inc.). Pensacola, FL, Vol. 1 No. 1, May 1980–
- The Hook, Journal of Carrier Aviation*. San Diego, CA, Vol. 1 No. 1, 1973–
- The National Geographic Magazine*. (National Geographic Society). Washington, Vol. 83 No. 6, June 1943.
- National Geographic Society. *Insignia and Decorations of the U.S. Armed Forces*, by Gilbert Grosvenor and others. Washington, Revised Edition, December 1, 1944.
- Naval Aviation News*. (U.S. Office of Naval Operations). Washington, December 1917–
- Navy Times*. Washington, Vol. 1, October 20, 1951–
- Surface Warfare*. (U.S. Office of Chief of Naval Operations). Washington, 1975–
- United States Naval Institute Proceedings*. Annapolis, MD, Vol. 1, 1874–





# ***Index of Squadron Histories and Aircraft Data***

---

## ***Squadron Histories***

	<i>Page</i>		<i>Page</i>
VA-1E	17	Second VA-106	169
VA-1L	18	VA-112	174
VA-12	20	VA-114	178
VA-15	25	VA-115	181
VA-16	30	VA-122	189
VA-21A	31	VA-125	194
VA-22A	32	Second VA-125	196
VA-23	33	VA-128	199
Second VA-34	37	VA-133	201
Third VA-34	41	Second VA-134	202
VA-35	44	VA-135	203
Second VA-35	50	Second VA-135	205
VA-36	59	VA-144	206
Second VA-36	62	VA-145	209
VA-38	64	VA-152	214
VA-42	65	VA-153	218
VA-44	70	VA-154	222
Second VA-44	72	VA-155	224
VA-45	75	Second VA-155	226
Second VA-45	77	Third VA-155	231
VA-46	79	VA-163	233
VA-52	83	VA-164	235
VA-54	89	VA-165	238
Second VA-54	96	VA-172	242
VA-55	100	VA-174	246
Second VA-55	106	Second VA-174	248
VA-56	108	VA-175	252
Second VA-64	113	VA-176	255
Second VA-65	115	VA-185	259
Second VA-66	120	VA-194	261
VA-72	124	VA-196	264
VA-75	129	VA-205	269
Second VA-75	132	VA-209	271
VA-76	138	VA-210	272
VA-84	142	VA-212	273
VA-85	144	VA-213	277
Second VA-85	145	VA-214	278
VA-93	150	Second VA-214	279
VA-94	155	VA-215	281
VA-95	157	Second VA-215	283
Second VA-95	159	VA-216	285
Third VA-95	162	VA-304	289
VA-96	164	VA-776	291
VA-104	165	VA-831	292
VA-105	167	VA-873	293

**Squadron Histories—Continued**

	<i>Page</i>
VAH-8	295
VAH-15	298
VAH-16	299
VAH-21	300
VAH-123	301
VAK-208	303
VAK-308	305
VAL-4	307
VAP-61	309
VAP-62	314
VFA-15	317
VFA-22	320
VFA-25	328
VFA-27	335
VFA-37	338
VFA-81	341
VFA-82	345
VFA-83	348
VFA-86	352
VFA-87	358
VFA-94	361
VFA-97	367
VFA-105	370
VFA-106	373
VFA-113	375
VFA-125	381
VFA-127	383
VFA-131	387
VFA-132	389
VFA-136	391
VFA-137	393
VFA-146	395
VFA-147	400
VFA-151	404
VFA-161	412
VFA-192	418
VFA-195	426
VFA-203	434
VFA-204	436
VFA-303	438
VFA-305	440

**Aircraft Data**

	<i>Page</i>
A-3 (A3D) Skywarrior	443
A4D (A-4) Skyhawk	446
A3J (A-5) Vigilante	448
A-6 Intruder	449
A-7 Corsair II	451
AD (A-1) Skyraider	453
AF Guardian	456
AJ (A-2) Savage	458
AM Mauler	459
BG	461
BM	462
BT	463
CS and SC	464
DT-2	465
F-4 Phantom II	466
F-5 (T-38) Talon	468
F2H (F-2) Banshee	469
F3D (F-10) Skyknight	470
F3H (F-3) Demon	471
F4D (F-6) Skyray	473
F4U/FG/F3A Corsair	474
F6F Hellcat	477
F7F Tigercat	479
F7U Cutlass	481
F8F Bearcat	482
F8U (F-8) Crusader	483
F9F (F-9) Panther and Cougar	485
F/A-18 Hornet	489
FH (FD) Phantom	492
FJ-3/4 (F-1) Fury	493
FM Wildcat	494
OV-10 Bronco	495
PB4Y Liberator	496
SB2A Buccaneer	498
SB2C/SBW/SBF Helldiver	499
SB2U Vindicator	501
SBC	502
SBD Dauntless	503
T3J (T-39) Sabreliner	505
T2D/P2D	506
T3M	507
T4M and TG and TE	508
TB	510
TBD Devastator	511
TBF/TBM Avenger	512
TBY Seawolf	515
TC-4C Academe	516

**Welcome**  
to the **CD-ROM** edition  
of the



**Dictionary of American  
Naval Aviation Squadrons**

**Volume 1**

Page down to continue



***Please note . . .***

***There were no known differences  
between the material on this  
CD-ROM and the printed book—  
Dictionary of American Naval  
Aviation Squadrons***

Page down to continue

# ***How to use the CD-ROM***

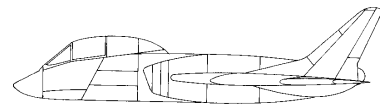

**Clicking on a title will take you to that document.**



**Clicking on a topic will take you to more information on that topic.**

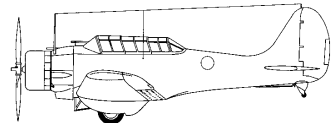

**Clicking on the toolbar direction symbols will move forward or backward through a document.**

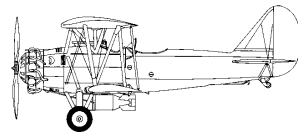

**Using the Page-Up and Page-Down keys will move you one page at a time.**

# Contents

**Foreword**

**Preface**

**Acknowledgments**

**Chapter 1**

**The Evolution of Aircraft Class and Squadron Designation Systems**

**Chapter 2**

**Attack Squadron Histories (VA) VA-1E to VA-873**

**Chapter 3**

**Heavy Attack Squadron Histories (VAH) VAH-8 to VAH-123**

**Chapter 4**

**Tactical Aerial Refueling Squadron Histories (VAK) VAK-208 to VAK-308**

**Chapter 5**

**Light Attack Squadron History (VAL) VAL-4**

**Chapter 6**

**Heavy Photographic Squadron Histories (VAP) VAP-61 to VAP-62**

**Chapter 7**

**Strike Fighter Squadron Histories (VFA) VAF-15 to VFA-305**

Page down to continue

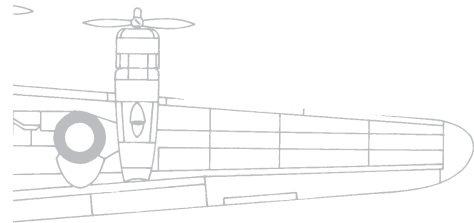

- Appendix 1** Aircraft Data—Technical Information and Drawings
- Appendix 2** Aircraft Carrier Listing for CV, CVB, CVA, CVAN, CVN, CVL, and CVE Designations
- Appendix 3** Carrier Deployments by Year
- Appendix 4** U.S. Navy Squadron Designations and Abbreviations
- Appendix 5** How to Trace Squadron Lineage
- Appendix 6** Lineage Listing for VAS, VA(AW), VAH, VA(HM), VAK, VAL, VAP, and VFA Designated Squadrons
- Appendix 7** Types of Aircraft Listed in Squadron Histories
- Glossary Of Abbreviations and Terms
- Bibliography
- Index of Squadron Histories and Aircraft Data

Page down to continue



## ***Welcome to Naval Aviation History***

Welcome to the Naval Aviation History Office and its publication *Dictionary of American Naval Aviation Squadrons Volume 1 The History of VA, VAH, VAK, VAL, VAP and VFA Squadrons*. Information on the development of this book may be found in its Foreword, Preface and Acknowledgments sections. This series will continue to cover all the squadron communities and designations in Naval Aviation.

To fully understand the purpose of this book, the reader should know the background of the Naval Aviation History Office and its mission. The office was established in January 1942 with the missions of documenting Naval Aviation's involvement in World War II; collecting records; writing the history of Naval Aviation; and providing advice and research assistance on Naval Aviation to the Bureau of Aeronautics and Deputy Chief of Naval Operations (Air). These functions have changed very little since the office's inception. Today's primary functions include writing and publishing articles, monographs and books on Naval Aviation; collecting, processing, indexing, preserving and maintaining official documents relevant to the history of Naval Aviation; and providing advice and research assistance on Naval Aviation history to the Director, Air Warfare, an office of the Chief of Naval Operations; the Director, Naval Historical Center; active duty Naval Aviation Commands; and other individuals or organizations that have an interest in Naval Aviation.

The Naval Aviation History Office became a branch of the Naval Historical Center in 1986. It deals primarily with the operational aspects of Naval Aviation, and the bulk of its records cover those activities. Technical developments are handled by the Naval Air Systems Command. The majority of the records currently in the office cover the operational activities of Naval Aviation Commands from 1957 to present. These comprise annual history reports submitted by all the aviation commands, and aviation records from the Chief of Naval Operations. The office has a limited amount of data and records dealing with the early period of Naval Aviation from its inception in 1911 to 1957. Records prior to 1953 are held by the Naval Historical Center's Operational Archives Branch or the National Archives.

Page down to continue

**There are several specific aviation record collections maintained by the office that are important reference works pertinent to the study of Naval Aviation. These reference collections include:**

**Naval Aviation Insignia, World War II to present.**

**Aircraft History Cards, a record of assignment by bureau number, for every aircraft in the Navy's inventory up to 1987. This collection is on microfilm.**

**Aircraft Accident Summaries, a summary report on naval aircraft accidents, filed by aircraft type and date of accident. This collection is on microfilm and covers the period 1920 to June 1955.**

***Naval Aviation News* magazine and its forerunners, 1917 to present.**

**Naval Aeronautical Organization publication, Fiscal Year 1923 to present.**

**Monthly Report, Status of Naval Aircraft publication, 1926 to 1954.**

**Allowances and Location of Navy Aircraft publication, 1949 to 1988.**

**Naval Aviation Summary publication, 1949 to present.**

**The office has been active in writing the history of Naval Aviation. Its first major writing project was part of the United States Naval Administrative Histories of World War II. In that collection, the history of the Office of Deputy Chief of Naval Operations (Air) covers 20 volumes dealing with Naval Aviation from 1911 through World War II. Besides the Administrative Histories series, the office has published, and updated every decade, a major reference work on the history of Naval Aviation entitled *United States Naval Aviation 1910–1980*. It is a chronology of significant events in Naval Aviation with an extensive appendices covering a wide range of special projects and data. This book is being updated and is scheduled to be published as *United States Naval Aviation 1910–1995*. Other works published by the office are as follows:**

***Naval Aviation in World War I*, a monograph.**

***U.S. Naval Aviation in the Pacific*, a monograph.**

***Kite Balloons to Airships . . . the Navy's Lighter-than-Air Experience*, a monograph.**

**The annual "Naval Aviation in Review" article published in *Naval Aviation News* magazine.**

**The Naval Aviation History Office is open to the public. Researchers are welcome to visit the office Monday through Wednesday and Friday from 9:00 a.m. to 4:00 p.m. The office is closed on Thursdays and all Federal Holidays. It is located in Building 157 on the historic Washington Navy Yard in Washington, D.C.**

**Page down to continue**

# About this CD-ROM . . .

With this CD-ROM, you can

*View and print any part of any document*  
*Search for words and phrases*

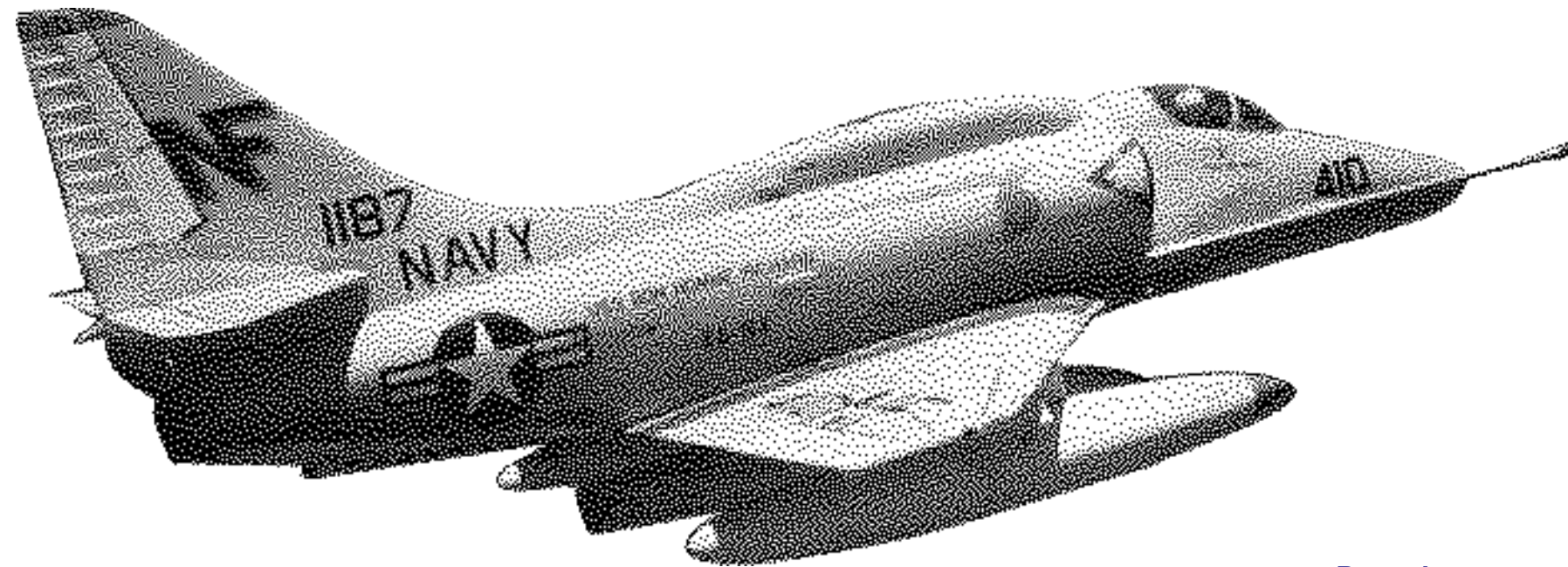

Page down to continue

**View and print documents.** The software on this CD-ROM will help you view any part of any document on your computer screen or print any part of any document with an appearance very close to the published document.

**Search for words or phrases.** The software will help you search one document, several documents, or all documents for words or phrases you want to find. Because the documents are fully indexed, most searches will take only a few seconds.

**Export text to your clipboard.** The software on this CD-ROM will let you mark a section of text in any document and copy it to your clipboard or other software that manipulates text.

**We welcome your comments** regarding this CD-ROM  
or the electronic dissemination of Dictionary of American Naval  
Aviation Squadrons.

*Contact us by writing to:*

**Naval Historical Center  
Naval Aviation History Branch  
Washington Navy Yard  
901 M Street, SE  
Washington, DC 20374-5060**